

ELECTRIC CLAMPING

02/28/2025



info@cesehsa.com.mx

cesehsa.com.mx

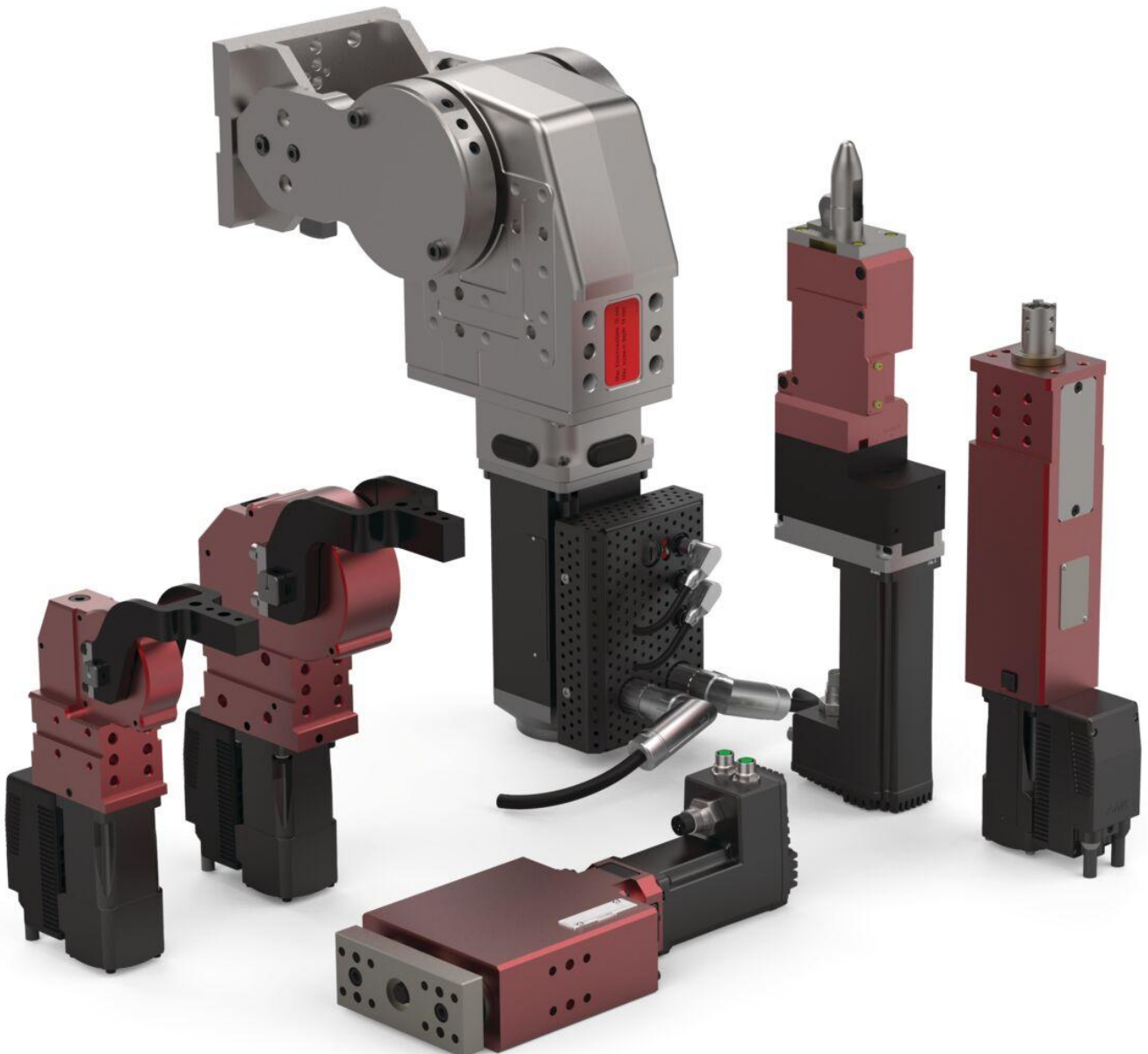

DESTACO Custom Catalog

02/28/2025

This catalog is a custom document and the products included is based on your unique selection from portions of complete catalogs that already exist. Please refer to our full catalogs for more information on products not included in this customized document.

Table of Contents

Electric Products

PC-ELC-1

DESTACO Custom Catalog

02/28/2025

Table of Contents (continued)

92W-1

Enclosed Electric Power Clamps | Smart Clamp | How to Order

92W-1 23 00 02 02

Clamp Arm Shaft	Shaft Length (L)
03	10 mm [0.39 in]
23	16 mm [0.63 in]

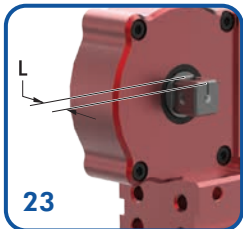
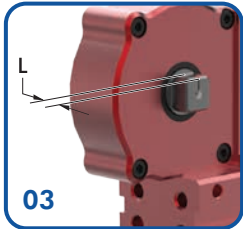

Body Style
 for 400 V Motor Option 01 only
 01 Compact Clamp Design
 for 48 V Motor Option 02 only
 02 Compact Clamp Design

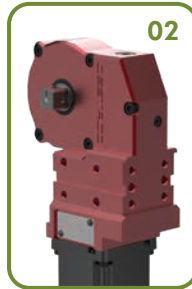

Motor
 for Body Style Option 01 only
 01 Servo Drive, Decentral 400 V
 for Body Style Option 02 only
 02 Servo Drive, Decentral 48 V

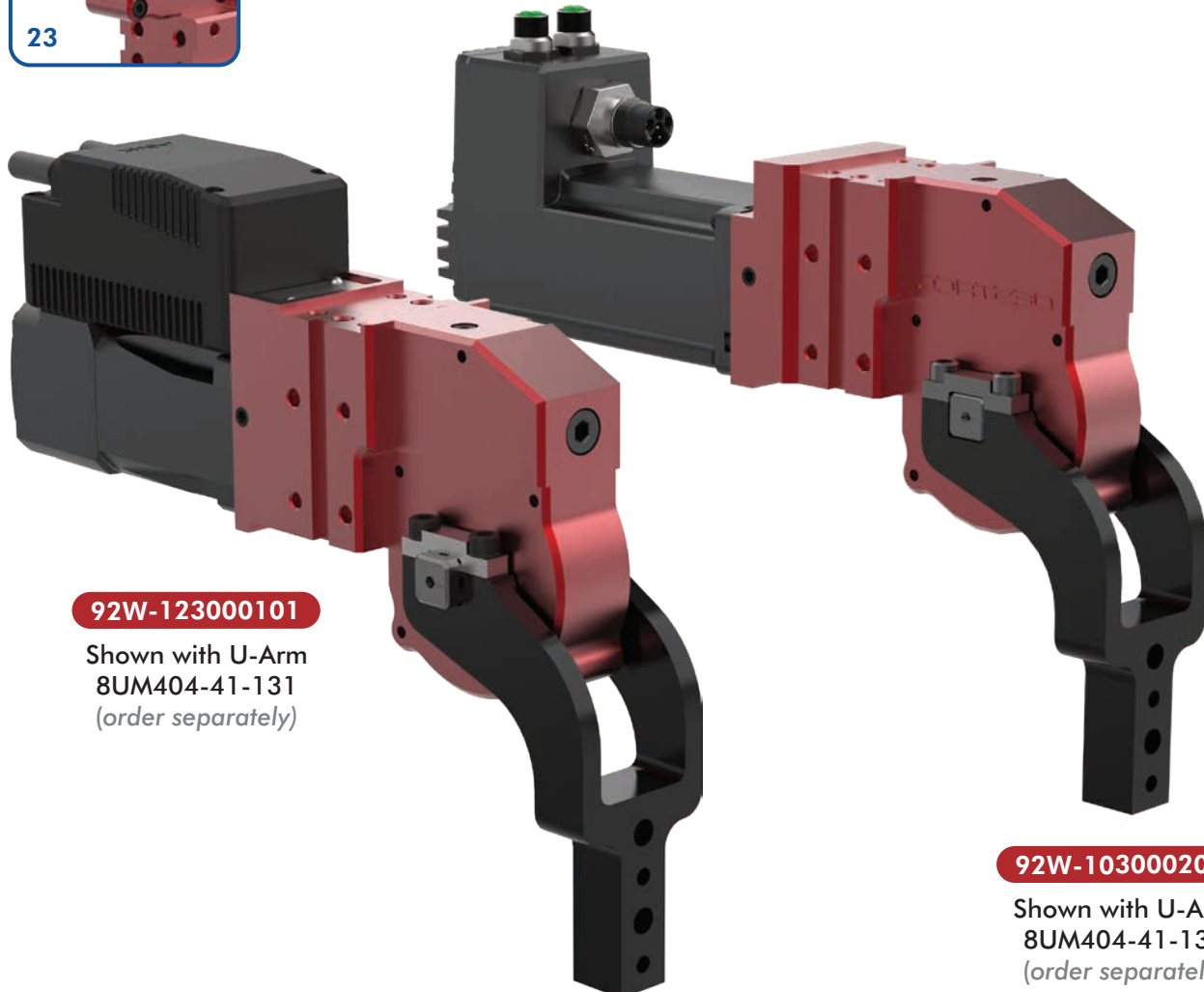

92W-123000101
 Shown with U-Arm
 8UM404-41-131
 (order separately)

92W-103000202
 Shown with U-Arm
 8UM404-41-131
 (order separately)

92W-1....0202

Enclosed Electric Power Clamps | Smart Clamp | Dimensions | Technical Specifications

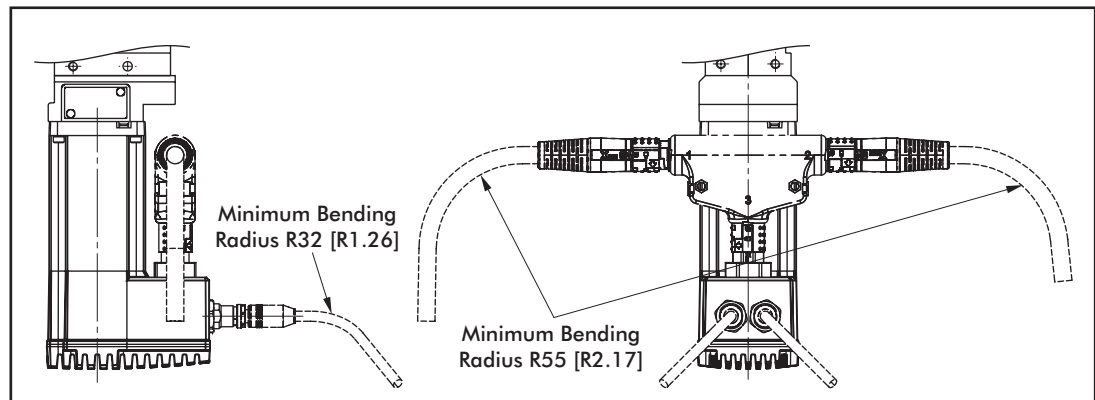
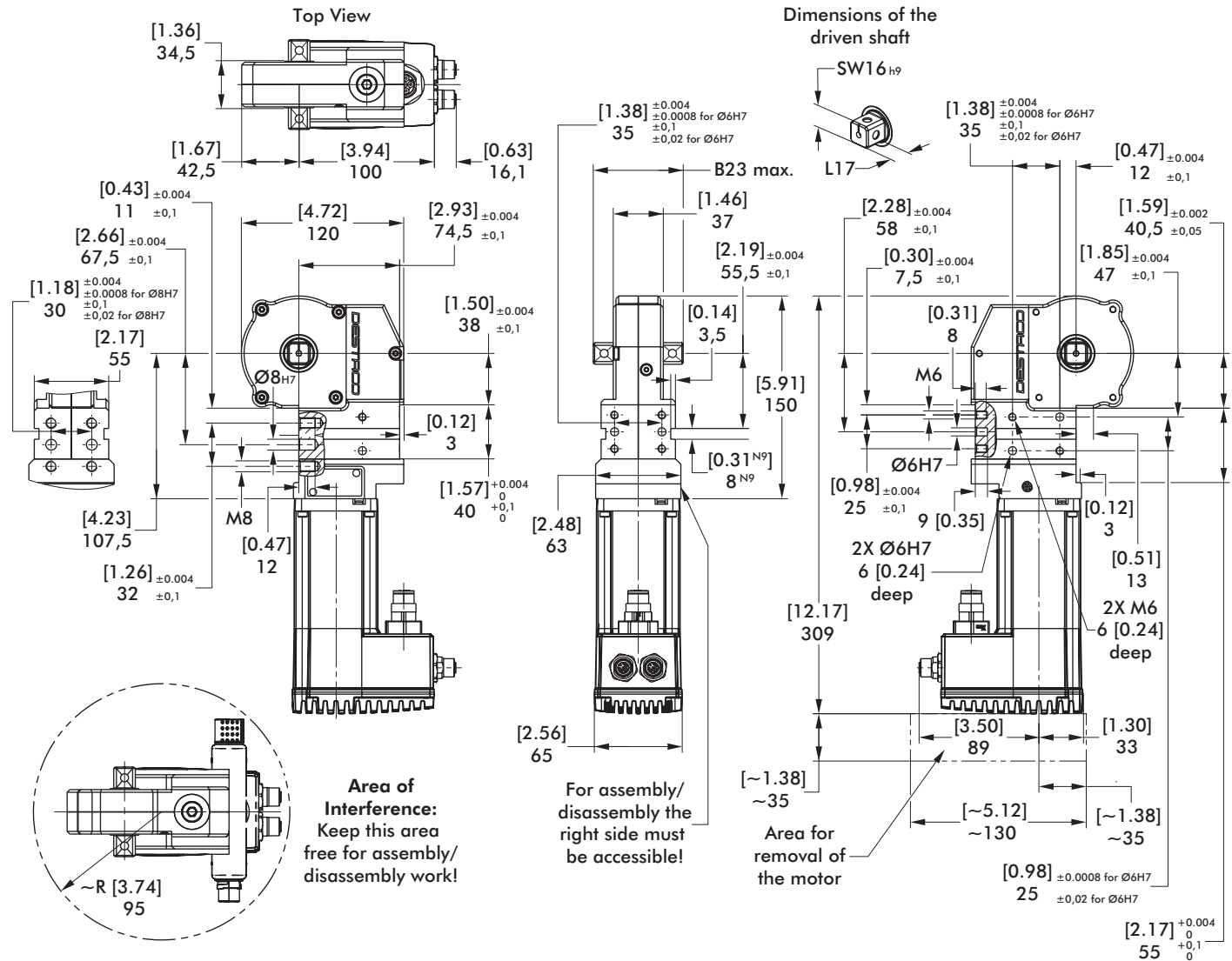

Model	Max. Holding Torque Nm [ft-lb]	Max. Clamping Torque Nm [ft-lb]	Weight kg [lbs]	B23 Max.	L17
92W-103000202	[332] 450	[7.4-89] 10-120	[7.93] 3,6	54,5 [2.15]	10 [0.39]
92W-123000202				66,5 [2.62]	16 [0.63]

Part Present Control and Tolerance Compensation

Distance (L) [in] mm	Part Thickness (X) Min. Tolerance (Tmin)* [in] mm	Tolerance Range [in] mm
[3.94 ±0.004] 100 ±0,1	[±0.0098] ±0,25	[0.019] 0,5
[5.91 ±0.004] 150 ±0,1	[±0.0138] ±0,35	[0.027] 0,7
[7.87 ±0.004] Max. 200 ±0,1 Max.	[±0.0177] ±0,45	[0.031] 0,9

*Specification only as a guideline

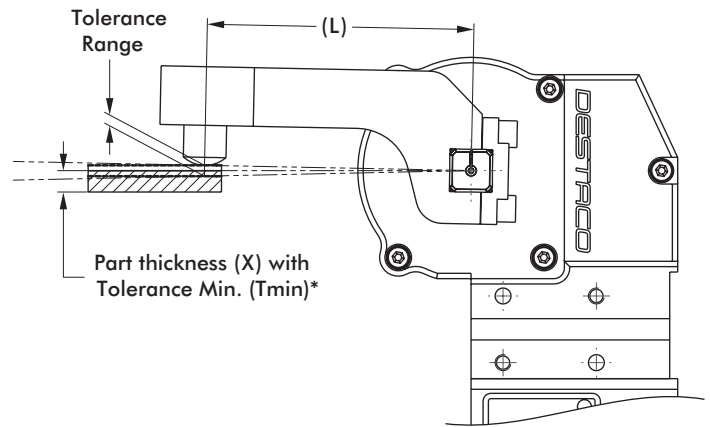

Technical Specifications

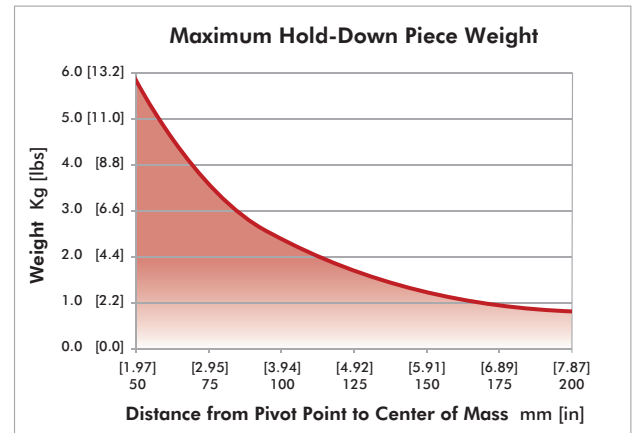
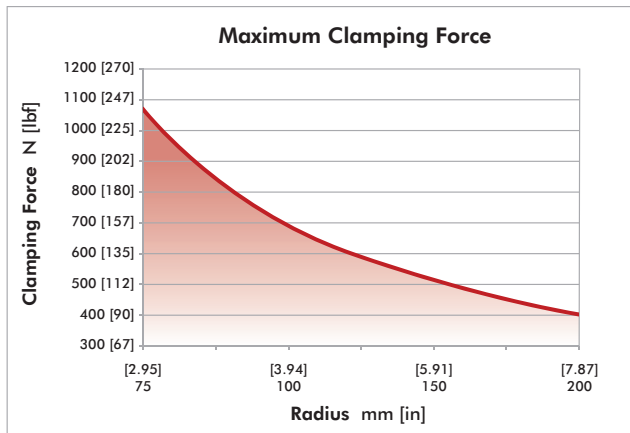

92W-1 U-ARMS CENTER (ALUMINUM)

Enclosed Electric Power Clamps | Dimensions | Technical Specifications

U-Clamp Arm, Center

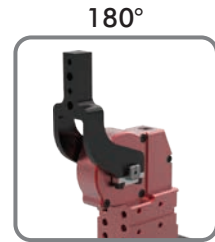
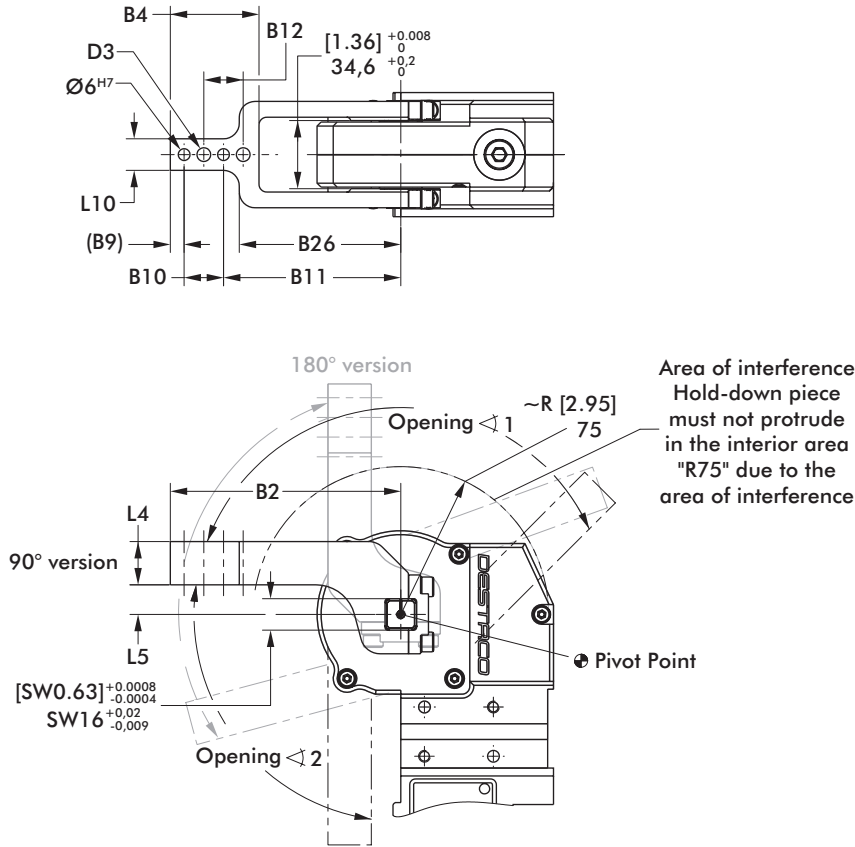

- 8UM404-00-117
- 8UM404E-15-117
- 8UM404E-15-144
- 8UM404E-25-117
- 8UM404E-45-107
- 8UM404-41-131

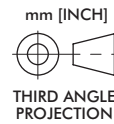

Arm Model No.	Max. Opening Angle for 90° Version		Max. Opening Angle for 180° Version		Weight kg [lbs]	B2	B4	B9	B10	B11	B12	B26	D3	L4	L5	L10
	∠ 1	∠ 2	∠ 1	∠ 2		[±0.0008] ±0,02	[±0.004] ±0,1	[±0.008] ±0,2	[±0.008] ±0,2	[±0.008] ±0,2	[±0.008] ±0,2	[±0.008] ±0,2	[±0.008] ±0,2	[±0.008] ±0,2	[±0.004] ±0,1	[±0.004] ±0,1
8UM404-00-117	135°	85°	55°	140°	[0.49] 0,22	[4.61] 117	[1.77] 45	[0.28] 7	[0.79] 20	[3.54] 90	[0.79] 20		[0.28] 7	[0.87] 22	0	[0.63] 16
8UM404E-15-117		70°	105°	[0.51] 0,23	[5.67] 144	[2.83] 72	[0.35] 9	[1.18] 30	[4.13] 105	[1.18] 30	[3.23] 82	[0.35] 9	[1.10] 28	[0.59] 15	[0.79] 20	
8UM404E-15-144		90°	90°	100°	[0.73] 0,33	[4.61] 117	[1.77] 45	[0.28] 7	[0.79] 20	[3.54] 90	[0.79] 20		[0.28] 7	[0.87] 22	[0.98] 25	[0.63] 16
8UM404E-25-117		110°	95°	[0.53] 0,24	[4.21] 107	[1.77] 45	[0.28] 7	[0.79] 20	[3.15] 80	[0.79] 20	[2.83] 72	[0.28] 7	[0.87] 22	[1.77] 45	[0.63] 16	
8UM404E-45-107		105°	95°	[0.64] 0,29	[5.16] 131	[2.64] 67	[0.35] 9	[1.18] 30	[3.62] 92	[1.18] 30	[3.03] 77	[0.35] 9		[1.61] 41	[0.79] 20	
8UM404-41-131		135°	105°	95°	[0.64] 0,29	[5.16] 131	[2.64] 67	[0.35] 9	[1.18] 30	[3.62] 92	[1.18] 30	[3.03] 77	[0.35] 9		[1.61] 41	[0.79] 20

Dimensions = [in] mm

92W-1 U-ARMS OFFSET (ALUMINUM)

Enclosed Electric Power Clamps | Dimensions | Technical Specifications

U-Clamp Arm, Offset

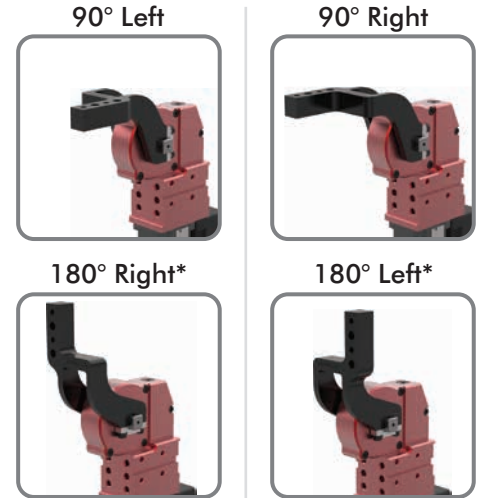
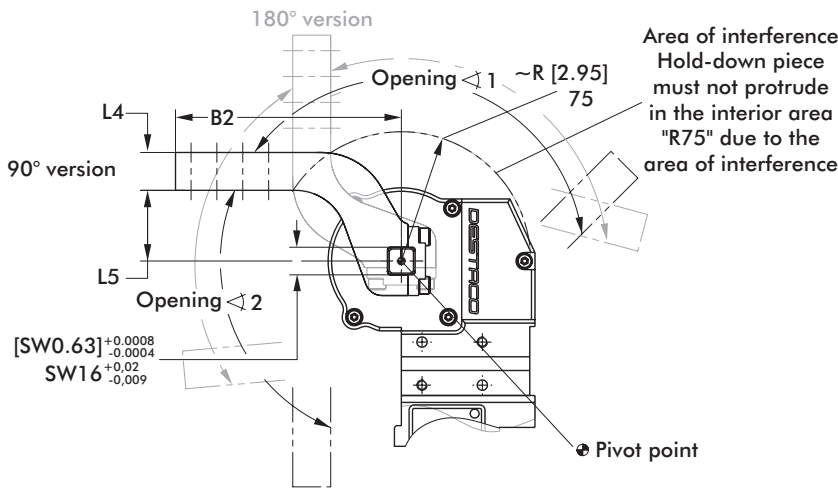
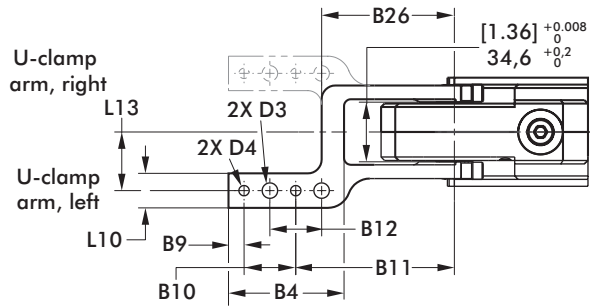

- 8UL404-00-117
 - 8UL404E-15-117
 - 8UL404E-25-117
 - 8UL404E-45-107
 - 8UL404E-15-144
 - 8UL404-41-131
- 8UR404-00-117
 - 8UR404E-15-117
 - 8UR404E-25-117
 - 8UR404E-45-107
 - 8UR404E-15-144
 - 8UR404-41-131

*90° left/180° right uses same clamp arm.
90° right/180° left uses same clamp arm.

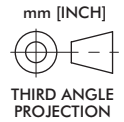

Arm Model No. Left 90° / Right 180°	Arm Model No. Right 90° / Left 180°	Max. Opening Angle for 90° Version		Max. Opening Angle for 180° Version		Weight kg [lbs]
		$\sphericalangle 1$	$\sphericalangle 2$	$\sphericalangle 1$	$\sphericalangle 2$	
8UL404-00-117	8UR404-00-117	135°	85°	55°	140°	0,22 [0.49]
8UL404E-15-117	8UR404E-15-117		70°	105°	0,23 [0.51]	
8UL404E-25-117	8UR404E-25-117		90°	100°	0,24 [0.53]	
8UL404E-45-107	8UR404E-45-107		70°	105°	0,35 [0.77]	
8UL404E-15-144	8UR404E-15-144		105°	95°	0,30 [0.66]	
8UL404-41-131	8UR404-41-131		105°	95°		

Arm Model No. Left 90° / Right 180°	Arm Model No. Right 90° / Left 180°	B2	B4	B9	B10	B11	B12	B26	L4	L5	\varnothing D3	\varnothing D4	L10	L13
					[±0.0008] ±0,02	[±0.004] ±0,1	[±0.008] ±0,2		[±0.004] ±0,1			H7		[±0.004] ±0,1
8UL404-00-117	8UR404-00-117									0				
8UL404E-15-117	8UR404E-15-117	[4.61] 117	[1.77] 45	[0.28] 7	[0.79] 20	[3.54] 90	[0.79] 20	[3.23] 82	[0.87] 22	[0.59] 15	[0.28] 7		[0.63] 16	[0.91] 23
8UL404E-25-117	8UR404E-25-117									[0.98] 25				
8UL404E-45-107	8UR404E-45-107	[4.21] 107				[3.15] 80		[2.83] 72		[1.77] 45	[0.24] 6			
8UL404E-15-144	8UR404E-15-144	[5.67] 144	[2.83] 72		[1.18] 30	[4.13] 105	[1.18] 30	[3.23] 82	[1.10] 28	[0.59] 15			[0.79] 20	[1.46] 37
8UL404-41-131	8UR404-41-131	[5.16] 131	[2.64] 67	[0.35] 9		[3.62] 92		[3.03] 77	[0.87] 22	[1.61] 41				[1.34] 34

Dimensions = [in] mm

92W-1 H-ARMS (ALUMINUM)

Enclosed Electric Power Clamps | Dimensions | Technical Specifications

H-Clamp Arms

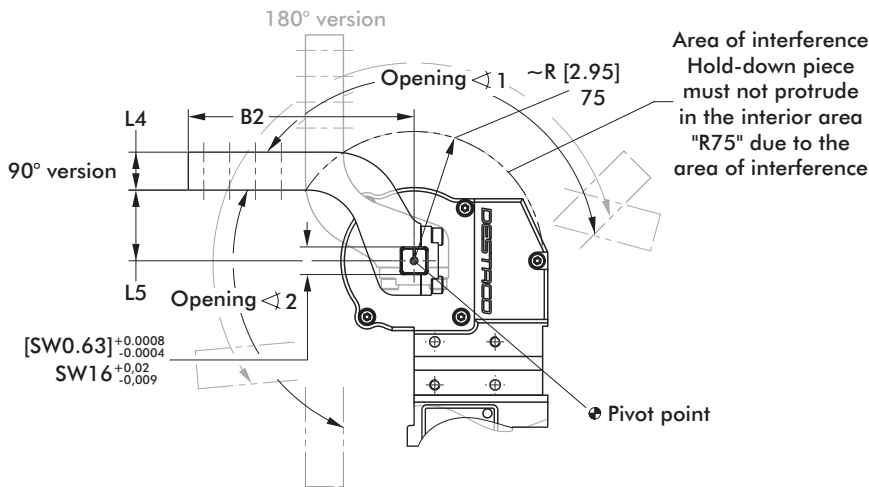
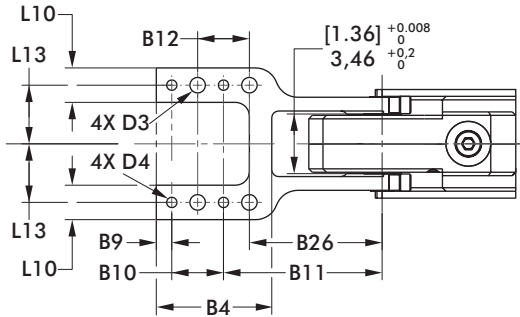

8UH404E-15-117
8UH404E-15-144
8UH404-41-131

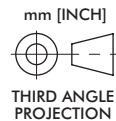

Arm Model No.	Max. Opening Angle for 90° Version		Max. Opening Angle for 180° Version		Weight kg [lbs]
	$\sphericalangle 1$	$\sphericalangle 2$	$\sphericalangle 1$	$\sphericalangle 2$	
8UH404E-15-117			70°	105°	[0.57] 0,26
8UH404E-15-144	135°	90°			[1.01] 0,46
8UH404-41-131			105°	95°	[0.82] 0,37

Arm Model No.	B2	B4	B9	B10 ± 0.0008 ± 0.02	B11 ± 0.004 $\pm 0,1$	B12 ± 0.008 $\pm 0,2$	B26	L4 ± 0.004 $\pm 0,1$	L5	D3	D4 H7	L10	L13 ± 0.004 $\pm 0,1$
8UH404E-15-117	[4.61] 117	[1.77] 45	[0.28] 7	[0.79] 20	[3.54] 90	[0.79] 20	[3.23] 82	[0.87] 22	[0.59] 15	[0.28] 7		[0.63] 16	[0.91] 23
8UH404E-15-144	[5.67] 144	[2.83] 72	[0.35] 9	[1.18] 30	[4.13] 105	[1.18] 30		[1.10] 28		[0.35] 9	[0.24] 6	[0.79] 20	[1.46] 37
8UH404-41-131	[5.16] 131	[2.64] 67			[3.62] 92		[3.03] 77	[0.87] 22	[1.61] 41				[1.34] 34

Dimensions = [in] mm



95W-1

Electric Smart Guides/Lifters | How to Order

95W-1 01 02 10 60

Motor Connection	Description
00	Straight, without Drive
01	Straight, Rear Connections
02	Straight, Connections on Right
03	Straight, Connections on Left
10	Redirected, without Drive
11	Redirected, Rear Connections
12	Redirected, Connections on Right
13	Redirected, Connections on Left

Motor	Description
01	Servo Drive, Decentral 400 V
02	Servo Drive, Decentral 48 V

Stroke	Description
60	0-60 mm Stroke, Standard

Mounting Plate	Description
10	Mounting Plate, Standard

95W-111021060

95W-101011060



95W-10.011060

Electric Smart Guides/Lifters | Dimensions | Technical Specifications

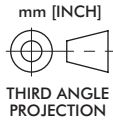

mm [INCH]
Max. Stroke
= 60 [2.36]

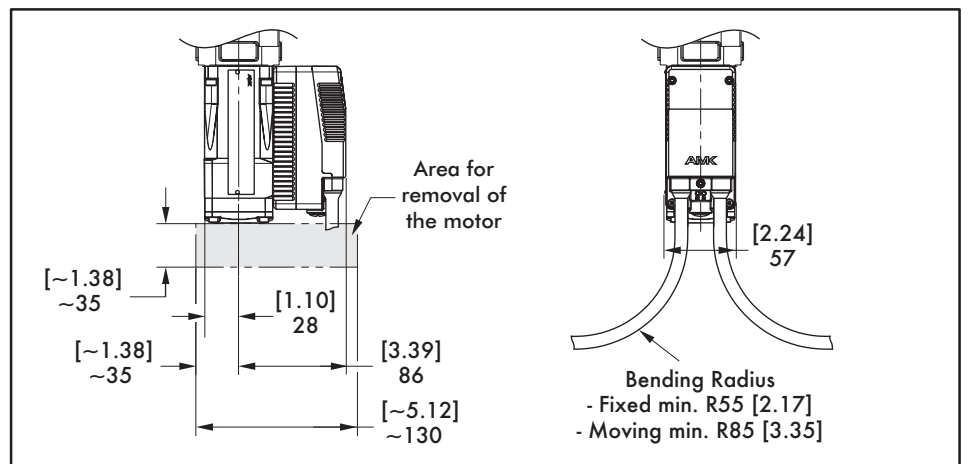
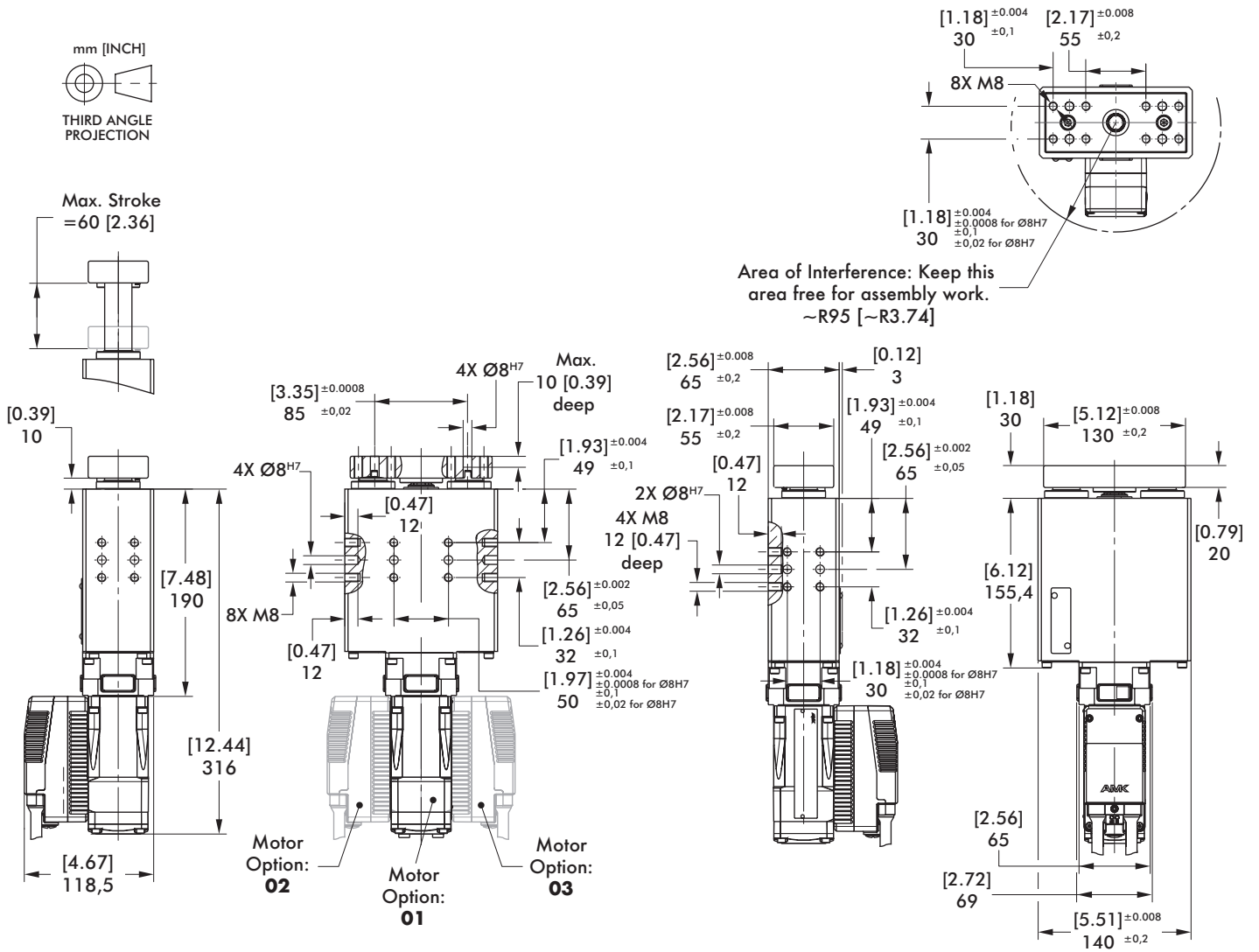

Base Model	Stroke mm [in]	Lifting Force N [lbf]	Holding Force N [lbf]	Speed Max. mm/s [in/s]	Weight Kg [lbs]
95W-10.011060	[0-2.36] 0-60	[225] 1000	[225] 1000	[2.36] 60	[16.31] 7,4

95W-10.021060

Electric Smart Guides/Lifters | Dimensions | Technical Specifications

mm [INCH]

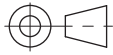

THIRD ANGLE PROJECTION

Max. Stroke
=60 [2.36]

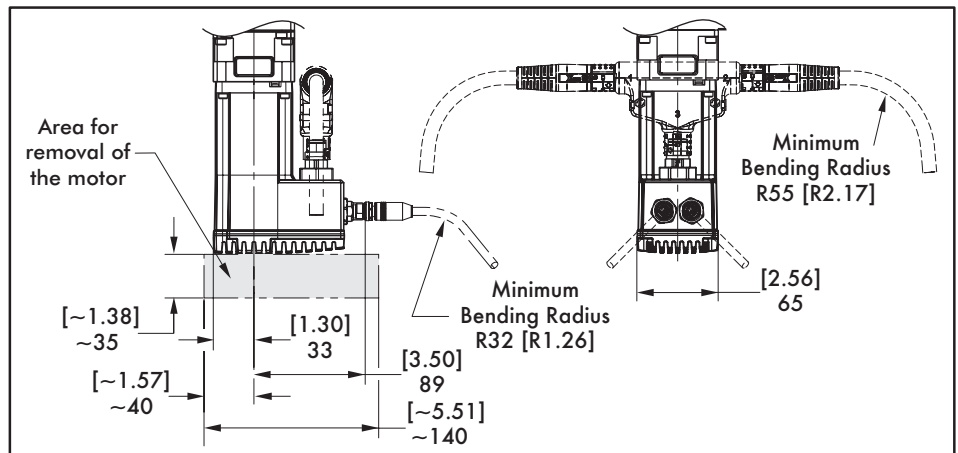
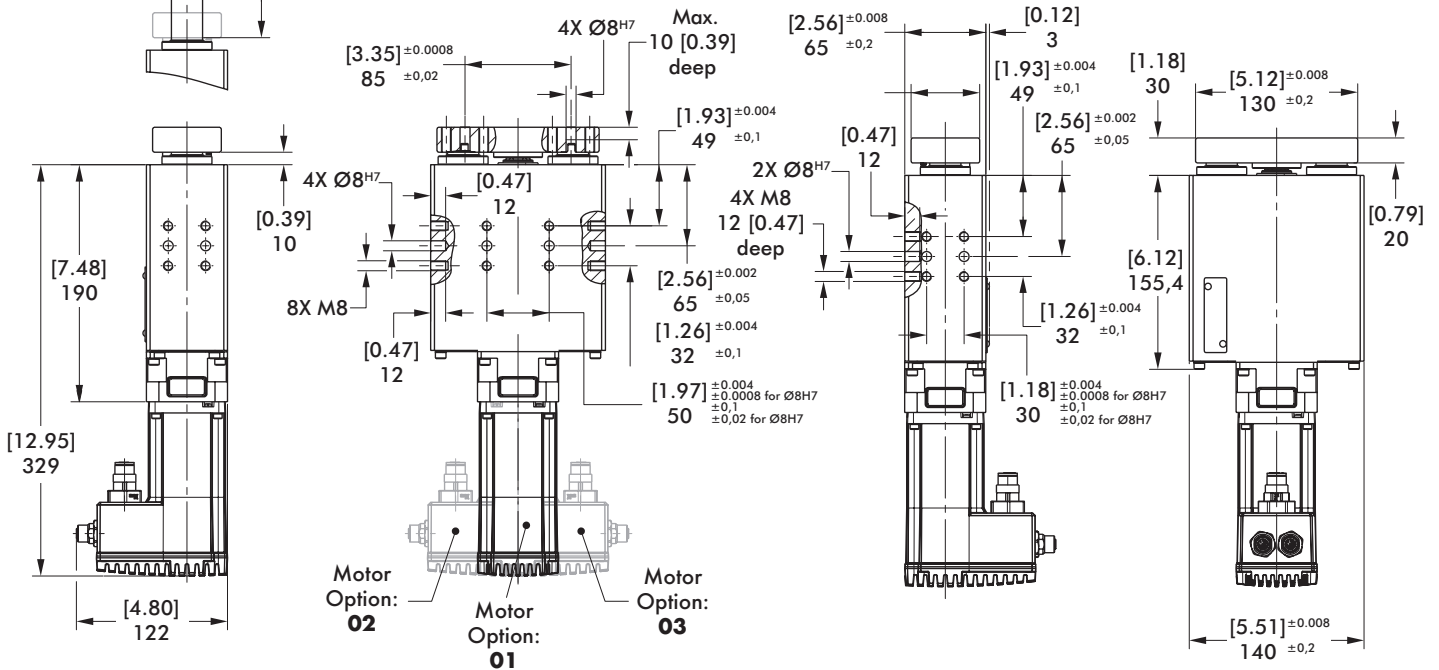
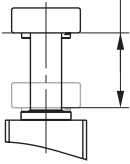

Base Model	Stroke mm [in]	Lifting Force N [lbf]	Holding Force N [lbf]	Speed Max. mm/s [in/s]	Weight Kg [lbs]
95W-10.021060	[0-2.36] 0-60	[225] 1000	[225] 1000	[2.36] 60	[16.09] 7,3

95W-11.021060

Electric Smart Guides/Lifters | Dimensions | Technical Specifications

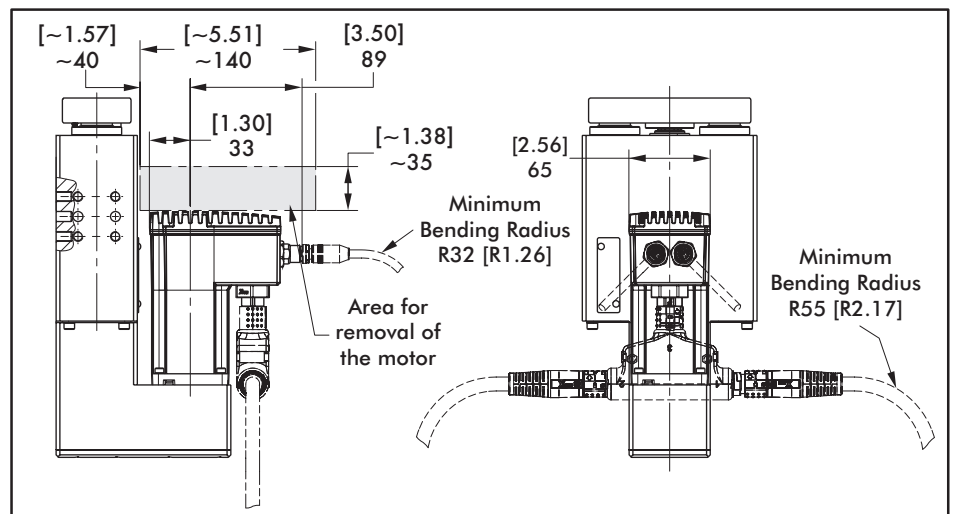
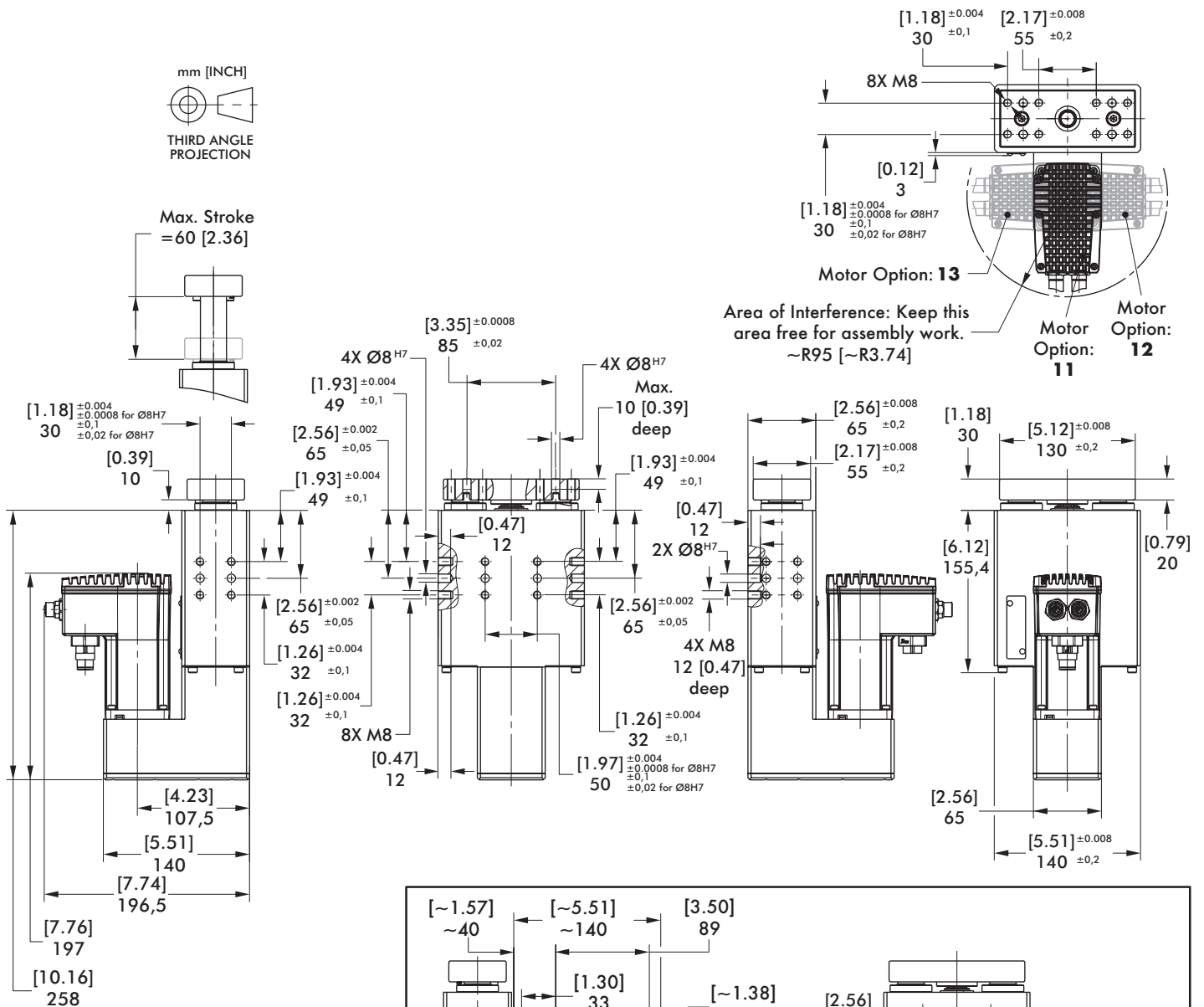
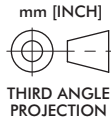

Base Model	Stroke mm [in]	Lifting Force N [lbf]	Holding Force N [lbf]	Speed Max. mm/s [in/s]	Weight Kg [lbs]
95W-11.021060	[0-2.36] 0-60	[225] 1000	[225] 1000	[2.36] 60	[19.62] 8,9

95W-11.011060

Electric Smart Guides/Lifters | Dimensions | Technical Specifications

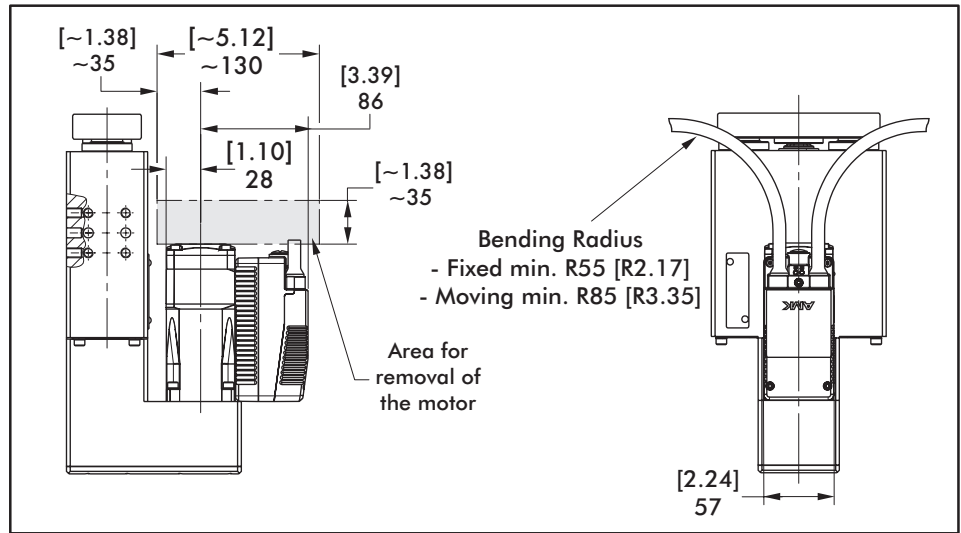
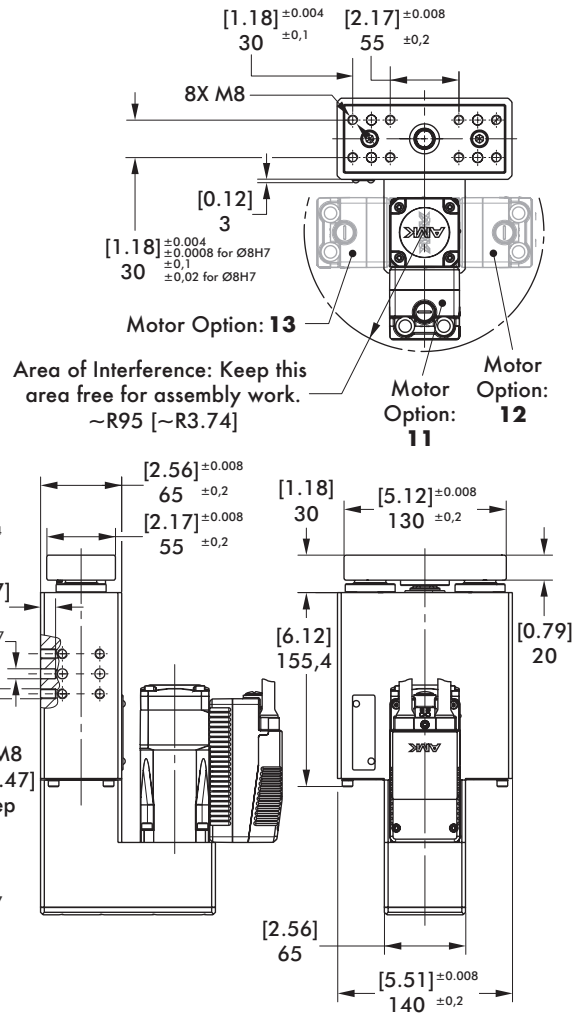
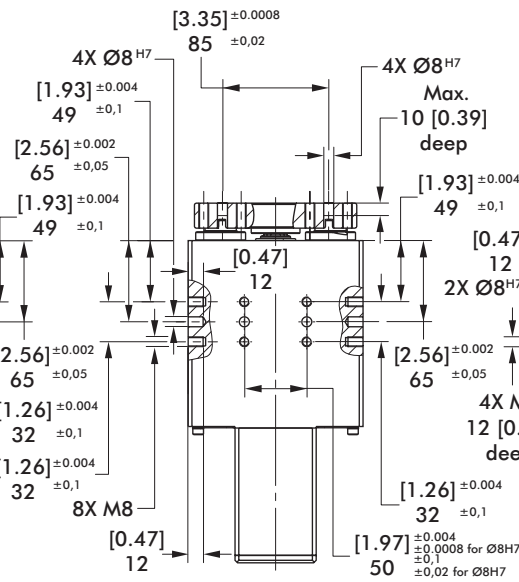
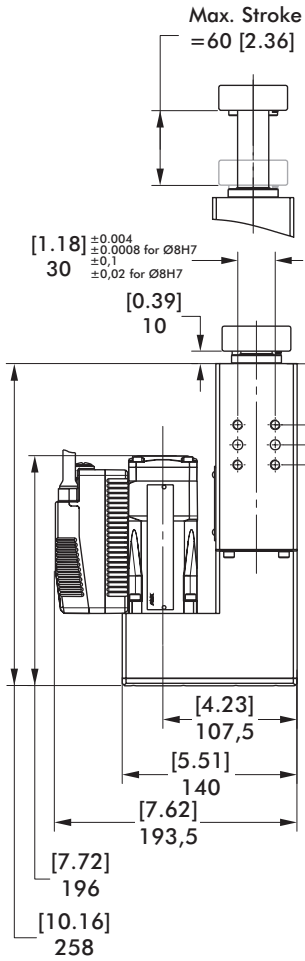
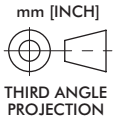

Base Model	Stroke mm [in]	Lifting Force N [lbf]	Holding Force N [lbf]	Speed Max. mm/s [in/s]	Weight Kg [lbs]
95W-11.011060	[0-2.36] 0-60	[225] 1000	[225] 1000	[2.36] 60	[20.72] 9,4



96W-1

Electric Pin Package | Smart Pin Package | How to Order

96W-1 01 02 A4 60

Stroke	Description
40*	0-40 mm Stroke
60	0-60 mm Stroke

*Straight motor option only.

Motor Connection	Description
00	Straight, without Drive
01	Straight, Rear Connections
02	Straight, Connections on Right
03	Straight, Connections on Left
10	Redirected, without Drive
11	Redirected, Rear Connections
12	Redirected, Connections on Right
13	Redirected, Connections on Left

Motor	Description
01	Servo Drive, Decentral 400 V
02	Servo Drive, Decentral 48 V

Piston Rod	Description
02*	Ø16 mm Cross Groove (*with M6 Threaded Inside Hole for Redirected Motor Connections 10, 11, 12, 13 see page 20)
04	NAAMS Standard
A4	NAAMS Standard Rotated 180°
B4	NAAMS Standard Rotated 90°
C4	NAAMS Standard Rotated 270°
05	Ø10 mm Inside Hole, Cross Groove

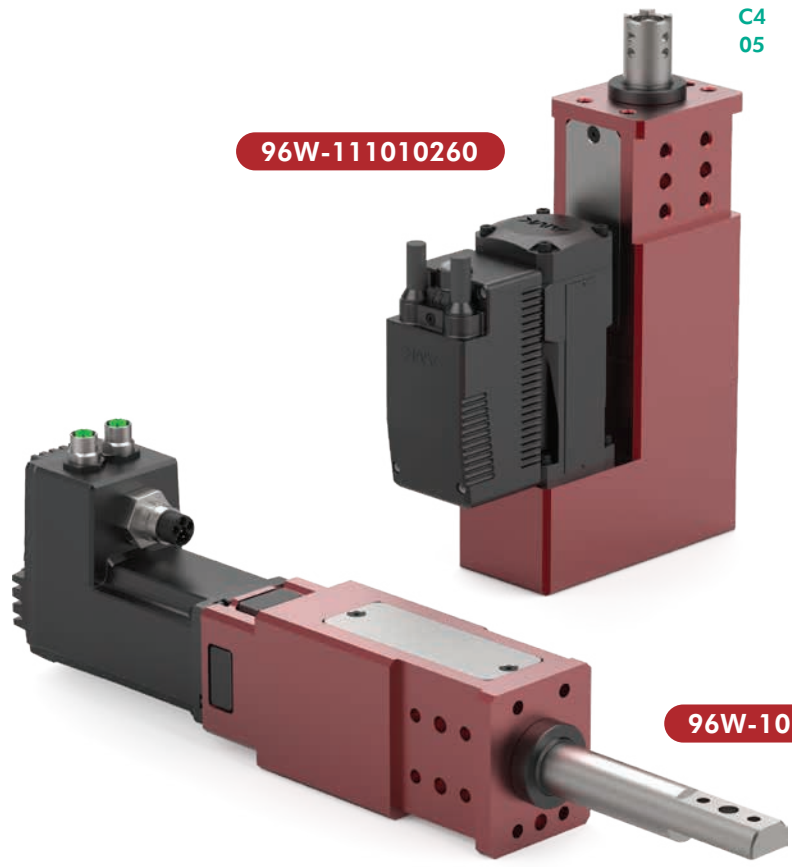

Electric Pin Package | Smart Pin Package | Dimensions | Technical Specifications

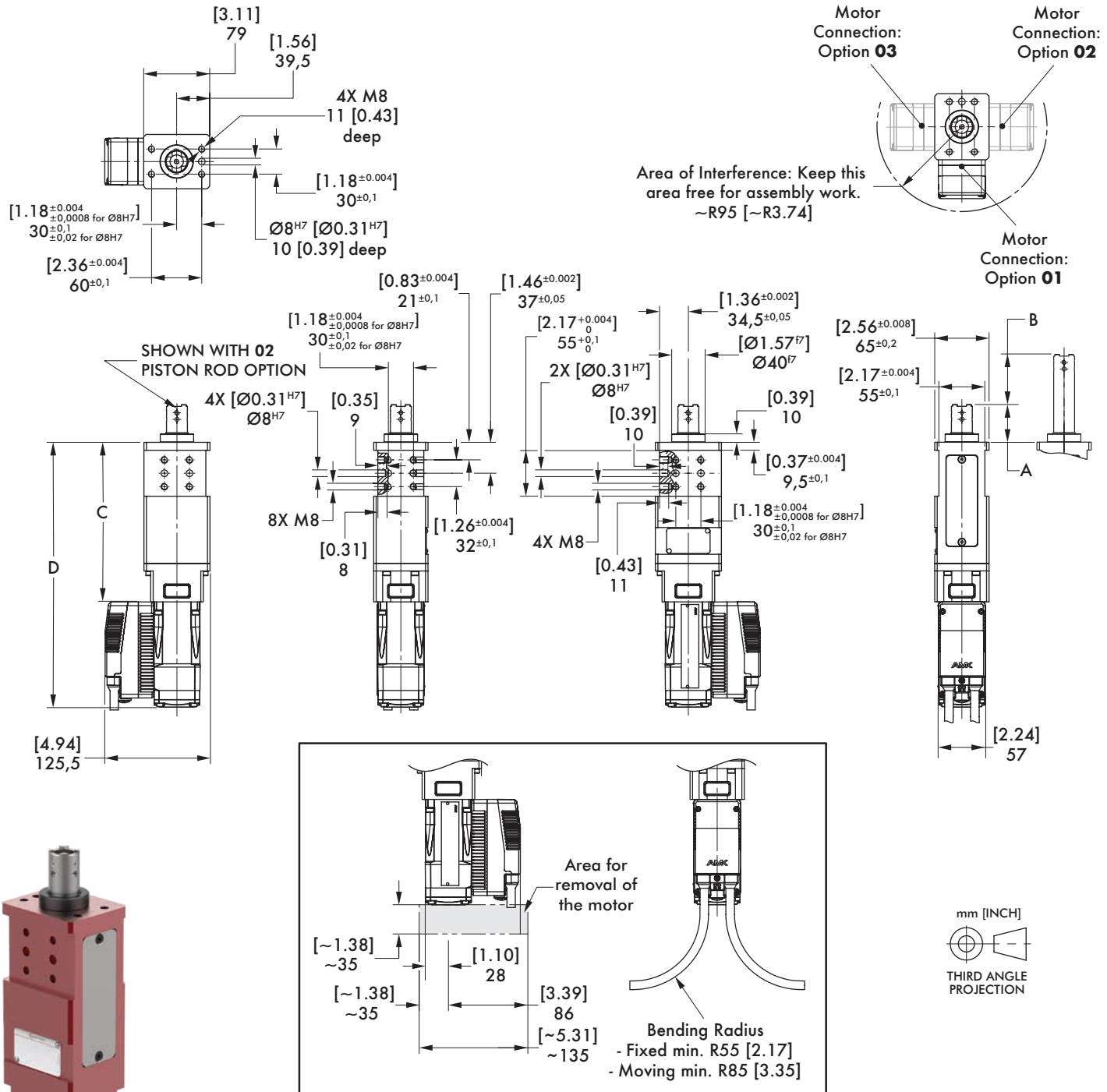

Base Model	Stroke B mm [in]	Thrust Force N [lbf]	Retraction Force N [lbf]	Speed Max. mm/s [in/s]	Weight Kg [lbs]	A mm [in]	C mm [in]	D mm [in]
96W-10.010240 96W-10.010540	[0-1.57] 0-40	[225] 1000	[225] 1000	[2.36] 60	[9.48] 4,3	[1.77] 45	[6.73] 171	[11.69] 297
96W-10.01.440						[2.76] 70		
96W-10.010260 96W-10.010560	[0-2.36] 0-60	[225] 1000	[225] 1000	[2.36] 60	[10.14] 4,6	[1.77] 45	[7.52] 191	[12.48] 317
96W-10.01.460						[2.76] 70		

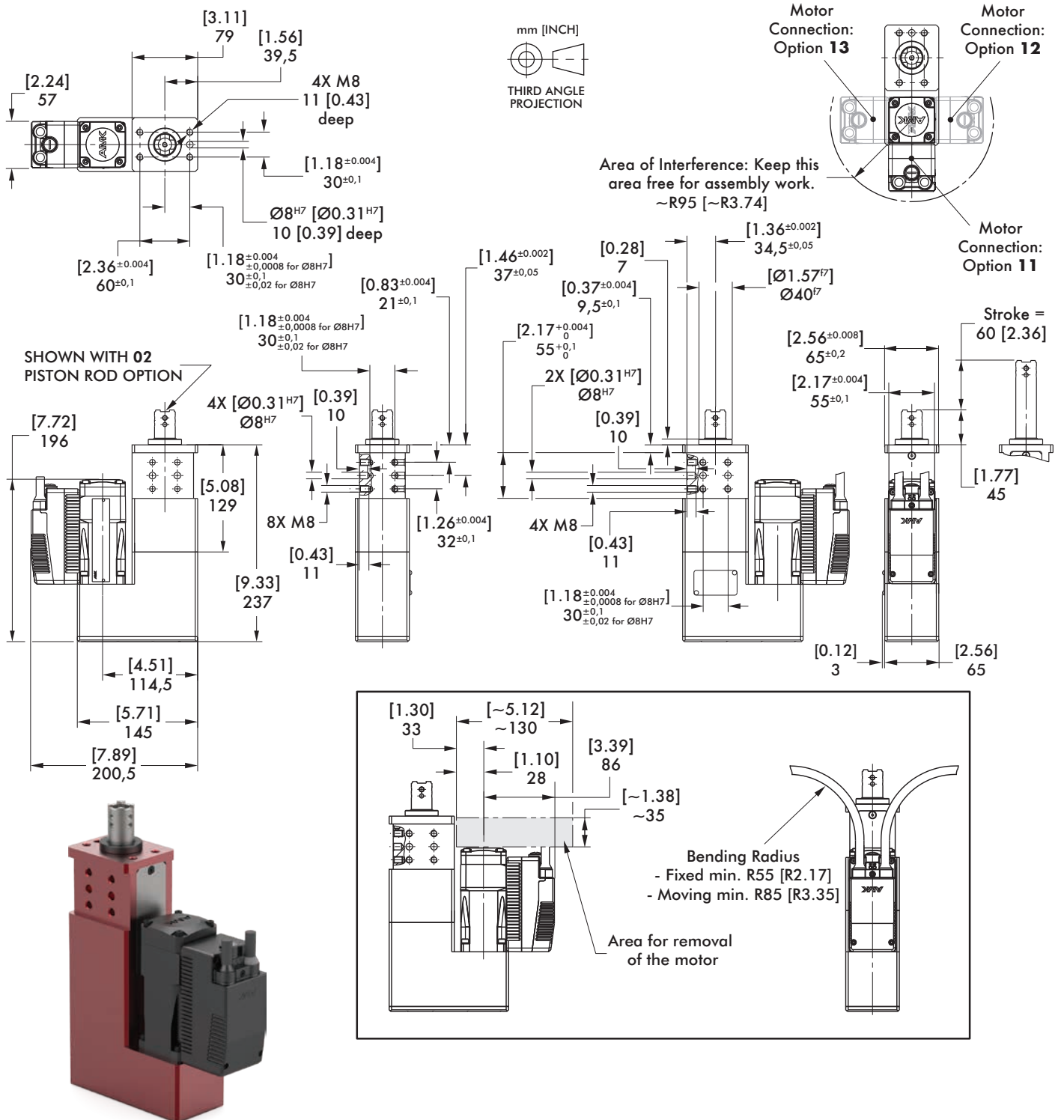

Base Model	Stroke mm [in]	Thrust Force N [lbf]	Retraction Force N [lbf]	Speed Max. mm/s [in/s]	Weight Kg [lbs]
96W-11.01..60	[0-2.36] 0-60	[225] 1000	[225] 1000	[2.36] 60	[14,33] 6,5

96W-11.02..60

Electric Pin Package | Smart Pin Package | Dimensions | Technical Specifications

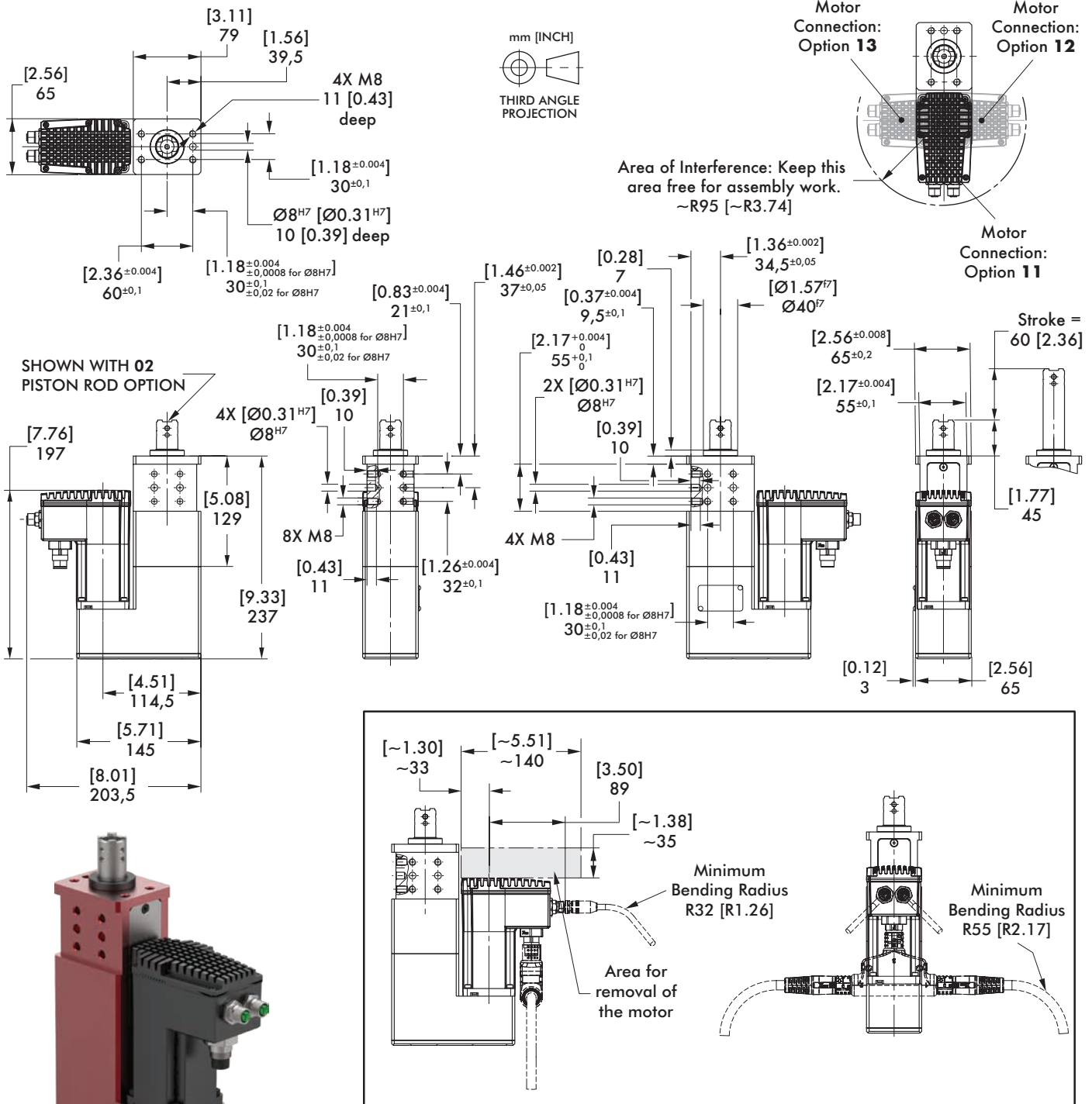

Base Model	Stroke mm [in]	Thrust Force N [lbf]	Retraction Force N [lbf]	Speed Max. mm/s [in/s]	Weight Kg [lbs]
96W-11.02..60	[0-2.36] 0-60	[225] 1000	[225] 1000	[2.36] 60	[13.01] 5,9

96W-1 PISTON RODS

Electric Pin Package | Smart Pin Package | Dimensions

02 Ø16 mm, Cross Groove

for Straight Motor Option 00, 01, 02 or 03 only

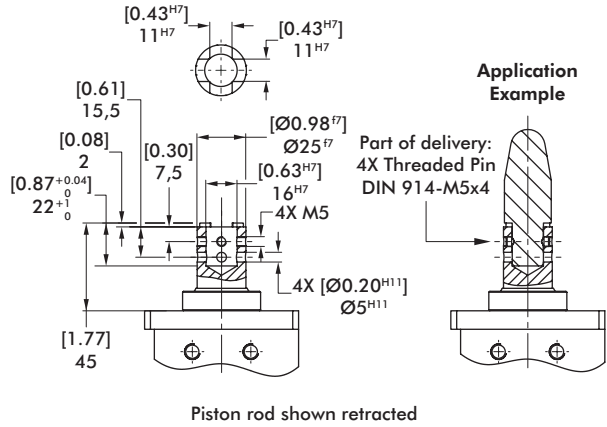

with M6 Threaded Inside Hole for Redirected Motor Option 10, 11, 12 or 13 only

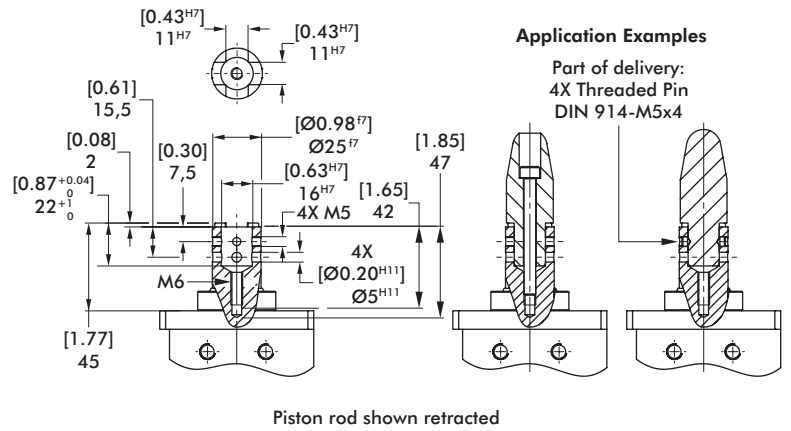

04, A4, B4, C4 NAAMS Standard

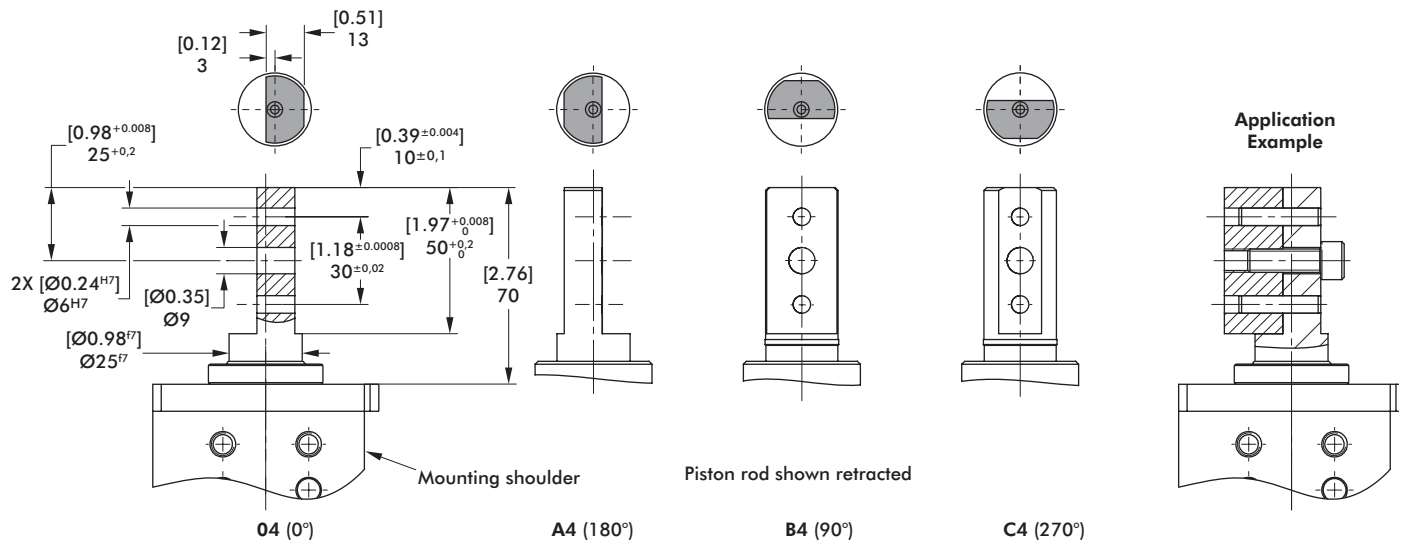

05 Ø10 mm Inside Hole, Cross Groove

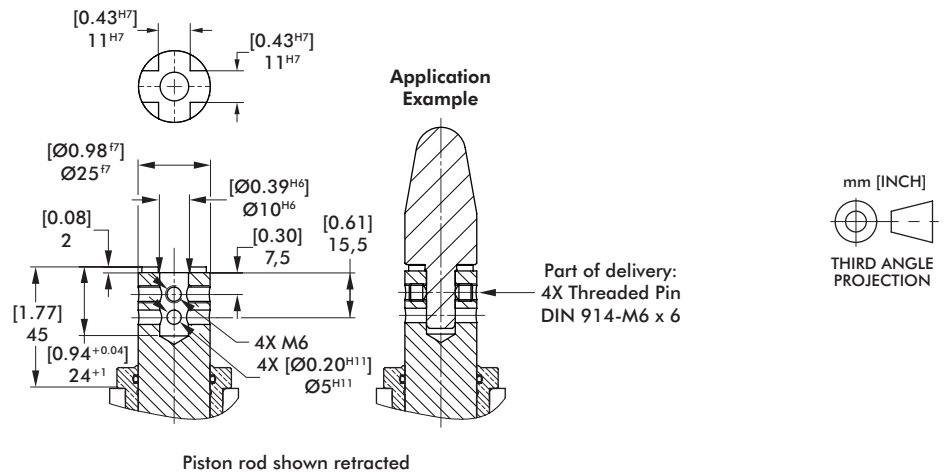

98W03-XXX

Electric Pivot Unit | Ordering Information

98W03 - 210 - C - 0 - 00 - 0

Motor	Drive Motor w/Brake
210	SEW 400 V for MOVIPRO
220	HEIDRIVE Servo Drive, Decentral 48 V
260	AMK Decentral 400 V
270	LENZE 400 V
310	SEW 400 V for MOVIMOT

Hard Stop	Description
0	Standard Stop

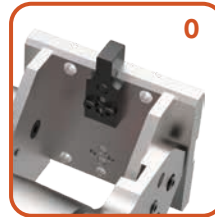

Motor Connections

0 Facing Back



Swivel Arm	Description
A	Center of Pivot Point
B	Below Pivot Point
C	Above Pivot Point

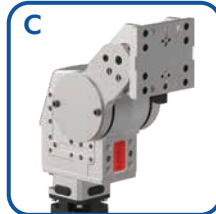
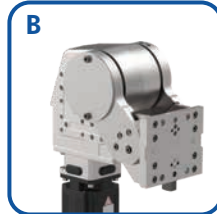
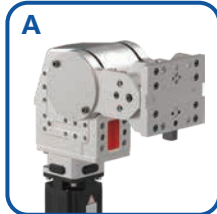

98W03-210C0-00-0

Holding Torque:
2000 Nm [1475 ft-lb]

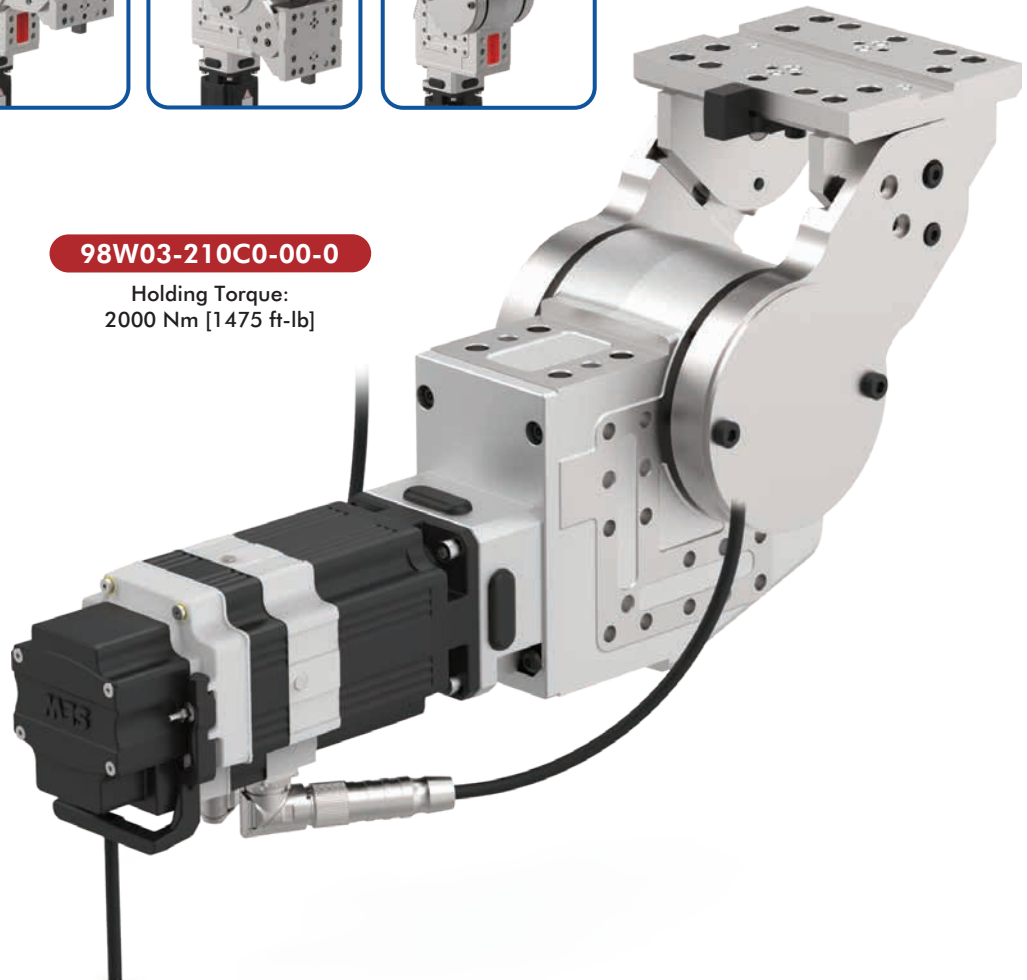

98W03-XXX

Electric Pivot Unit | Features and Benefits

Compact size and lightweight design

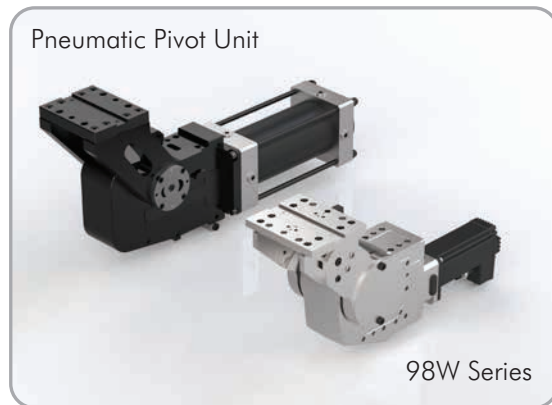

The 98W series electric pivot unit can share the same mounting pattern as the pneumatic pivot units, while providing greater energy savings with reduced size and weight.

One electric pivot unit replaces four sizes of pneumatic pivot units



98W03

Ø100

Ø125

Ø160

Ø200

Electric Pivot Unit

Pneumatic Pivot Units

Easily adjustable saddle arm and mount

The saddle arm of the electric pivot unit can be adjusted into three different starting positions. Each starting position allows the saddle arm to be pivoted from 135° up to 210°.

With out the saddle arm, the pivot unit can be used as a rotate with 360° rotation.

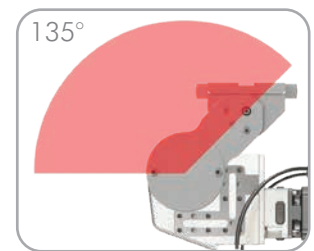
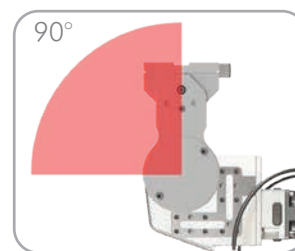
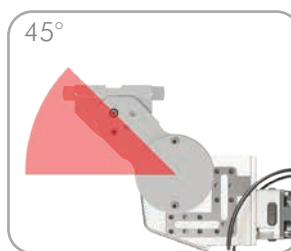

Application Example

98W Series shown with a holding fixture mounted to the saddle mount.



Operating Principle

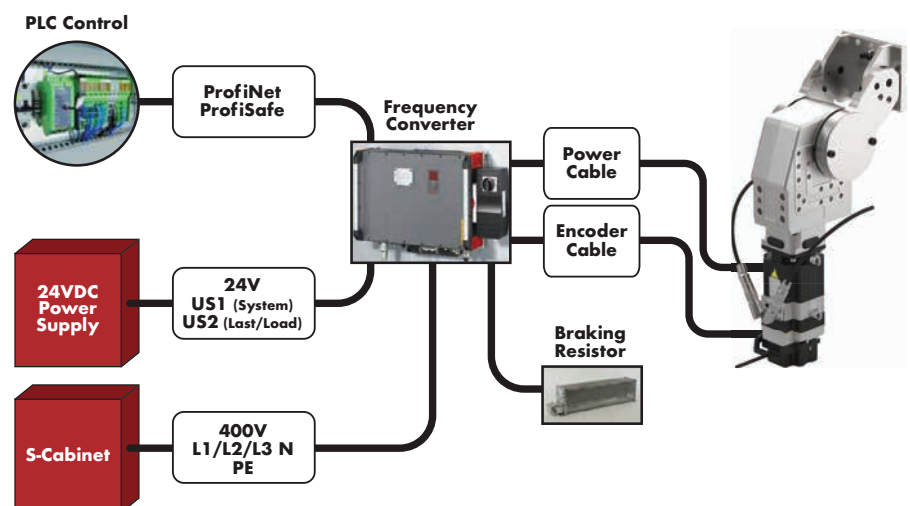

98W03-XXX

Electric Pivot Unit | Basic Unit Dimensions

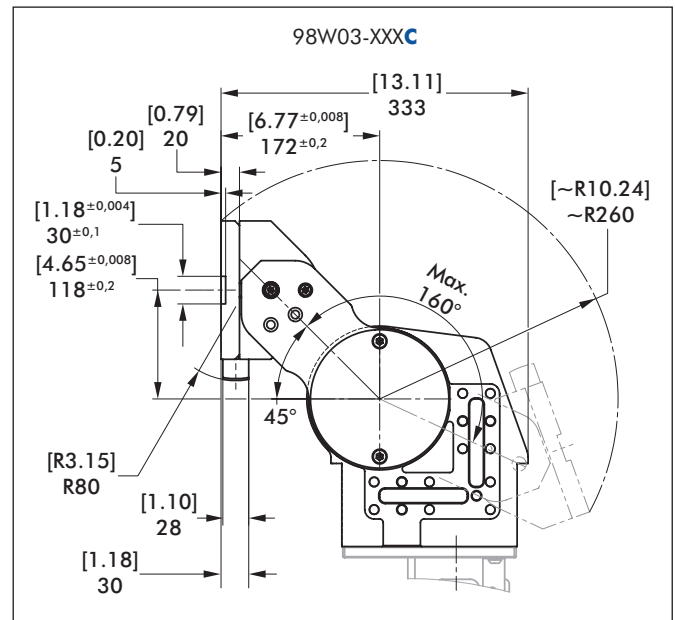
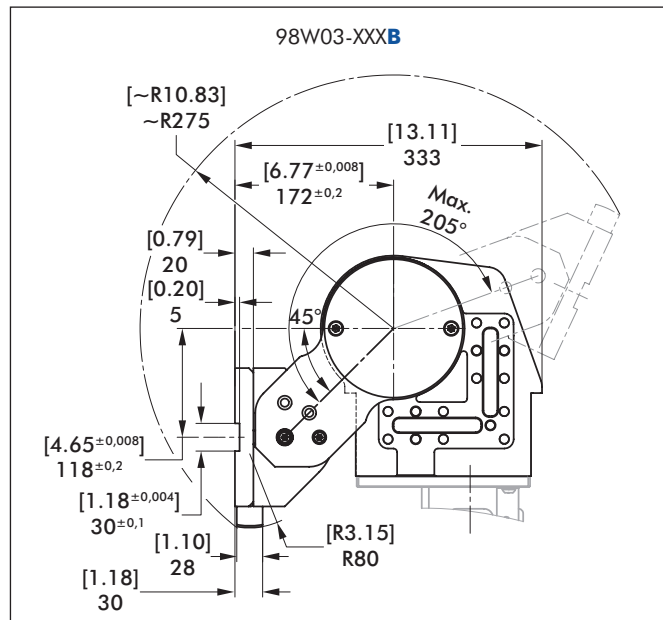
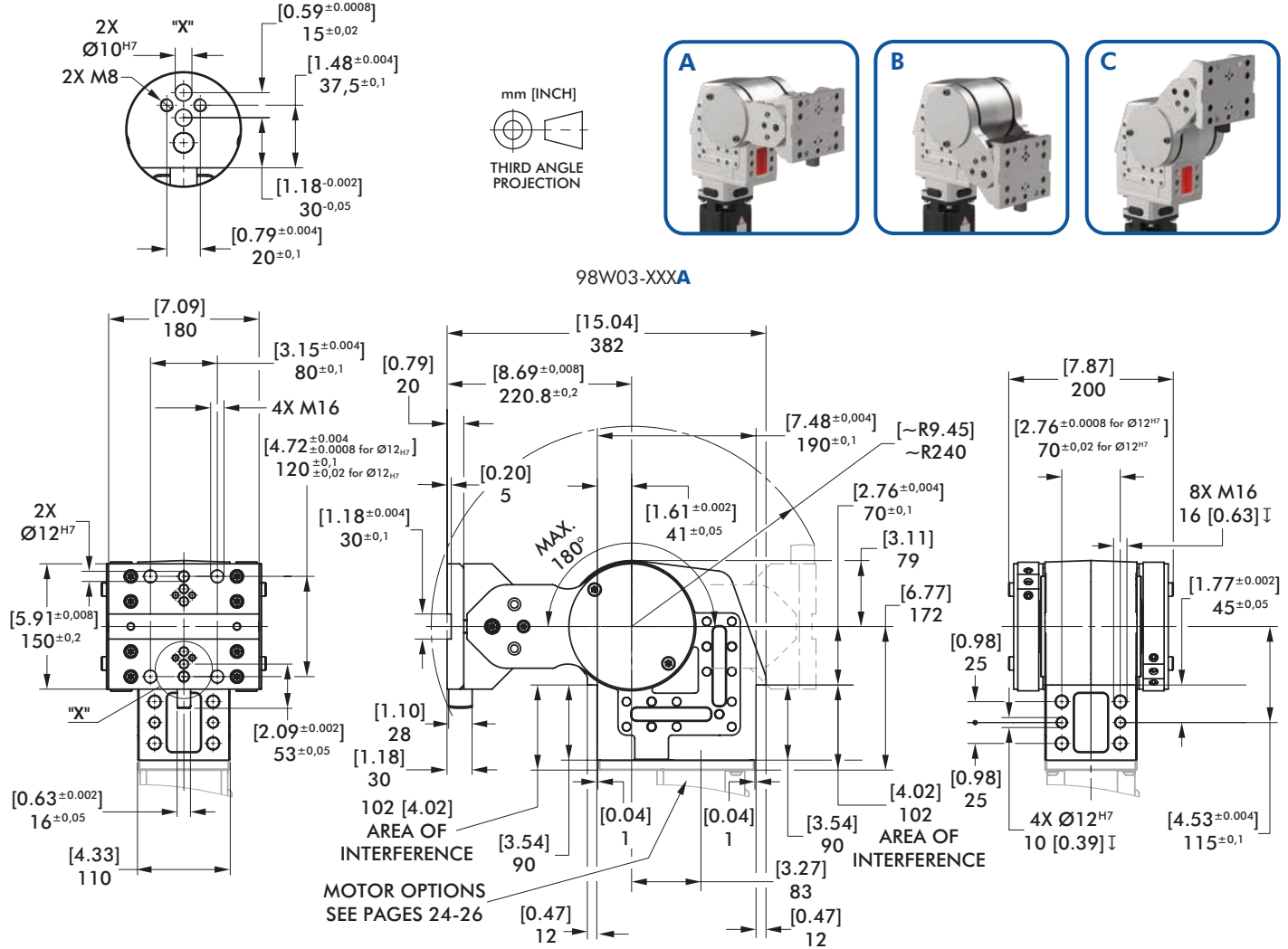

98W03-XXX MOTOR OPTIONS

Electric Pivot Unit | Motor Dimensions

98W03-210 SEW 400 V for MOVIPRO

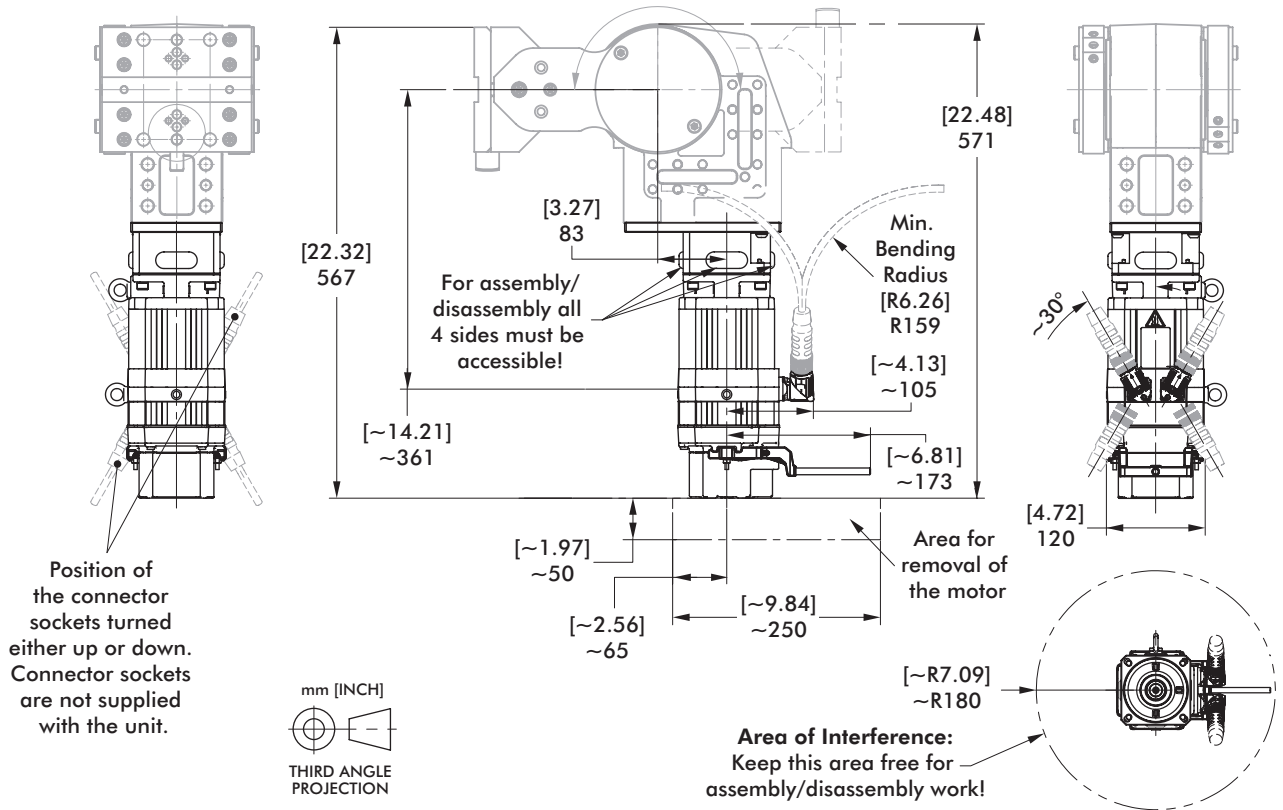

98W03-220 HEIDRIVE Servo Drive, Decentral 48 V

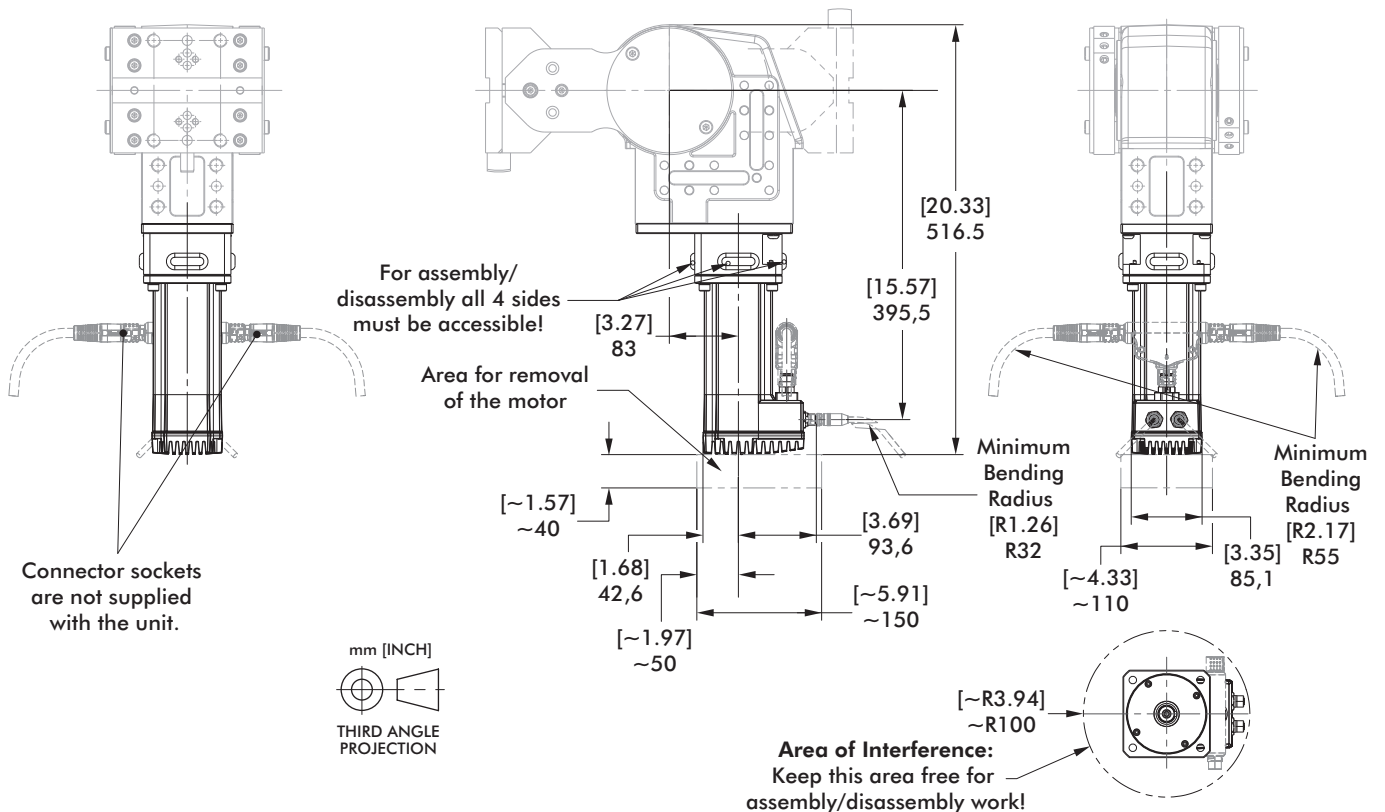

98W03-XXX MOTOR OPTIONS

Electric Pivot Unit | Motor Dimensions

98W03-260 AMK Decentral 400 V

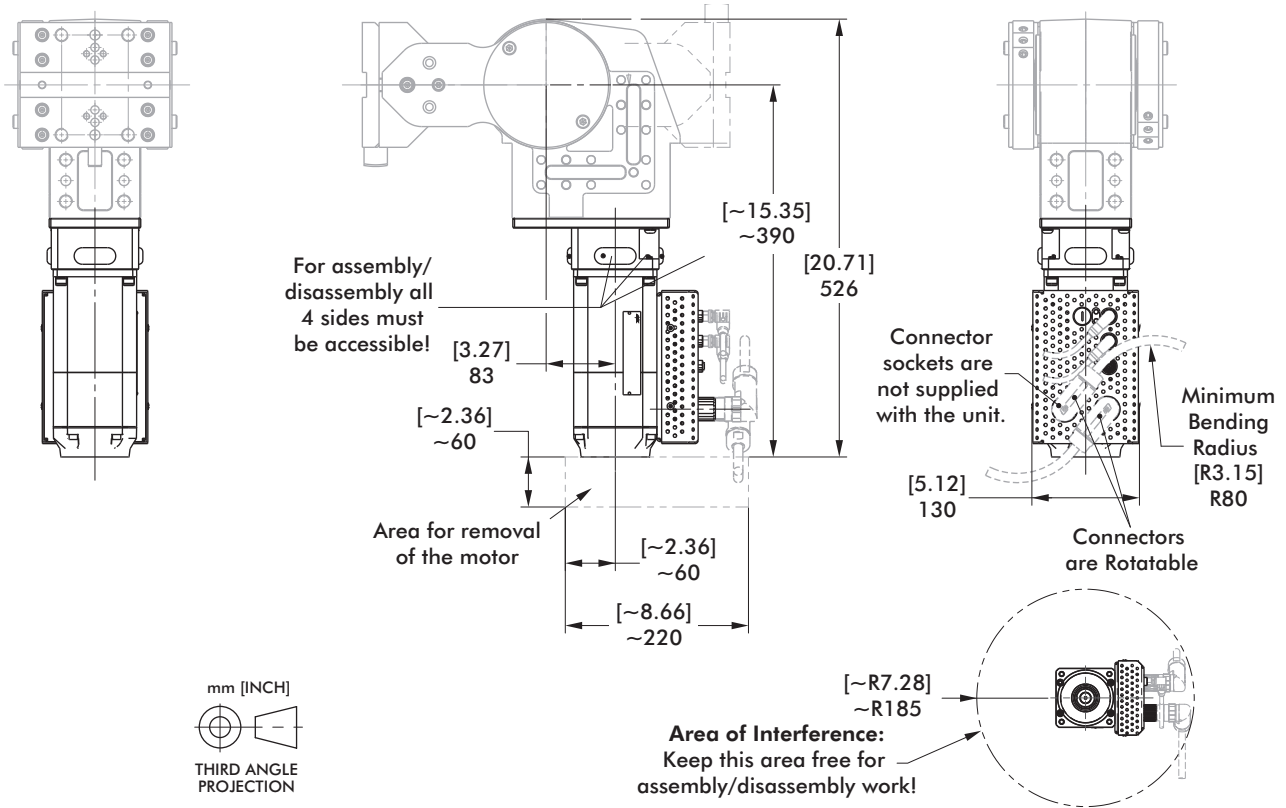

98W03-270 LENZE 400 V

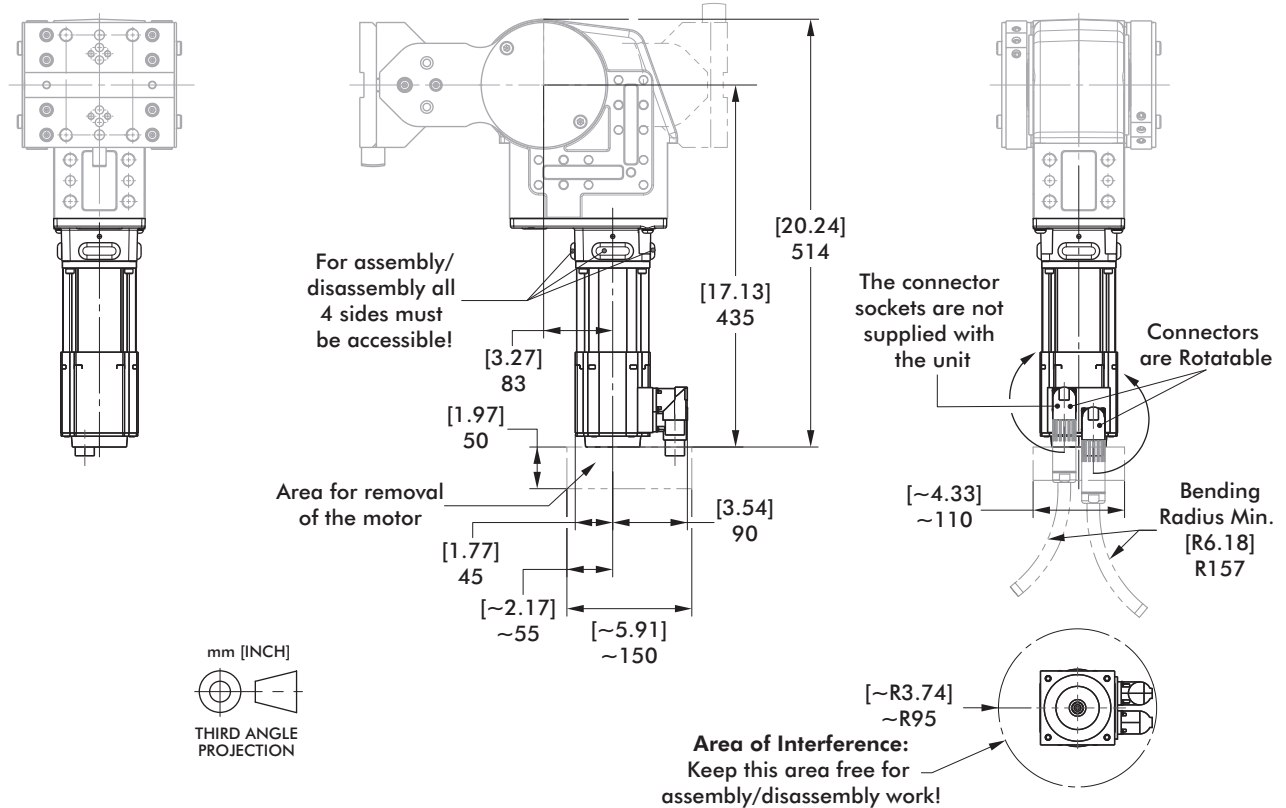

98W03-XXX MOTOR OPTIONS

Electric Pivot Unit | Motor Dimensions

98W03-310 SEW 400 V for MOVIMOT

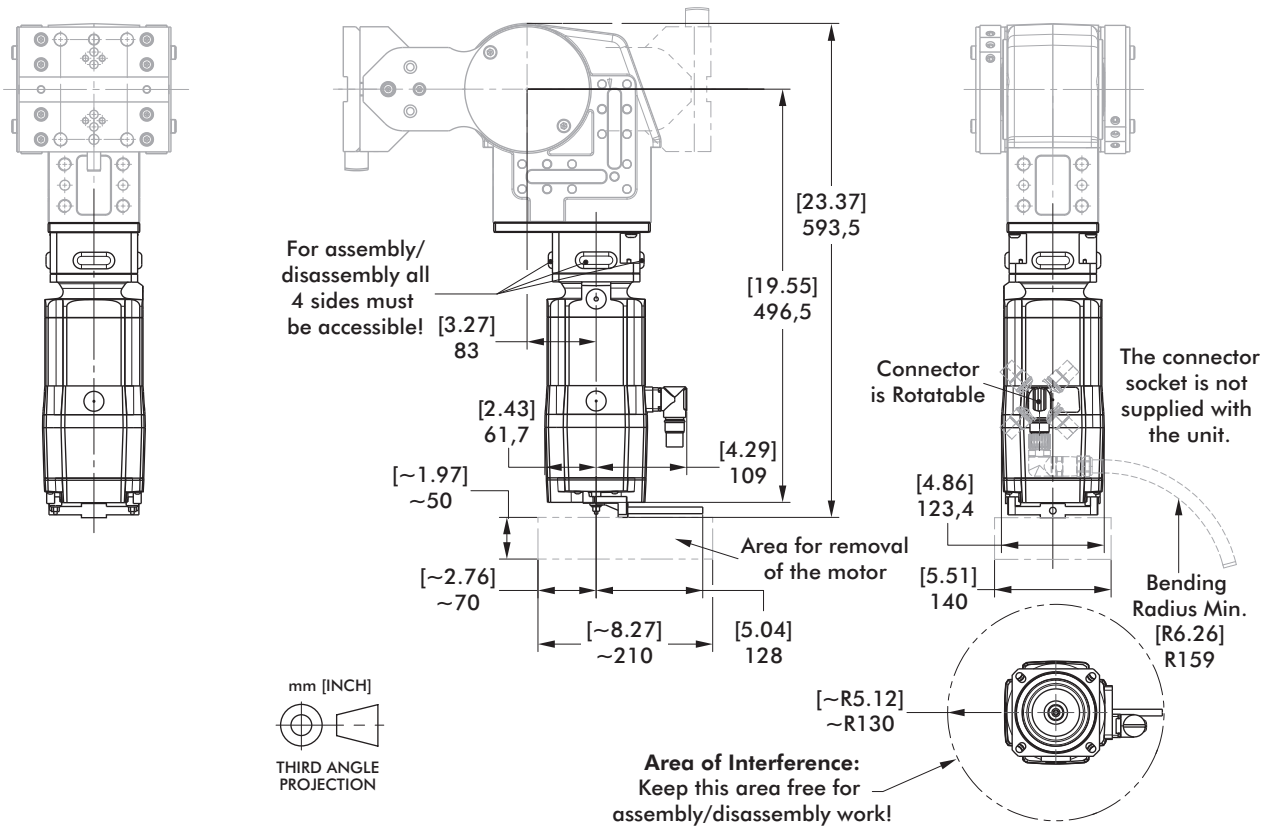

98W03-XXX

Electric Pivot Unit | Technical Specifications

Specifications	Units	98W03-210	98W03-220	98W03-260	98W03-270	98W03-310
Brake	V	400	24	400	24	400
Temperature	°C [°F]	0°-60° [32°-140°]				
Weight	kg [lbs]	~51,5 [~113.54]	~38,3 [~84.44]	~43 [~94.80]	~38,6 [~85.10]	48,2 [~106.26]
Connection Voltage of Control Control signals from external PLC Return signal to external PLC		400 VAC	48 VDC	400 VAC	400 VAC	400 VAC
Logic		N/A	24 VDC	N/A	N/A	N/A
Speeds:						
Drive from 135° to 0°	sec.	3.1 sec / 135°				
Drive from 0° to 135°	sec.					
Maximum Output Torque	Nm [ft-lbs]	500 [369]				
Maximum Holding Torque	Nm [ft-lbs]	2000 [1475]				
Gear Ratio		420:1				
Permissible Motor Torque (Motor torque must be limited on the control side)	Nm [ft-lbs]	6 [4.4]				
Permissible Motor Speed	RPM	6000 1/min Max.				
Switch On Time		70%				
Permissible Output Speed:						
Radial	N [lbf]	2000 [449.6]				
Axial	N [lbf]	5000 [1124]				
Below 45°	N [lbf]	1500 [337]				
Duty Cycle		70%				
E-Stop	N [lbf]	0.4 sec @ 500 [0.4 sec @ 112] = ca. 10°				
Acceleration	sec	2				
Slow down	sec	2				
Repeatability with Hard Stop	mm [in]	± 0,01 @ 500 [± 0.0004 @ 19.69]				
Repeatability w/o Hard Stop	mm [in]	± 0,05 @ 500 [± 0.002 @ 19.69]				

Driving Time and Angle Guidelines

Driving Angle	Driving Time	Max Speed	Jolt Time	Acceleration Ramp	Braking Ramp	Amplification X-Controller
Degrees	Sec.	RPM	Sec.	ms	ms	
15	1.4	4017	0.1	500	500	2.23
30	1.7	5862				
45	1.8	6000				
60	2.0					
75	2.3					
90	2.7					
105	3.0					
120	3.6					
135	4.0	5700				
150	4.5	5600				
165	5.0	4500				
180	5.5					
195	6.0					
210	6.5					

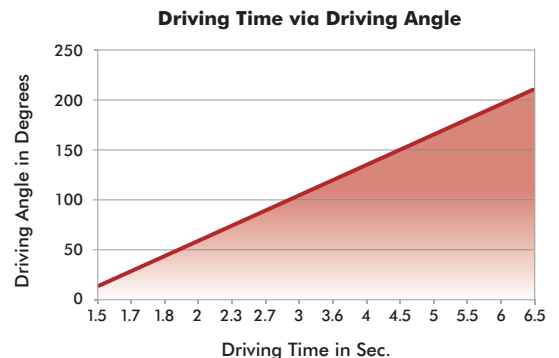

Note:
Maximum speed should not exceed 6000 rpm.
Velocity must never be in a trapezoidal profile.
The velocity must have a triangular or sinusoidal shape. Acceleration ramps or jolt tiles must be adjusted corresponding to the driving angle.

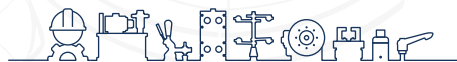

inf @ /CESEHSA.com.mx

