

Spidergrip Tooling Components

01/29/2025



info@cesehsa.com.mx

cesehsa.com.mx

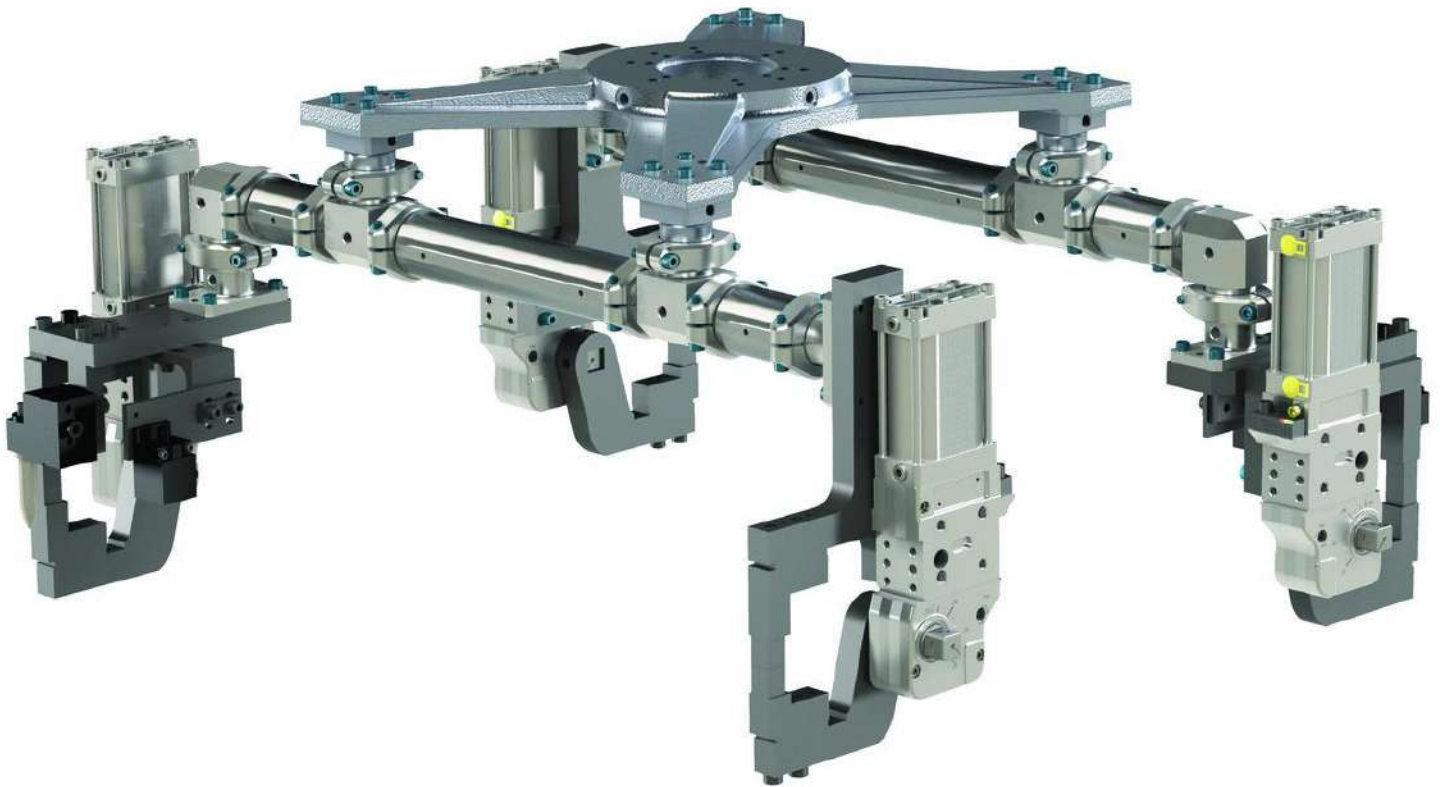

Spidergrip Tooling Components

01/29/2025

This catalog is a custom document and the products included is based on your unique selection from portions of complete catalogs that already exist. Please refer to our full catalogs for more information on products not included in this customized document.

Table of Contents

Spidergrip Tooling Components

EE-SGP-1

Spidergrip Tooling Components

01/29/2025

Table of Contents (continued)

SPIDERGRIP END EFFECTOR TOOLING SYSTEMS



Table of Contents

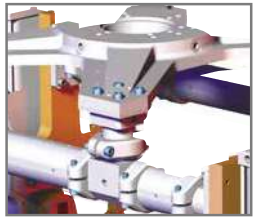

SpiderGrip Heavy Duty Mid Mount.....5



SpiderGrip Anchors and Collar Assemblies 10



SpiderGrip Booms, Adaptors, and Spacers 17



SpiderGrip Junction Components.....21



SpiderGrip Single End Extension Mount26



SpiderGrip Edge Mounting Components27



SPIDERGRIP GEOMETRIC END EFFECTOR SYSTEM

Spidergrip Tooling Components | Typical Application Build Examples

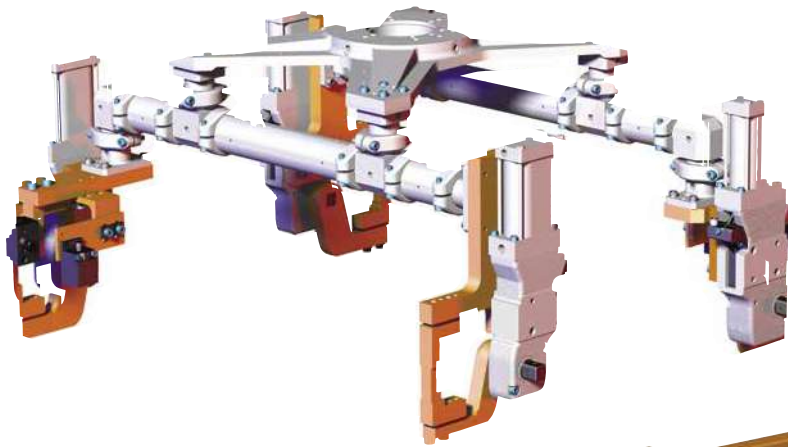

Materials Handling End Effector Tooling System with RM4 Heavy Duty Mid-Mount Assembly (RM4-STS).

Geometric End Effector Tooling System with Steel Frame Backbone.

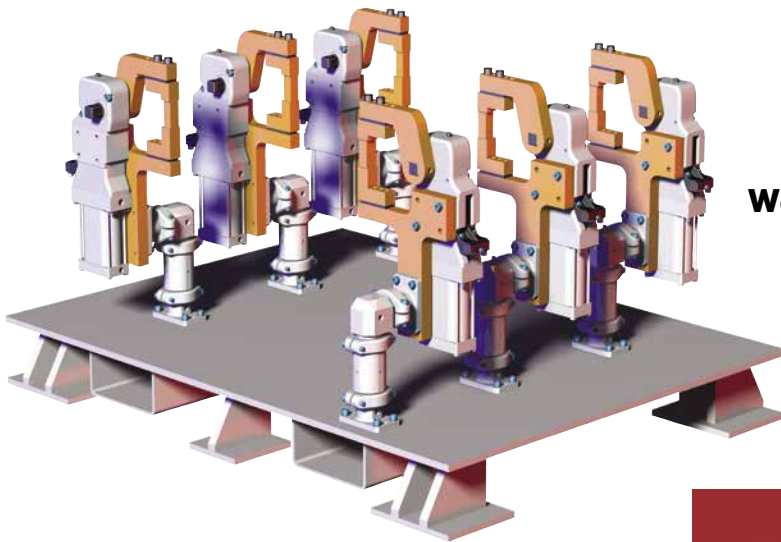
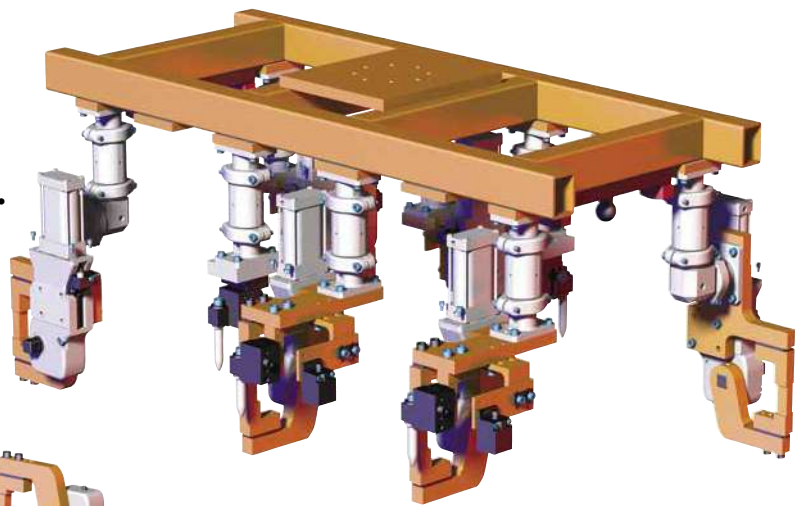

Weld Fixture Tooling System

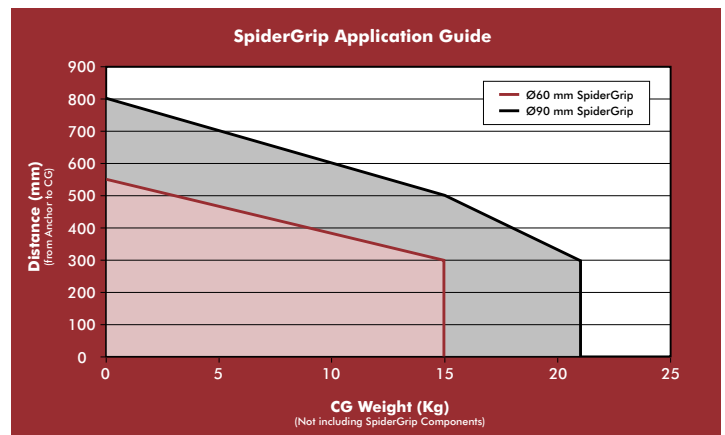

SPIDERGRIP GEOMETRIC END EFFECTOR SYSTEM

Product Overview



SpiderGrip Geometric End Effector Tooling System offers a standard cost effective solution by making it easy for each component to be replaced individually in the robotic cell, dramatically reducing production downtime and eliminating the need for a second end-effector.

This system is crash test certified and features automatic optical & standard CMM validation points.

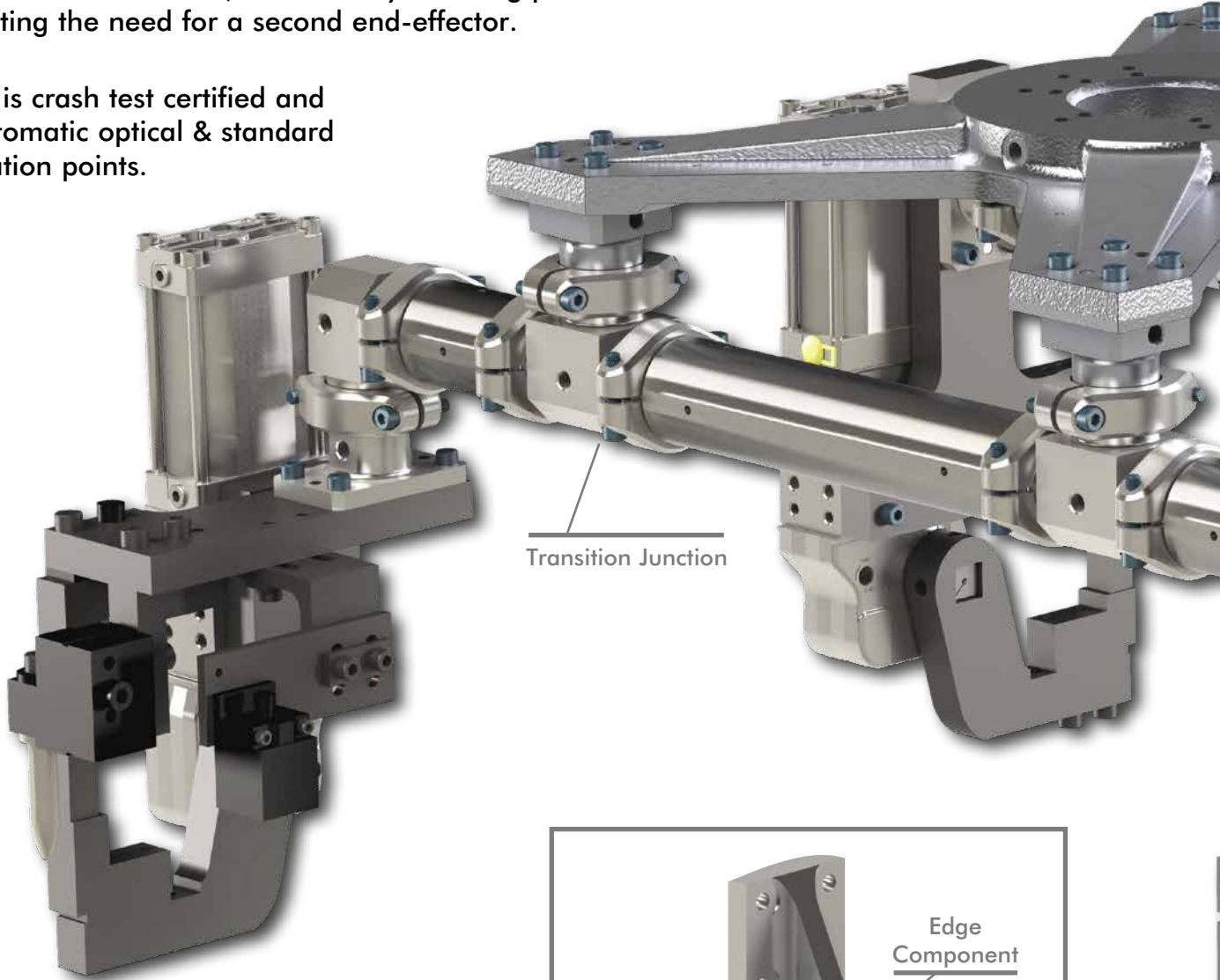

Spidergrip modular components are easily configurable and offer high strength to weight ratios while maintaining dimensional accuracy after continuous minor collisions. The patented collar/key design and engineered breakaway base anchor provides quick crash recovery.

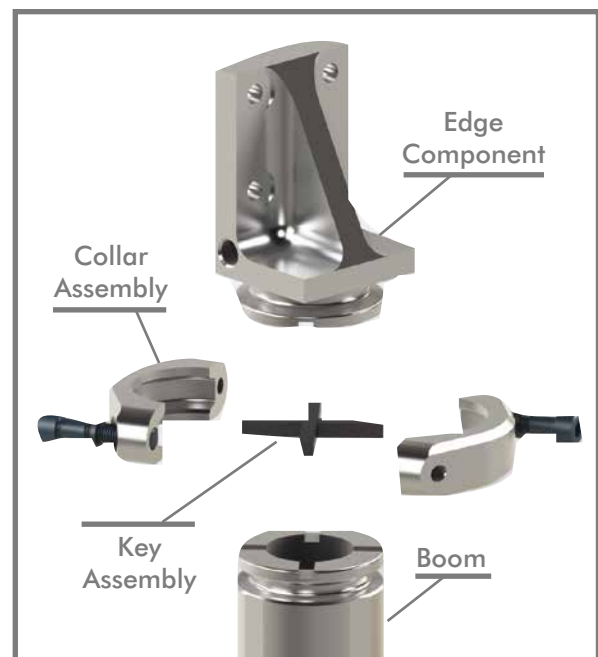

SPIDERGRIP GEOMETRIC END EFFECTOR SYSTEM

Product Overview

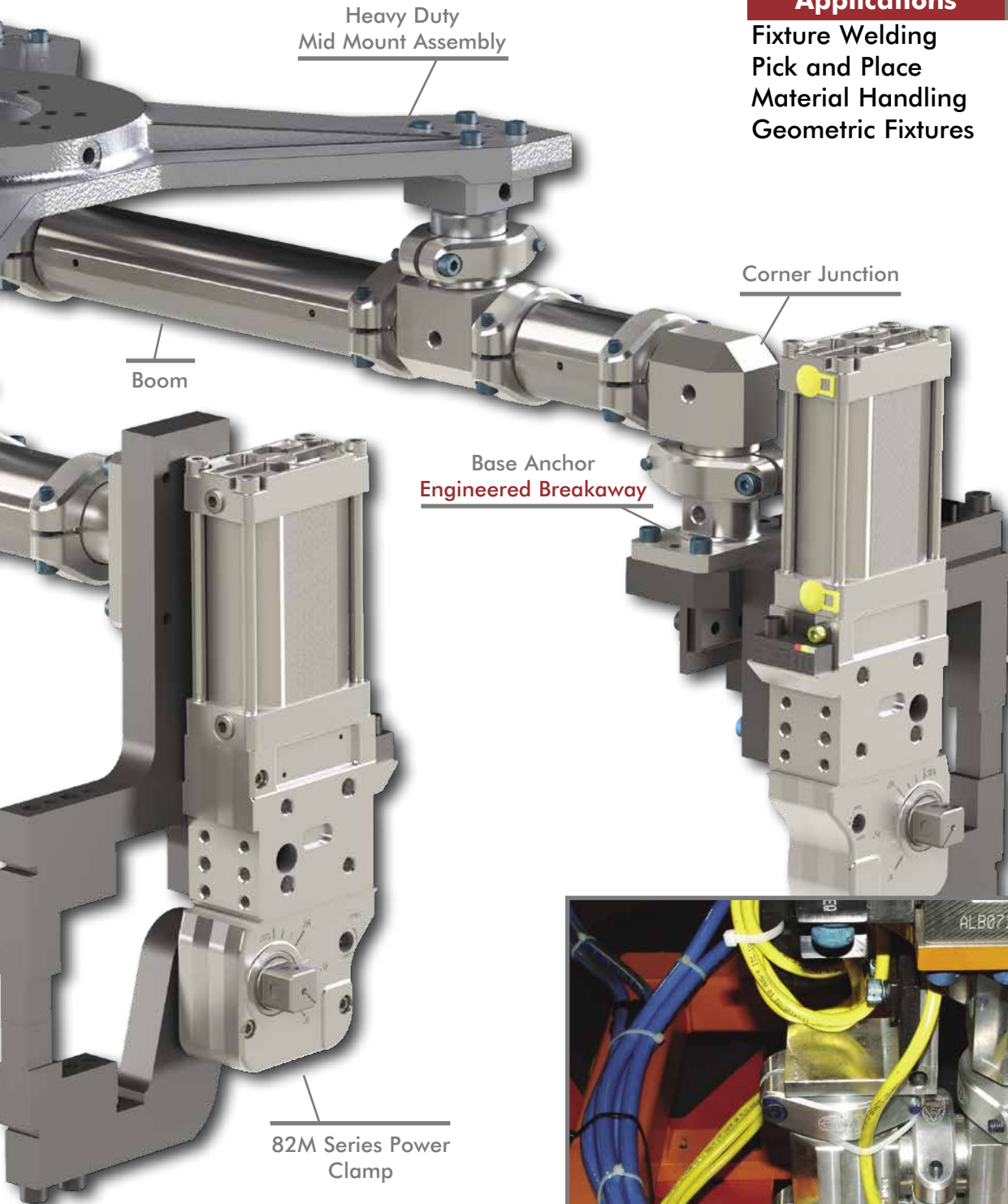

Most commonly used in:

Applications	Markets
Fixture Welding	Industrial
Pick and Place	Automotive
Material Handling	Aerospace
Geometric Fixtures	Appliance



SPIDERGRIP MID MOUNT ASSEMBLY



Spidergrip Tooling Components | Dimensions | How To Order

Heavy-Duty Mid Mount Assembly

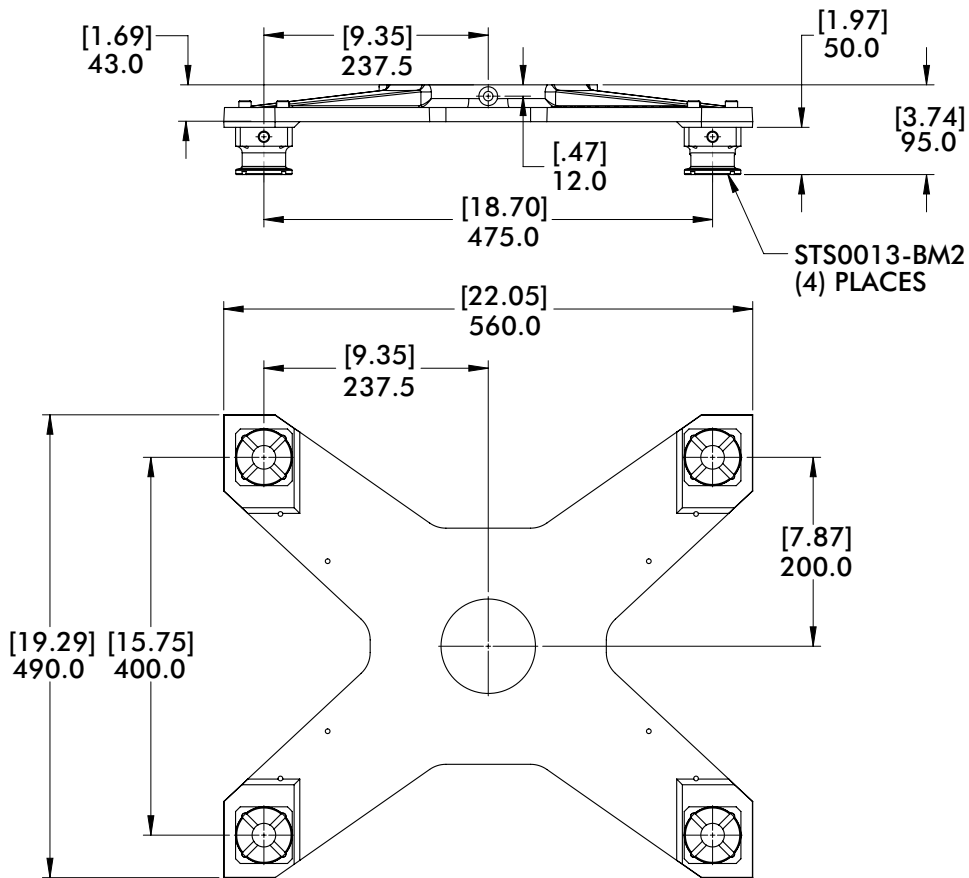
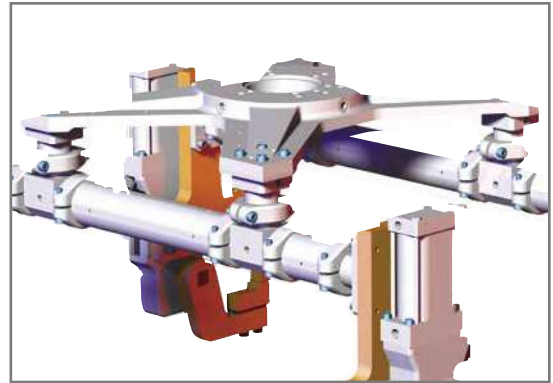

RM4-STS — **RXX** — **XX**

Model **Robot Interface Pattern** **Accessory**
 (e.g. EPM-01)
 (Leave blank if NONE)

Weight
 10.4 kg [22.89 lb]



SPIDERGRIP MID MOUNT ACCESSORY PLATE

Spidergrip Tooling Components | Dimensions | How To Order

Accessory Mount Plate

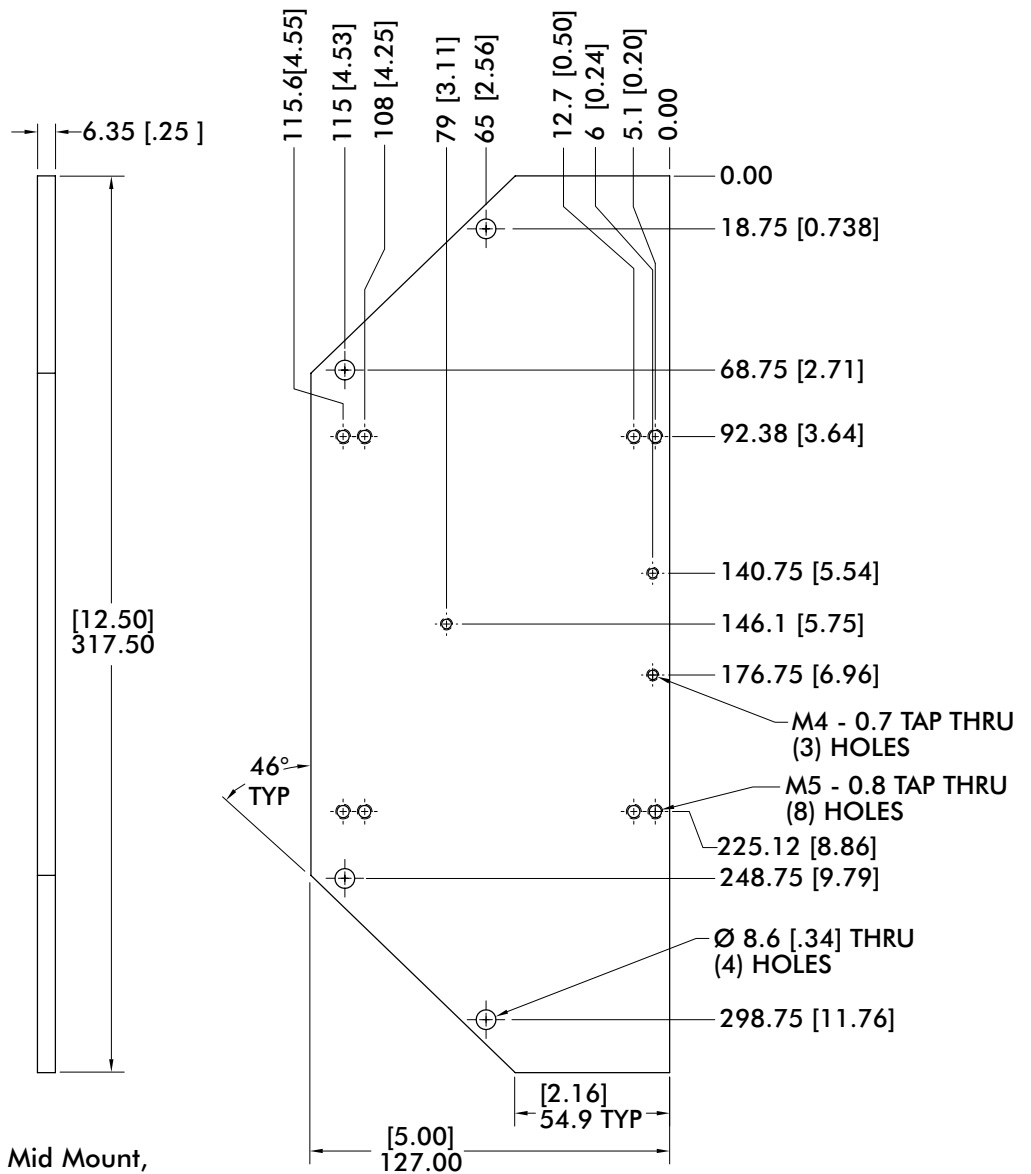
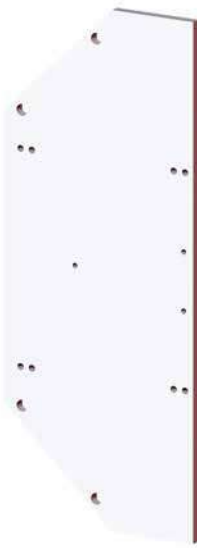
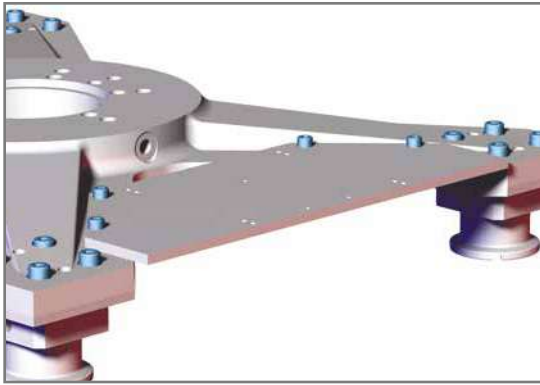

When ordering with Heavy Duty Mid Mount, please add designation "EPM-01" as shown RM4-ST5-RXX-EPM-01 or add designation "EPM-BLK" to order blank RM4-ST5-RXX-EPM-BLK To order separately use Model Number

Model Number	Weight
CPI-BM2-EPM-xx	.63 kg [1.39 lb]

MID MOUNT BOLT PATTERN

Robot Interface Bolt Patterns



R01 (Ø200mm Bolt Circle)

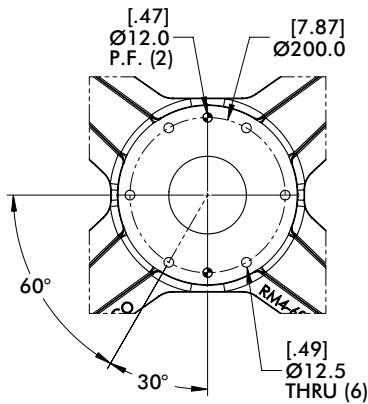
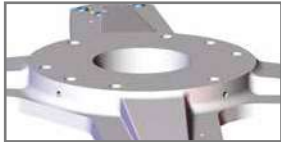

R02 (Ø125mm Bolt Circle)

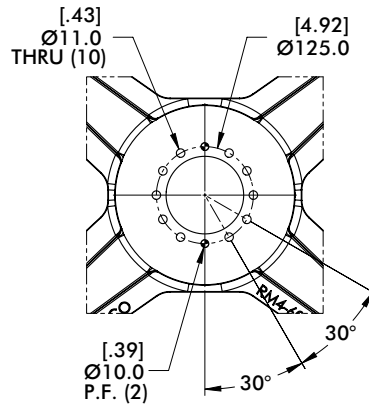
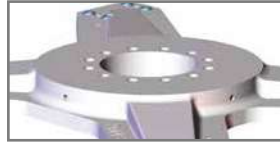

R03 (Ø160mm Bolt Circle)

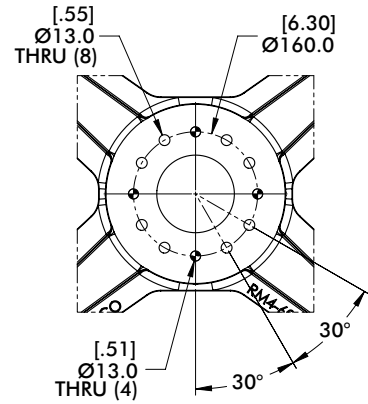
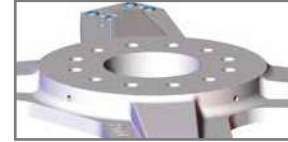

R04 (Ø160mm Bolt Circle)

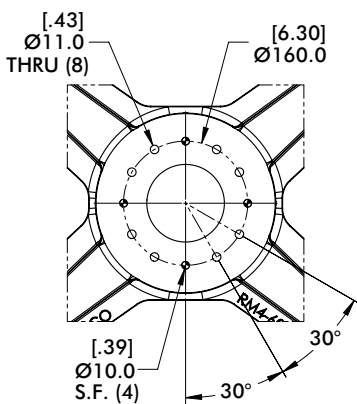
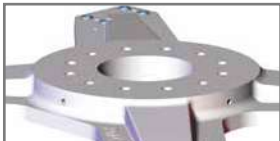

R05 (Ø125mm Bolt Circle)



Includes Insulation
Add 1.5mm to Height (95.0 [3.74])

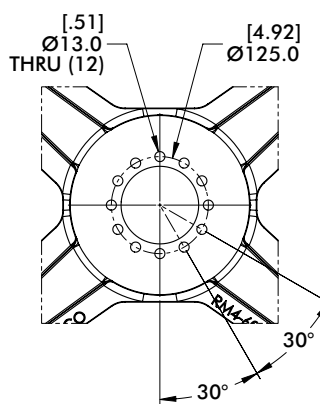

R06 (Ø125/160mm Bolt Circle)

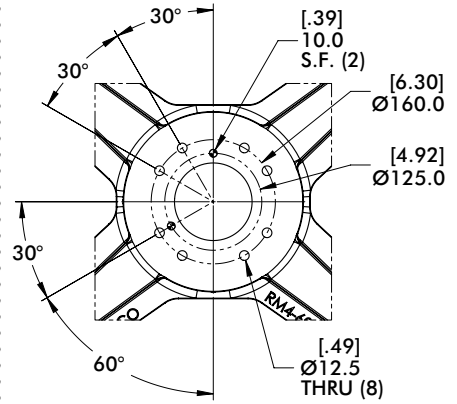



MID MOUNT BOLT PATTERN

Robot Interface Bolt Patterns



R07 (Ø200mm Bolt Circle)

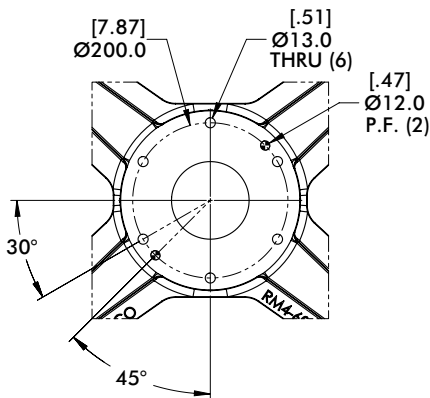
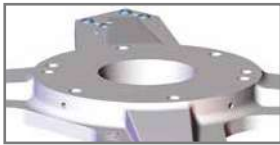

R08 (Ø125/160mm Bolt Circle)

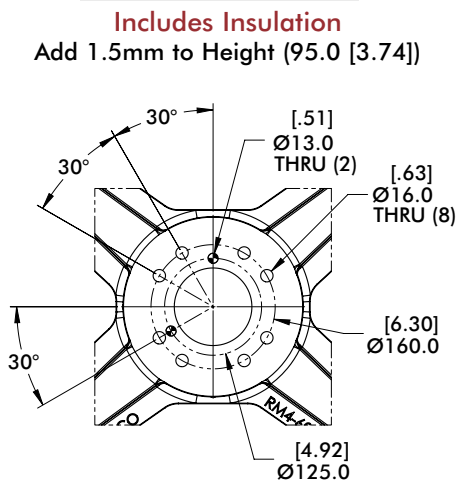
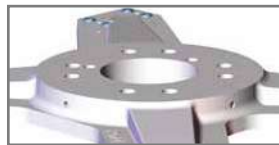

R09 (Ø200mm Bolt Circle)

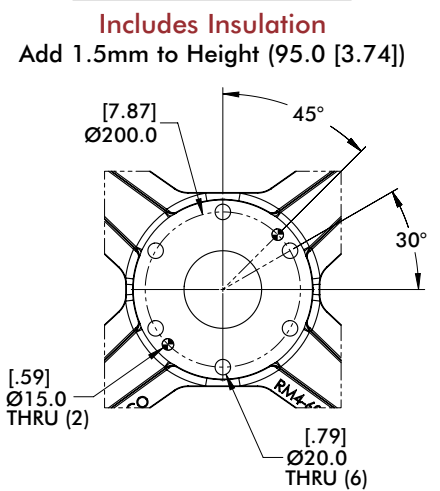
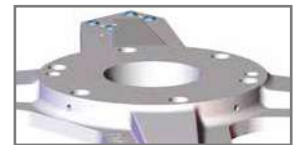

R10 (Ø200mm Bolt Circle)

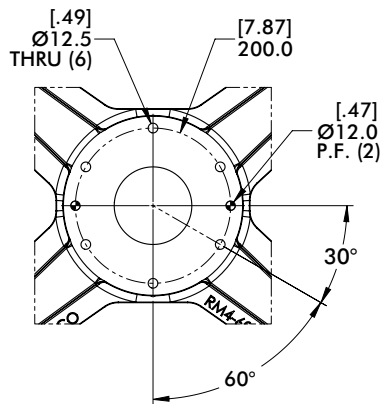
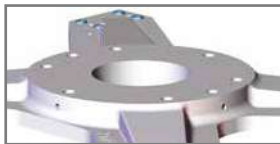

R11 (Ø200mm Bolt Circle)

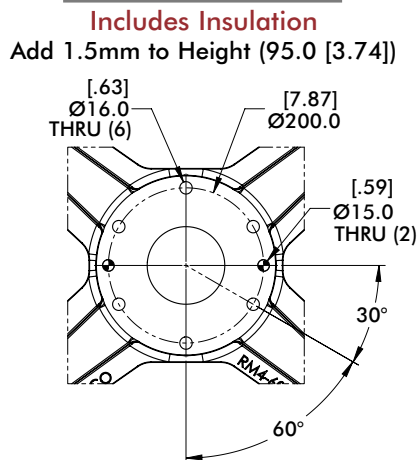
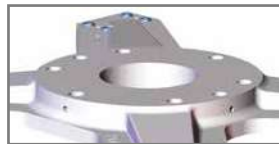

R12 (Ø160mm Bolt Circle)

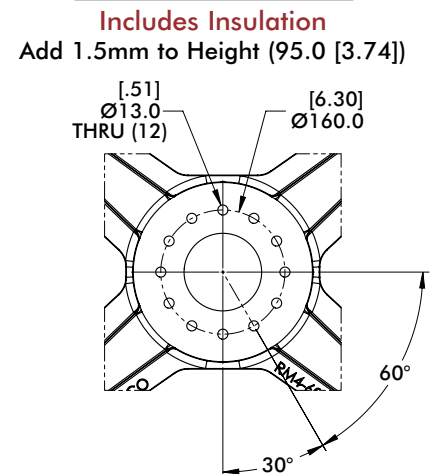
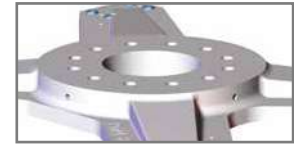

MID MOUNT BOLT PATTERN



Spidergrip Tooling Components | Robot Interface Bolt Patterns

**R13 (Ø125/160mm Bolt Circle)
(Ø110mm Pilot, 5.5mm Deep)**

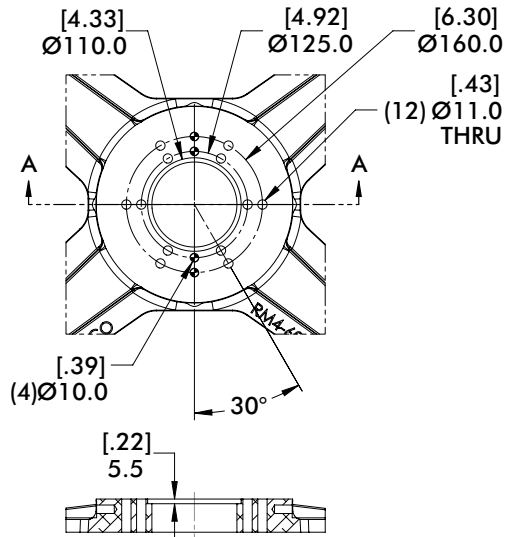
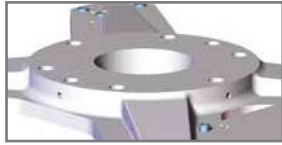

**R14 (Ø200mm Bolt Circle)
(Ø125mm Pilot, 11mm Deep)**

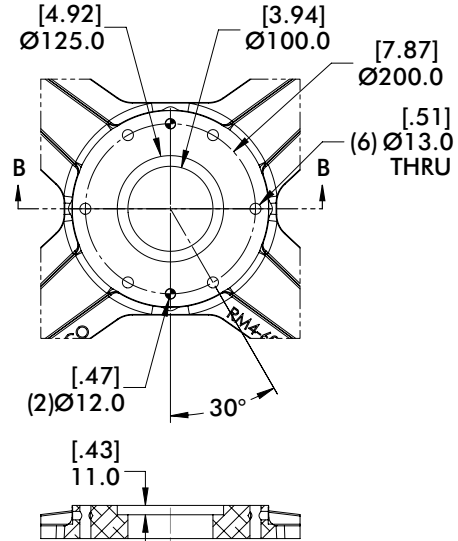
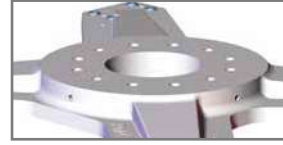

R16 (Ø200mm Bolt Circle)

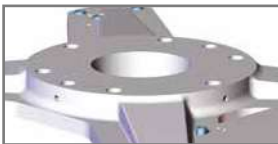

Includes Insulation
Add 1.5mm to Height (95.0 [3.74])

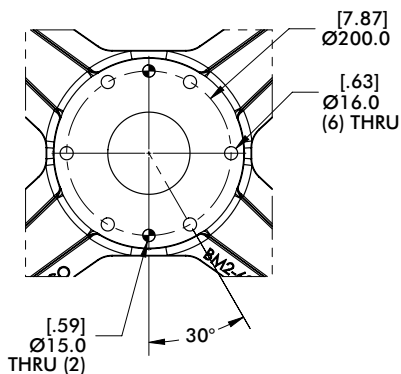

R17 (Ø160mm Bolt Circle)

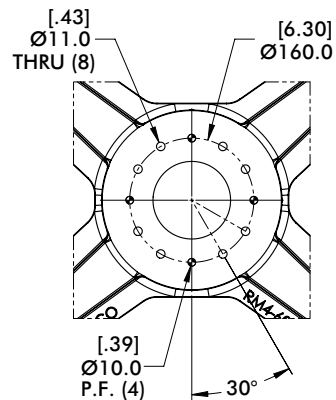
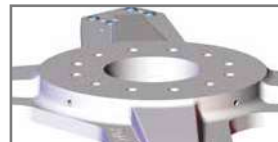



SPIDERGRIP MID MOUNT ANCHOR

Spidergrip Tooling Components | Dimensions | Technical Specifications

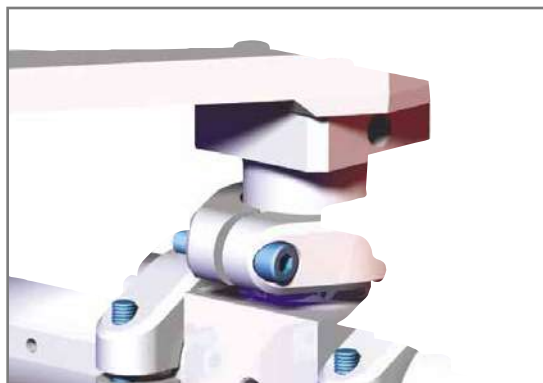

Ø60mm Mid Mount Anchor
40mm x 40mm Mounting Pattern - 50mm Face Offset

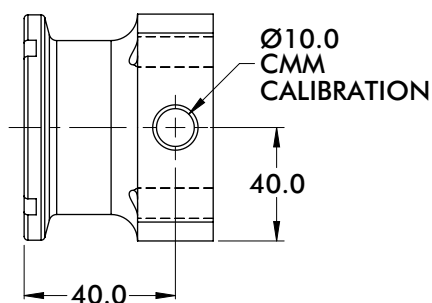
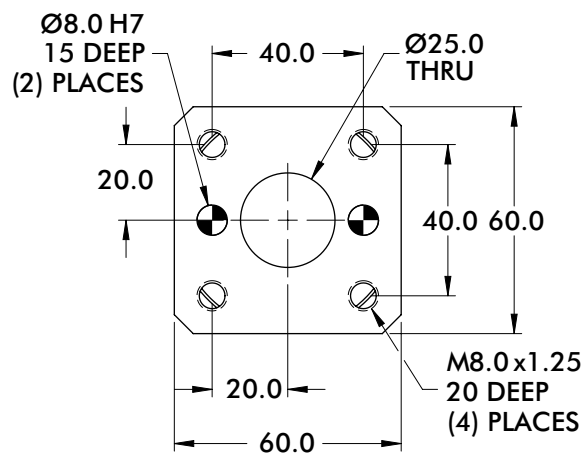
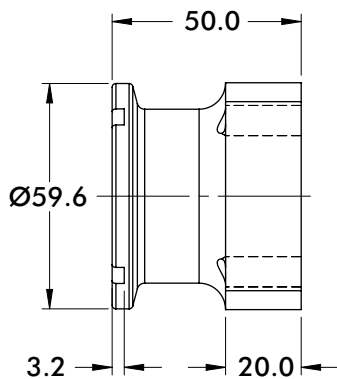
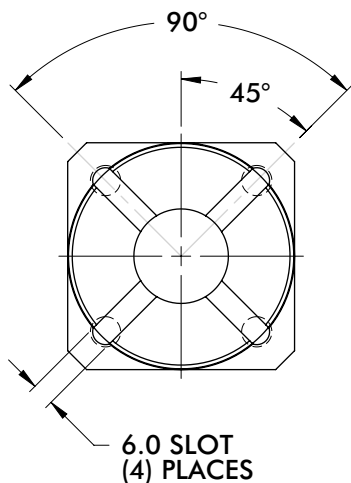
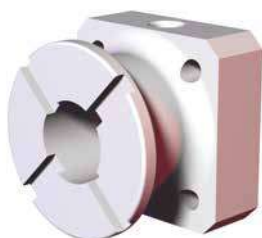

Model Number

Weight

STS0013-BM2

.25 kg [1.50 lb]

SPIDERGRIP MID MOUNT ANCHOR



Spidergrip Tooling Components | Dimensions | Technical Specifications

Ø60mm Base Anchor with 50mm Face Offset
80mm x 40mm Mounting Pattern



US PATENT# 7,331,104
ALL OTHER PATENTS PENDING

Engineered Breakaway Part

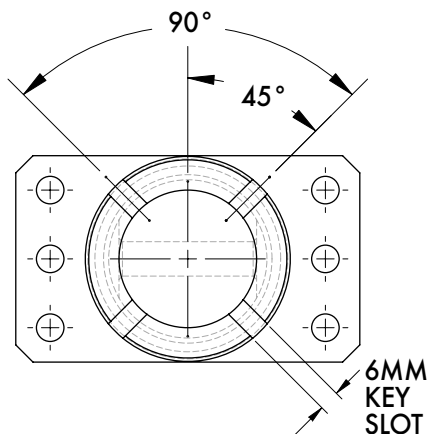
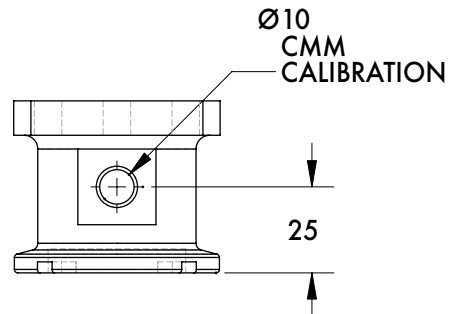
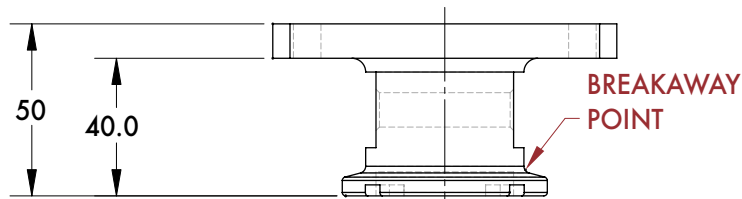
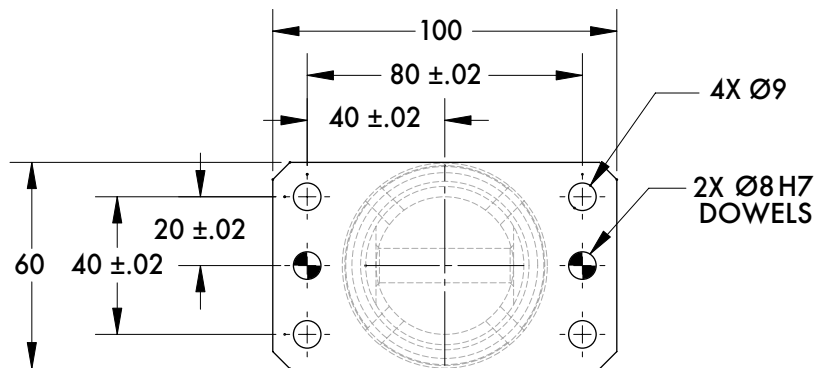

This Product is designed to breakaway
at 1627 N*m [1200 ft-lb]

Model Number	Weight
STS0016-NA-2P	.31 kg [.68 lb]



SPIDERGRIP MID MOUNT ANCHOR

Spidergrip Tooling Components | Dimensions | Technical Specifications



Ø60mm Base Anchor with 25mm Face Offset
(6) Hole Ø70mm Mount Pattern

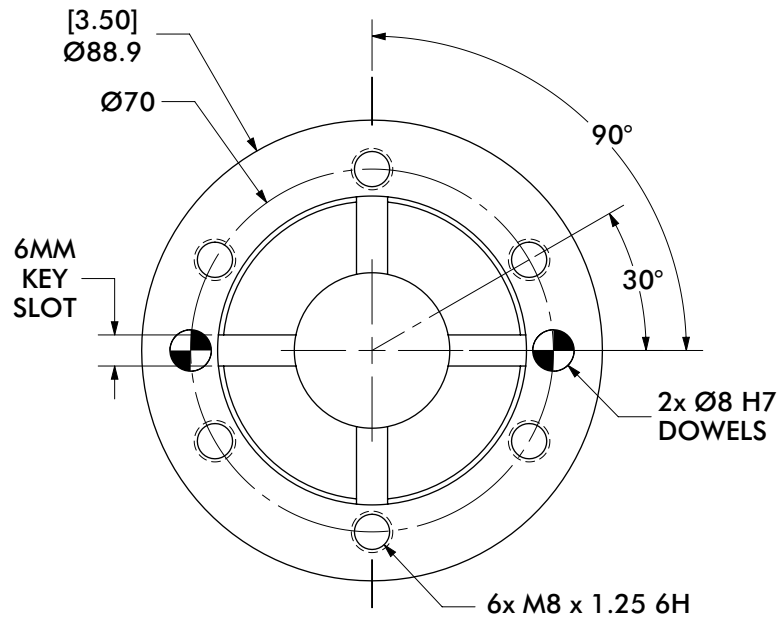
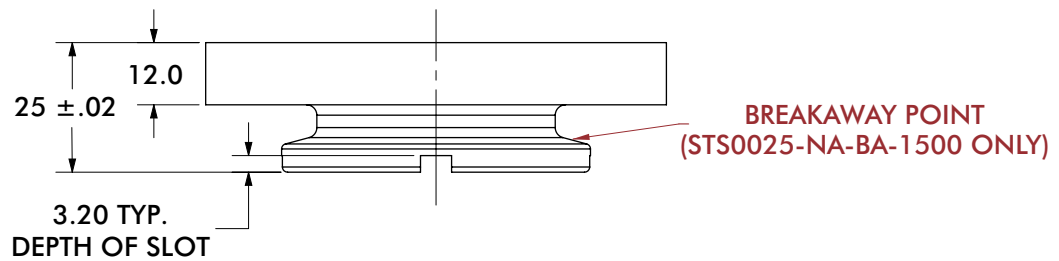

Model Number	Weight
STS0025-NA	252g [0.6 lb]
STS0025-NA-BA-1500*	242g [0.5 lb]

*This Product is designed to breakaway at 1500 N*m [1106 ft-lb]

SPIDERGRIP MID MOUNT ANCHOR



Spidergrip Tooling Components | Dimensions | Technical Specifications

Ø60mm HD Anchor Mount
(3) Hole Ø190mm Mount Pattern

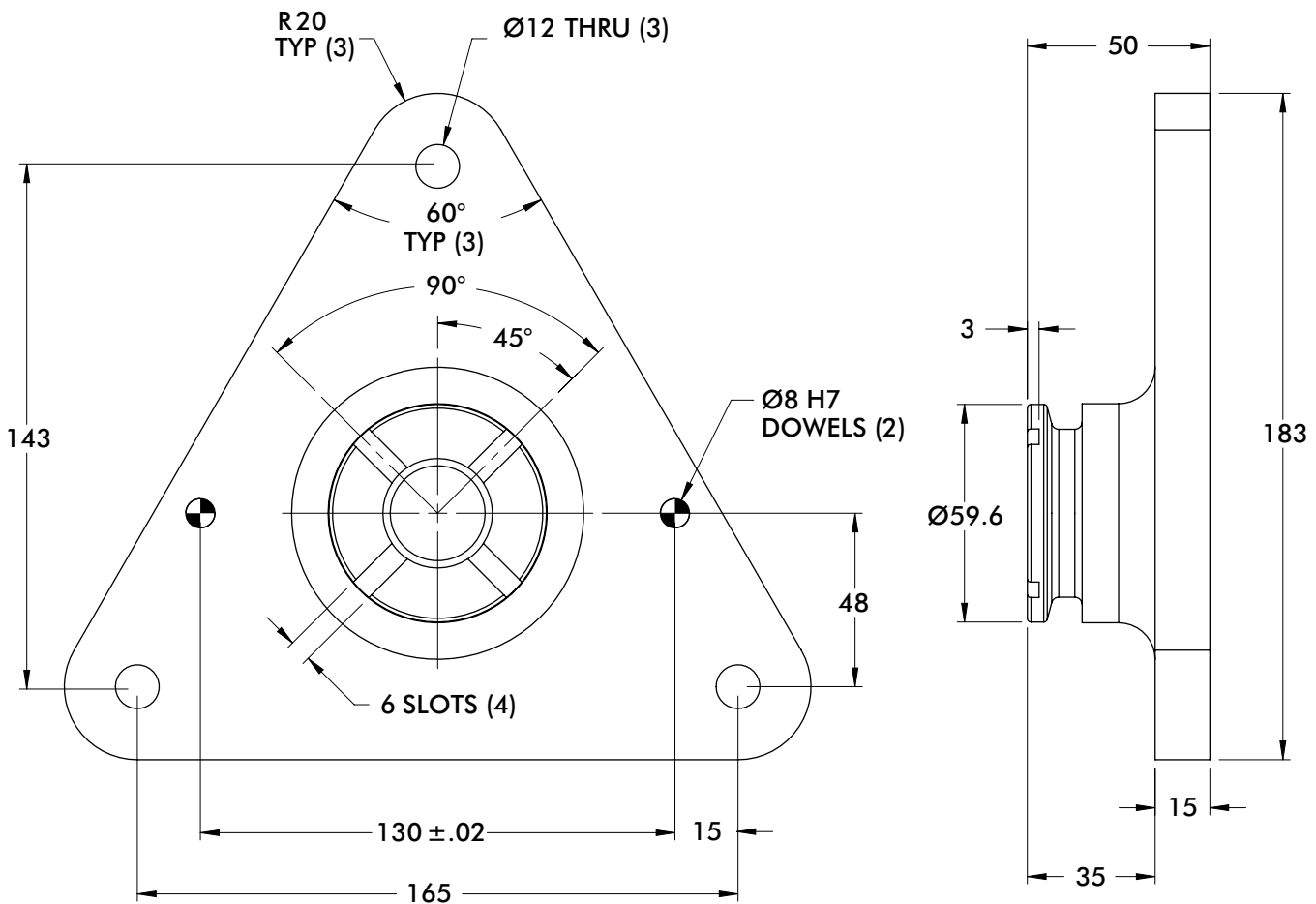
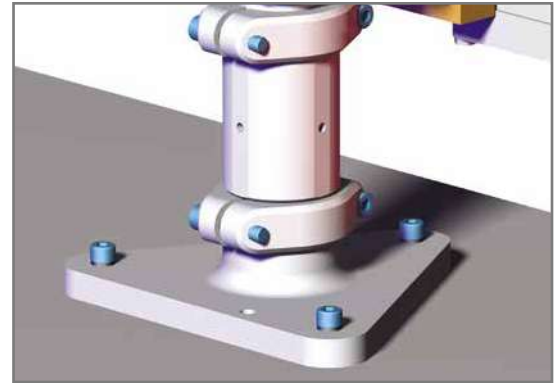

Model Number	Weight
STP0001-NA	1.09 kg [2.40 lb]



SPIDERGRIP END EFFECTOR TOOLING SYSTEMS

Spidergrip Tooling Components | Assembly Instructions

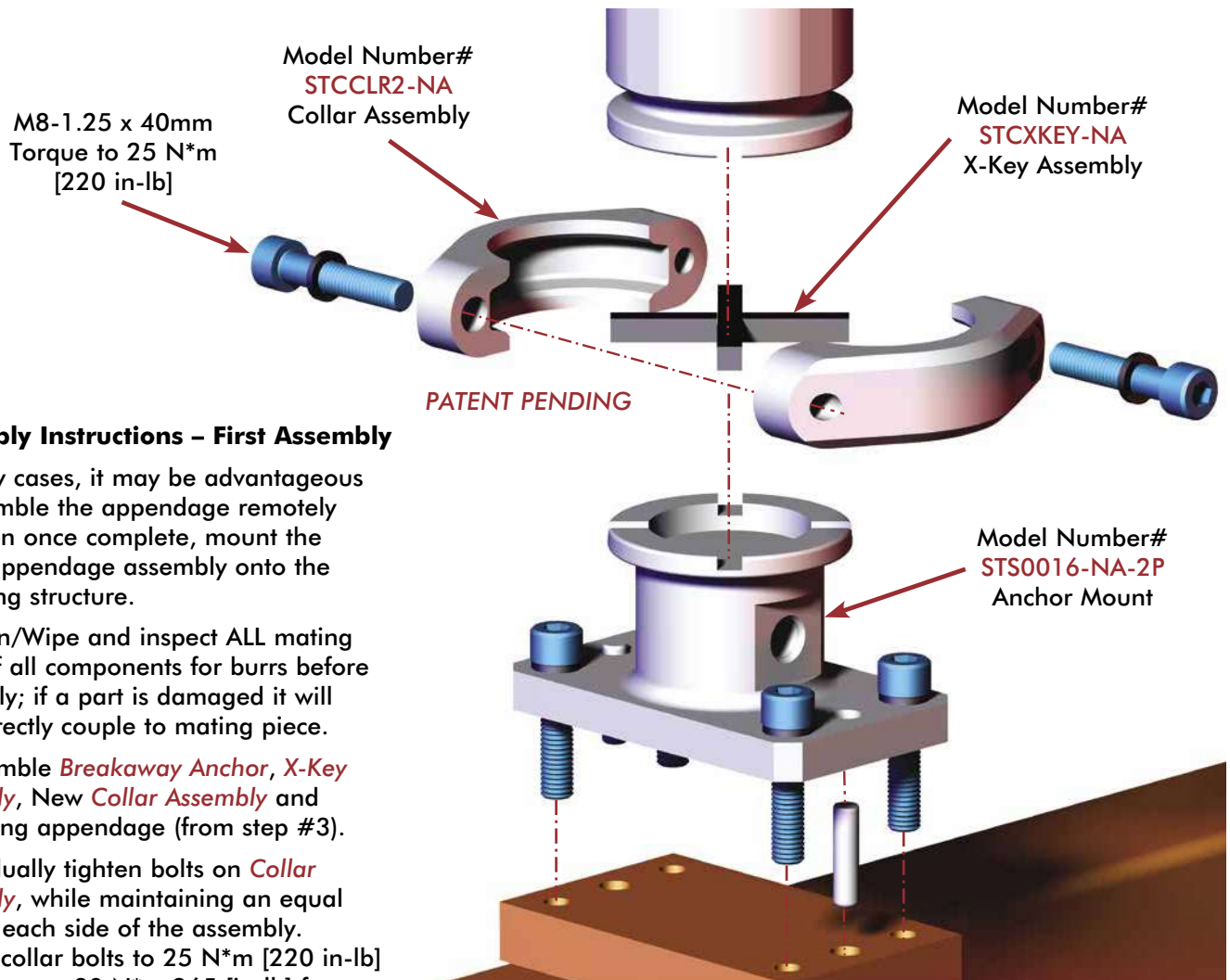

Assembly Instructions – First Assembly

In many cases, it may be advantageous to assemble the appendage remotely and then once complete, mount the entire appendage assembly onto the mounting structure.

1. Clean/Wipe and inspect ALL mating faces of all components for burrs before assembly; if a part is damaged it will not correctly couple to mating piece.
2. Assemble *Breakaway Anchor*, *X-Key Assembly*, New *Collar Assembly* and remaining appendage (from step #3).
3. Gradually tighten bolts on *Collar Assembly*, while maintaining an equal gap on each side of the assembly. Torque collar bolts to 25 N*m [220 in-lb] for 60mm, or 30 N*m 265 [in-lb] for 90mm. Do not re-torque once desired torque is reached.
4. Mount appendage as assembled to steel backbone and insert new 8mm dowels into the dowel holes on the *Breakaway Anchor*.
5. Insert new M8-1.25 patchlock bolts into *Breakaway Anchor*, torque in a cross pattern following NAAMS recommended torque.
6. Attach steel tether (*STS-TETHER-08* or *STS-TETHER-16*) to appendage via one of the bolts located on the base of the *Breakaway Anchor*. The other loop will be attached to the first threaded M6 hole (located on the boom) or the M8 hole located on the edge part. The tether may also be wrapped around the appendage to reduce cable slack.



Note: Performance may vary if used with non-DESTACO components

SPIDERGRIP ANCHORS AND COLLAR ASSEMBLIES



Spidergrip Tooling Components | Dimensions | Technical Specifications

Ø60mm Collar Components and Assembly

Assembly Number	Weight
STCCLR2-NA	.19 kg [.42 lb]

Includes (1) Collar Assembly (STCCLR2-NA) and (1) X-Key Assembly (STCXKEY-NA). Patch-lock fasteners included.

Max bolt torque when clamping to: 25 N*m [220 in-lbs]

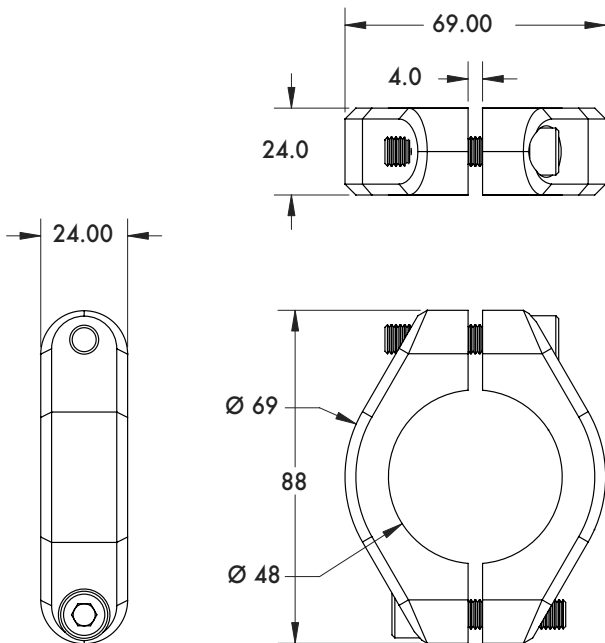
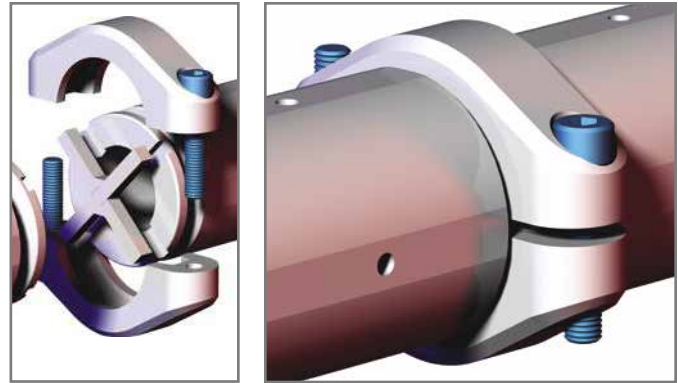

US PATENT# 7,331,104
ALL OTHER PATENTS PENDING



Patch-lock fasteners included.

Model Number	Weight
STCCLR2-NA	.16 kg [.35 lb]

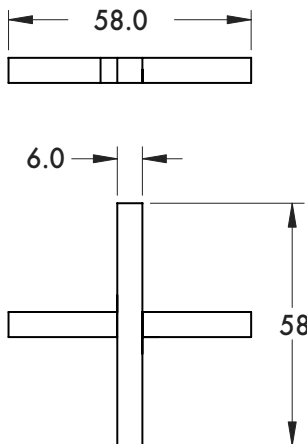

Material: Steel

Model Number	Weight
STCXKEY-NA	.03 kg [.07 lb]



SPIDERGRIP TETHERS

Spidergrip Tooling Components | Dimensions | Technical Specifications

9 inch and 16 inch Tether Assemblies

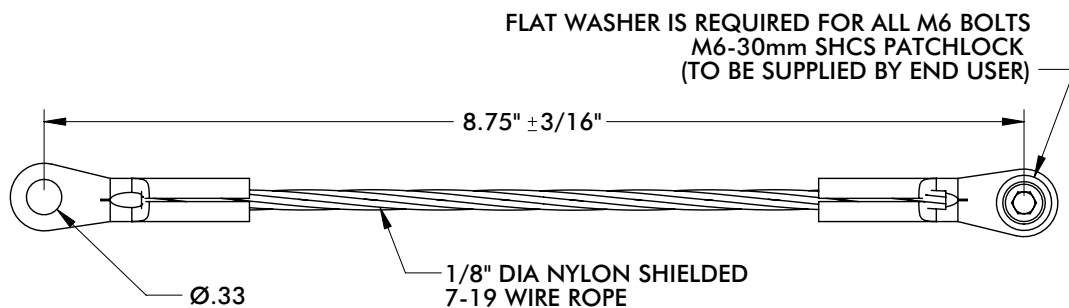
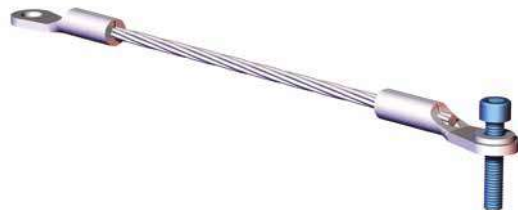

Model Number	Weight
STS-TETHER-09	.07 kg [.15 lb]

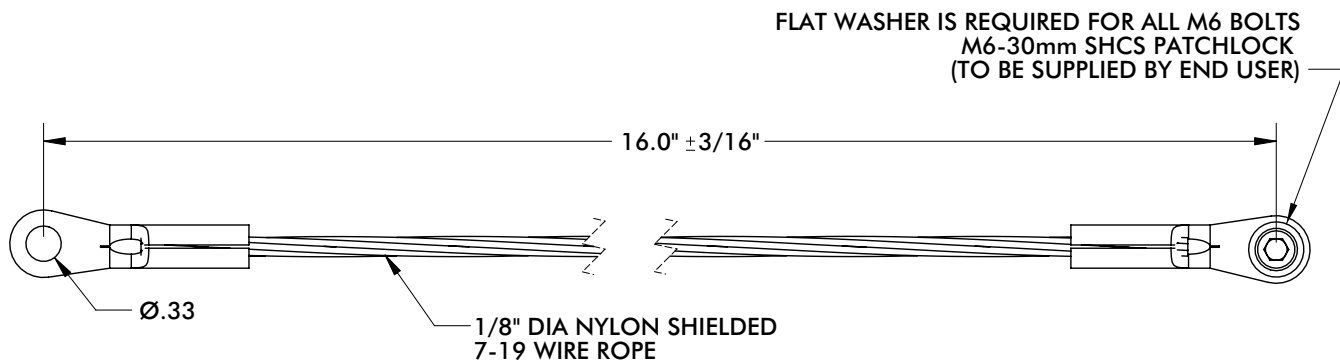

Model Number	Weight
STS-TETHER-16	.09 kg [.19 lb]

SPIDERGRIP BOOMS, ADAPTORS AND SPACERS



Spidergrip Tooling Components | Dimensions | Technical Specifications

Ø60mm Boom

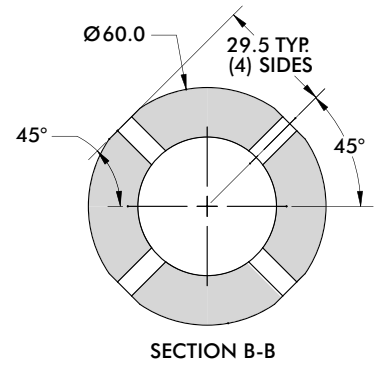
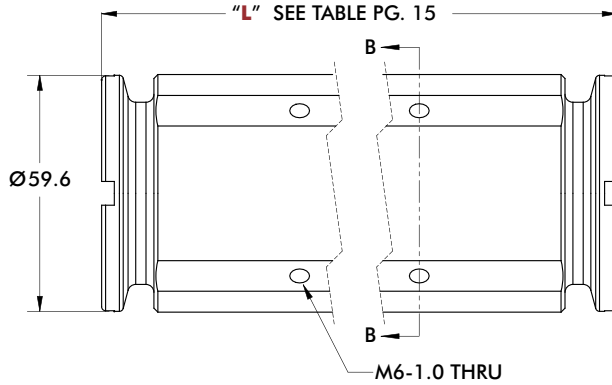
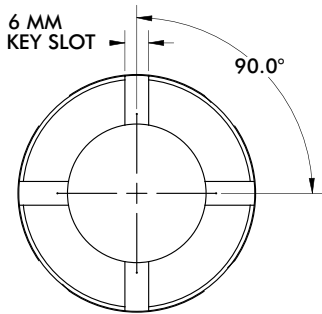

M6 tap holes along the boom are used to mount accessories

M6 Hole Spacing	Model Number	Length "L"	Weight
	STB0050-NA	50mm ±0.02	.20 kg [.43 lb]
	STB0075-NA	75mm ±0.02	.32 kg [.71 lb]
	STB0100-NA	100mm ±0.02	.45 kg [.99 lb]
	STB0150-NA	150mm ±0.02	.70 kg [1.54 lb]
	STB0200-NA	200mm ±0.02	.95 kg [2.09 lb]
	STB0250-NA	250mm ±0.02	1.20 kg [2.64 lb]
	STB0300-NA	300mm ±0.02	1.44 kg [3.18 lb]
	STB0350-NA	350mm ±0.02	1.74 kg [3.84 lb]



SPIDERGRIP BOOMS, ADAPTORS AND SPACERS

Spidergrip Tooling Components | Dimensions | Technical Specifications



Ø60mm Breakaway and Non-Breakaway Boom Spacers

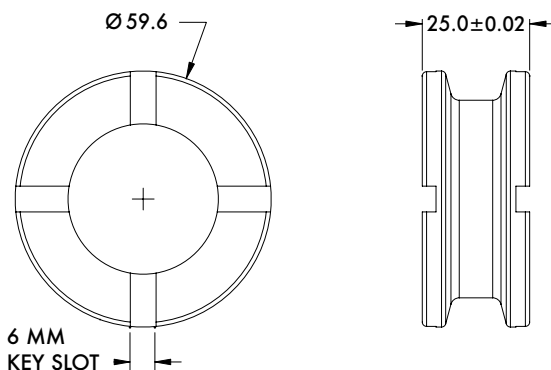

Model Number	Weight
STB0025-NA	.08 kg [.18 lb]

Ø60mm 25mm Engineered Breakaway Boom Spacers

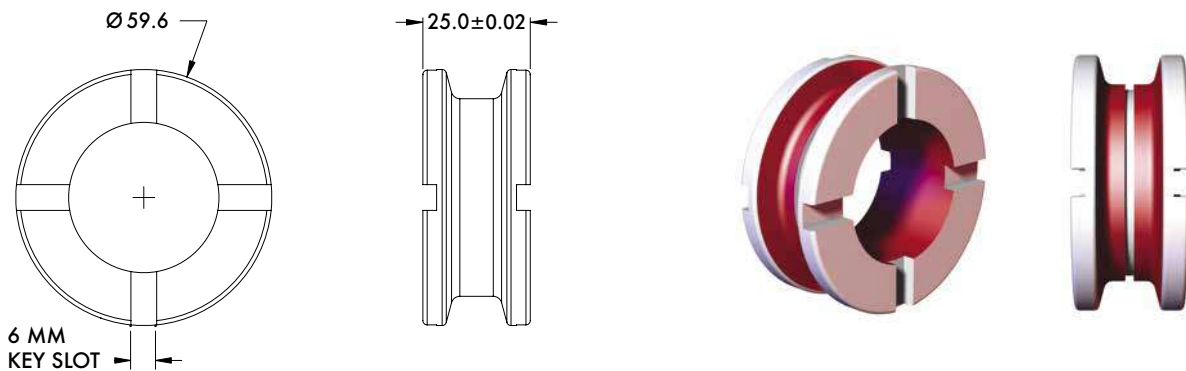

Model Number	Weight
STB0025-BA-800	.08 kg [.18 lb]

This Product is designed to breakaway at 800 N*m [590 ft-lb]

SPIDERGRIP BOOMS

Spidergrip Tooling Components | Dimensions | Technical Specifications



Ø60mm 2-Face 45° Junction

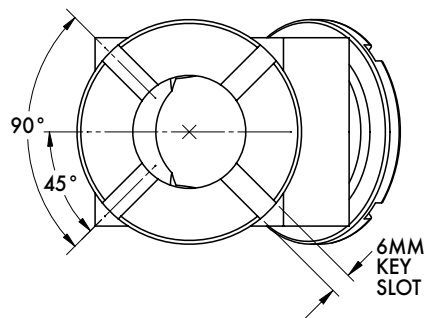
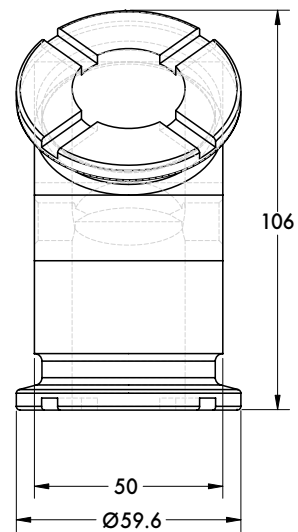
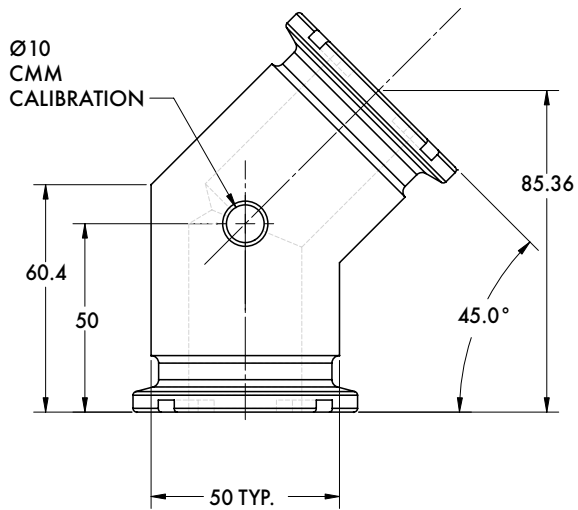
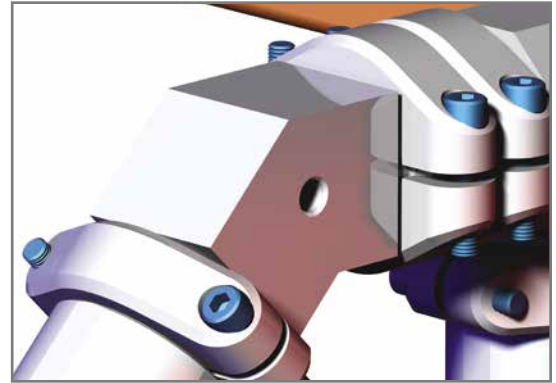
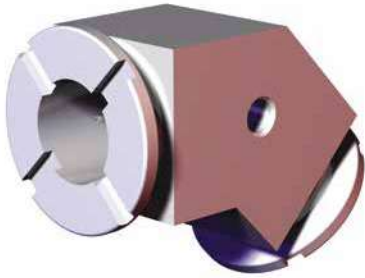

Model Number

Weight

STN0C45-NA

.42 kg [.93 lb]



SPIDERGRIP SPACERS

Spidergrip Tooling Components | Dimensions | Technical Specifications

Ø60mm 2-face 90° Junction

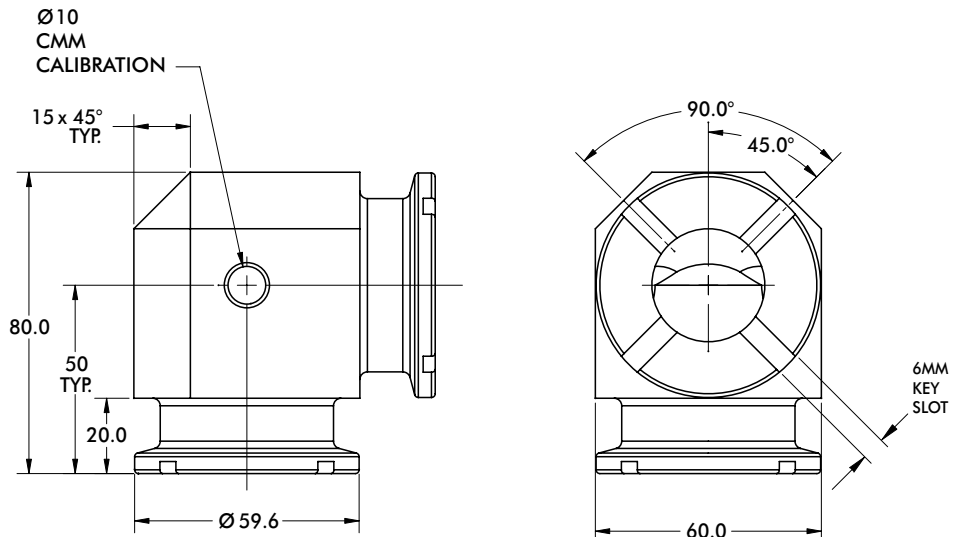
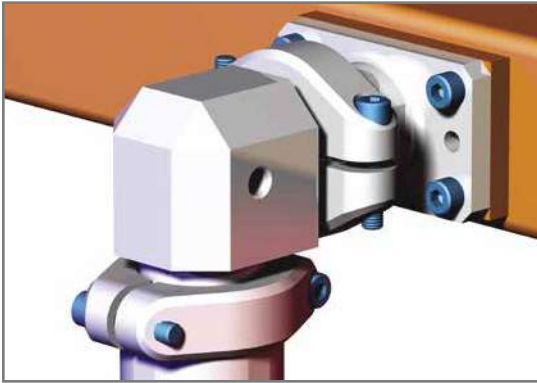

Model Number	Weight
STN0C90-NA	.53 kg [1.16 lb]

SPIDERGRIP JUNCTION COMPONENTS

Spidergrip Tooling Components | Dimensions | Technical Specifications



Ø60mm 3-Face Junction

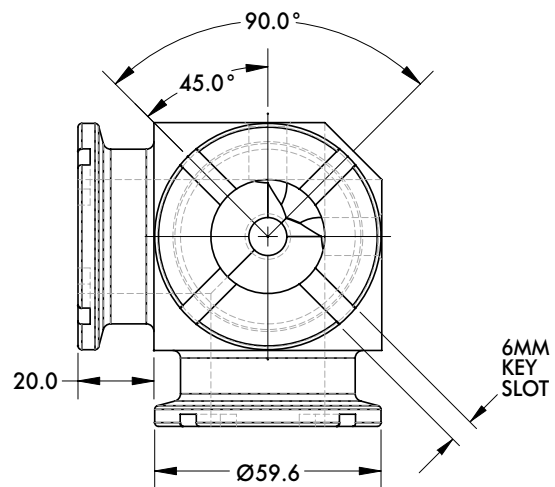
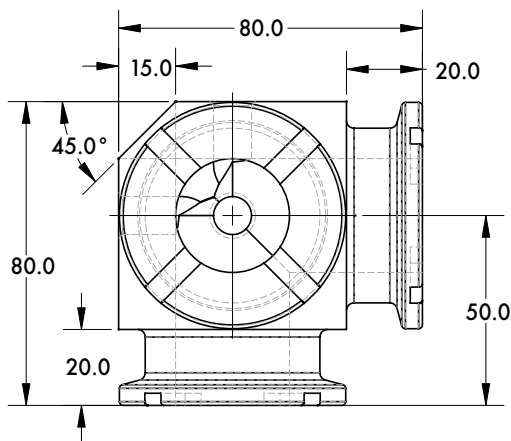
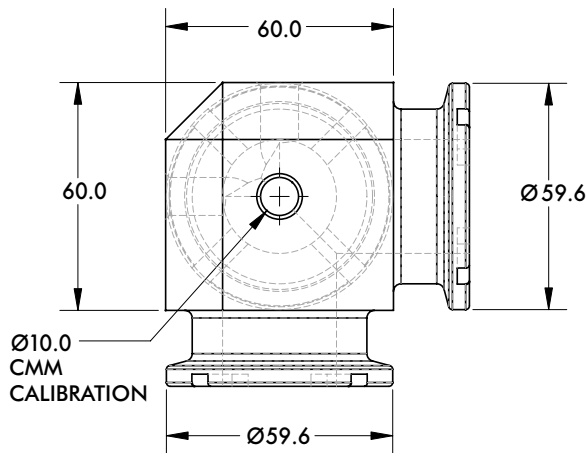
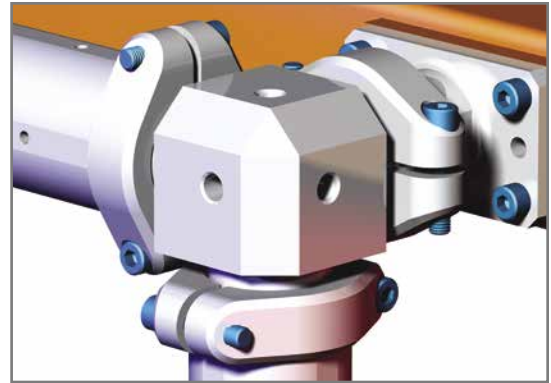
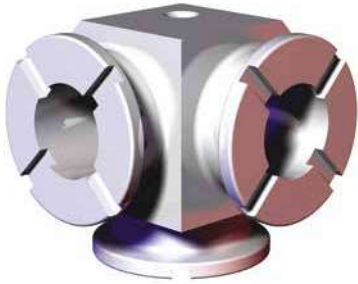

Model Number

Weight

STN0C3F-NA

.58 kg [1.29 lb]



SPIDERGRIP JUNCTION COMPONENTS

Spidergrip Tooling Components | Dimensions | Technical Specifications

Ø60mm 4-Face Junction

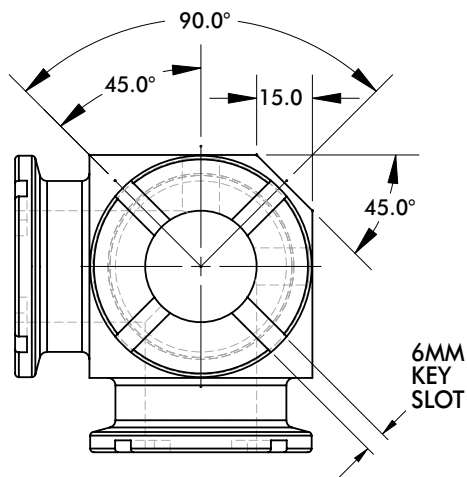
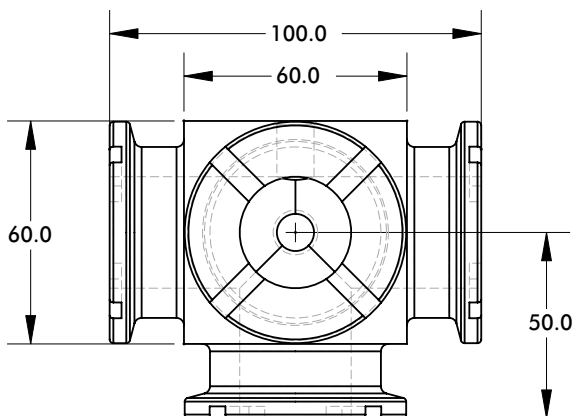
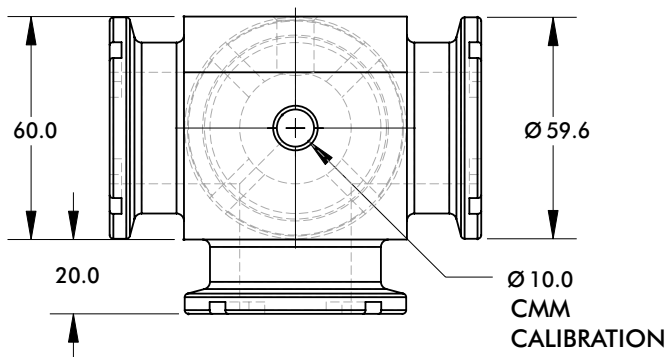
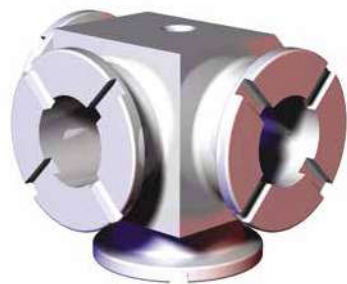
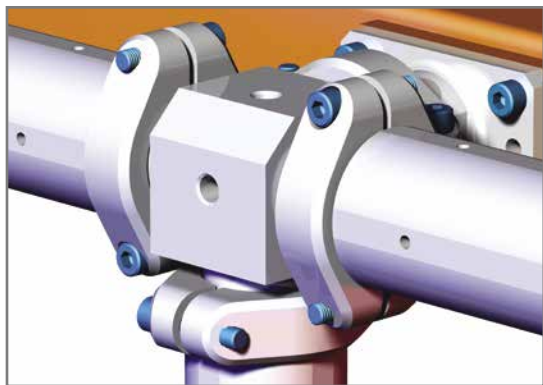

Model Number	Weight
STN0C4F-NA	.65 kg [1.43 lb]

SPIDERGRIP JUNCTION COMPONENTS

Spidergrip Tooling Components | Dimensions | Technical Specifications



Ø60mm 3-Face Junction

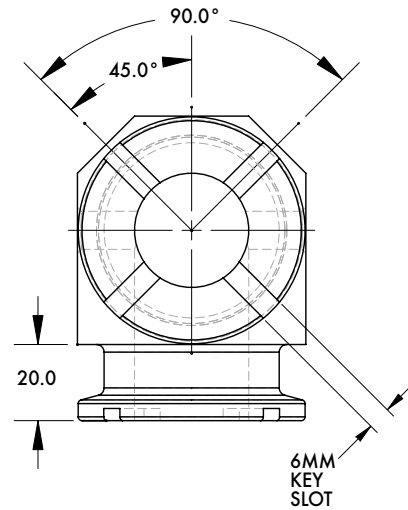
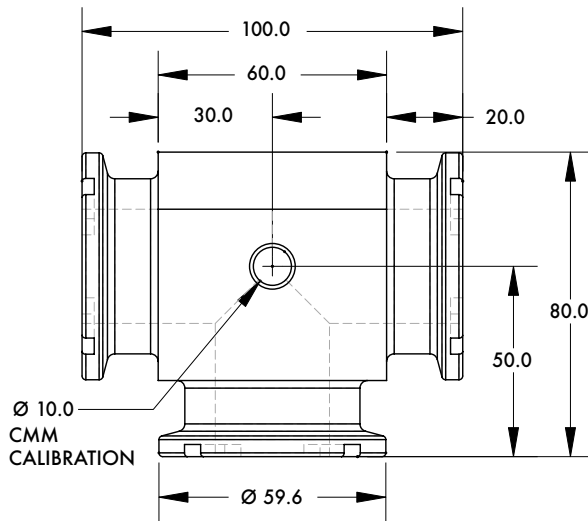
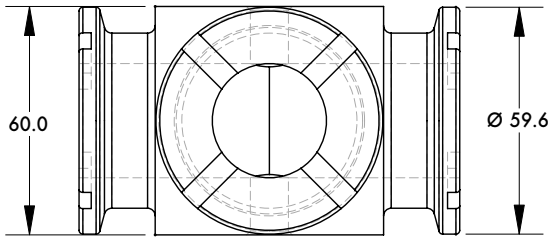
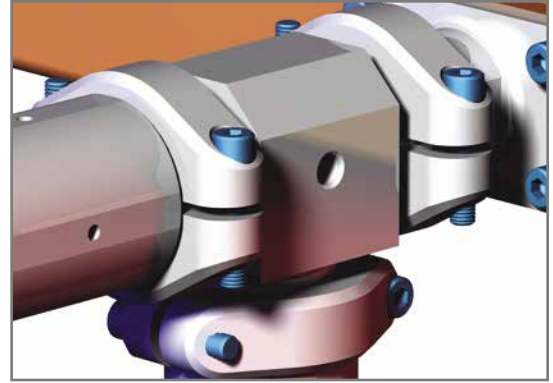
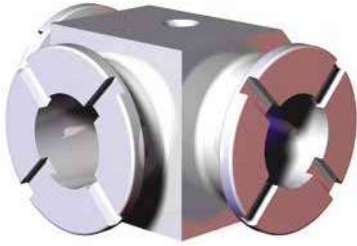

Model Number

Weight

STN0T3F-NA

.60 kg [1.31 lb]



SPIDERGRIP JUNCTION COMPONENTS

Spidergrip Tooling Components | Dimensions | Technical Specifications

Ø60mm 4-Face Junction

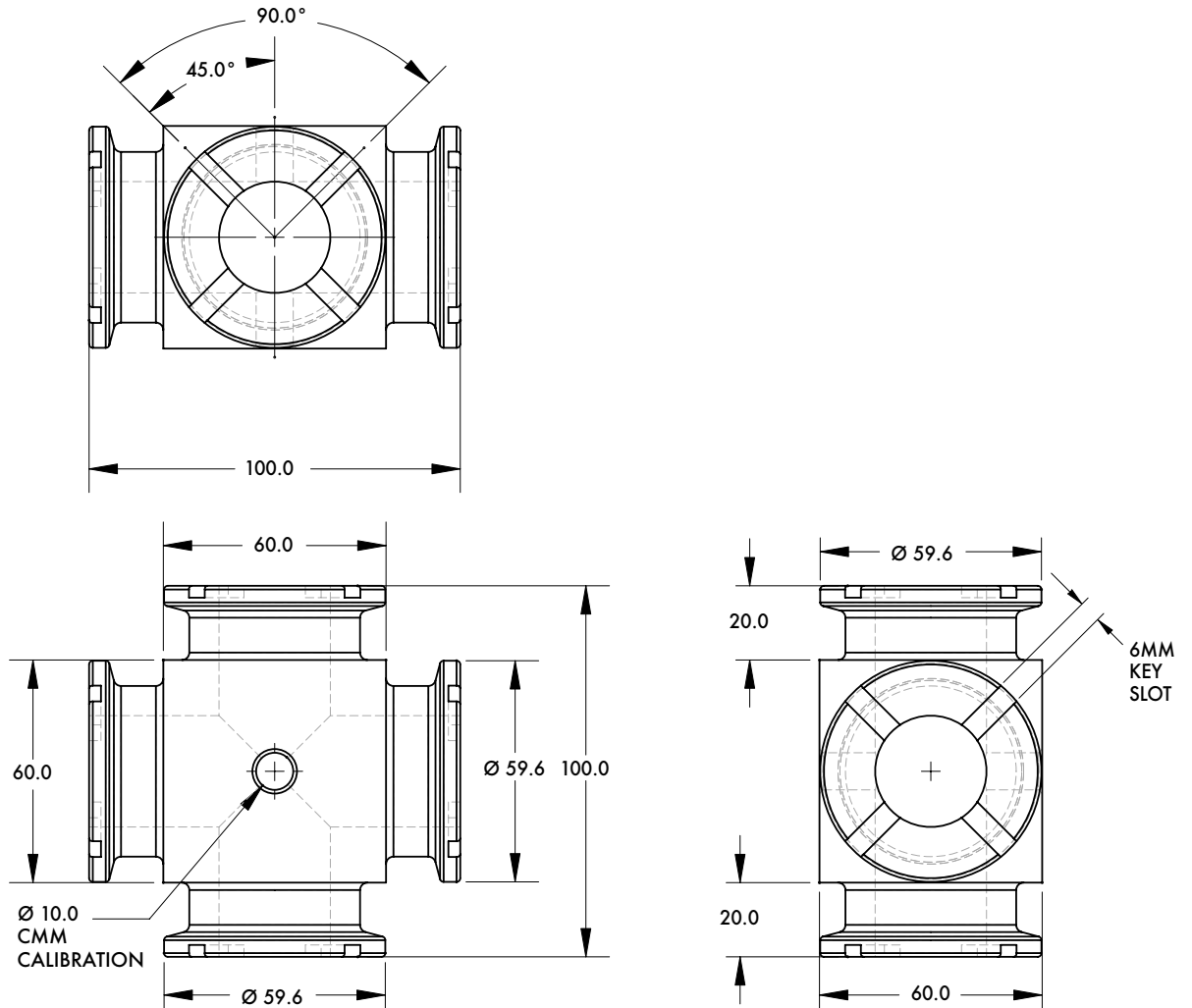
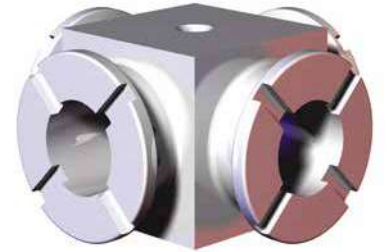

Model Number	Weight
STN0T4F-NA	.67 kg [1.47 lb]

SPIDERGRIP JUNCTION COMPONENTS



Spidergrip Tooling Components | Dimensions | Technical Specifications

Ø60mm 5-Face Junction

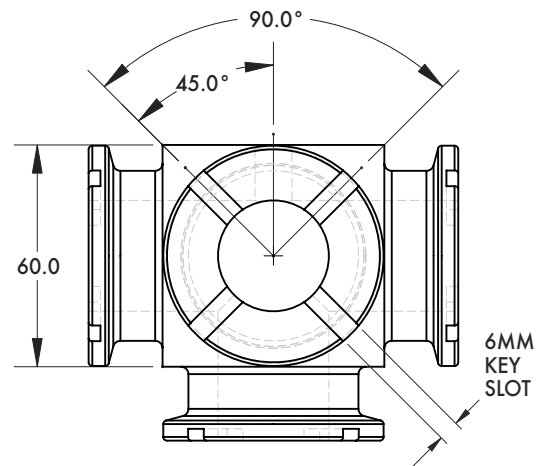
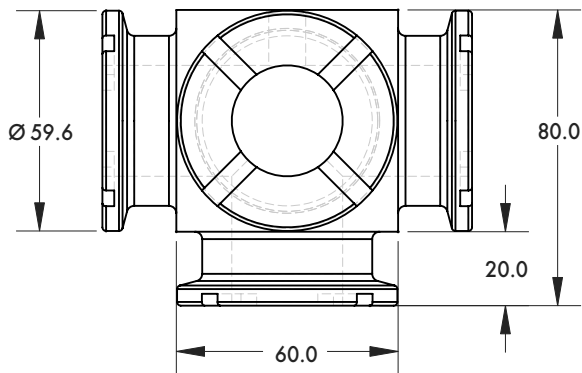
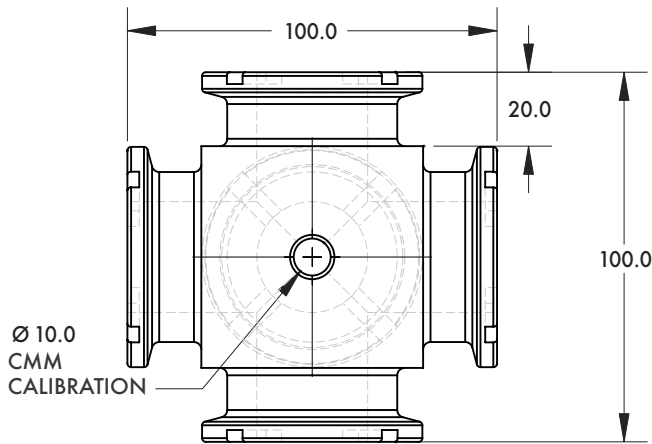
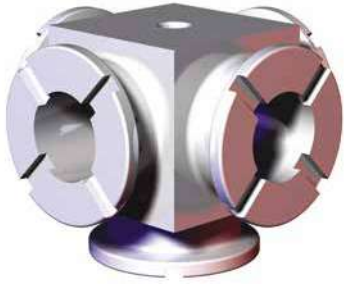

Model Number

STN0T5F-NA

Weight

.71 kg [1.56 lb]



SPIDERGRIP SINGLE END EXTENSIONS

Spidergrip Tooling Components | Dimensions | Technical Specifications

Ø60mm to Ø25mm Single End Extension

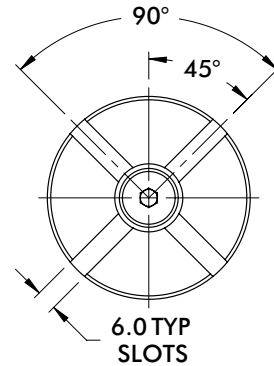
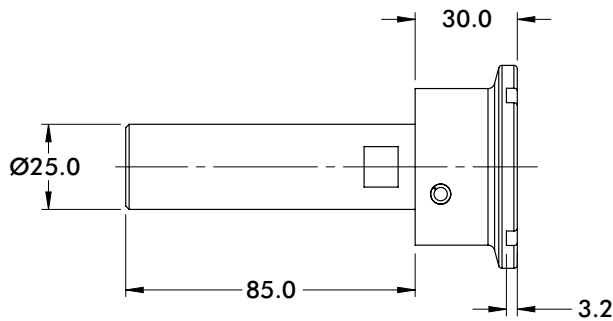
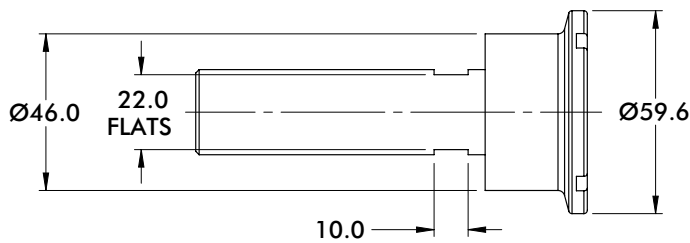
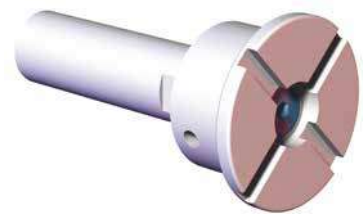
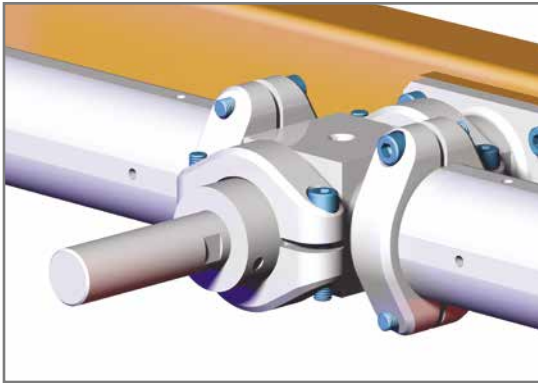

Model Number	Weight
STV0100-NA	.26 kg [.58 lb]

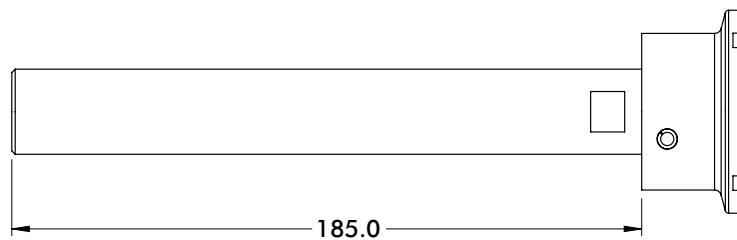

Model Number	Weight
STV0200-NA	.40 kg [.87 lb]

SPIDERGRIP EDGE MOUNTING COMPONENTS



Spidergrip Tooling Components | Dimensions | Technical Specifications

Ø60mm 90° Edge Part with 15mm Center to Face Offset
40mm x 40mm Mounting Pattern

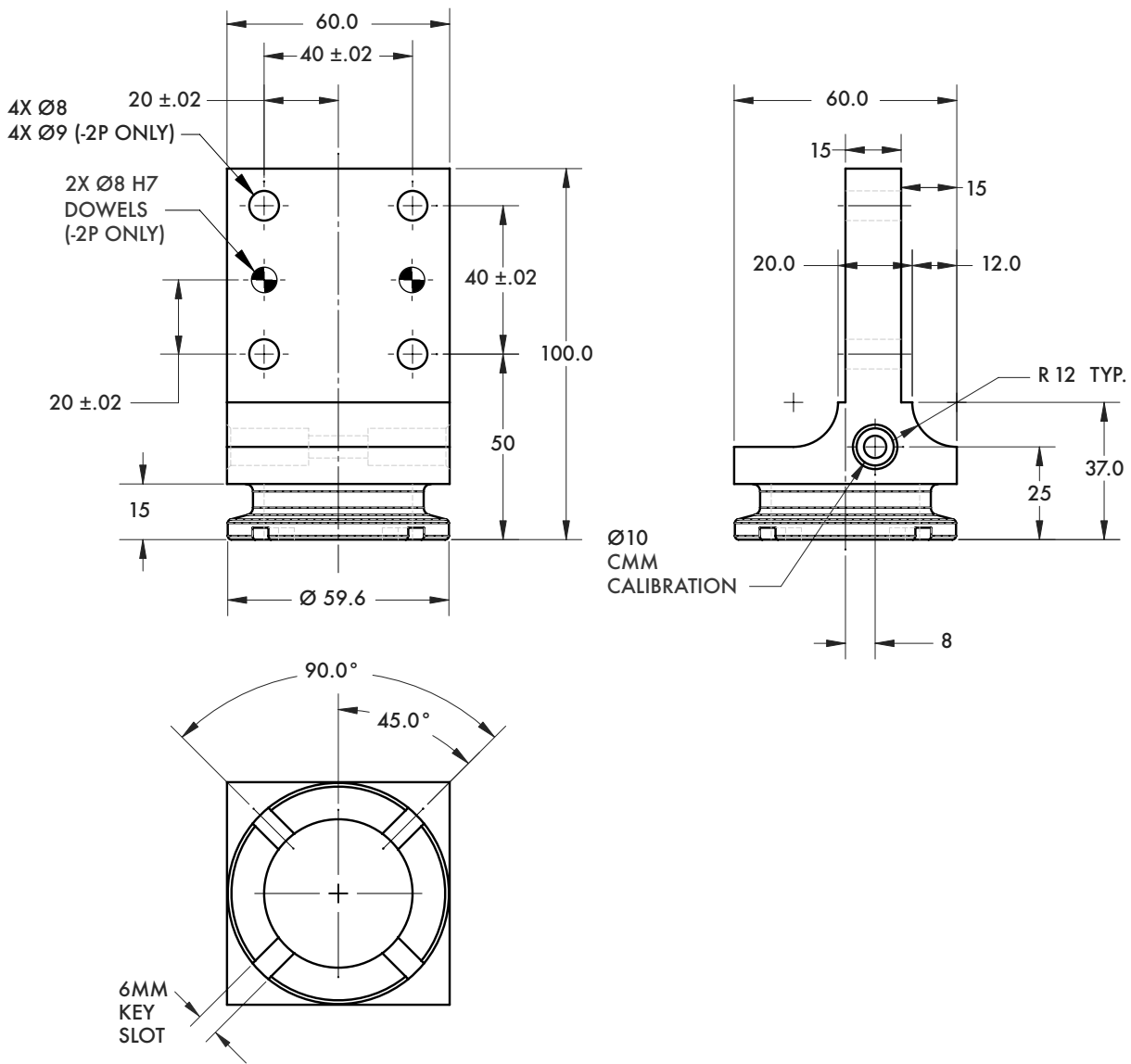
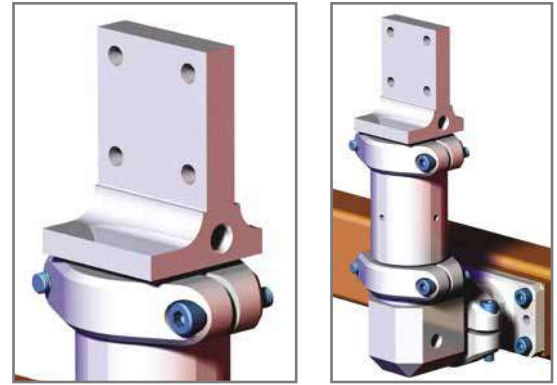
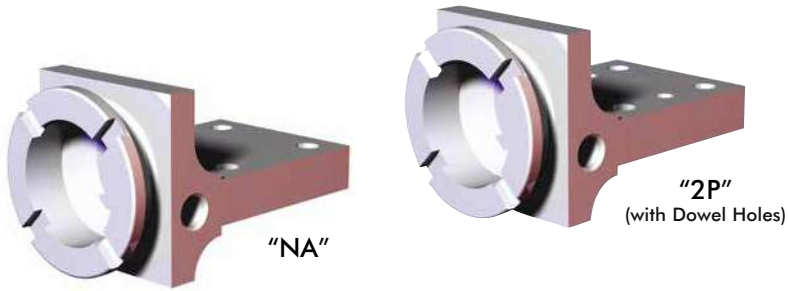

Model Number	Weight
STS0010-NA	.31 kg [.69 lb]
STS0010-NA-2P	



SPIDERGRIP EDGE MOUNTING COMPONENTS

Spidergrip Tooling Components | Dimensions | Technical Specifications



Ø60mm 90° Edge Part with 25mm Center to Face Offset
40mm x 40mm Mounting Pattern

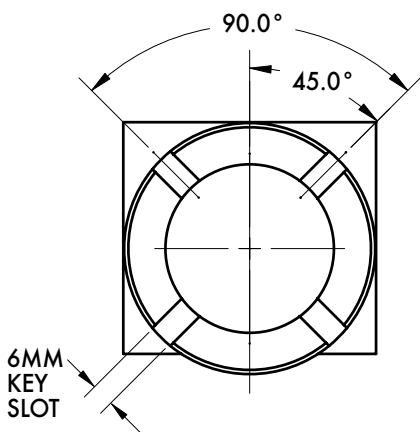
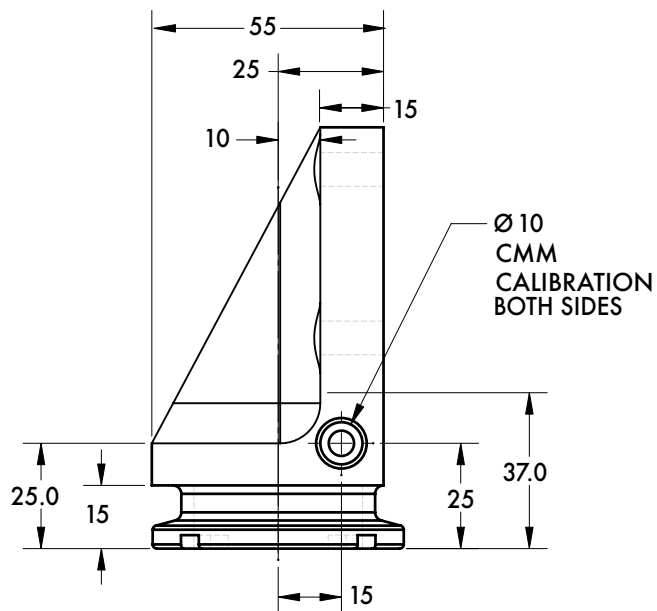
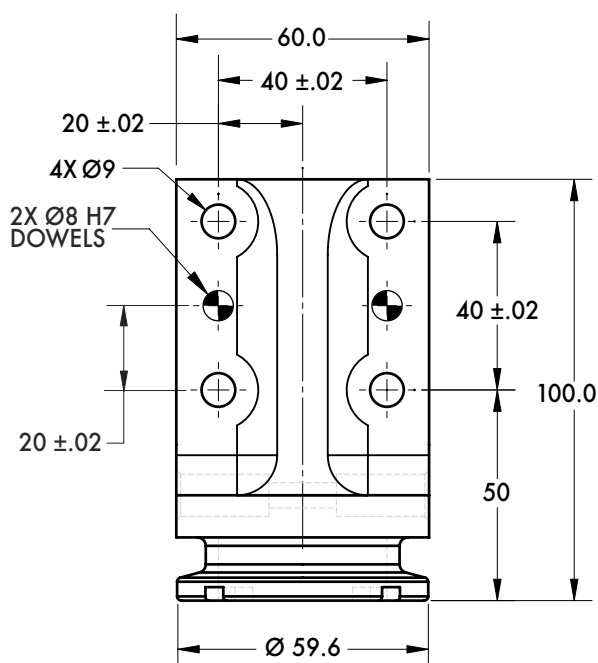
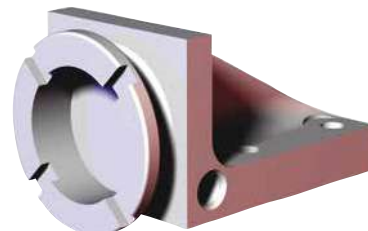

Model Number	Weight
STS0011-NA-2P	.35 kg [.77 lb]

SPIDERGRIP EDGE MOUNTING COMPONENTS



Spidergrip Tooling Components | Dimensions | Technical Specifications

Ø60mm 90° Edge Part with 50mm Center to Face Offset
40mm x 40mm Mounting Pattern

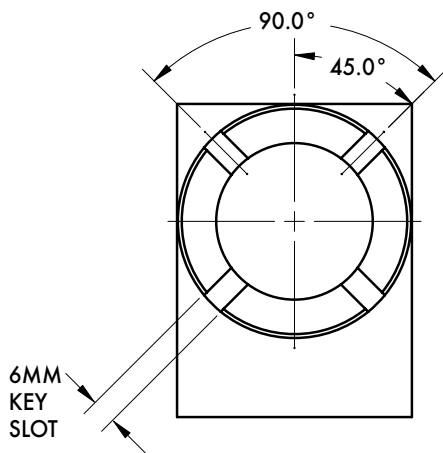
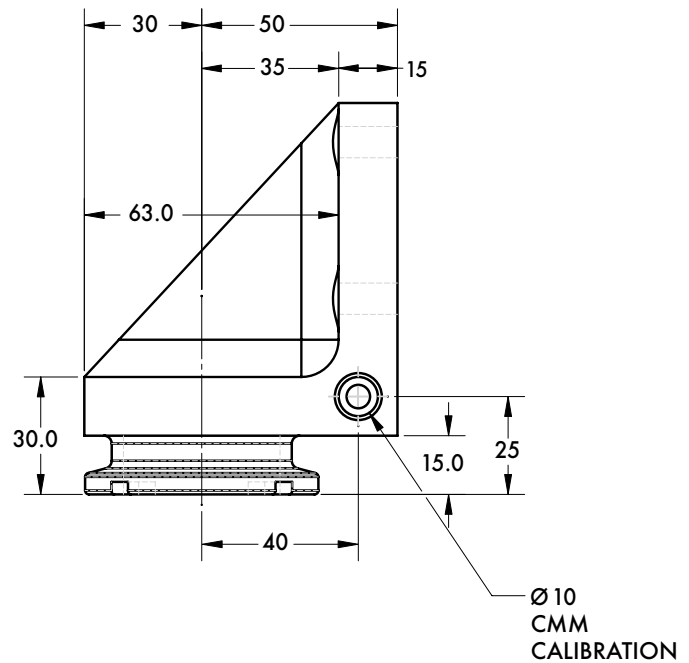
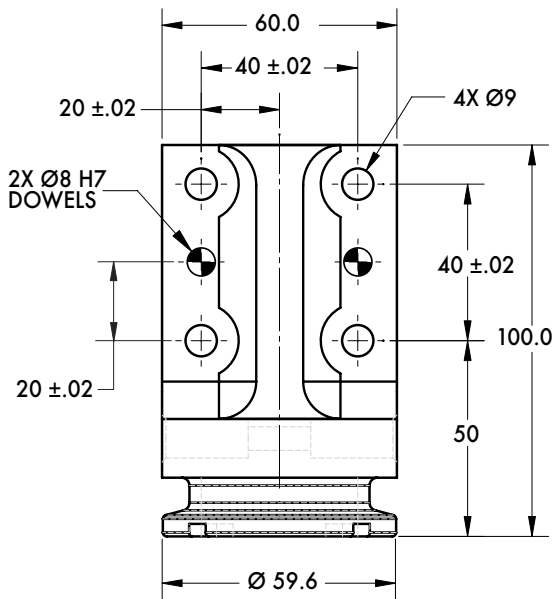
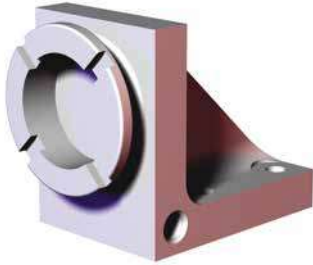

Model Number	Weight
STS0012-NA-2P	.47 kg [1.04 lb]



SPIDERGRIP EDGE MOUNTING COMPONENTS

Spidergrip Tooling Components | Dimensions | Technical Specifications

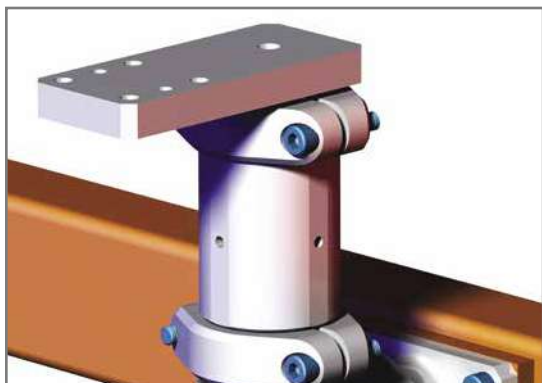

Ø60mm Offset Edge Part with 25mm Face Offset
40mm x 40mm Mounting Pattern

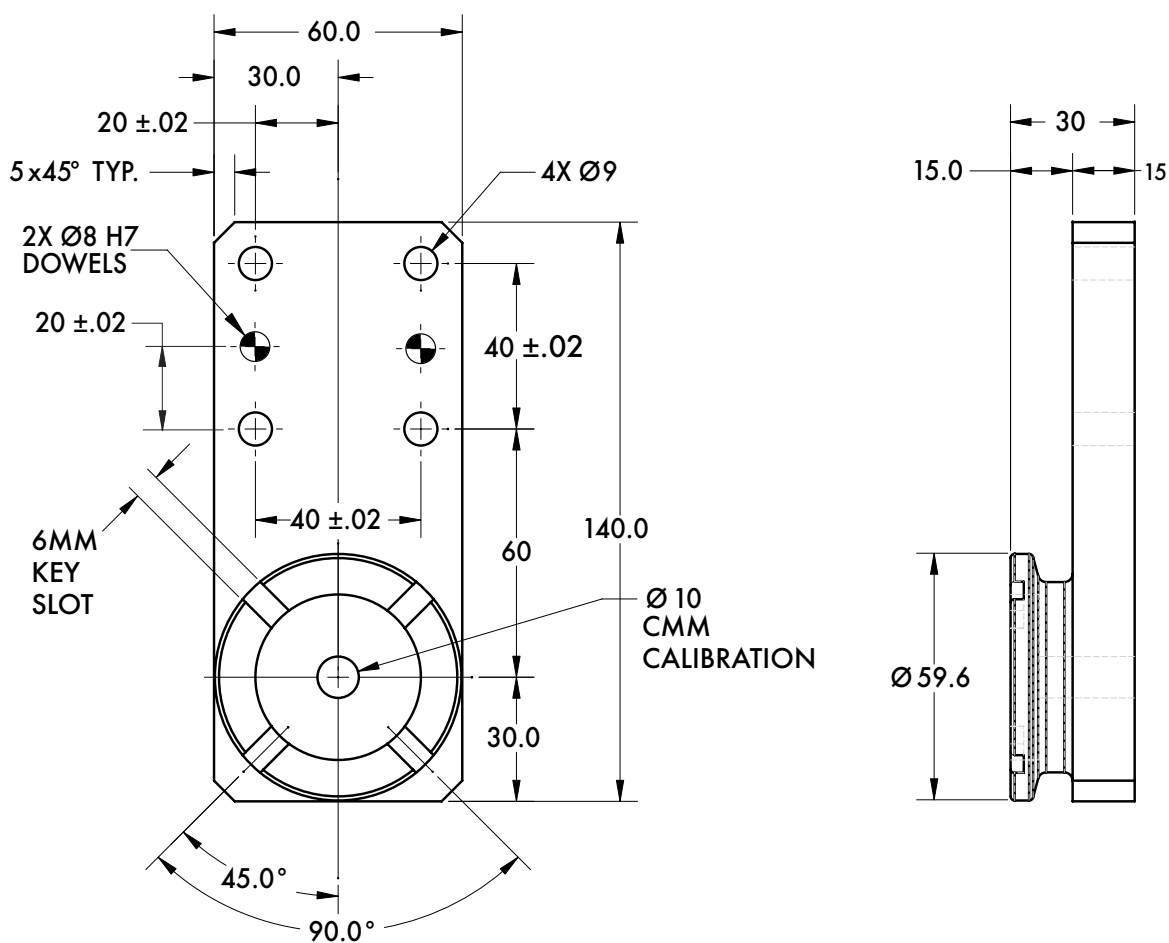

Model Number	Weight
STS0014-NA-2P	.39 kg [.85 lb]

SPIDERGRIP EDGE MOUNTING COMPONENTS



Spidergrip Tooling Components | Dimensions | Technical Specifications

Ø60mm In-line Edge Part with 25mm Face Offset
80mm x 40mm Mounting Pattern

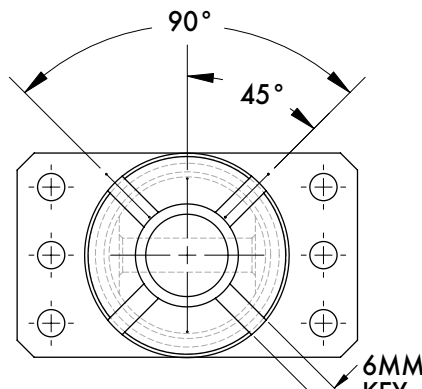
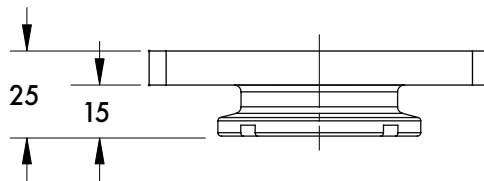
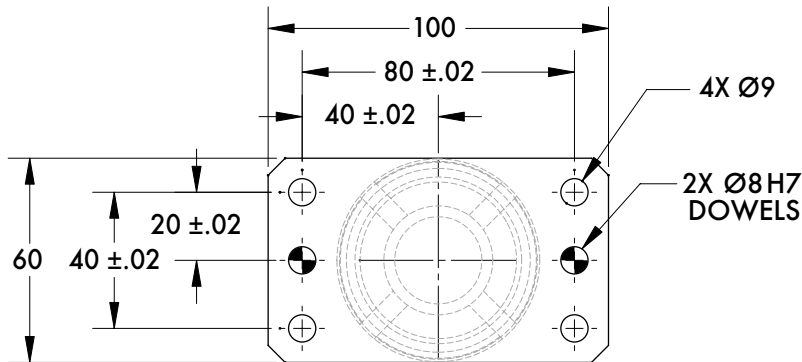
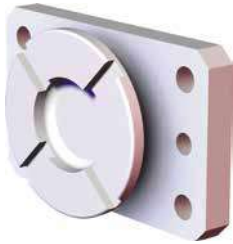

Model Number	Weight
STS0015-NA-2P	.21 kg [.46 lb]



SPIDERGRIP EDGE MOUNTING COMPONENTS

Spidergrip Tooling Components | Dimensions | Technical Specifications

Ø60mm In-line Edge Part with 50mm Face Offset
80mm x 40mm Mounting Pattern

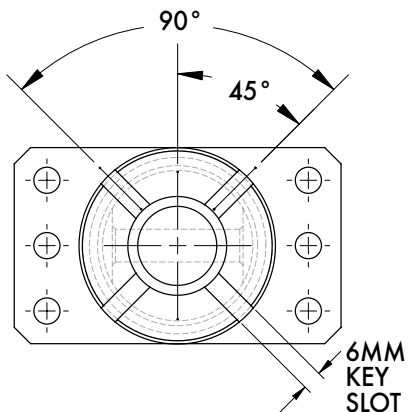
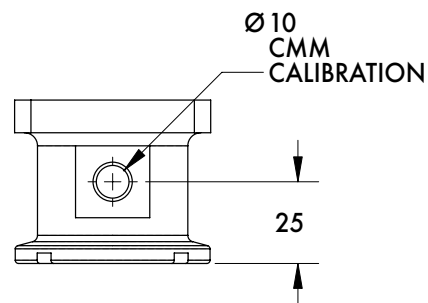
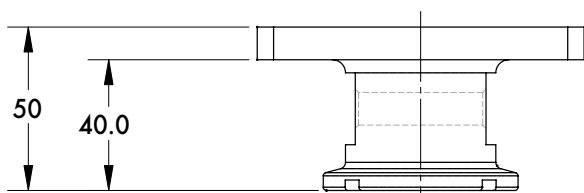
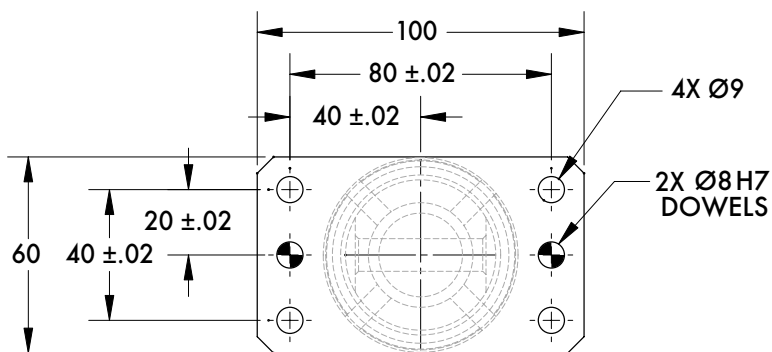
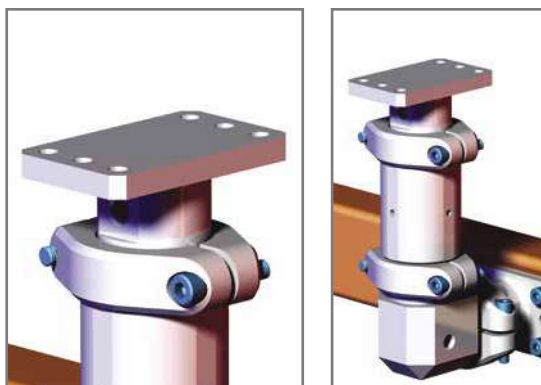

Model Number	Weight
STS0019-NA-2P	.32 kg [.71 lb]

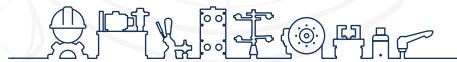

inf @ /CESEHSA.com.mx

