

## Robot Adaptors

01/29/2025



info@cesehsa.com.mx

cesehsa.com.mx

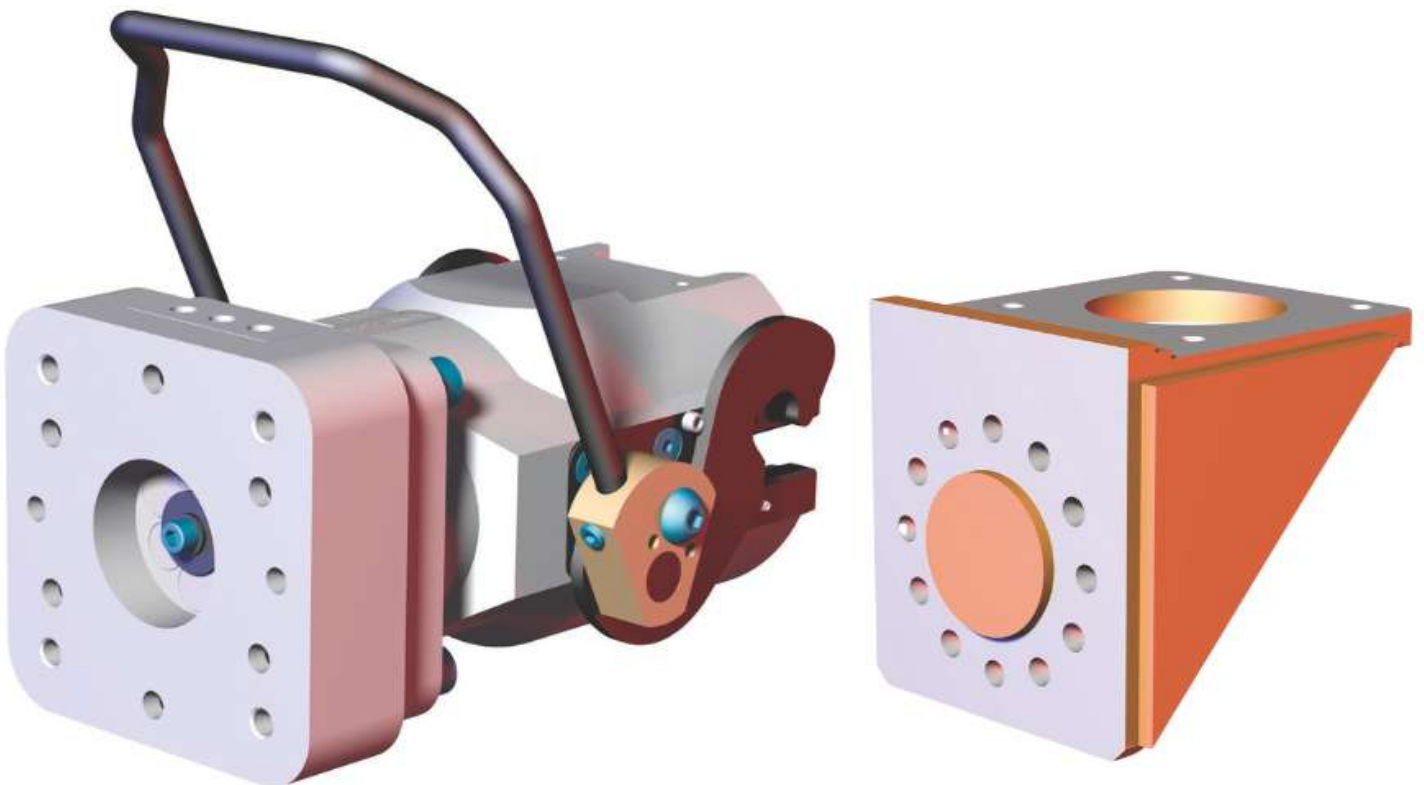

# Robot Adaptors

01/29/2025

This catalog is a custom document and the products included is based on your unique selection from portions of complete catalogs that already exist. Please refer to our full catalogs for more information on products not included in this customized document.

## Table of Contents

Robot Adaptors

EE-ADP-1

## Table of Contents (continued)

# ROBOT ADAPTER MOUNTS

## Table of Contents



Adaptor Mount Assemblies and Components ..... 3-28

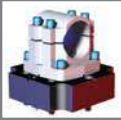

Mid-Mount Flanges ..... 29



Tooling Mounting Blocks ..... 38

# ROBOT ADAPTER MOUNTS

Robot Automation Adaptors | Selection Guide - Manual Tool Changers RDN-25 Series

**STYLE 1 (ACMX58)**

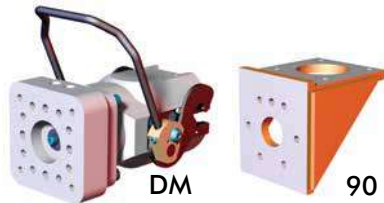

**STYLE 2 (FA500)**

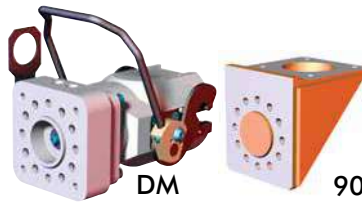

**STYLE 3 (KW150)**

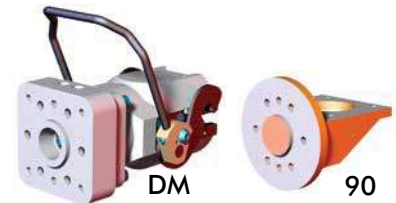

**STYLE 4 (FA900)**

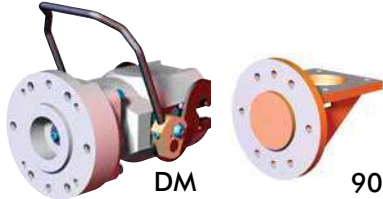

**STYLE 5 (KA760)**

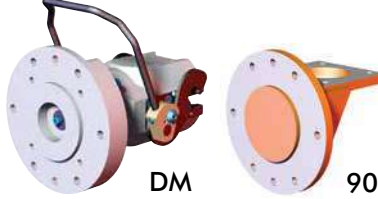

**STYLE 6 (MMNY300)**

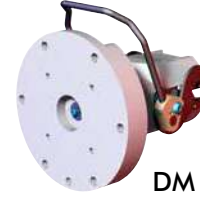

**STYLE 7 (FA430I)**

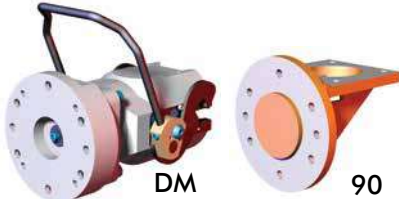

**STYLE 8 (FA420)**

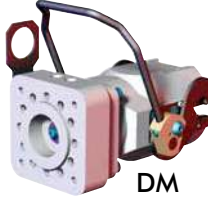

**STYLE 9 (ABB44)**

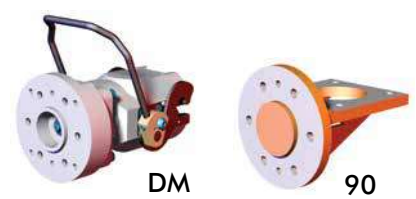

**STYLE 10 (KWZ165)**

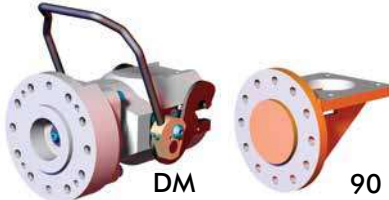

**STYLE 11 (KWUT120)**



**STYLE 12 (FA710)**

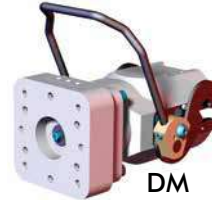

**STYLE 14 (MMK100)**



**STYLE 15 (KA660)**

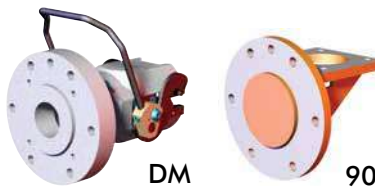

**STYLE 16 (FA2000)**



**STYLE 18 (MMHP165-125)**

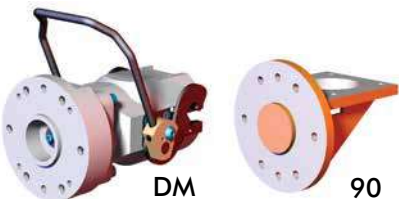

**STYLE 19 (MMHP165-92)**

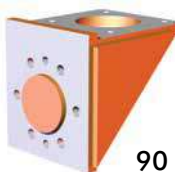

**STYLE 21 (EOAMC30)**

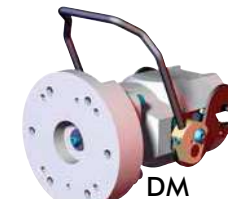

**STYLE 22 (FA900-SSM)**



**STYLE 23 (MD350)**

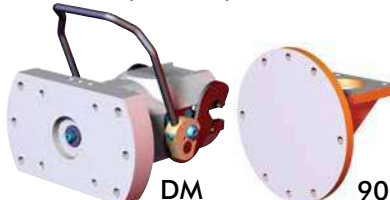

**STYLE 24 (SA000)**



# ROBOT ADAPTER MOUNTS

Robot Automation Adaptors | Selection Guide - Manual Tool Changers RDN-25 Series

250 SERIES ROBOT ADAPTOR SELECTION GUIDE										
ADAPTOR MOUNTS		MOUNTING PATTERN			DOWELS			PILOT		DWG PAGE
STYLE (MODEL)	TYPE AVAIL.	BOLT CIRCLE	BOLT SIZE	BOLTS QTY	BOLT CIRCLE	DWL SIZE	DWL QTY	DIAMETER (Ø)	DEPTH	
STYLE 1 (ACMX58)	DM/90	Ø90mm [Ø3.54"]	M8	8	Ø80mm [Ø3.15"]	10mm	4	N/A	N/A	4
STYLE 2 (FA500)	DM/90	Ø90mm [Ø3.54"]	M10	8	Ø90mm [Ø3.54"]	10mm	4	Ø59.5mm [Ø2.34"]	4.8 [.19]	5
STYLE 3 (KW150)	DM/90	Ø92mm [Ø3.62"]	M10	6	Ø92mm [Ø3.62"]	9mm	2	Ø54mm [Ø2.13"]	6.4 [.25]	6
STYLE 4 (FA900)	DM/90	Ø125mm [Ø4.92"]	M10	6	Ø125mm [Ø4.92"]	10mm	2	Ø79.5mm [Ø3.13"]	6.4 [.25]	7
STYLE 5 (KA760)	DM/90	Ø160mm [Ø6.30"]	M10	6	Ø160mm [Ø6.30"]	10mm	2	Ø99.9mm [Ø3.94"]	6.4 [.25]	8
STYLE 6 (MMNY300)	DM	Ø200mm [Ø7.87"]	M12	6	Ø200mm [Ø7.87"]	12mm	1	N/A	N/A	9
STYLE 7 (FA430I)	DM/90	Ø125mm [Ø4.92"]	M10	6	Ø125mm [Ø4.92"]	10mm	2	Ø79.5mm [Ø3.13"]	6.4 [.25]	10
STYLE 8 (FA420)	DM	Ø92mm [Ø3.62"]	M10	8	Ø92mm [Ø3.62"]	10mm	4	Ø79.5mm [Ø3.13"]	4.8 [.19]	11
STYLE 9 (ABB44)	DM/90	Ø100mm [Ø3.94"]	M10	6	Ø100mm [Ø3.94"]	8mm	2	Ø61.9mm [Ø2.44"]	6.4 [.25]	12
STYLE 10 (KWZ165)	DM/90	Ø125mm [Ø4.92"]	M10	10	Ø125mm [Ø4.92"]	10mm	2	Ø79.5mm [Ø3.13"]	6.4 [.25]	13
STYLE 11 (KWUT120)	90	Ø120mm [Ø4.72"]	M8	8	Ø120mm [Ø4.92"]	8mm	2	N/A	N/A	14
STYLE 12 (FA710)	DM	Ø100mm [Ø3.94"]	M8	6	Ø100mm [Ø3.94"]	8mm	2	N/A	N/A	15
STYLE 14 (MMK100)	90	Ø125mm [Ø4.92"]	M10	6	Ø125mm [Ø4.92"]	10mm	2	Ø61mm [Ø2.40"]	6.4 [.25]	16
STYLE 15 (KA660)	DM/90	Ø160mm [Ø6.30"]	M12	6	Ø160mm [Ø6.30"]	12mm	1	Ø99mm [Ø3.90"]	6.4 [.25]	17
STYLE 16 (FA2000)	DM	Ø125mm [Ø4.92"]	M10	10	Ø125mm [Ø4.92"]	10mm	2	Ø79.5mm [Ø3.13"]	6.4 [.25]	18
STYLE 18 (MMHP165)	DM/90	Ø125mm [Ø4.92"]	M10	6	Ø125mm [Ø4.92"]	10mm	2	Ø62.5mm [Ø2.46"]	6.4 [.25]	19
STYLE 19 (MMHP165)	90	Ø92mm [Ø3.62"]	M10	6	Ø125mm [Ø4.92"]	9mm	2	Ø62.5mm [Ø2.46"]	6.4 [.25]	20
STYLE 21 (EOAMC30)	DM	Ø127mm [Ø5.00"]	3/8-16	6	Ø108mm [Ø4.25"]	.25"(in)	2	N/A	N/A	21
STYLE 22 (FA900-SSM)	DM	Ø125mm [Ø4.92"]	M10	6	Ø125mm [Ø4.92"]	10mm	2	Ø79.5mm [Ø3.13"]	4.8 [.19]	21
STYLE 23 (MD350)	DM/90	Ø187.3mm [Ø7.38"]	3/8-16	4	Ø187.3mm [Ø7.38"]	3/8	2	N/A	N/A	22
STYLE 24 (SA000)	DM	Ø69.5mm [Ø2.74"]	M10	4	N/A	N/A	N/A	N/A	N/A	23

### Style 01 - **ACMX58** 90° Robot Adaptor (Ø90mm Bolt Circle/Ø80mm Dowel Circle)

**Models Supported:**  
ACMA X58

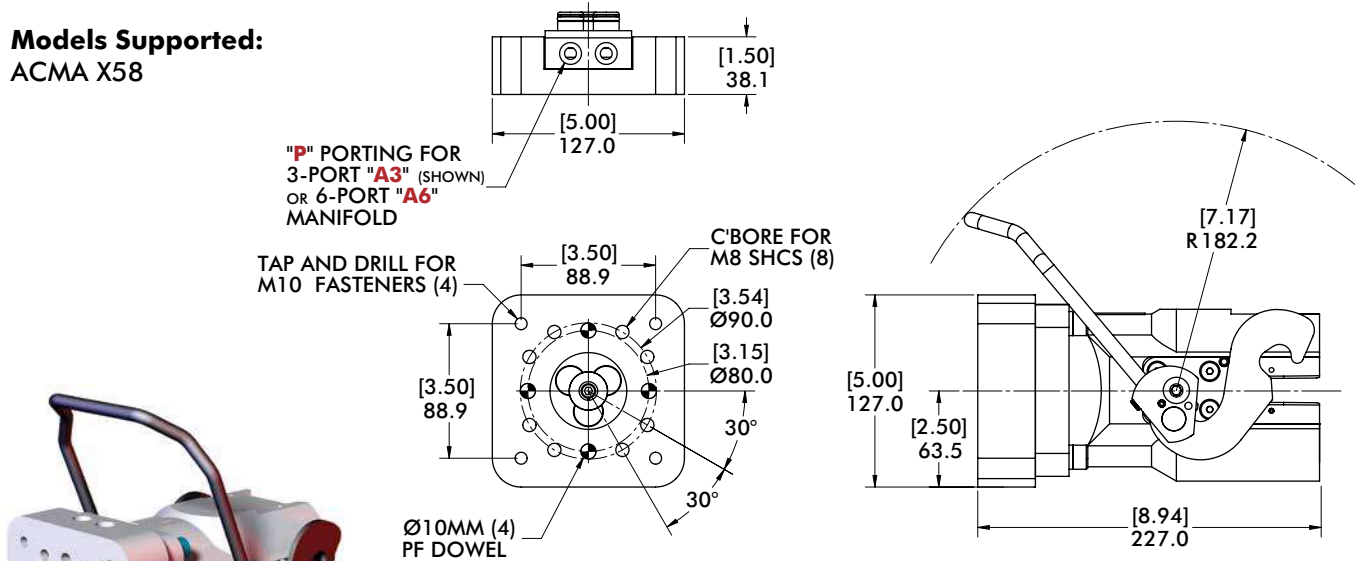

MODEL NUMBER	PORTING	# OF PORTS	WEIGHT
<b>CPI-ACMX58-DM-RD25-A3</b>	3/8 NPT	3 (2/1)	.75 kg [1.66 lb]
<b>CPI-ACMX58-DM-RD25-A6</b>	1/8 NPT	6 (3/3)	.79 kg [1.74 lb]

### Style 01 - **ACMX58** 90° Robot Adaptor (Ø90mm Bolt Circle/Ø80mm Dowel Circle)

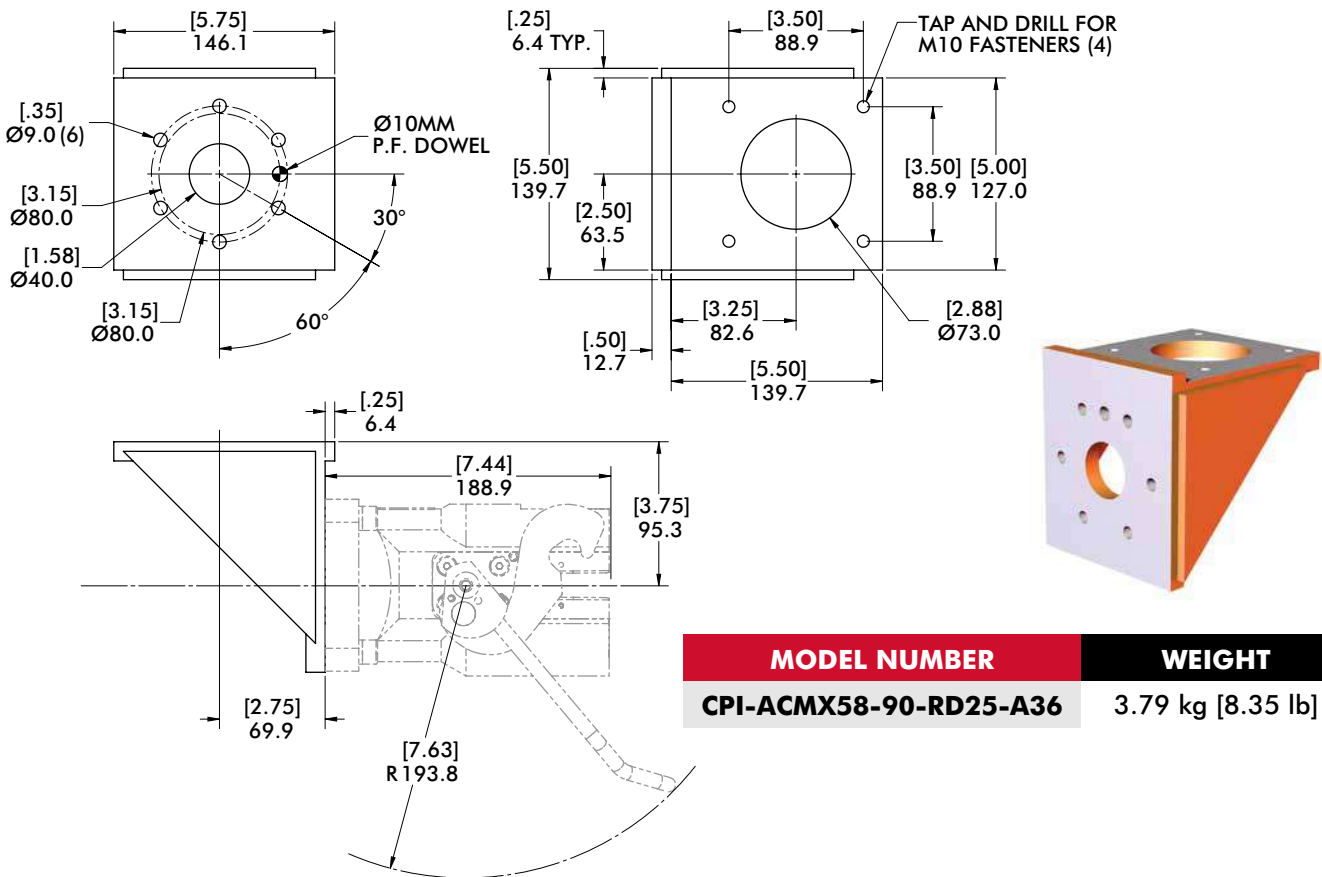

MODEL NUMBER	WEIGHT
<b>CPI-ACMX58-90-RD25-A36</b>	3.79 kg [8.35 lb]

# FA500

## Robot Automation Adaptors | Dimensions

### Style 02 - FA500 Direct Mount Adaptor (Ø90mm Bolt Circle)

#### Models Supported:

- FANUC M-400
- FANUC M-500
- FANUC S-420 (WITH FANUC FLANGE)

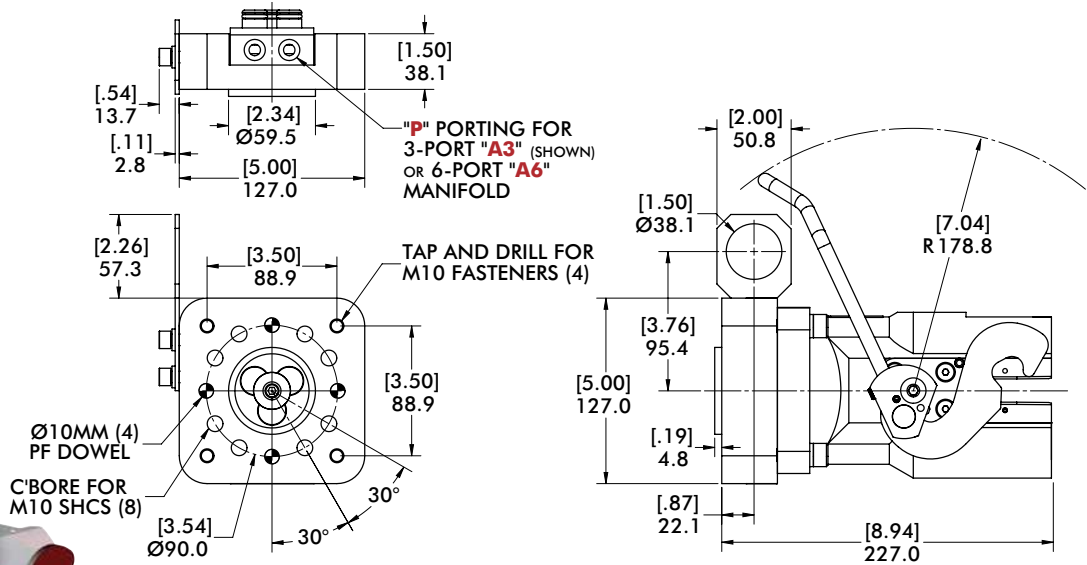
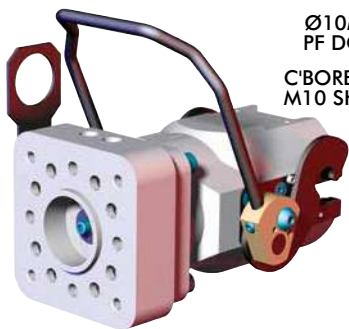

MODEL NUMBER	PORTING	# OF PORTS	WEIGHT
CPI-FA500-DM-RD25-A3	3/8 NPT	3 (2/1)	1.46 kg [3.21 lb]
CPI-FA500-DM-RD25-A6	1/8 NPT	6 (3/3)	1.50 kg [3.30 lb]

### Style 02 - FA500 90° Robot Adaptor (Ø90mm Bolt Circle)

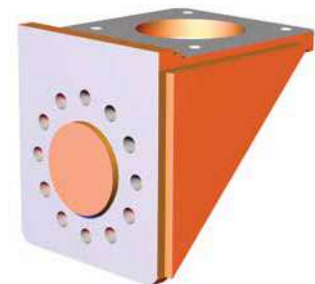
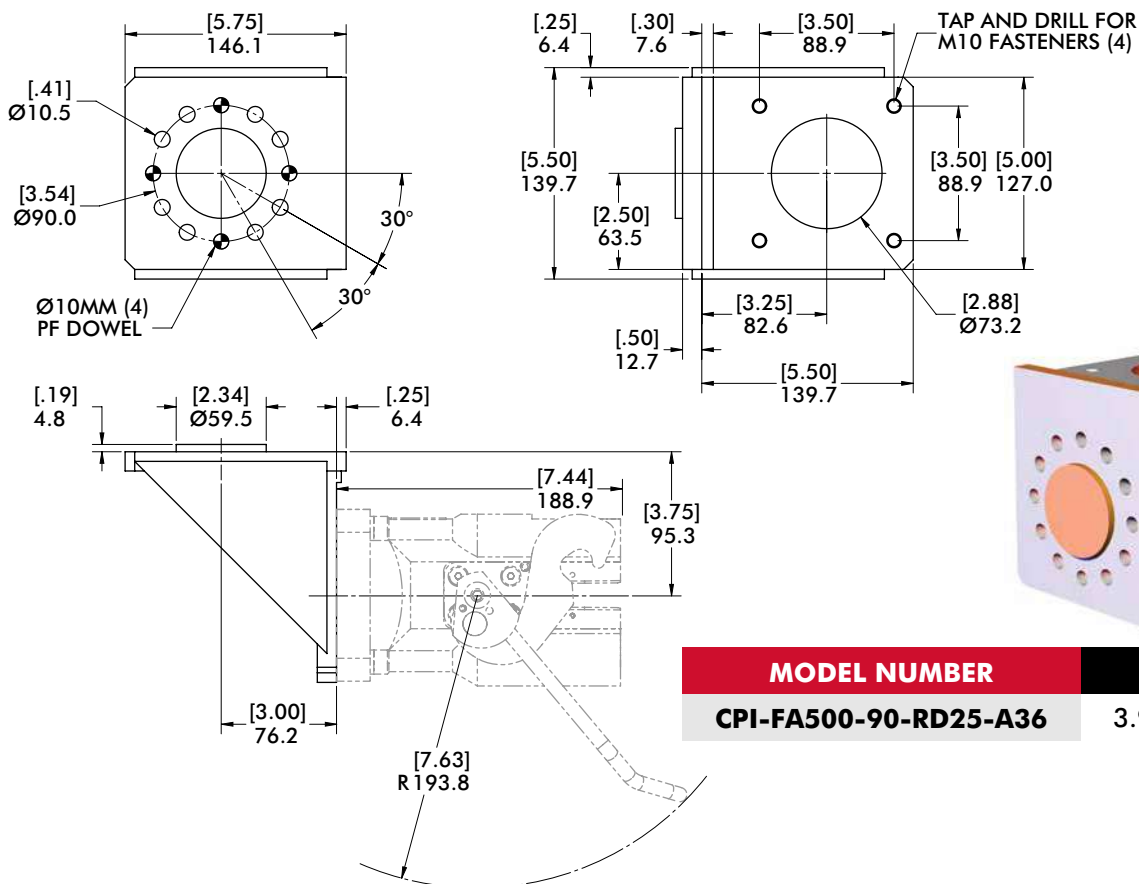

MODEL NUMBER	WEIGHT
CPI-FA500-90-RD25-A36	3.98 kg [8.77 lb]



### Style 03 - KW150 90° Robot Adaptor (Ø92mm Bolt Circle)

#### Models Supported:

KAWASAKI UX100  
KAWASAKI UX120  
KAWASAKI UX150

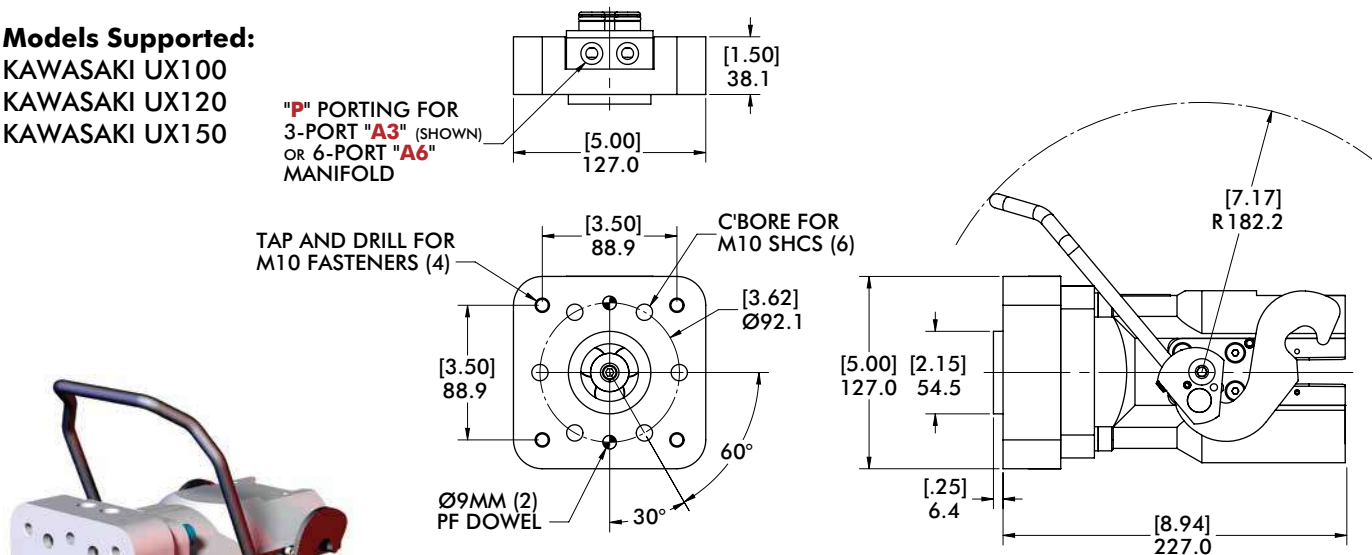

MODEL NUMBER	PORTING	# OF PORTS	WEIGHT
CPI-KW150-DM-RD25-A3	3/8 NPT	3 (2/1)	1.45 kg [3.19 lb]
CPI-KW150-DM-RD25-A6	1/8 NPT	6 (3/3)	1.49 kg [3.28 lb]

### Style 03 - KW150 90° Robot Adaptor (Ø92mm Bolt Circle)

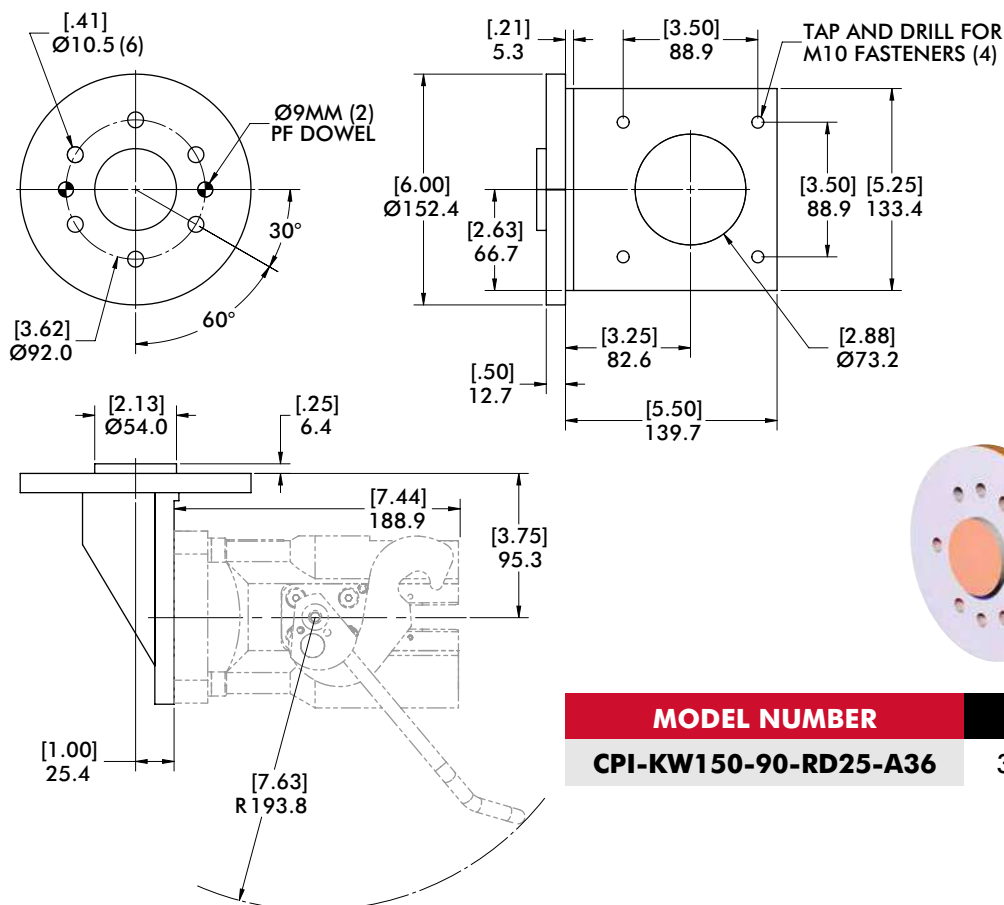

MODEL NUMBER	WEIGHT
CPI-KW150-90-RD25-A36	3.63 kg [8.01 lb]

# FA900

## Robot Automation Adaptors | Dimensions

### Style 04 - FA900 Direct Mount Adaptor (Ø125mm Bolt Circle)

#### Models Supported:

ABB IRB 60(00)  
 ABB IRB 64(00)  
 FANUC R-2000I(6-BOLT)  
 FANUC M-410  
 FANUC S-900  
 MOTOMAN SP100X

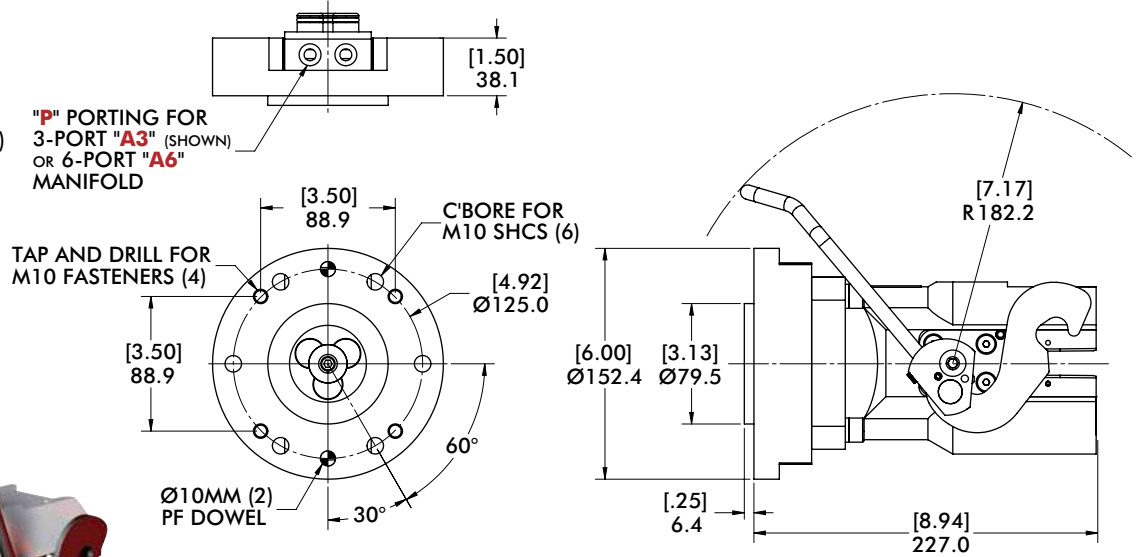
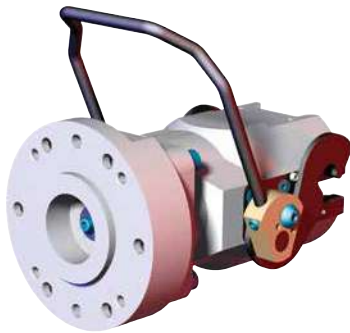

MODEL NUMBER	PORTING	# OF PORTS	WEIGHT
CPI-FA900-DM-RD25-A3	3/8 NPT	3 (2/1)	1.58 kg [3.48 lb]
CPI-FA900-DM-RD25-A6	1/8 NPT	6 (3/3)	1.62 kg [3.57 lb]

### Style 04 - FA900 90° Robot Adaptor (Ø125mm Bolt Circle)

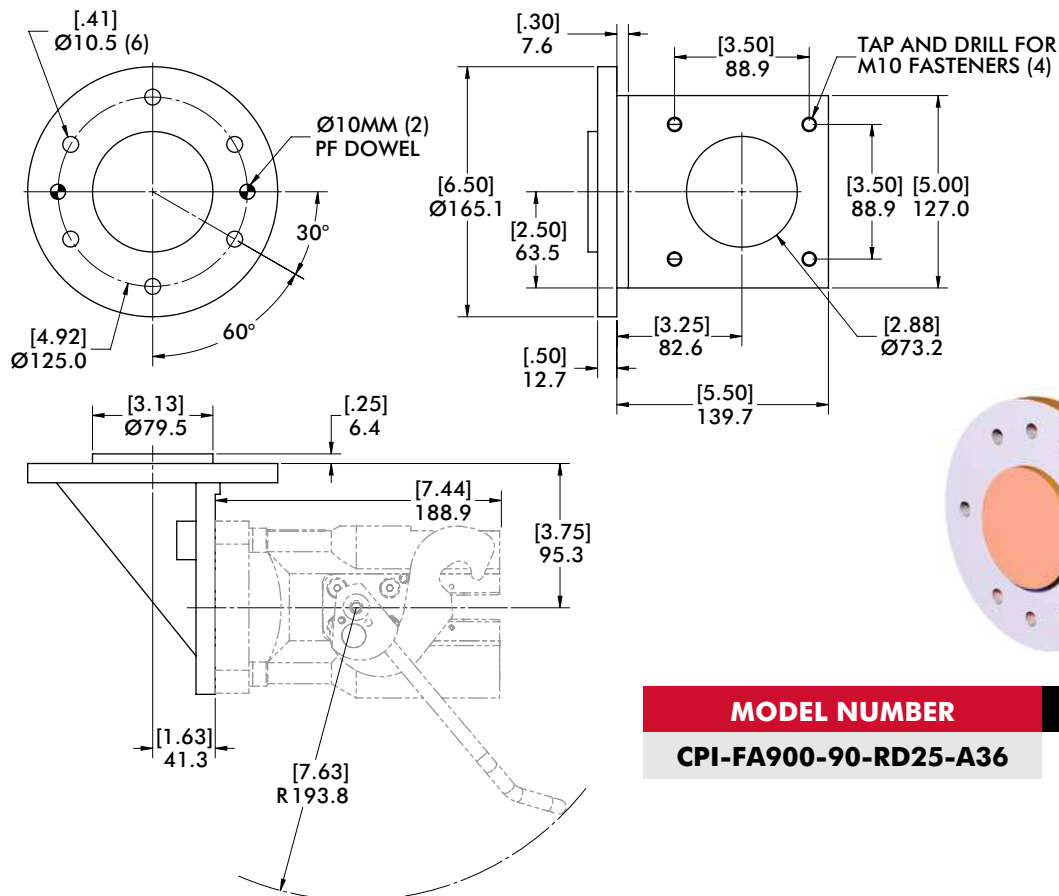

MODEL NUMBER	WEIGHT
CPI-FA900-90-RD25-A36	4.13 kg [9.12 lb]

### Style 05 - **KA760** Direct Mount Adaptor (Ø160mm Bolt Circle)

#### Models Supported:

KUKA IW 125  
 KUKA PL 150  
 KUKA IW 150  
 KUKA PL 125  
 KUKA KR 125  
 KUKA ZH 125  
 KUKA IR 760  
 KUKA ZH 150

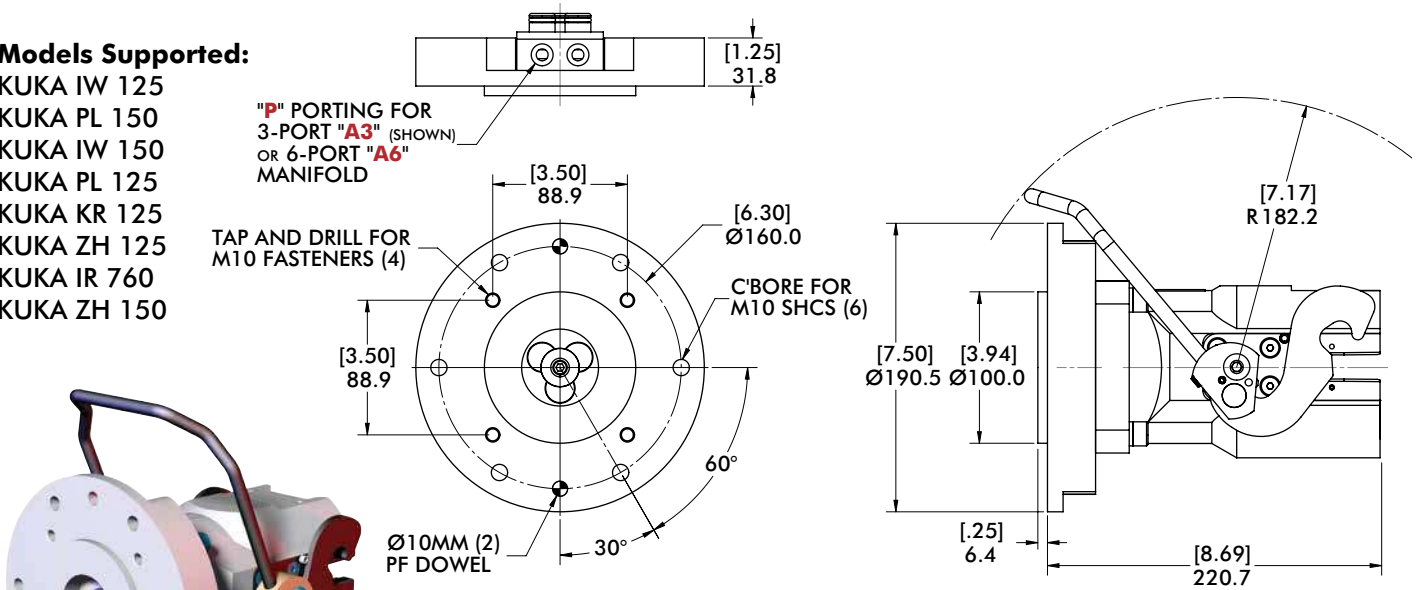

MODEL NUMBER	PORTING	# OF PORTS	WEIGHT
<b>CPI-KA760-DM-RD25-A3</b>	3/8 NPT	3 (2/1)	2.12 kg [4.66 lb]
<b>CPI-KA760-DM-RD25-A6</b>	1/8 NPT	6 (3/3)	2.15 kg [4.75 lb]

### Style 05 - **KA760** 90° Robot Adaptor (Ø160mm Bolt Circle)

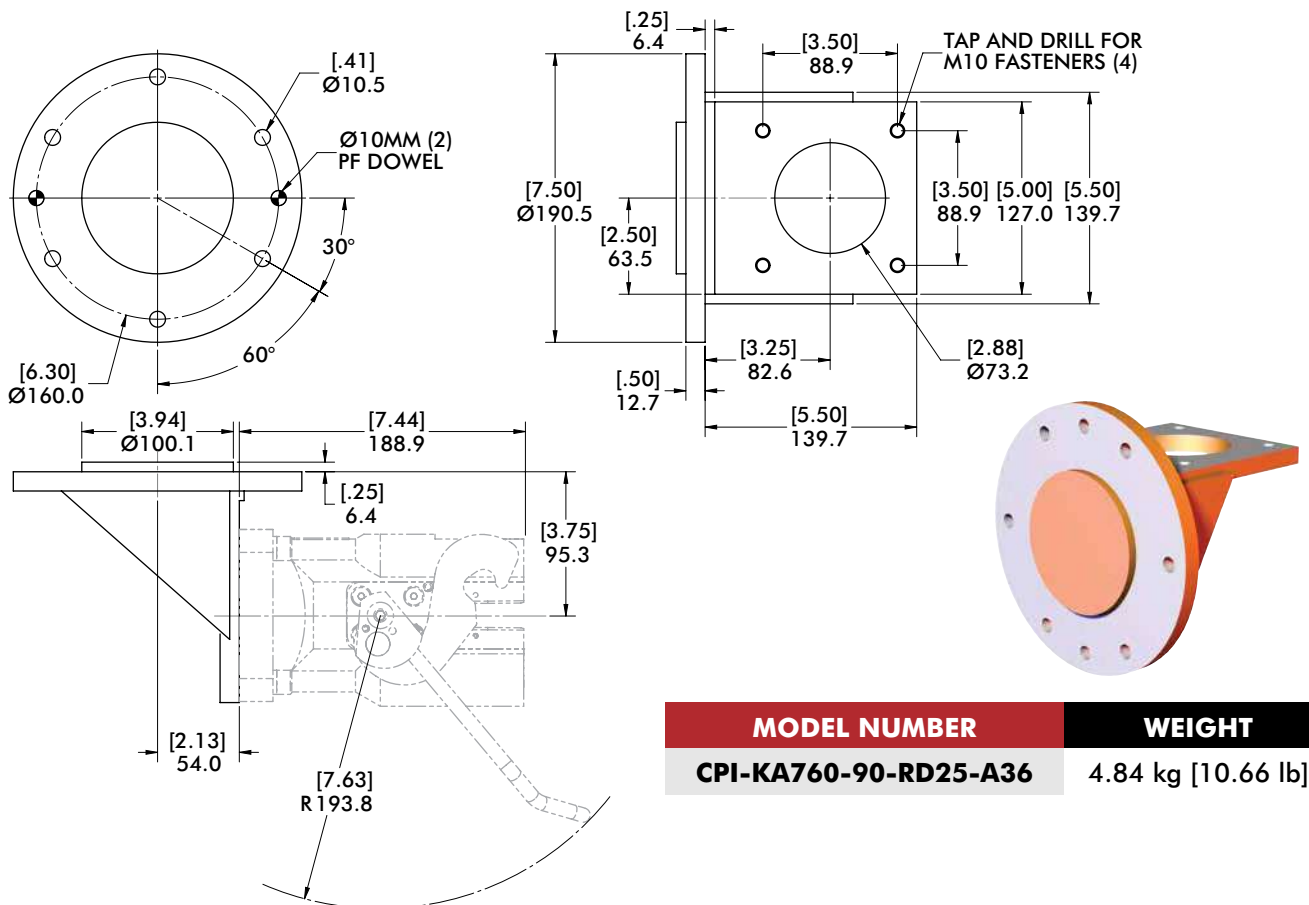

MODEL NUMBER	WEIGHT
<b>CPI-KA760-90-RD25-A36</b>	4.84 kg [10.66 lb]

# MMNY300

## Robot Automation Adaptors | Dimensions

### Style 06 - **MMNY300** Direct Mount Adaptor (Ø200mm Bolt Circle)

**Models Supported:**  
MOTOMAN SP100X  
KUKA KR 350

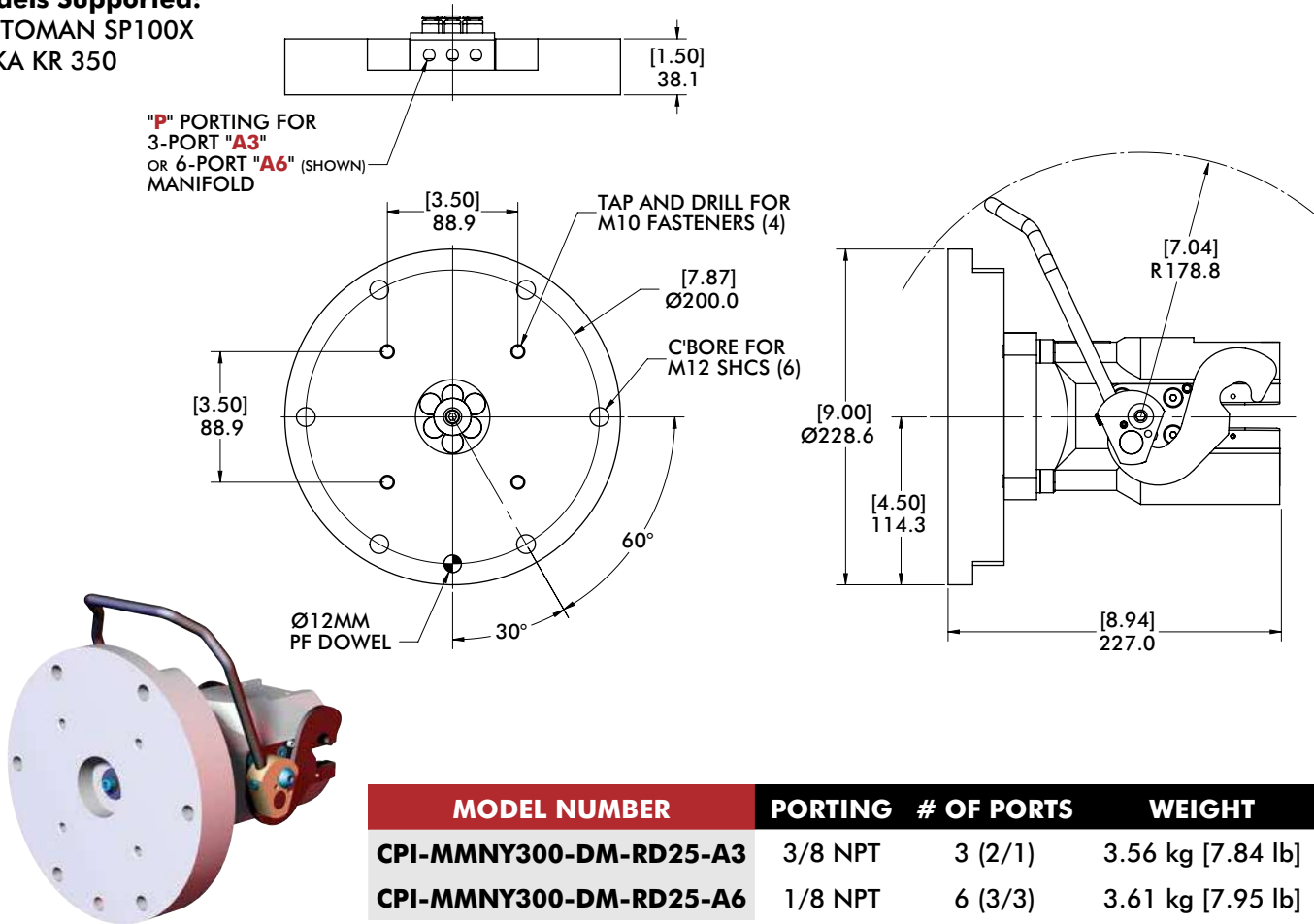

MODEL NUMBER	PORTING	# OF PORTS	WEIGHT
<b>CPI-MMNY300-DM-RD25-A3</b>	3/8 NPT	3 (2/1)	3.56 kg [7.84 lb]
<b>CPI-MMNY300-DM-RD25-A6</b>	1/8 NPT	6 (3/3)	3.61 kg [7.95 lb]

### Style 07 - FA430i Direct Mount Adaptor (Ø125mm Bolt Circle)

**Models Supported:**  
FANUC S430i

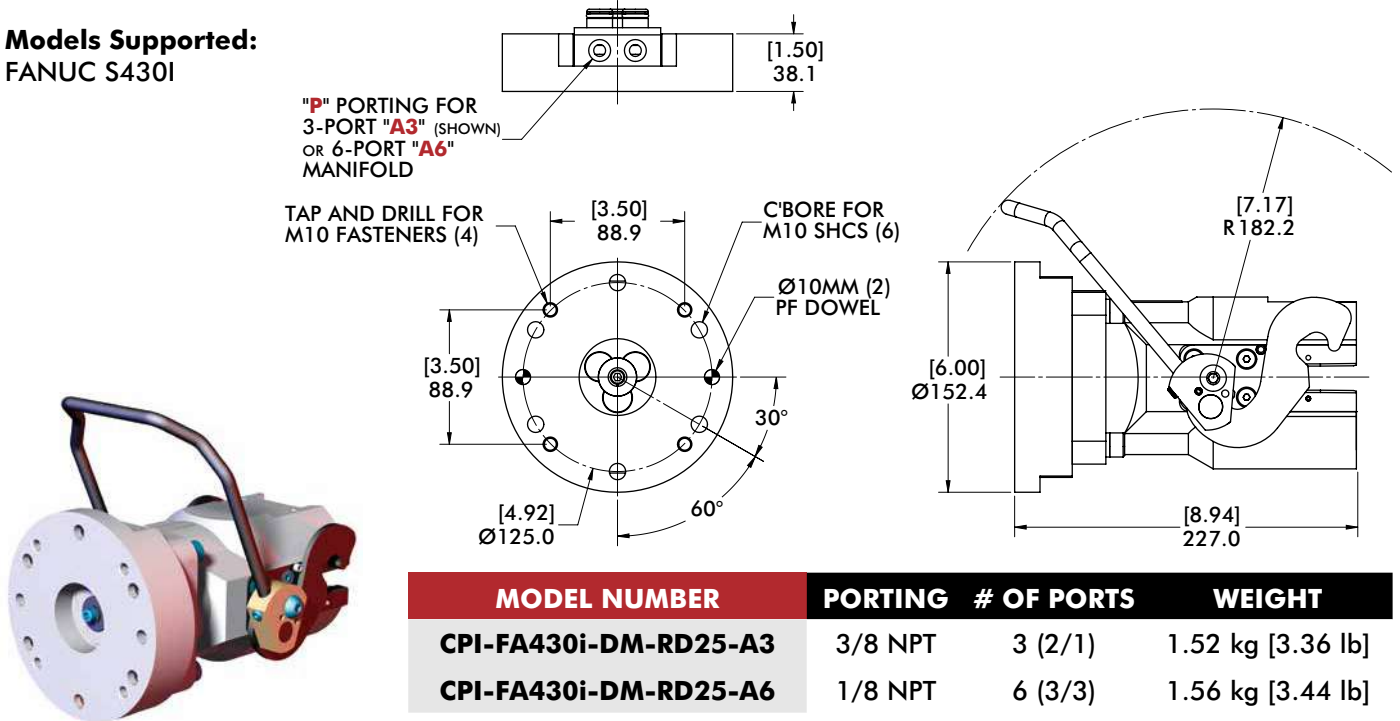

### Style 07 - FA430i 90° Robot Adaptor (Ø125mm Bolt Circle)

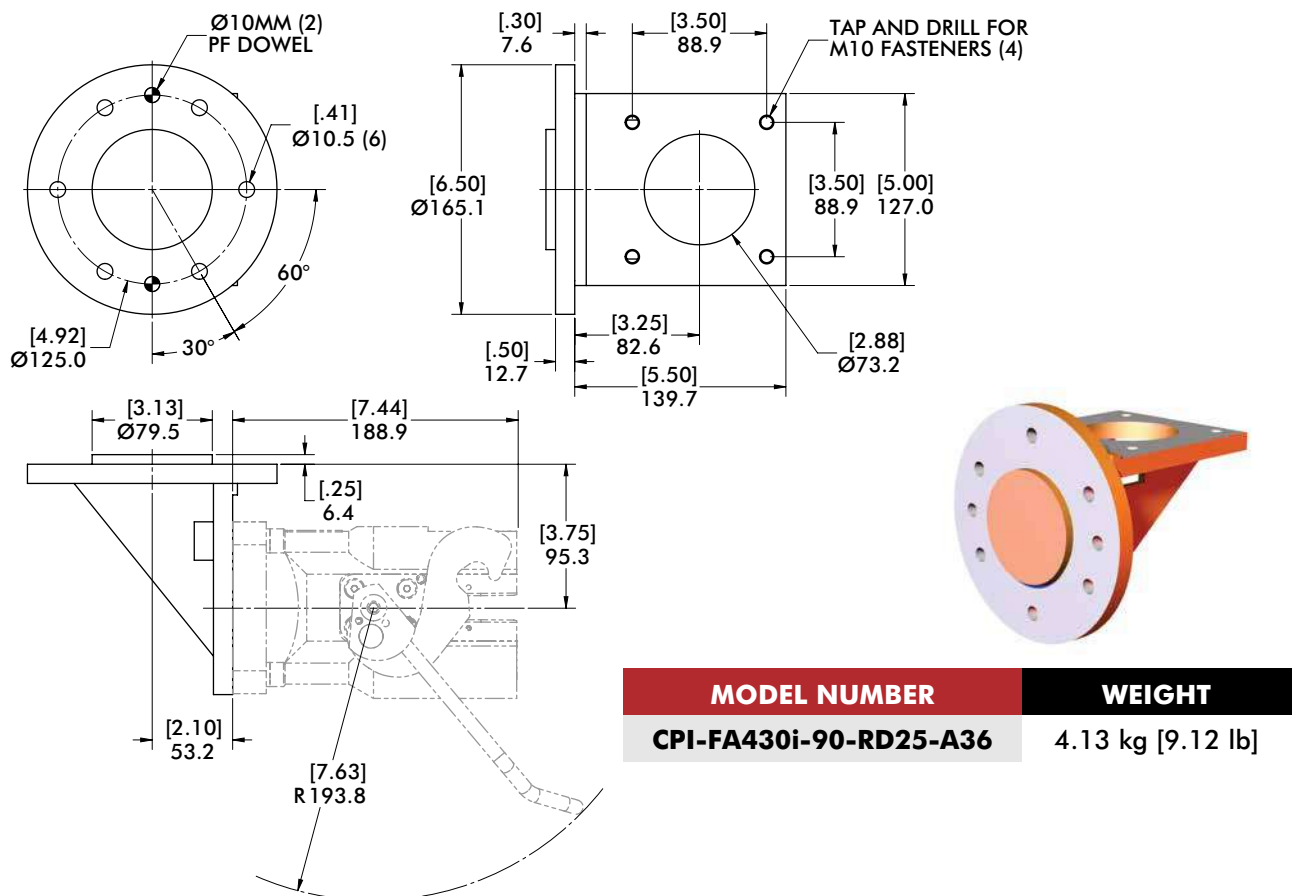

# FA420

## Robot Automation Adaptors | Dimensions

### Style 08 - FA420 Direct Mount Adaptor (Ø92mm Bolt Circle)

#### Models Supported:

FANUC S420 (WITH SPECIAL FLANGE)

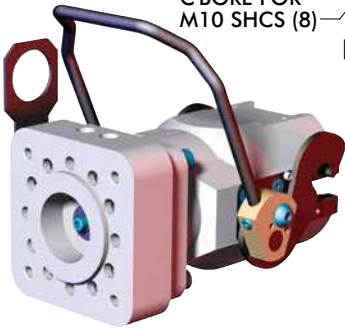
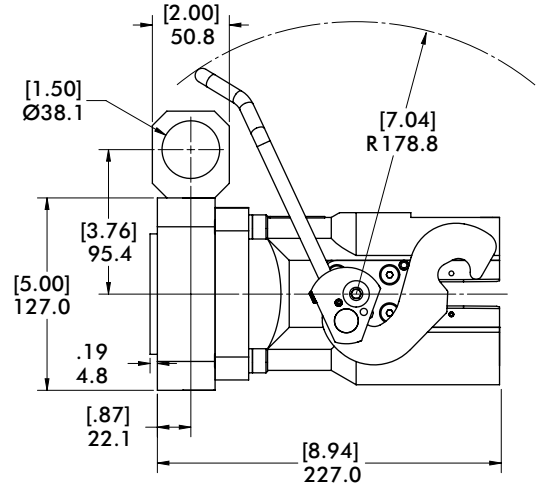
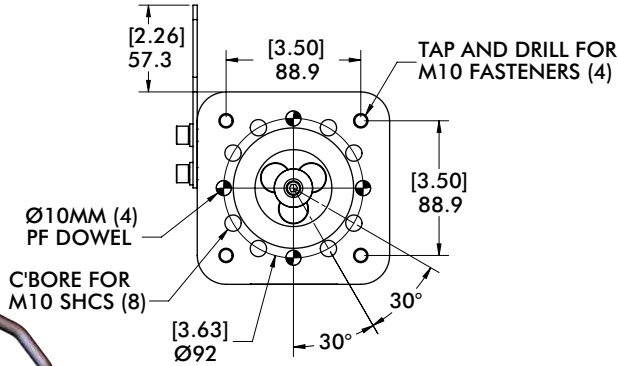
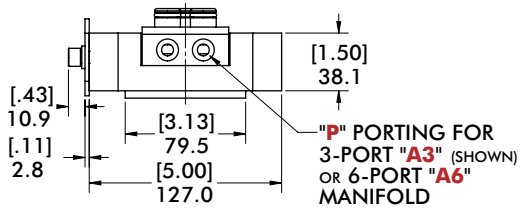

MODEL NUMBER	PORTING	# OF PORTS	WEIGHT
CPI-FA420-DM-RD25-A3-SPC	3/8 NPT	3 (2/1)	1.48 kg [3.27 lb]
CPI-FA420-DM-RD25-A6-SPC	1/8 NPT	6 (3/3)	1.52 kg [3.35 lb]

### Style 09 - ABB44 Direct Mount Adaptor (Ø100mm Bolt Circle)

#### Models Supported:

- ABB IRB 4400/S
- ABB IRB 4400/60
- ABB IRB 4400/45
- ABB IRB 4400/L30

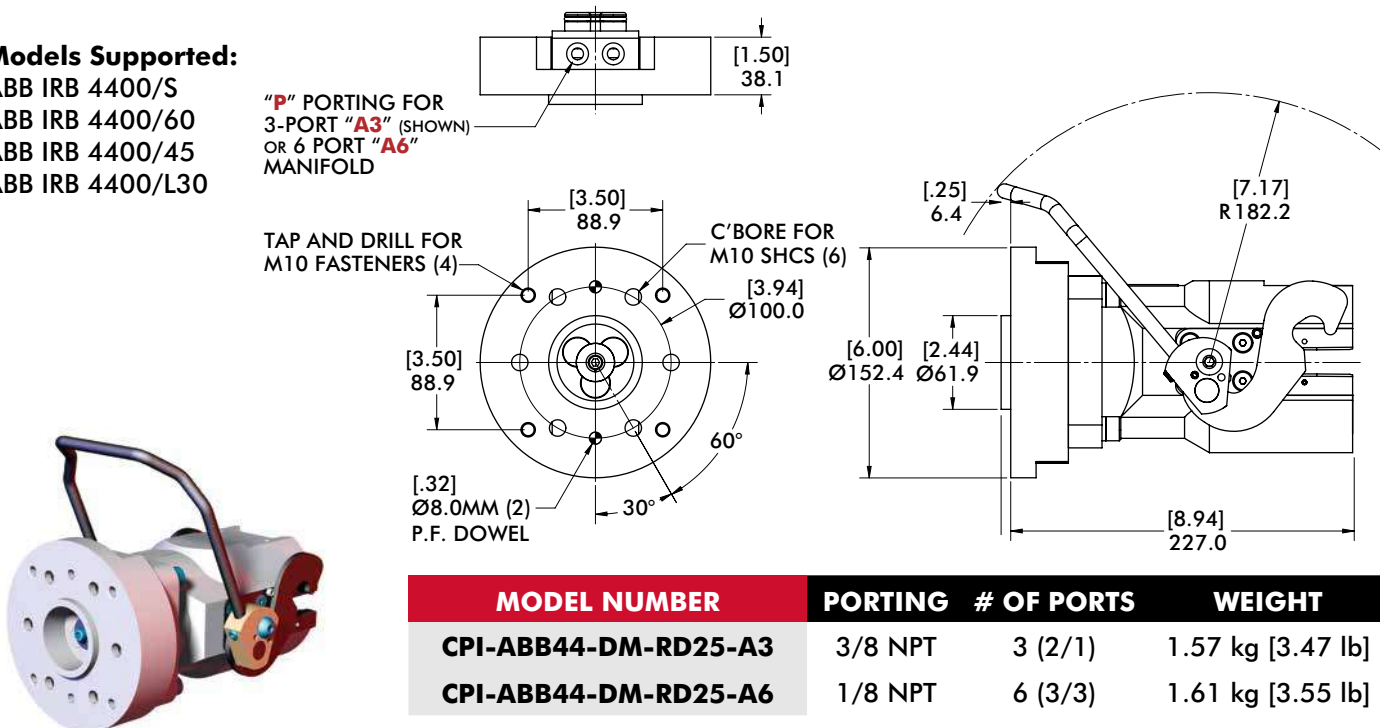

### Style 09 - ABB44 90° Robot Adaptor (Ø100mm Bolt Circle)

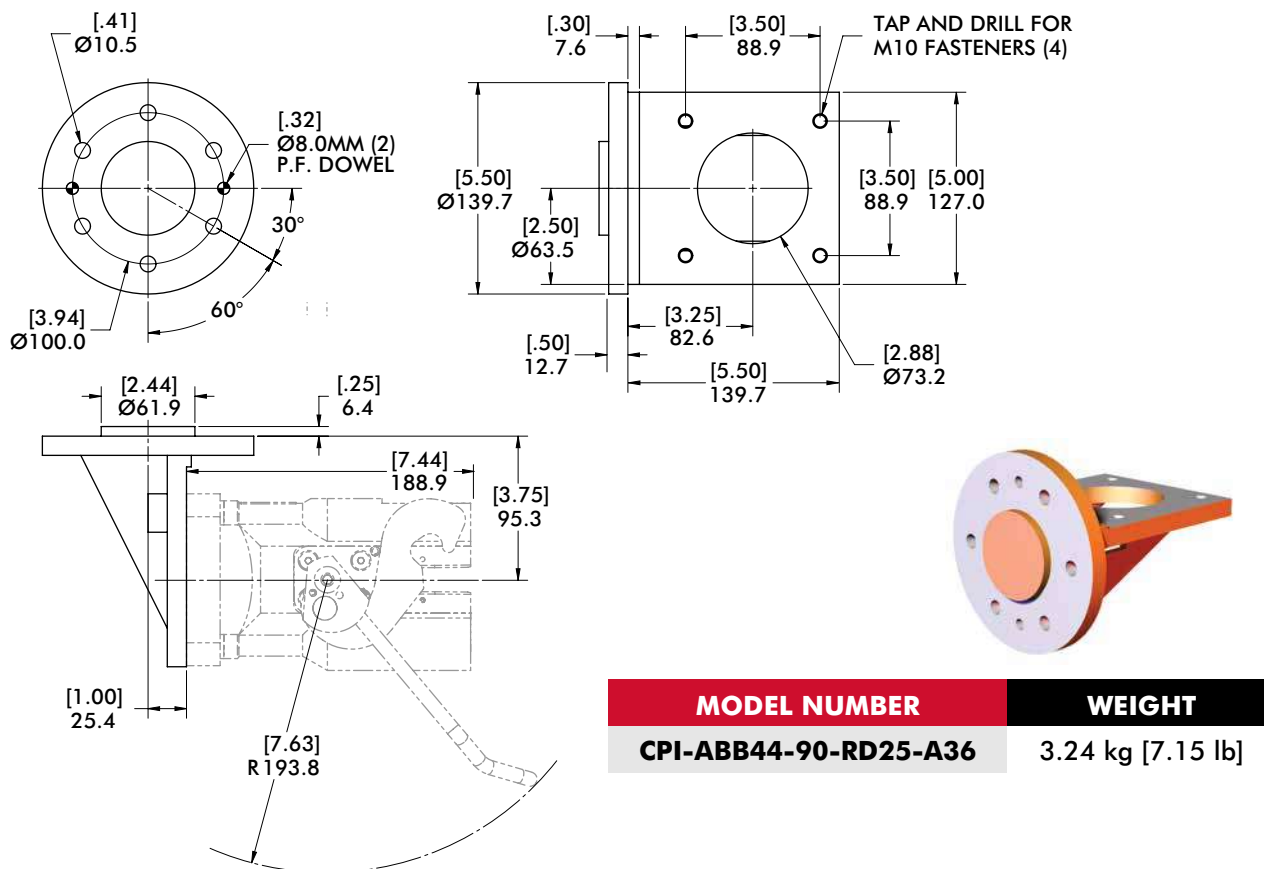

# KWZ165

## Robot Automation Adaptors | Dimensions

### Style 10 - KWZ165 Direct Mount Adaptor (Ø125mm Bolt Circle)

**Models Supported:**  
KAWASAKI Z165

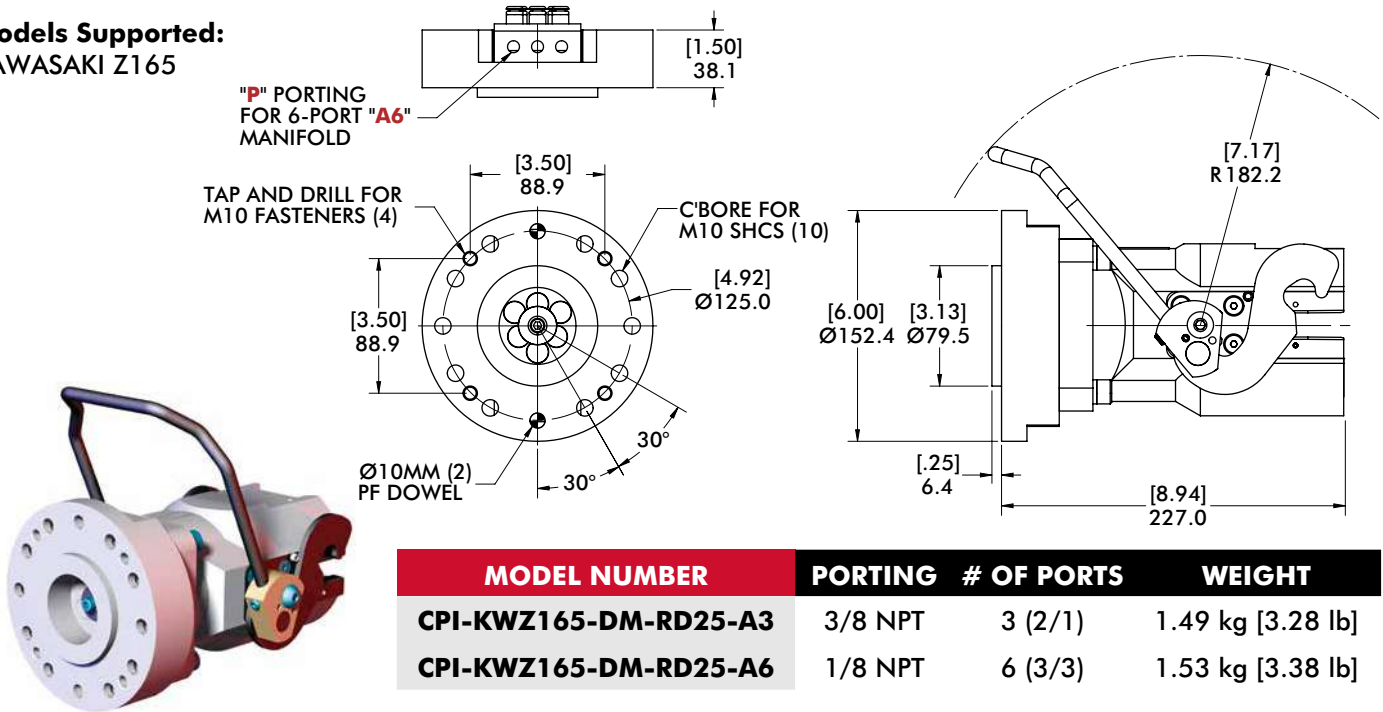

### Style 10 - KWZ165 90° Robot Adaptor (Ø125mm Bolt Circle)

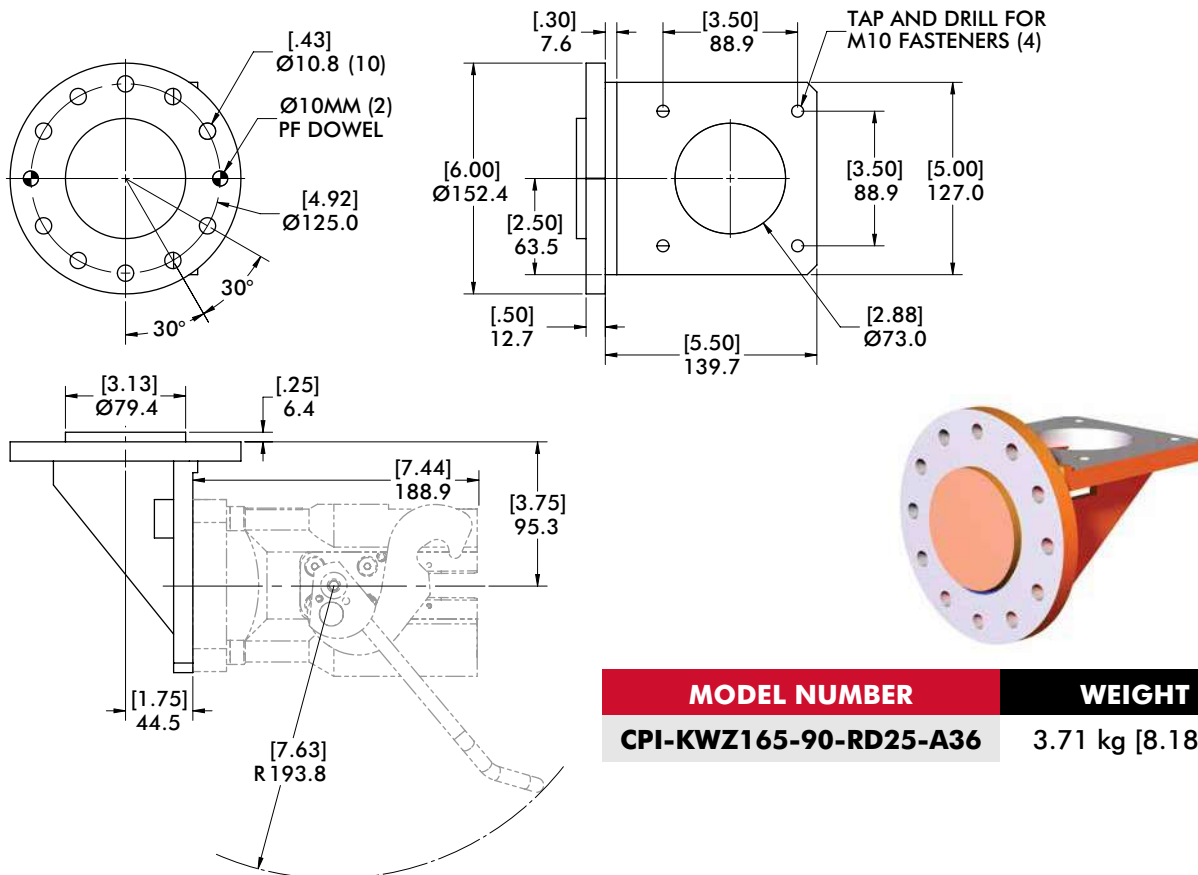



Style 11 - **KWUT120** 90° Adaptor (Ø120mm Bolt Circle)

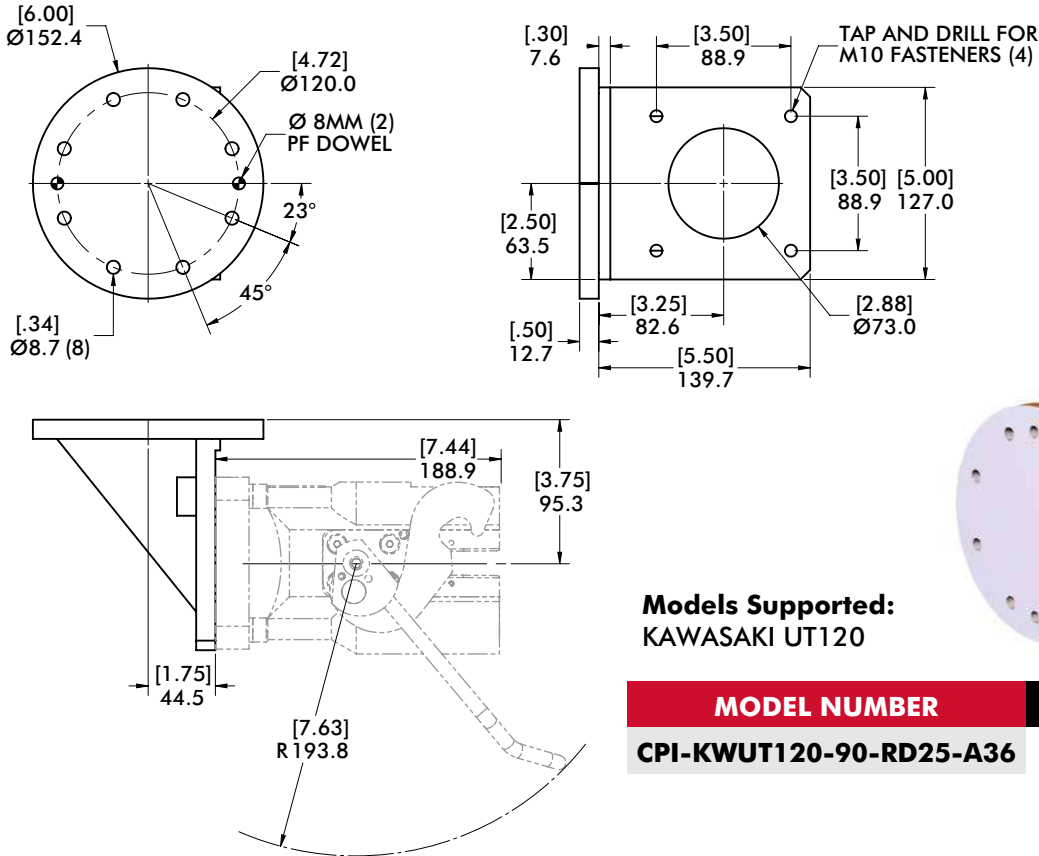

**Models Supported:**  
KAWASAKI UT120

MODEL NUMBER	WEIGHT
CPI-KWUT120-90-RD25-A36	3.58 kg [7.90 lb]

# FA710

## Robot Automation Adaptors | Dimensions

### Style 12 - FA710 Direct Mount Adaptor (Ø100mm Bolt Circle)

#### Models Supported:

FANUC M710

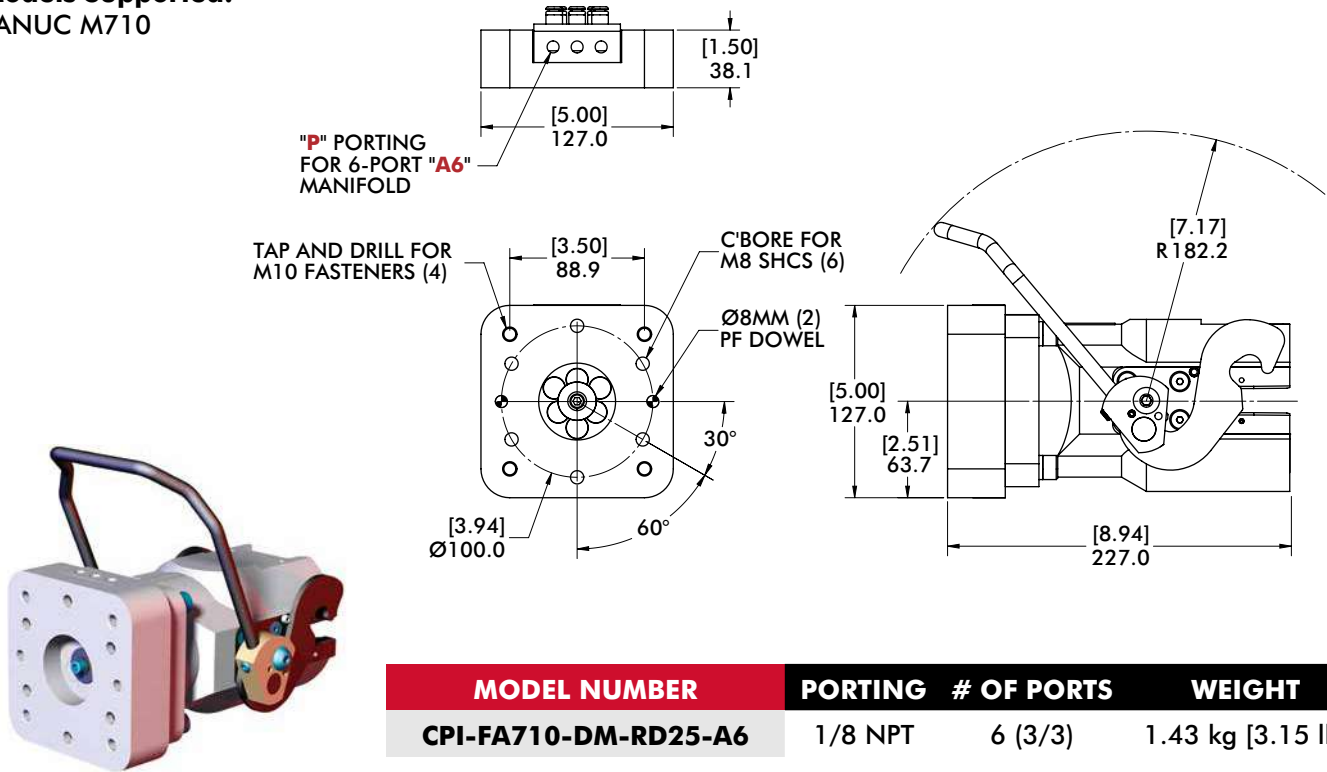

MODEL NUMBER	PORTING	# OF PORTS	WEIGHT
CPI-FA710-DM-RD25-A6	1/8 NPT	6 (3/3)	1.43 kg [3.15 lb]

### Style 14 - **MMK100** 90° Adaptor (Ø125mm Bolt Circle)

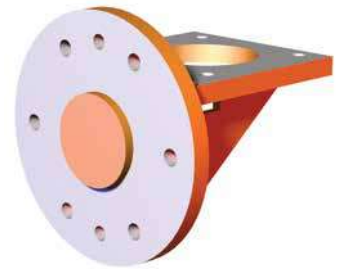
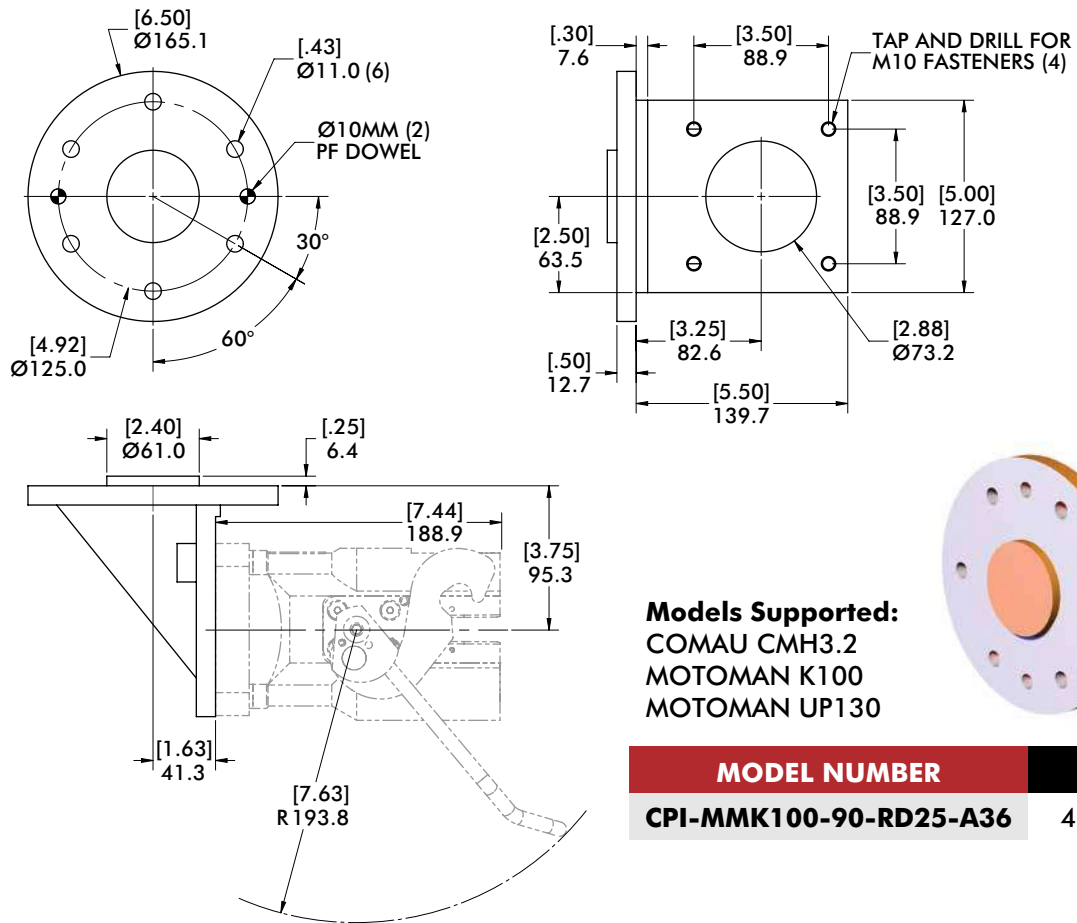

**Models Supported:**  
 COMAU CMH3.2  
 MOTOMAN K100  
 MOTOMAN UP130

MODEL NUMBER	WEIGHT
CPI-MMK100-90-RD25-A36	4.03 kg [8.88 lb]

# KA660

## Robot Automation Adaptors | Dimensions

### Style 15 - **KA660** Direct Mount Adaptor (Ø160mm Bolt Circle)

**Models Supported:**  
KUKA 660

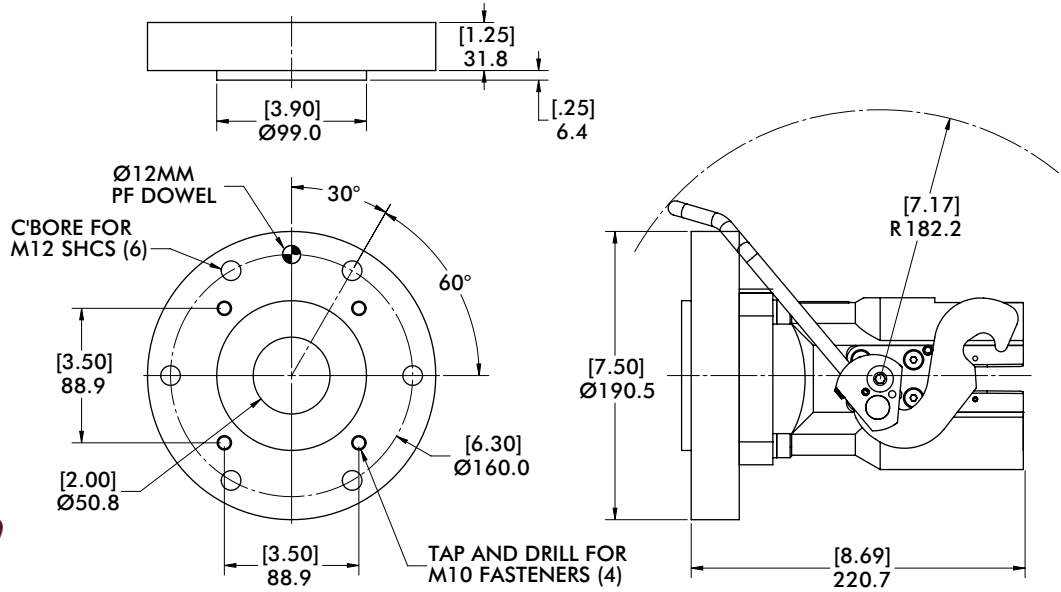

MODEL NUMBER	PORTING	# OF PORTS	WEIGHT
CPI-KA660-DM-RD25-00	N/A	N/A	2.23 kg [4.92 lb]

### Style 15 - **KA660** 90° Robot Adaptor (Ø160mm Bolt Circle)

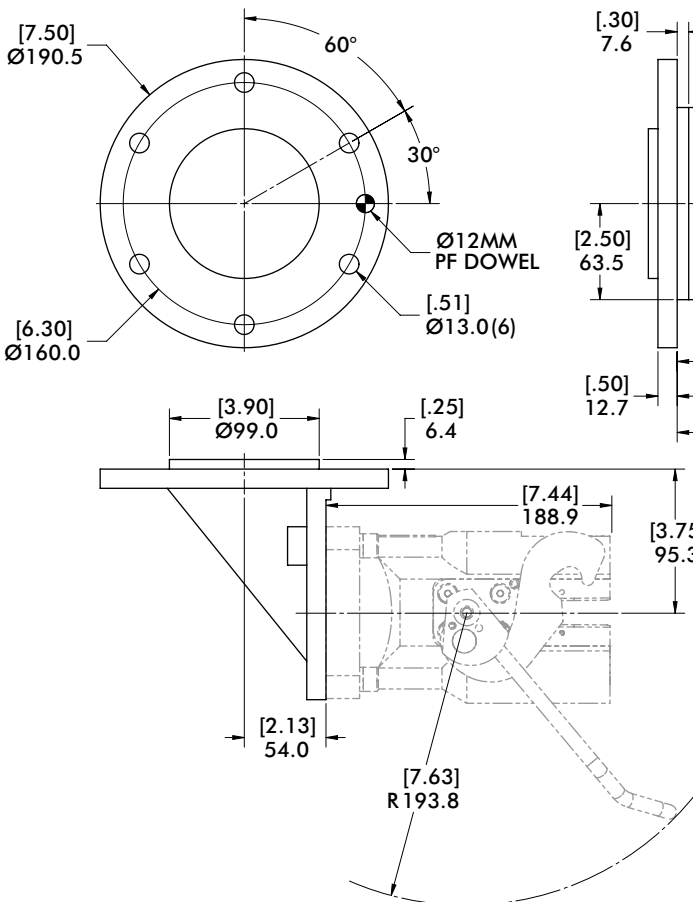

MODEL NUMBER	WEIGHT
CPI-KA660-90-RD25-A36	4.95 kg [10.91 lb]

### Style 16 - FA2000 Direct Mount Adaptor (Ø125mm Bolt Circle)

**Models Supported:**  
FANUC R2000I

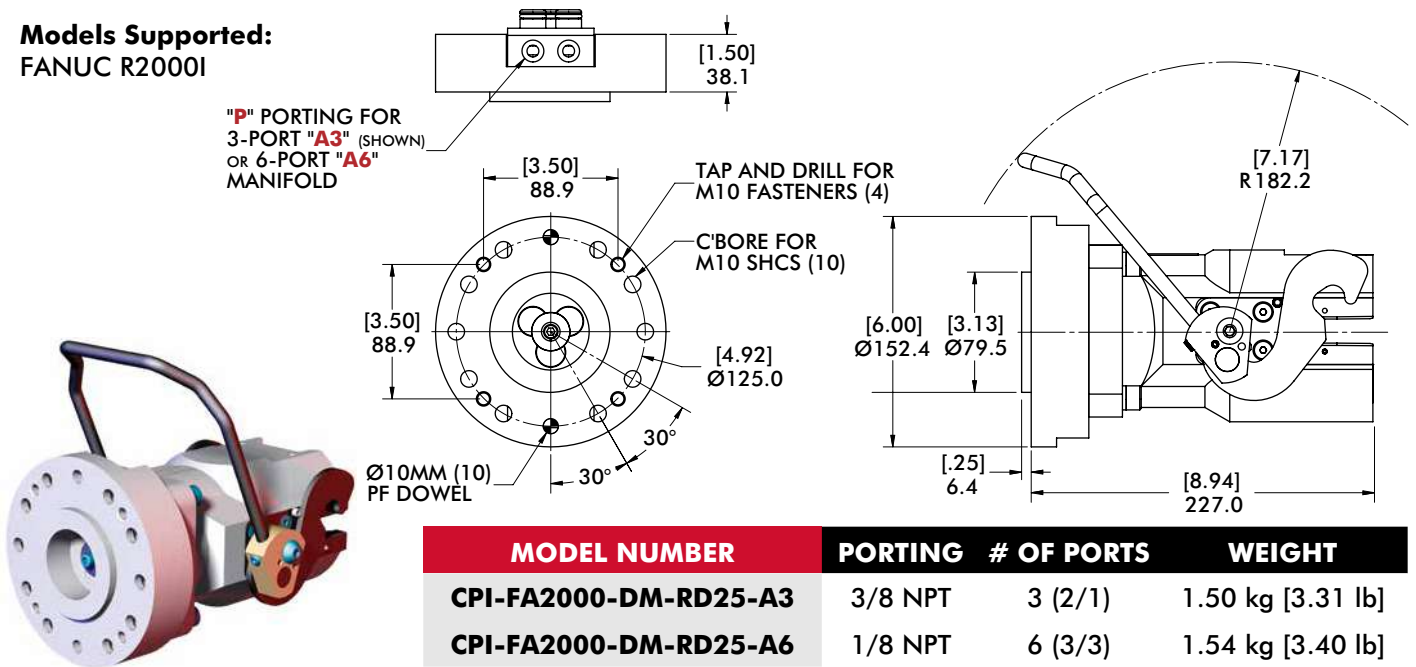

### Style 16 - FA2000 90° Robot Adaptor (Ø125mm Bolt Circle)

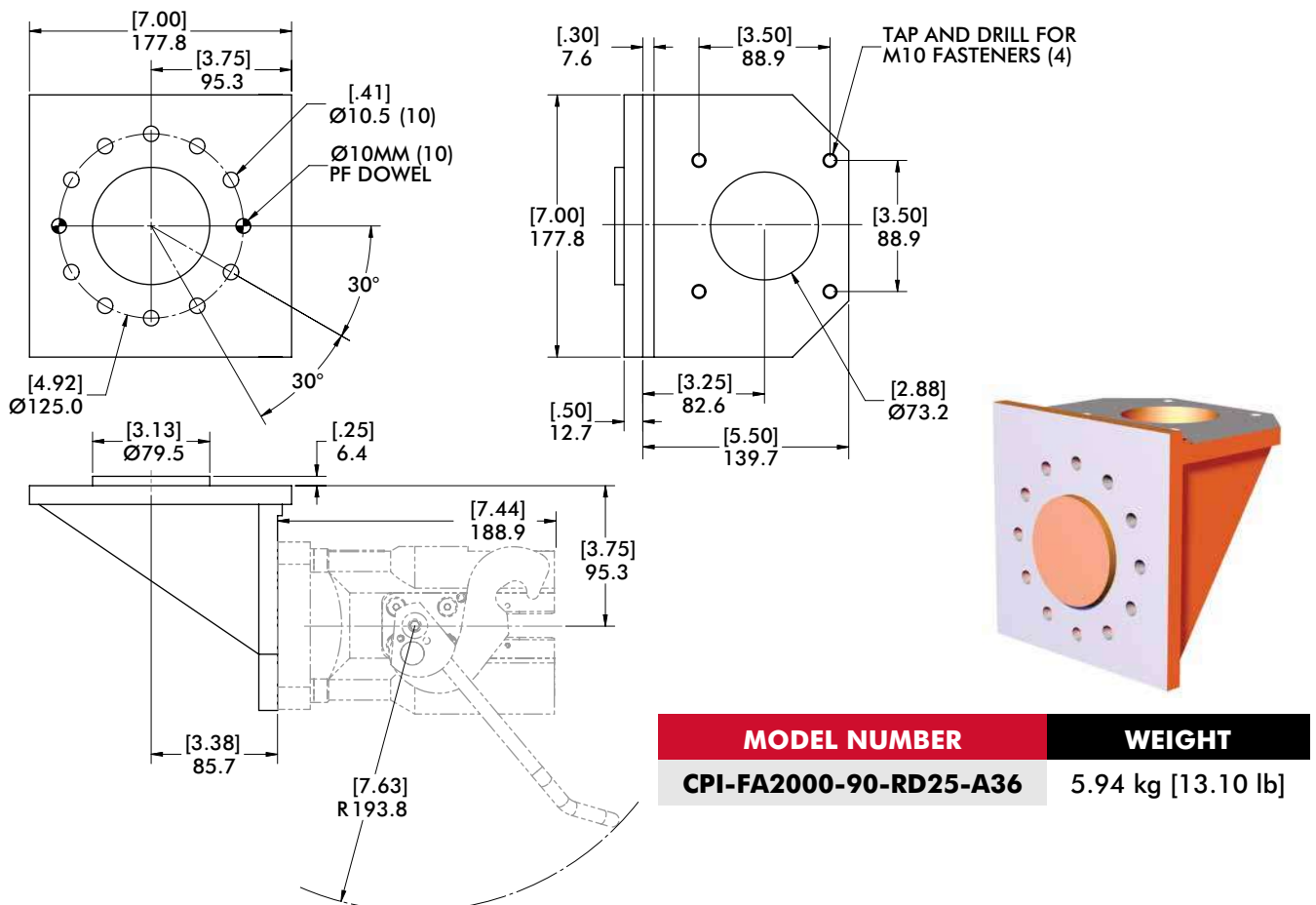

# MMHP165

## Robot Automation Adaptors | Dimensions

### Style 15 - **KA660** Direct Mount Adaptor (Ø160mm Bolt Circle)

**Models Supported:**  
MOTOMAN ES165N  
MOTOMAN HP165

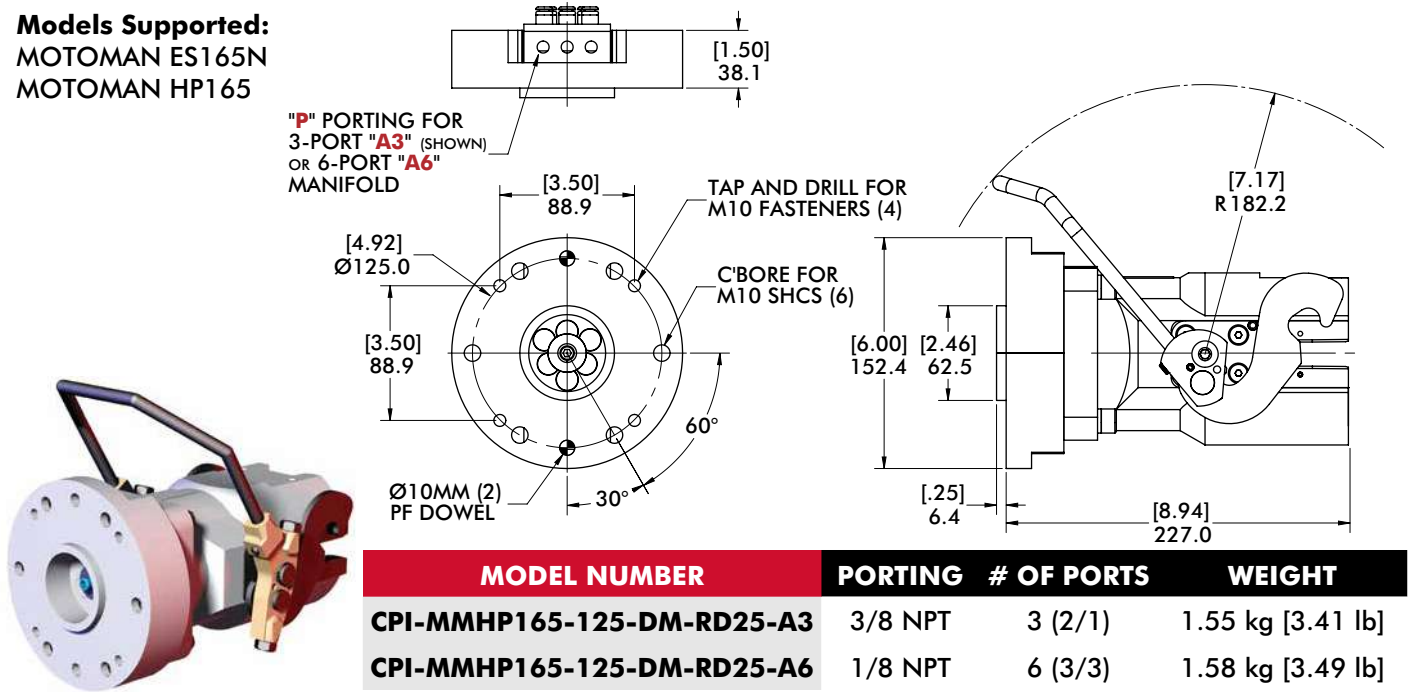

### Style 15 - **KA660** 90° Robot Adaptor (Ø125mm Bolt Circle)

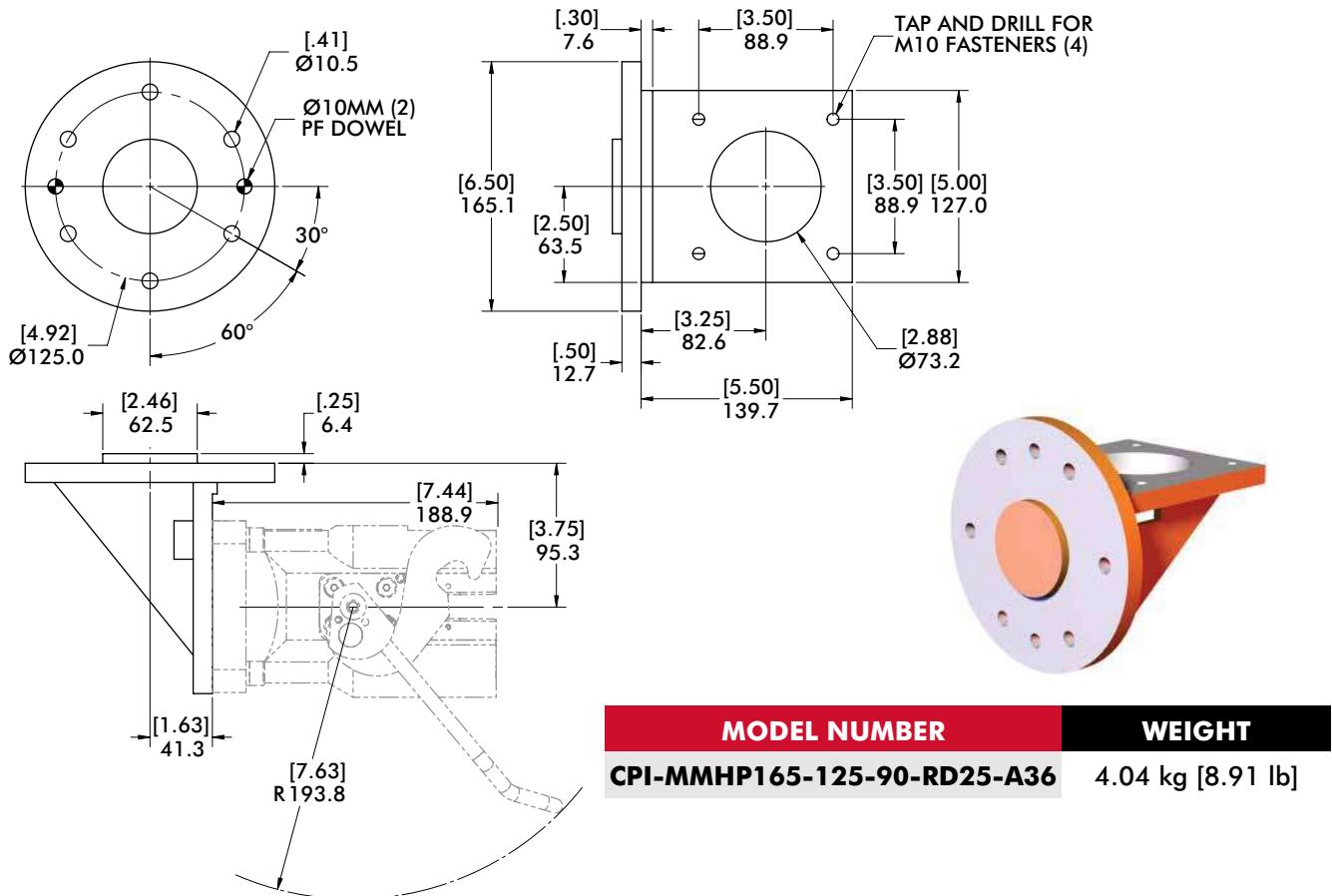

### Style 19 - **MMHP165** 90° Adaptor (Ø92mm Bolt Circle)

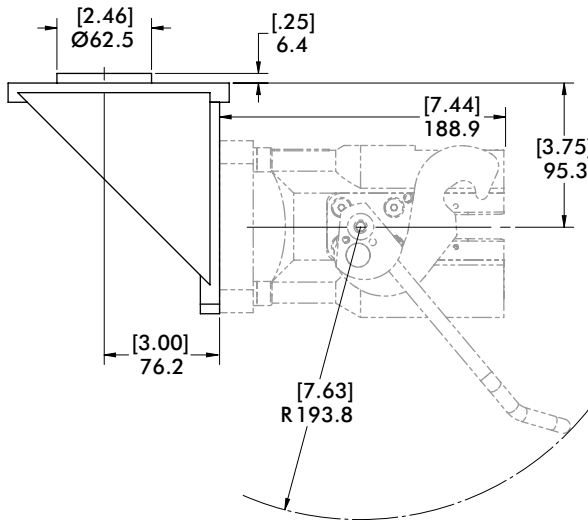
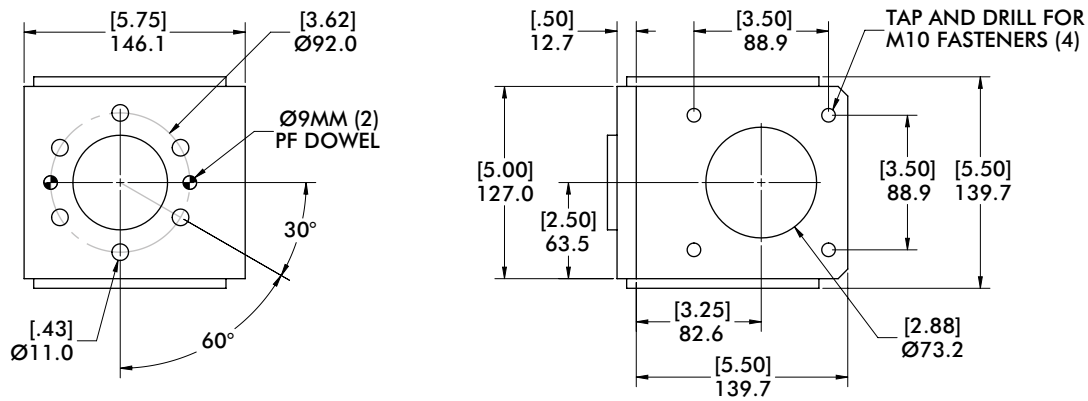

**Models Supported:**  
 HP165  
 ES165N

MODEL NUMBER	WEIGHT
CPI-MMHP165-92-90-RD25-A36	4.03 kg [8.89 lb]

# EOAMC30, FA900-SSM

## Robot Automation Adaptors | Dimensions

### Style 21 - EOAMC30 Direct Mount Adaptor (Ø127mm Bolt Circle/Ø108mm Dowel Circle)

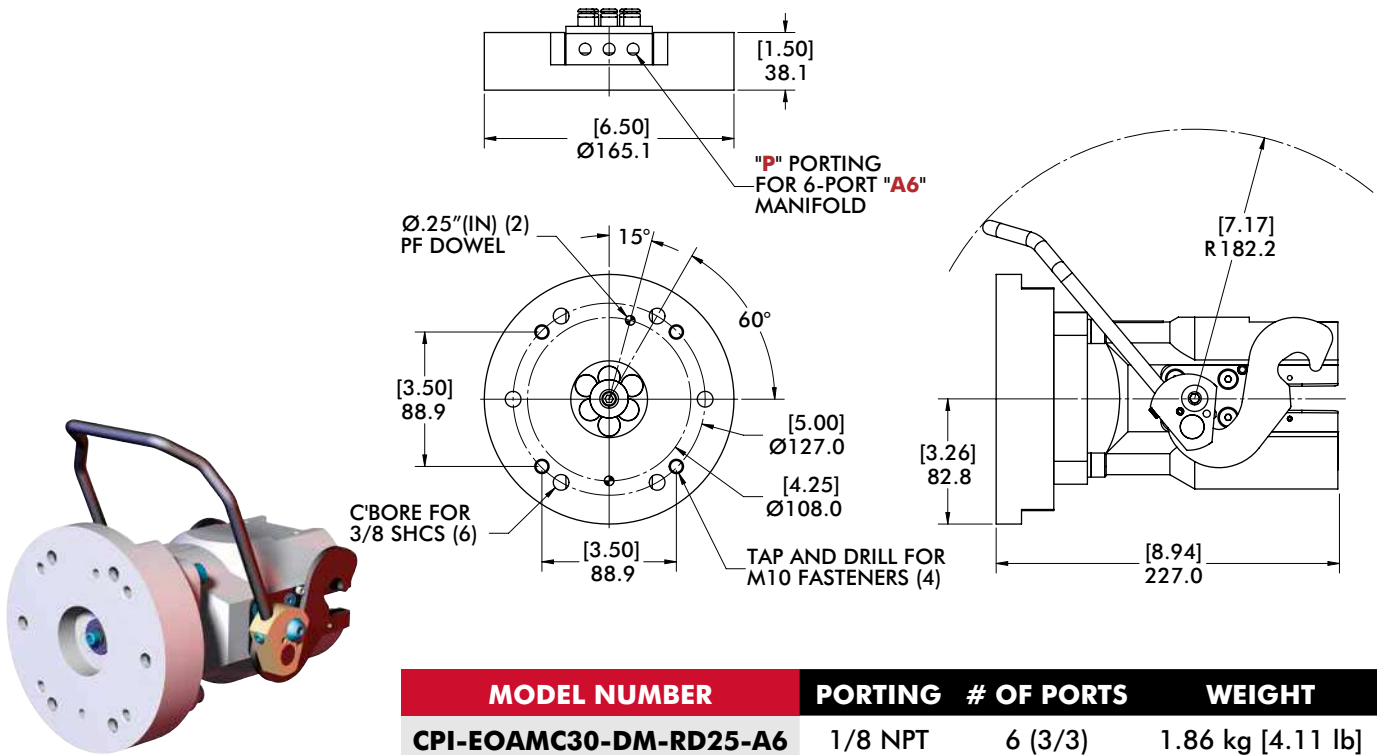

### Style 22 - FA900-SSM Direct Mount Adaptor (Ø125mm Bolt Circle)

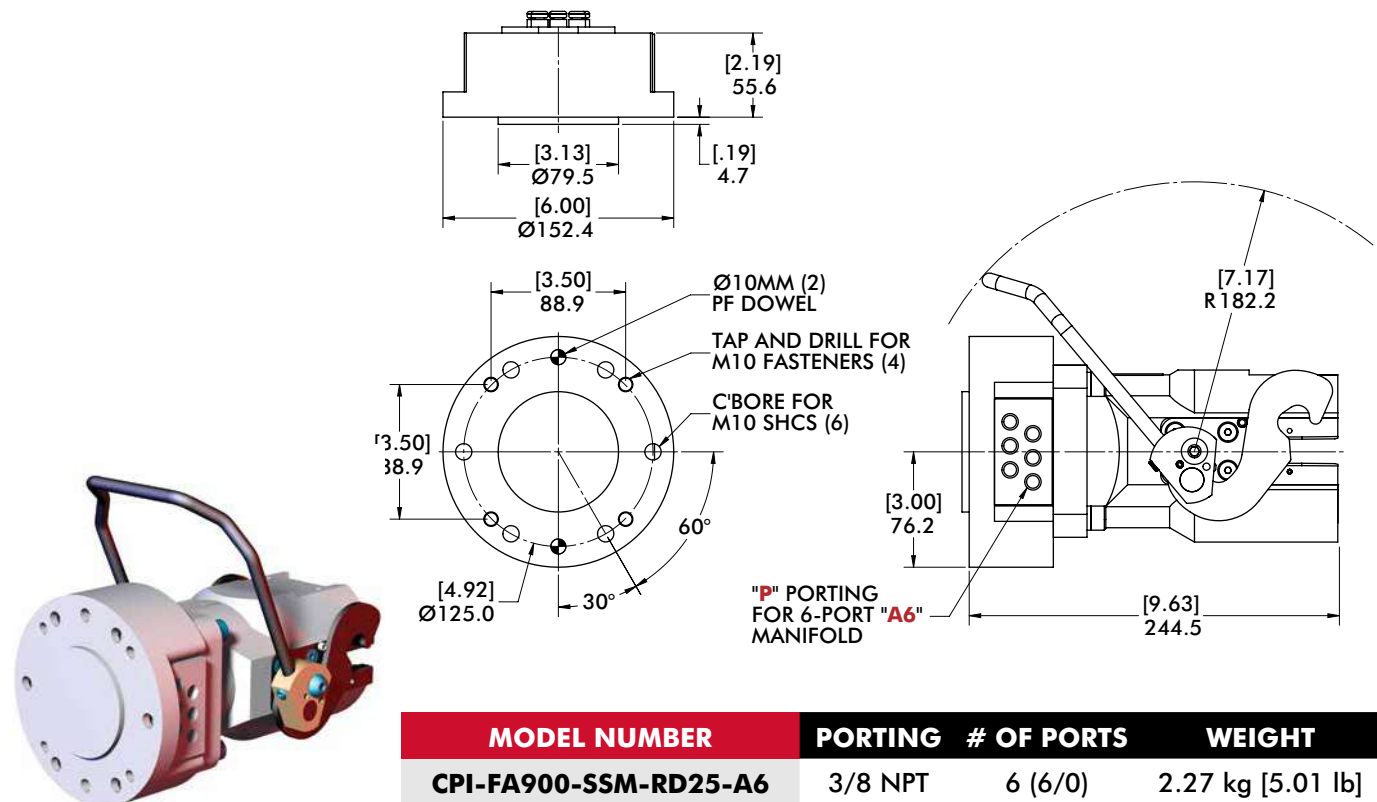



### Style 23 - MD350 Direct Mount Adaptor - Ø187.3mm Bolt Circle

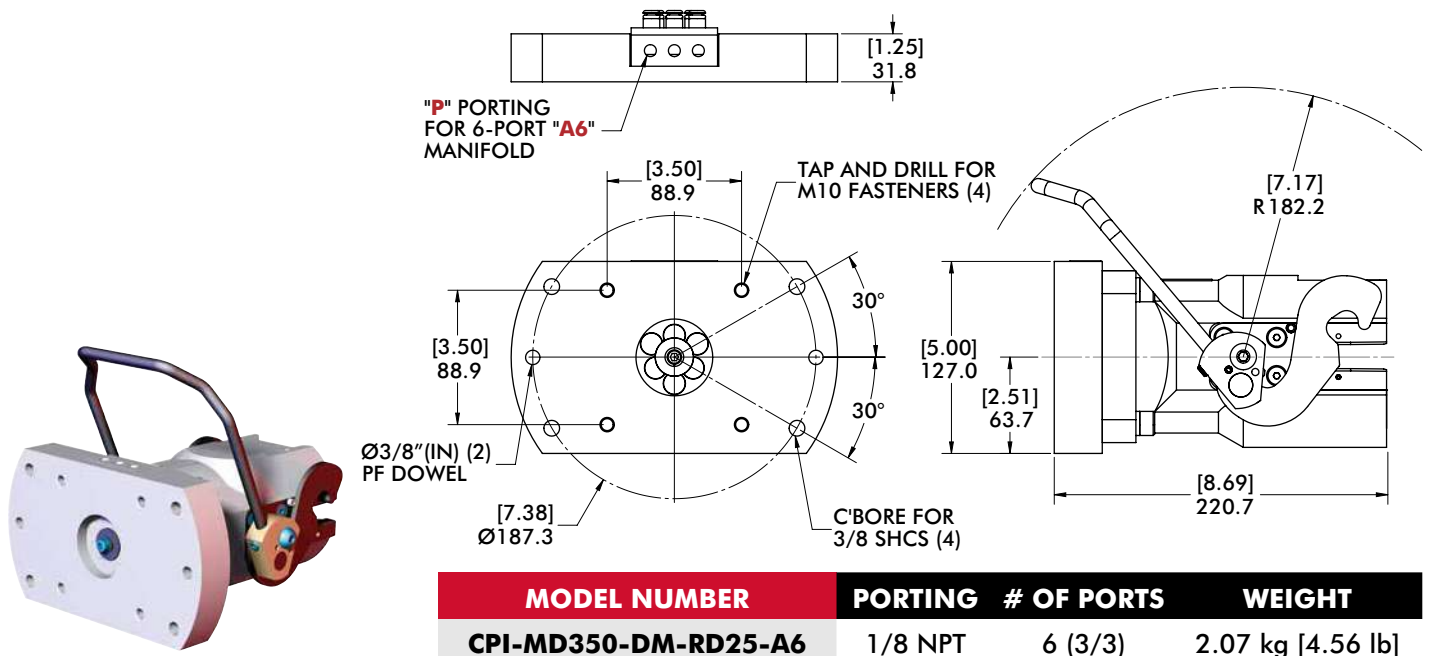

### Style 23 - MD350 90° Robot Adaptor

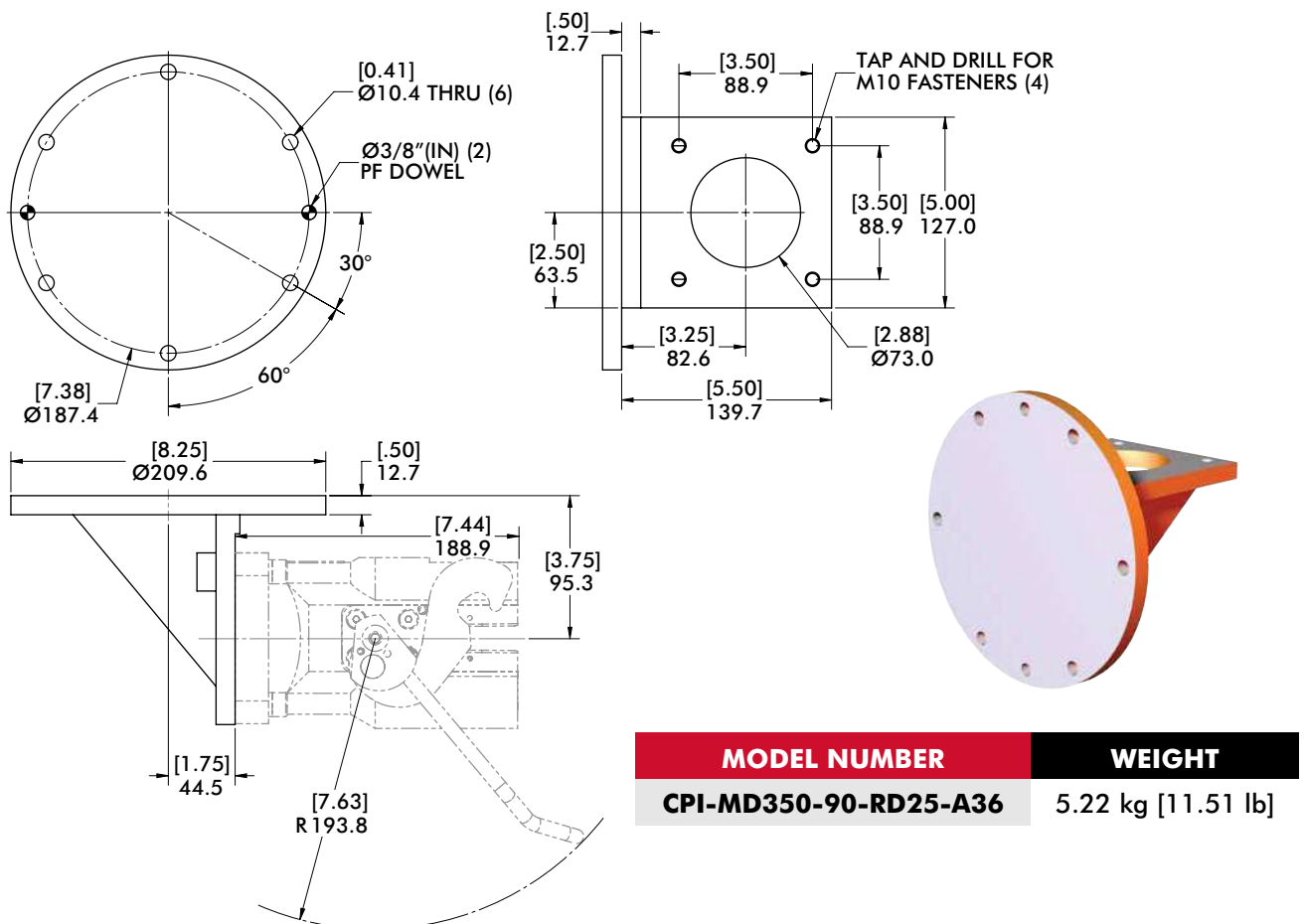

# SA000

## Robot Automation Adaptors | Dimensions

### Style 24 - SA000 Direct Mount Adaptor - Ø69.5mm Bolt Circle

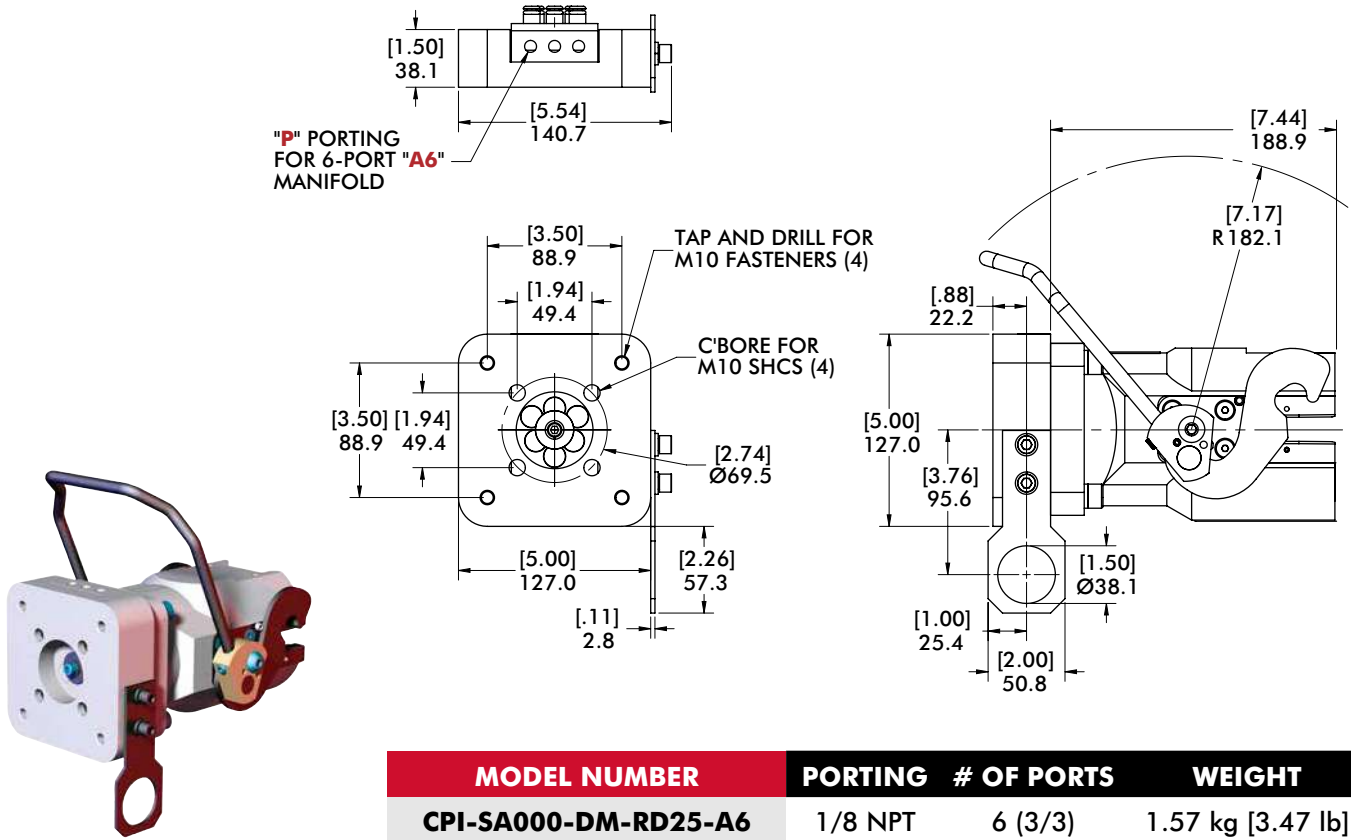

# CM975XL, CHM32

Robot Automation Adaptors | Dimensions

## CM975XL Direct Mount Adaptor - Ø76mm Bolt Circle

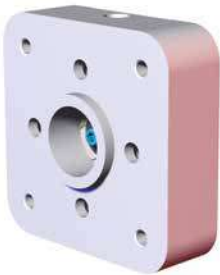
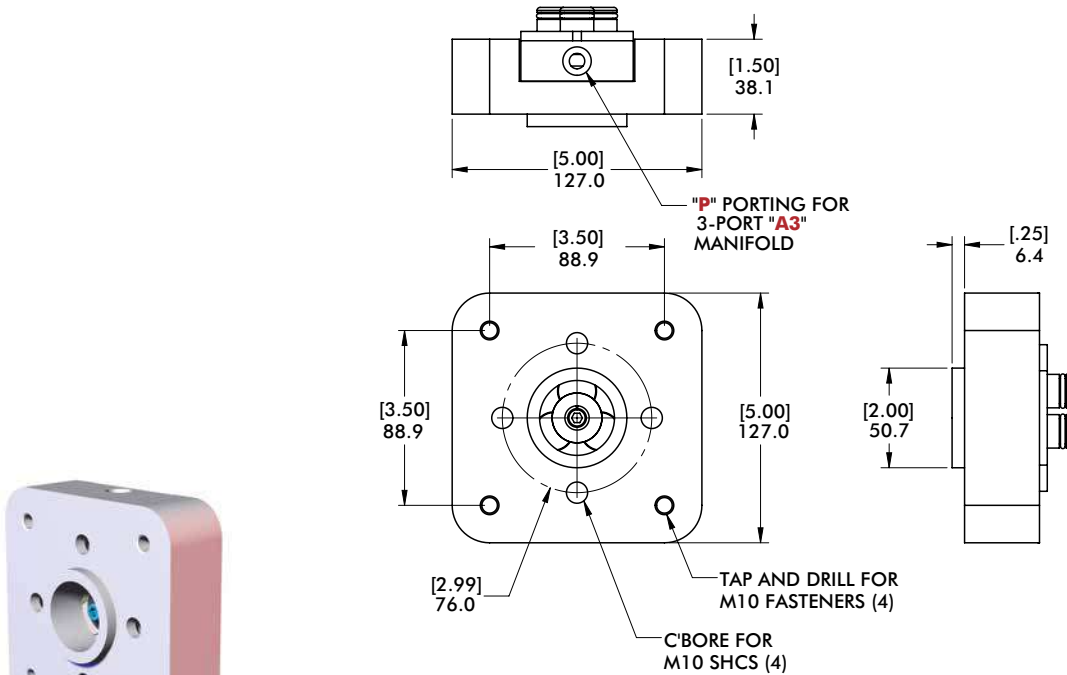

MODEL NUMBER	PORTING	# OF PORTS	WEIGHT
CPI-CM675XL-DM-RD25-A3	3/8 NPT	3 (2/1)	1.47 kg [3.24 lb]

## CHM32 Direct Mount Adaptor - Ø125mm Bolt Circle

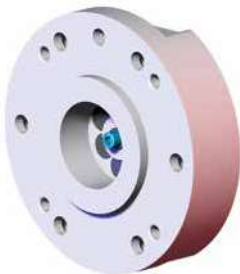
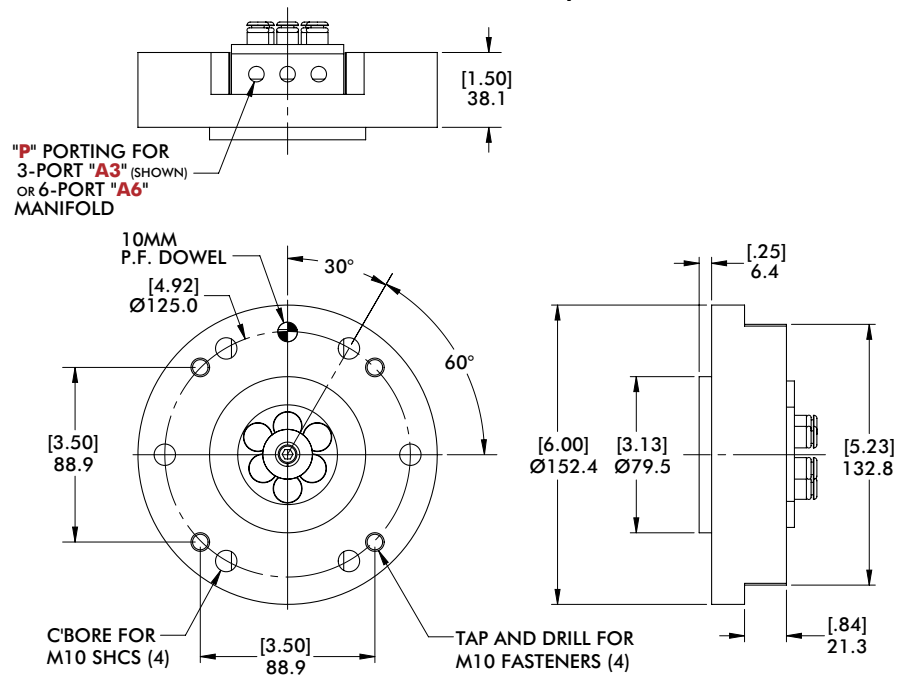

MODEL NUMBER	PORTING	# OF PORTS	WEIGHT
CPI-CHM32-DM-RD25-A3	3/8 NPT	3 (2/1)	2.38 kg [5.25 lb]
CPI-CHM32-DM-RD25-A6	1/8 NPT	6 (3/3)	2.42 kg [5.34 lb]

# FA710, FA710IC

## Robot Automation Adaptors | Dimensions

### FA710IC 90° Robot Adaptor - Ø100mm Bolt Circle

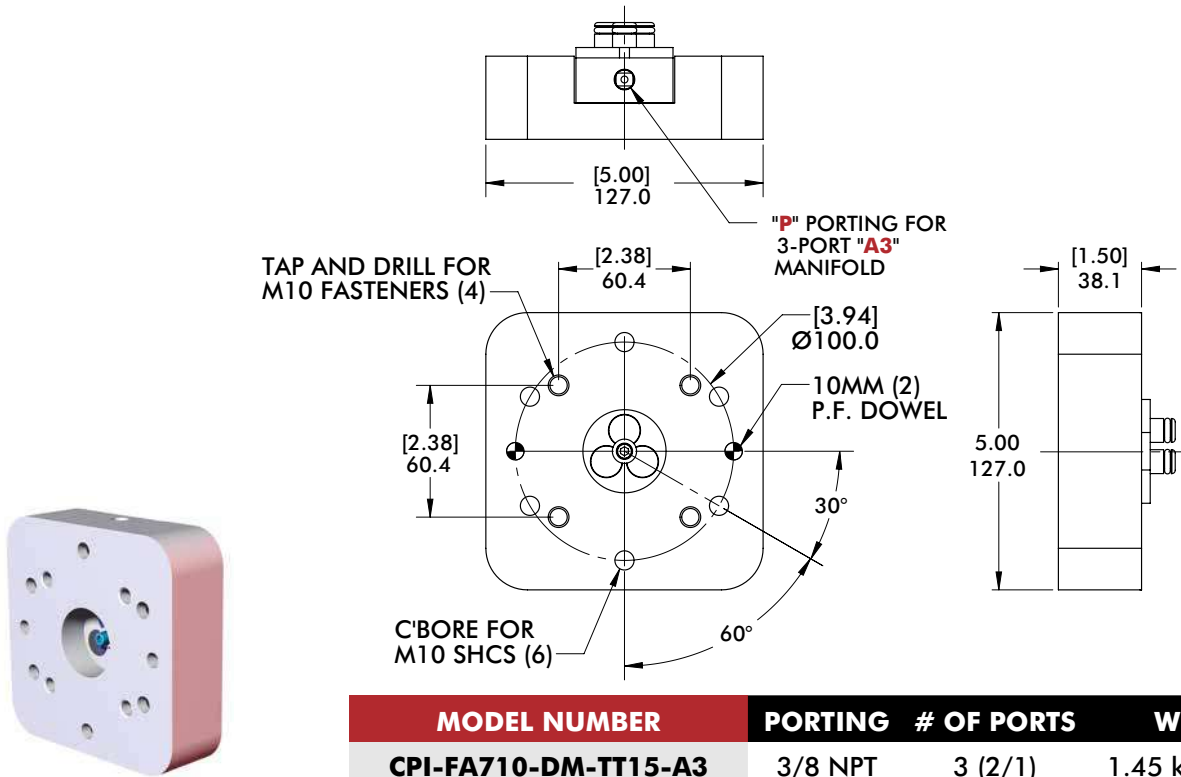

### FA710IC 90° Robot Adaptor - Ø100mm Bolt Circle

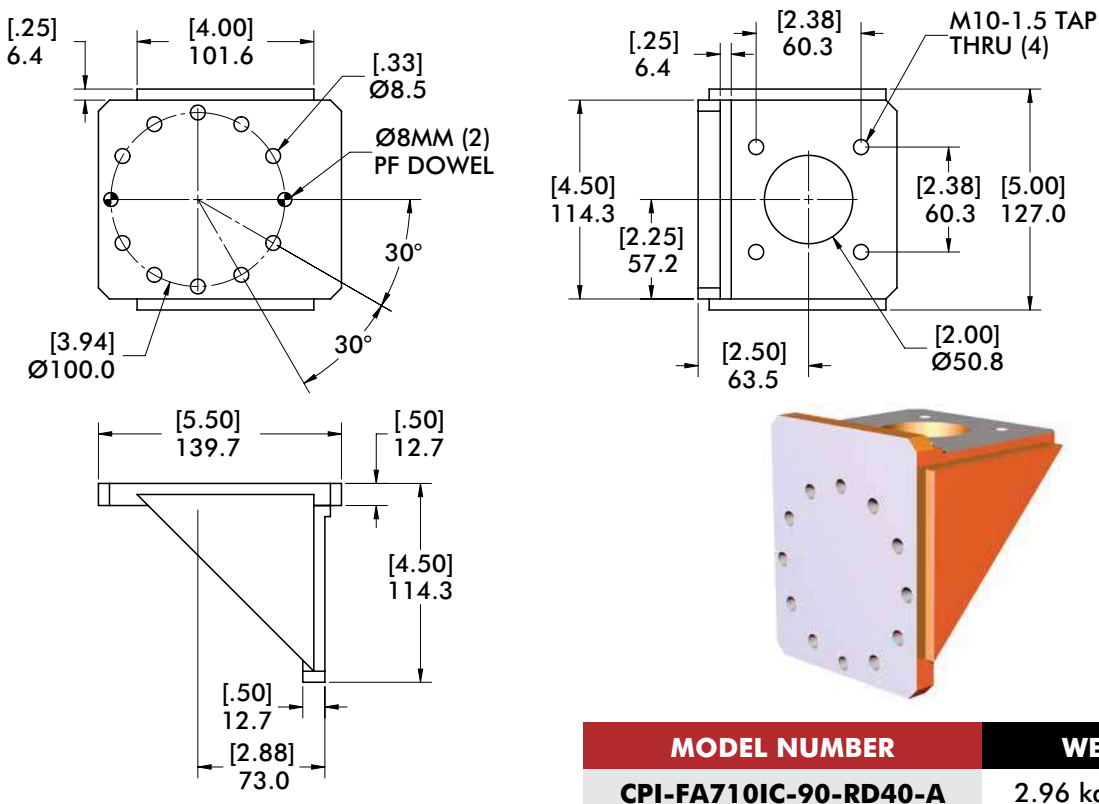

# TDA-150F, TDA-250F

Robot Automation Adaptors | Dimensions

## TDA-150F Direct Mount Adaptor Plate - Ø85mm Bolt Circle

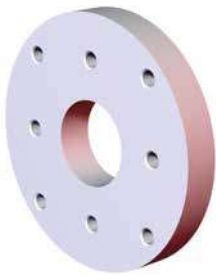
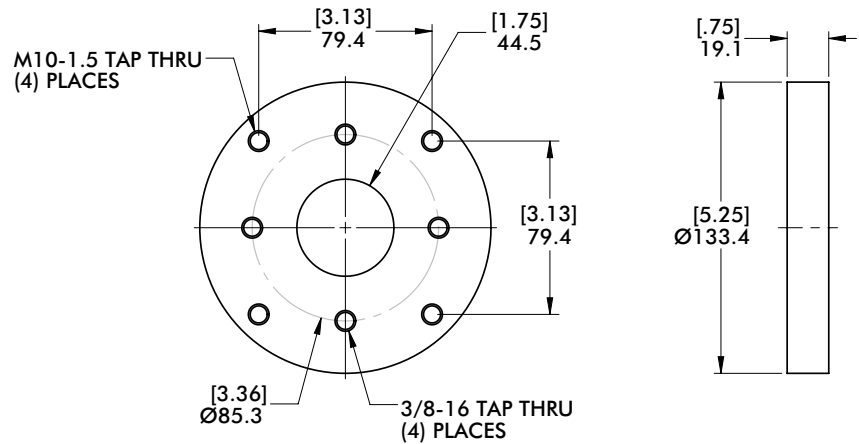

MODEL NUMBER	WEIGHT
CPI-TDA-150F-312F	.62 kg [1.36 lb]

## TDA-250F Direct Mount Adaptor Plate - Ø125mm Bolt Circle

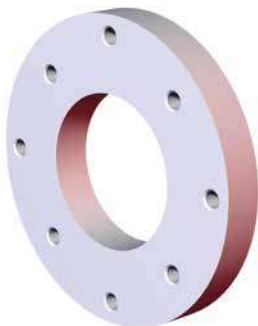
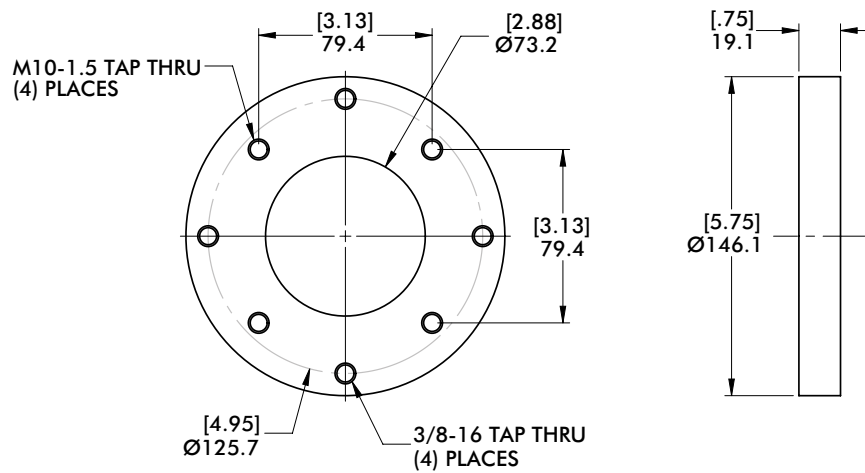

MODEL NUMBER	WEIGHT
CPI-TDA-250F-312F	.63 kg [1.38 lb]

# FA900, KW150

## Robot Automation Adaptors | Dimensions

### FA900 Direct Mount Adaptor Plate - Ø125mm Bolt Circle

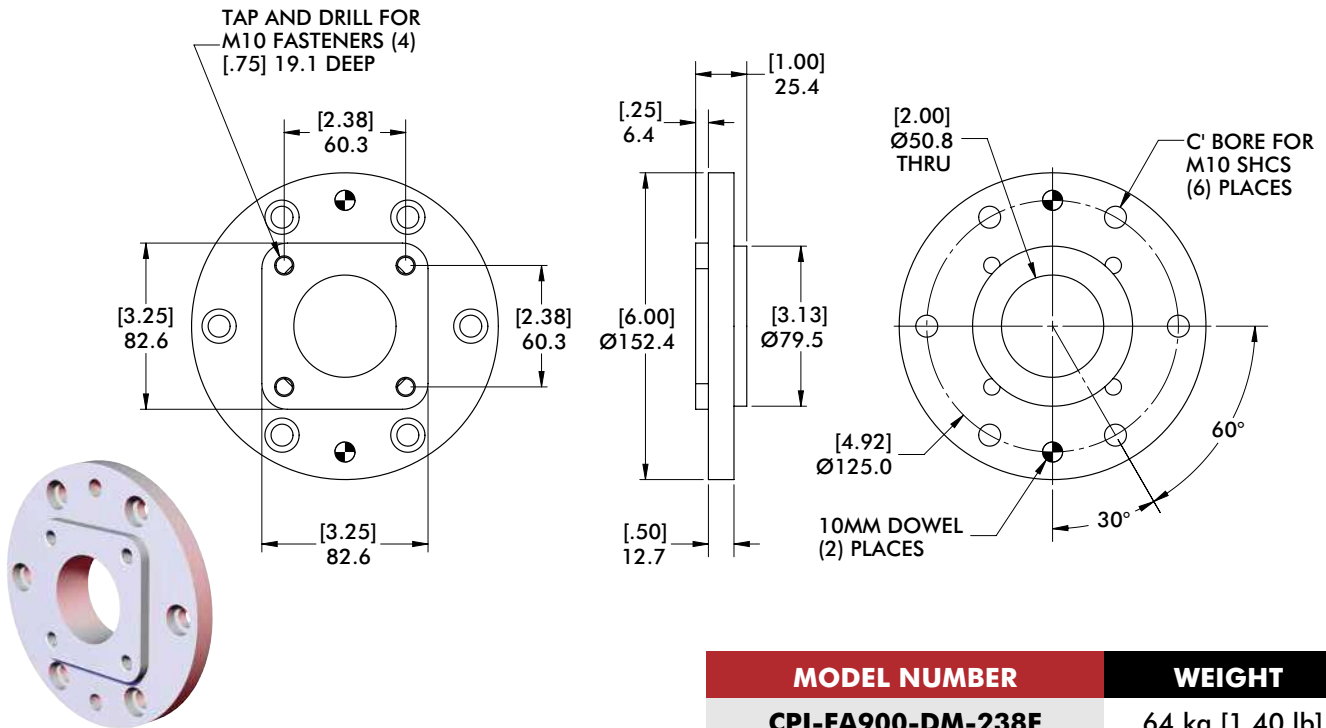

### KW150 Direct Mount Adaptor Plate - Ø92mm Bolt Circle

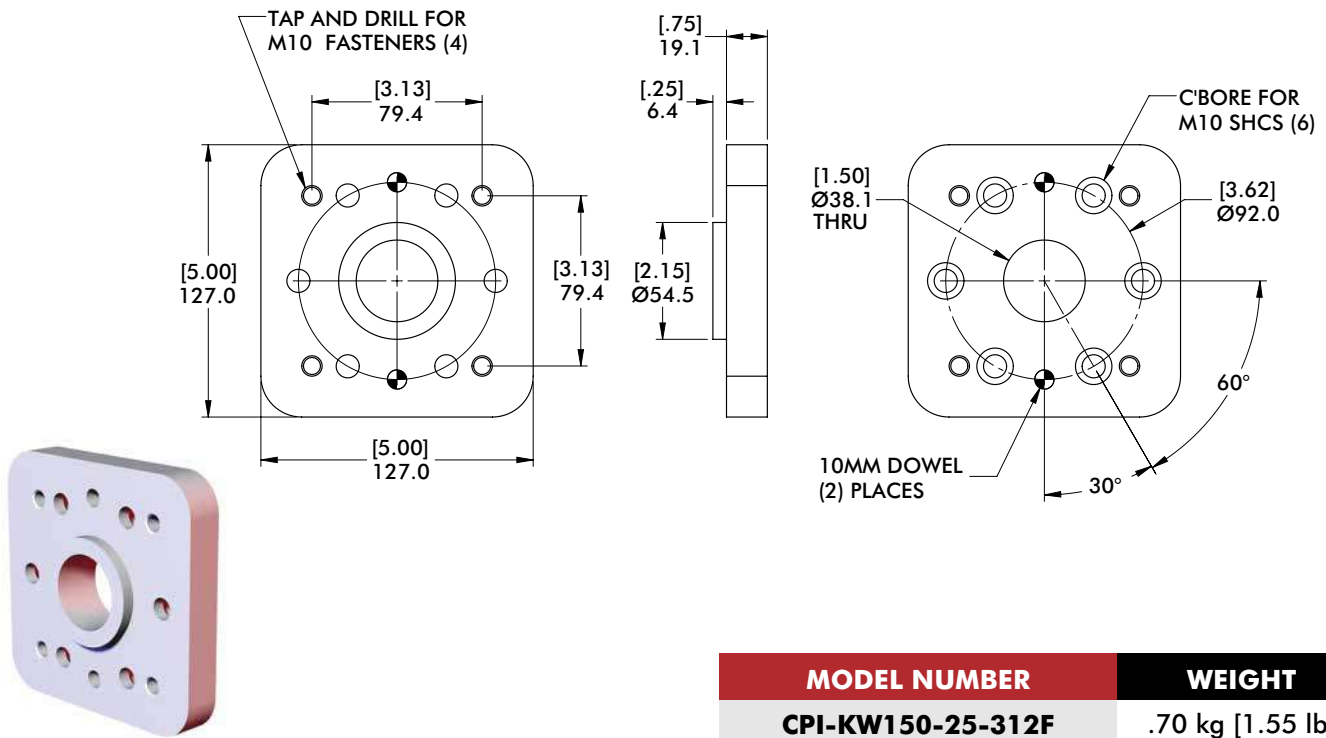

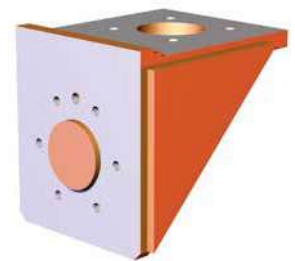
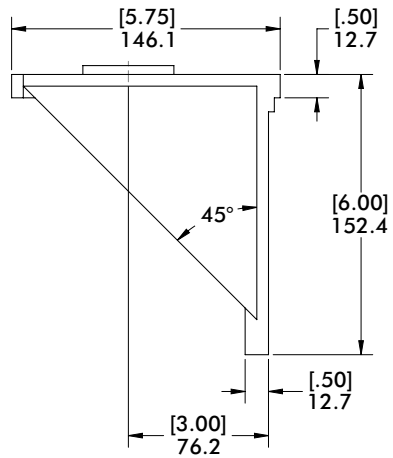
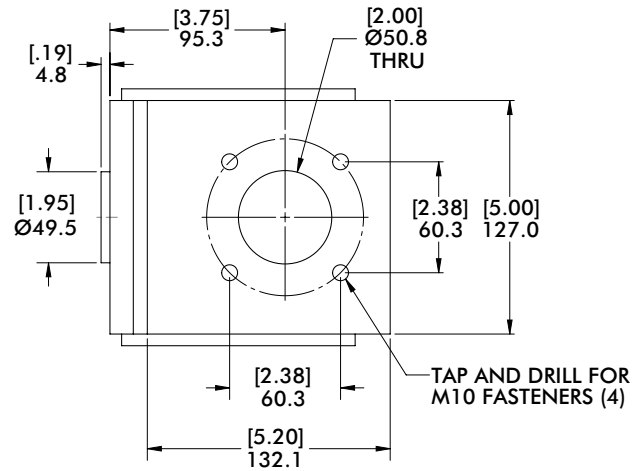
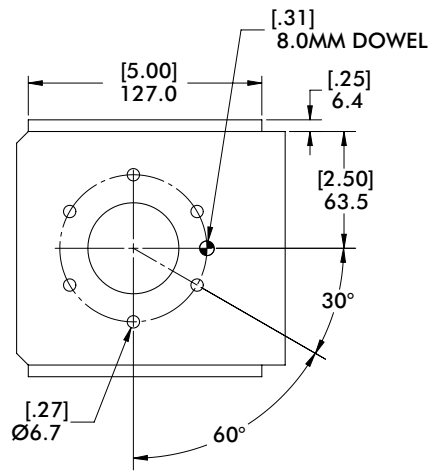

MODEL NUMBER	WEIGHT
CPI-KWFS45N-90-TTN40-A3	4.24 kg [9.34 lb]

# CL-LAN

## Robot Automation Adaptors | Dimensions

Ø125mm Bolt Circle

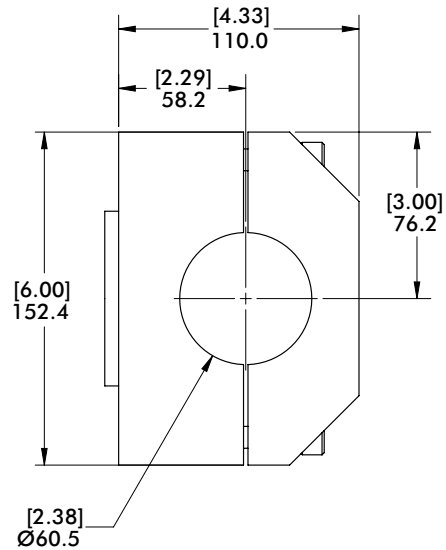
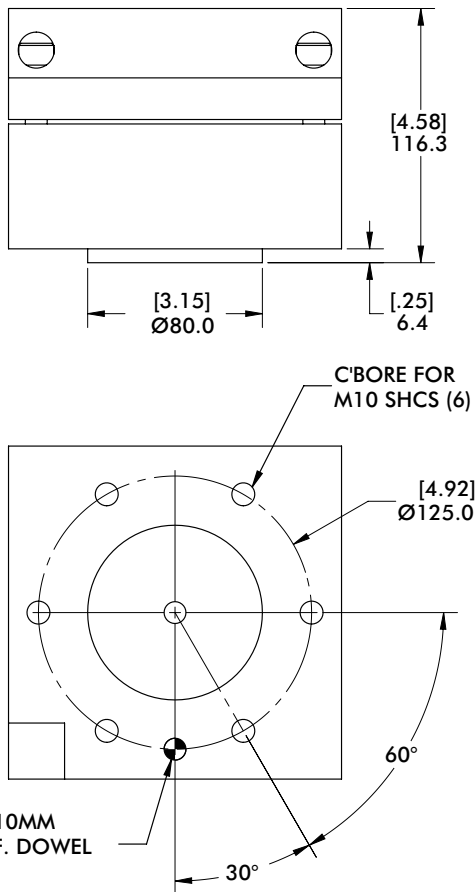
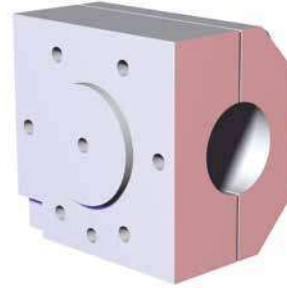
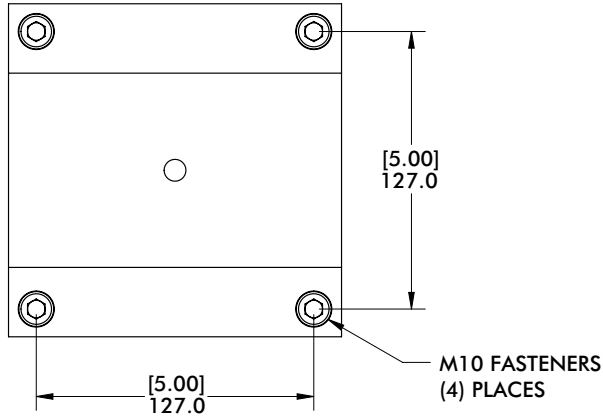

**MODEL NUMBER**

**WEIGHT**

**CPI-CL-LAN-EOL**

5.25 kg [11.58 lb]



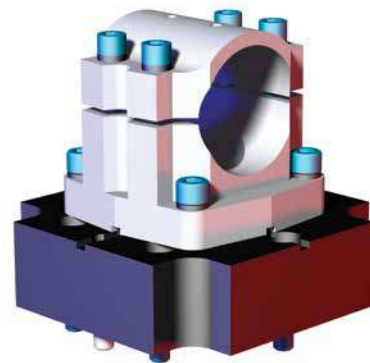
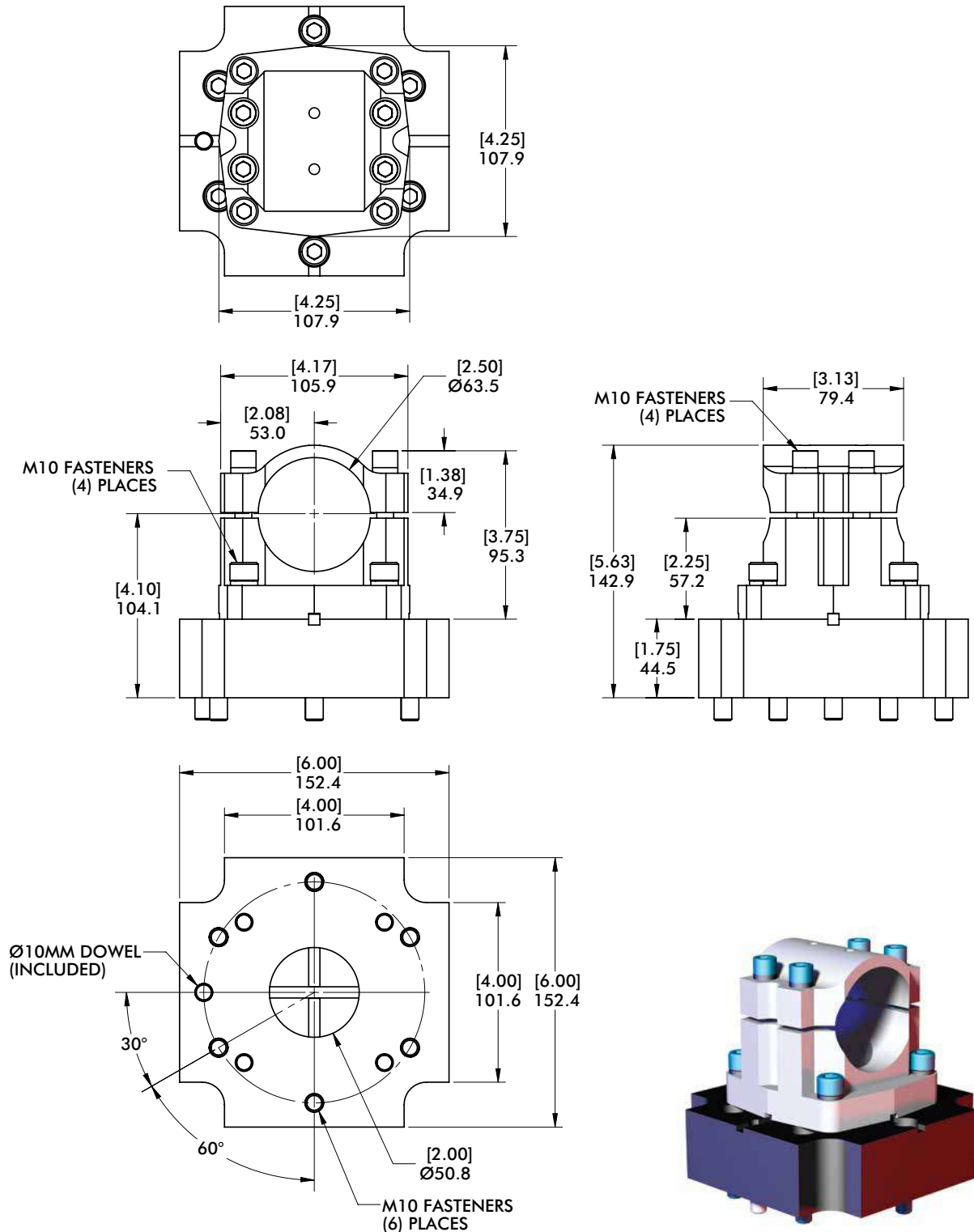

MODEL NUMBER	WEIGHT
CPI-ATI-151-90-WT	3.64 kg [8.03 lb]

# ATI-90

## Robot Automation Adaptors | Dimensions

### Light Duty - Ø125mm Bolt Circle

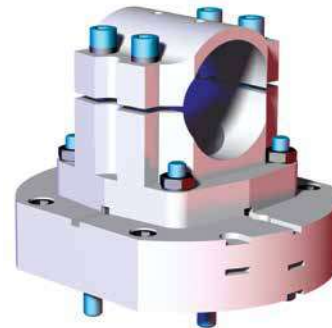
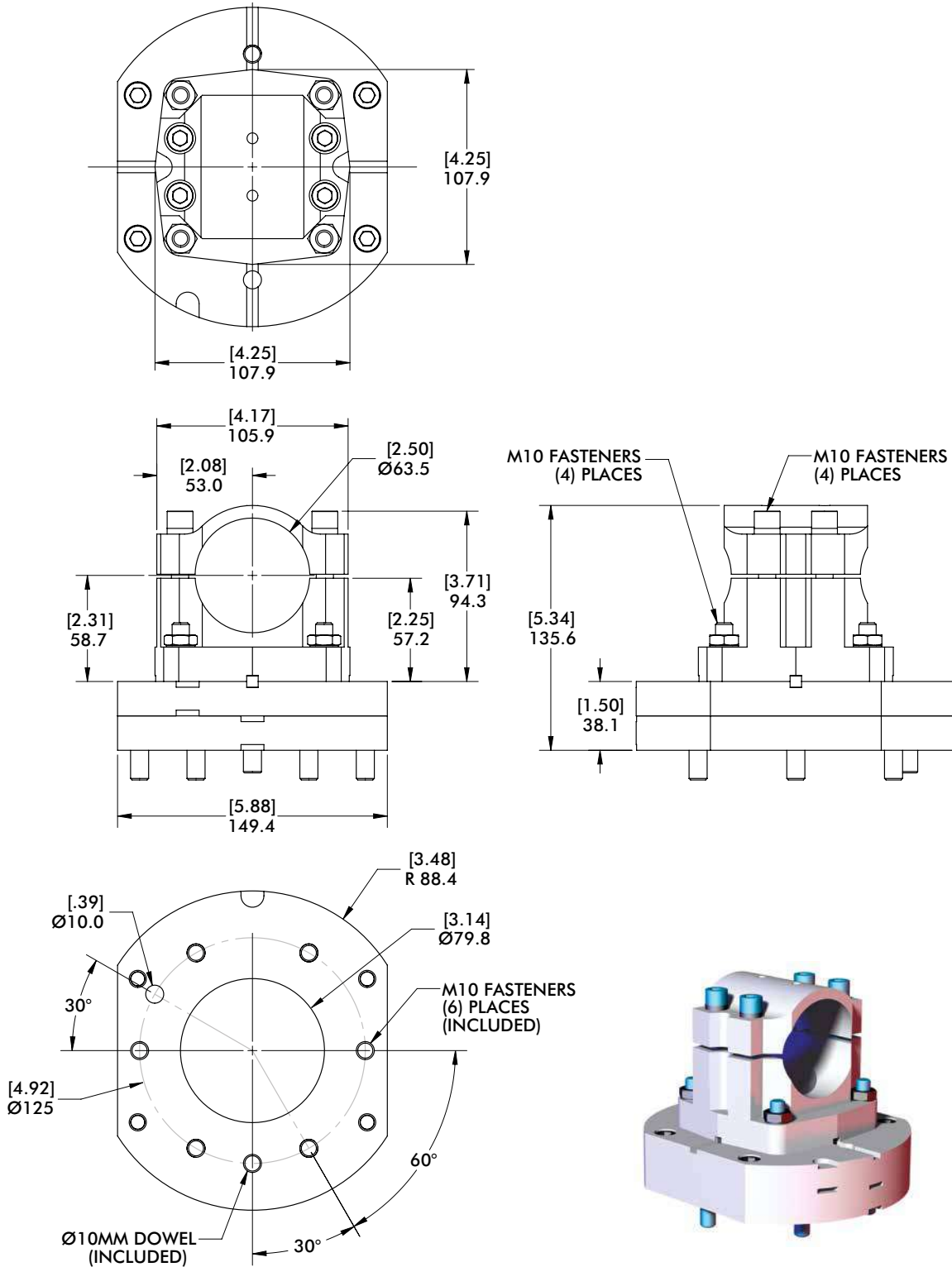

MODEL NUMBER	WEIGHT
CPI-ATI-90	3.55 kg [7.82 lb]

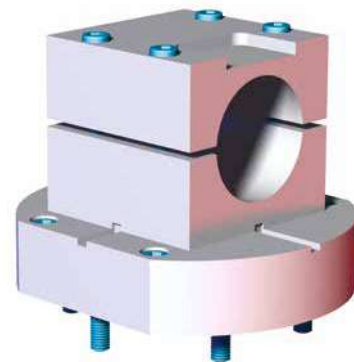
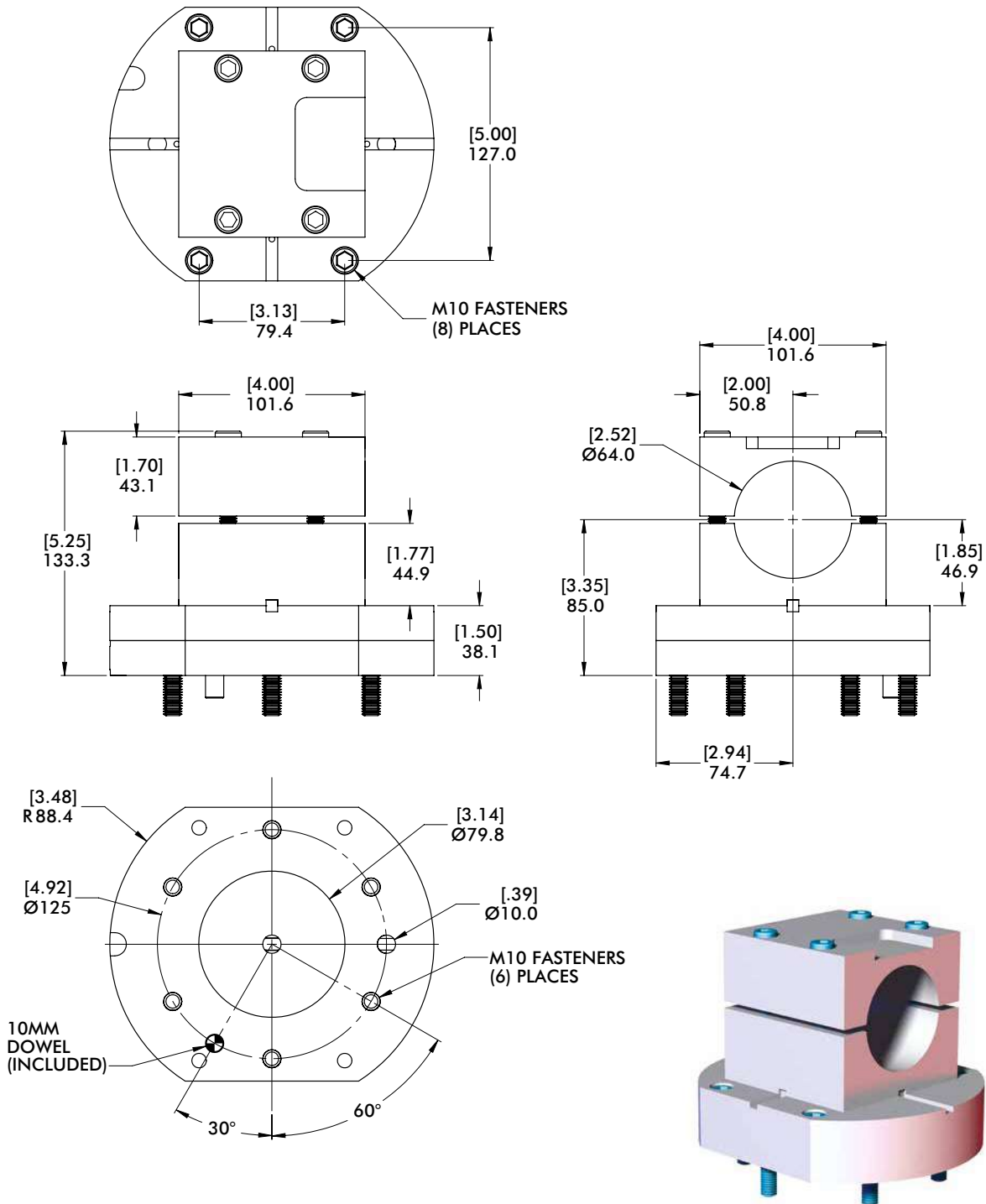

MODEL NUMBER	WEIGHT
CPI-ATI-90-SP	3.64 kg [8.03 lb]

# ATI-201-60

## Robot Automation Adaptors | Dimensions

Ø125mm Bolt Circle

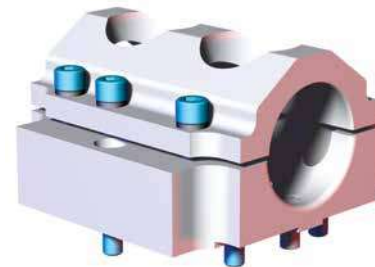
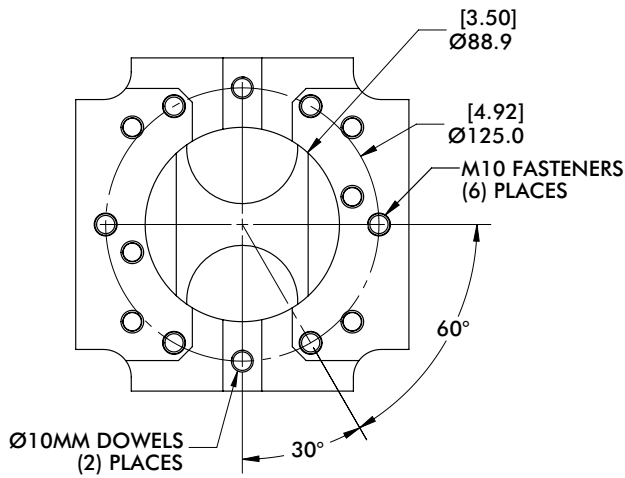
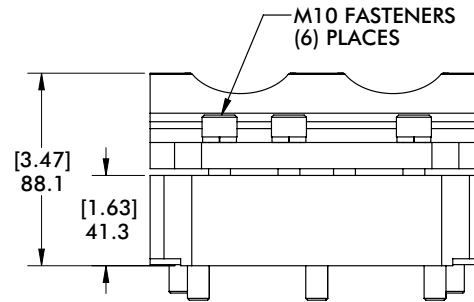
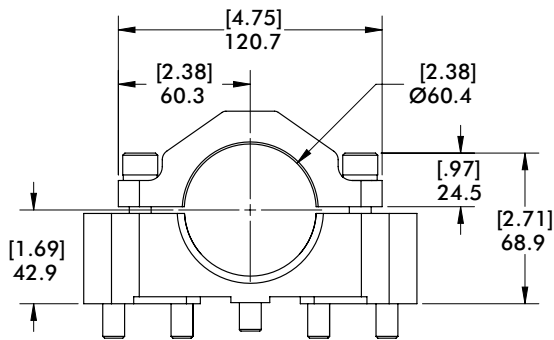
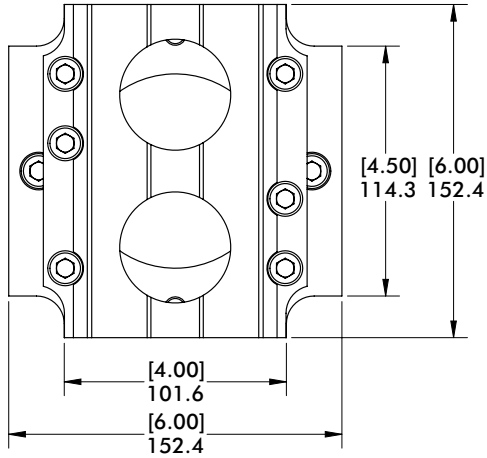

**MODEL NUMBER**

**WEIGHT**

**CPI-ATI-201-60**

**2.29 kg [5.06 lb]**

# ATI-201-XXX-90

Robot Automation Adaptors | Dimensions

Ø125mm Bolt Circle Dowels

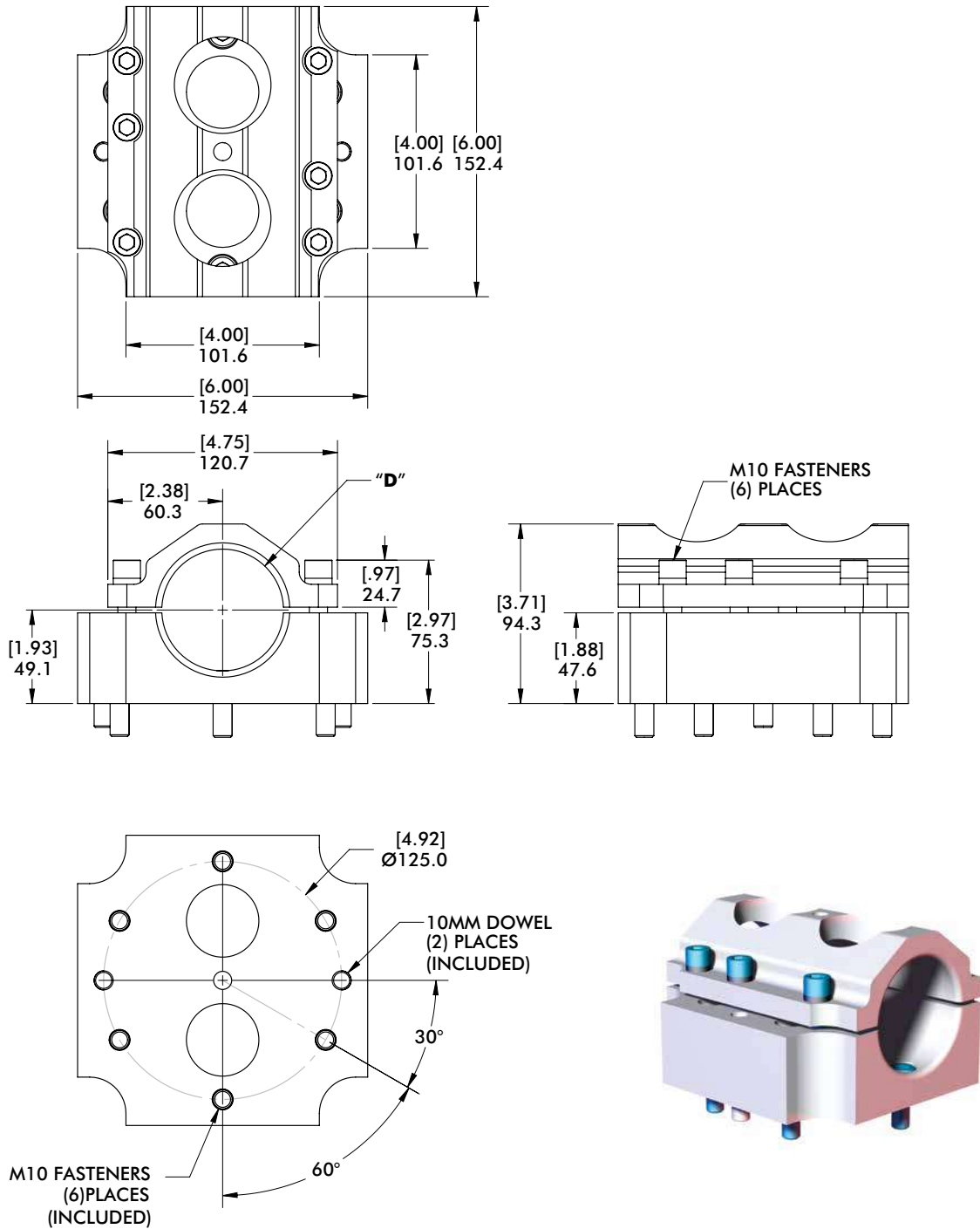

MODEL NUMBER	(Ø) "D"	(Ø) ACTUAL	WEIGHT
CPI-ATI-201-60-90	60mm	60.45±.08 [2.380±.003]	1.27 kg [2.80 lb]
CPI-ATI-201-250-90	2.50"(in)	63.96±.08 [2.518±.003]	1.27 kg [2.80 lb]

# ATI-201-90-HD

## Robot Automation Adaptors | Dimensions

Ø125mm Bolt Circle

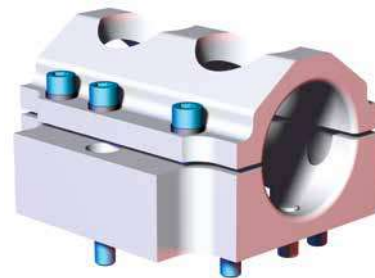
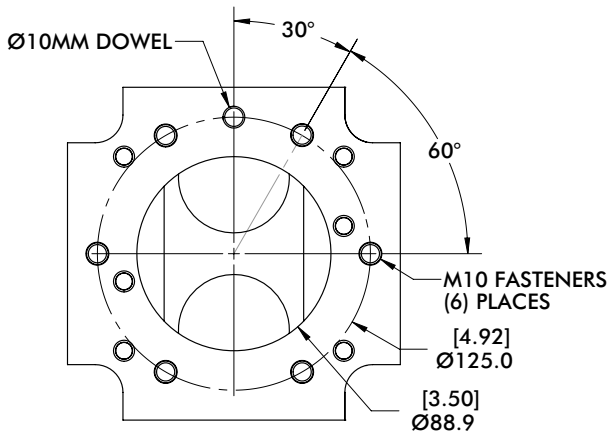
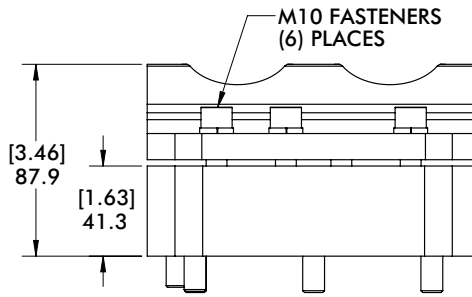
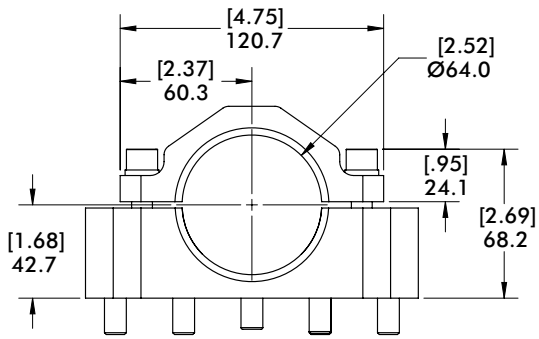
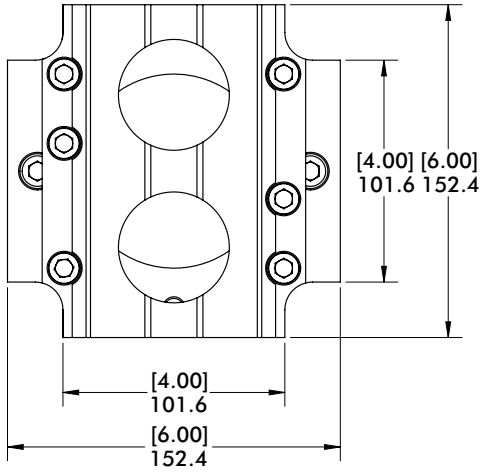

**MODEL NUMBER**

**WEIGHT**

**CPI-ATI-201-90-HD**

**2.17 kg [4.77 lb]**

# ATI-150-90-3HD

Robot Automation Adaptors | Dimensions

Ø125mm Bolt Circle

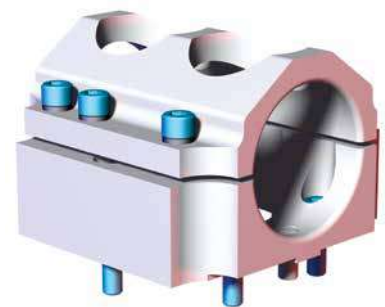
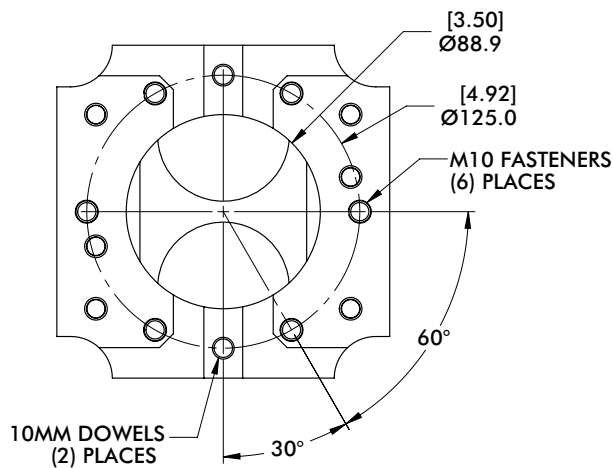
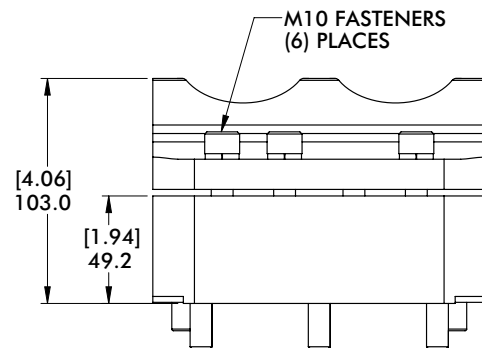
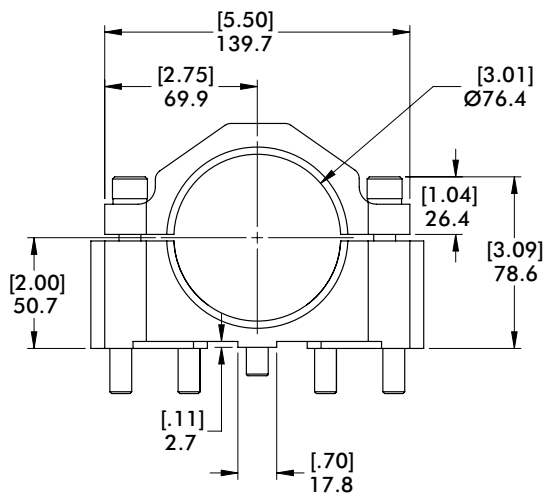
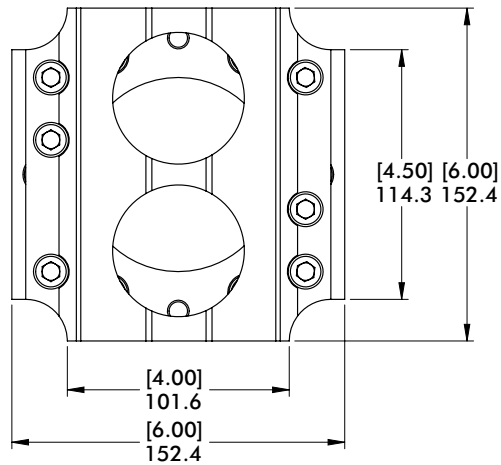

MODEL NUMBER	WEIGHT
CPI-ATI-201-90-3HD	2.50 kg [5.52 lb]

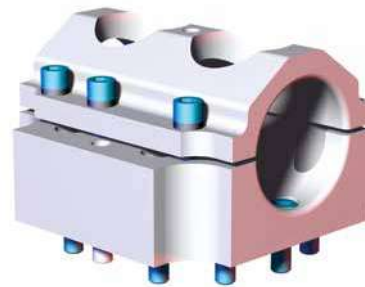
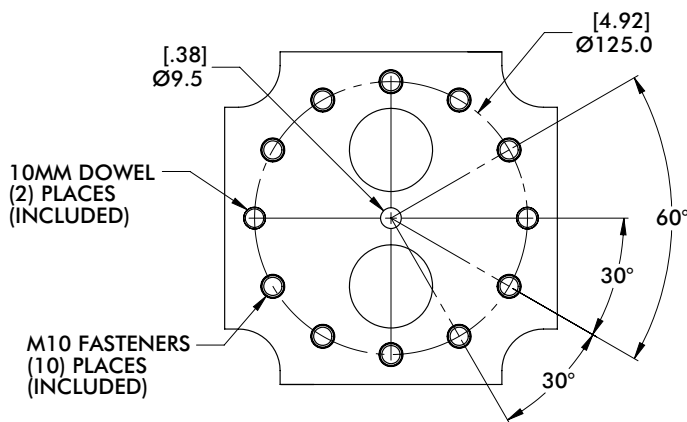
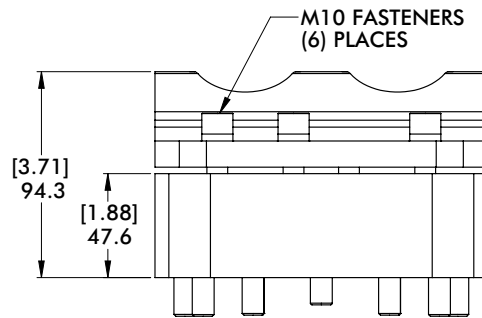
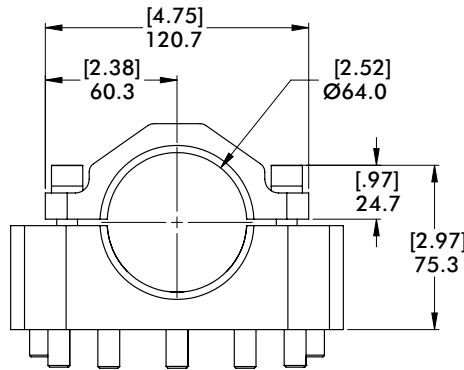
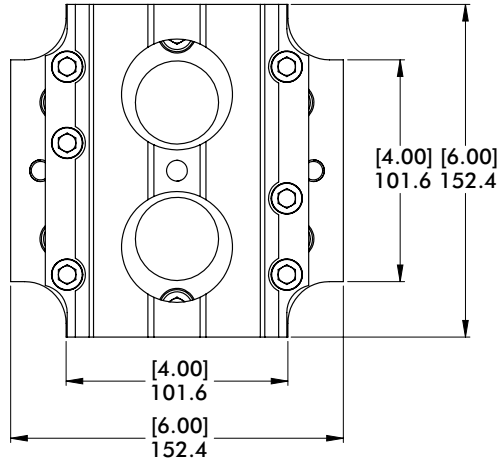

**MODEL NUMBER**

**WEIGHT**

**CPI-ATI-201-250-90-10S**

**2.17 kg [4.77 lb]**



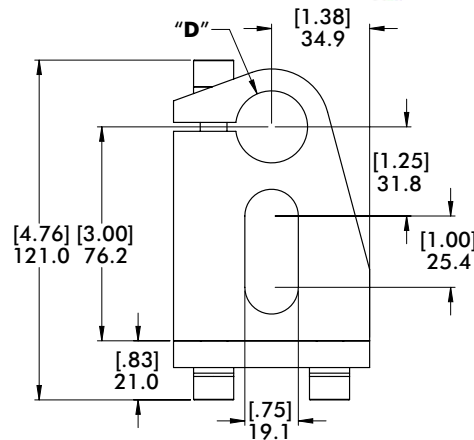
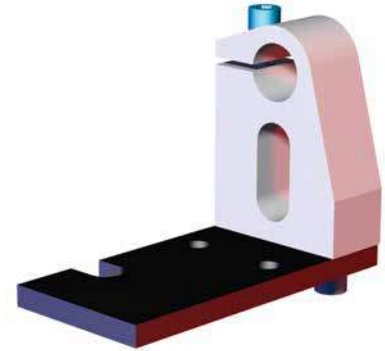
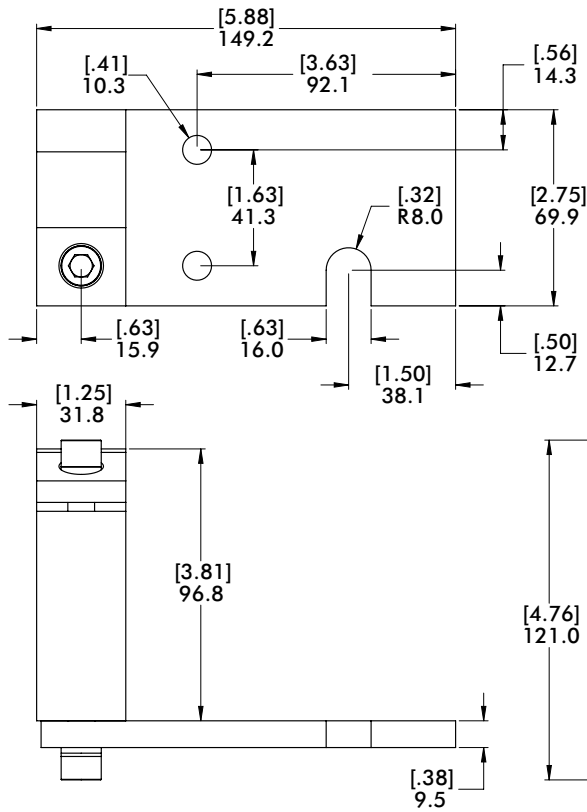

MODEL NUMBER	(Ø) "D"	(Ø) ACTUAL	WEIGHT
CPI-NAV-25-CM	25mm	25.25 <sup>±.08</sup> [0.994 <sup>±.003</sup> ]	[2.60 lb]
CPI-NAV-100-CM	1.00"(in)	25.65 <sup>±.08</sup> [1.010 <sup>±.003</sup> ]	1.18 kg

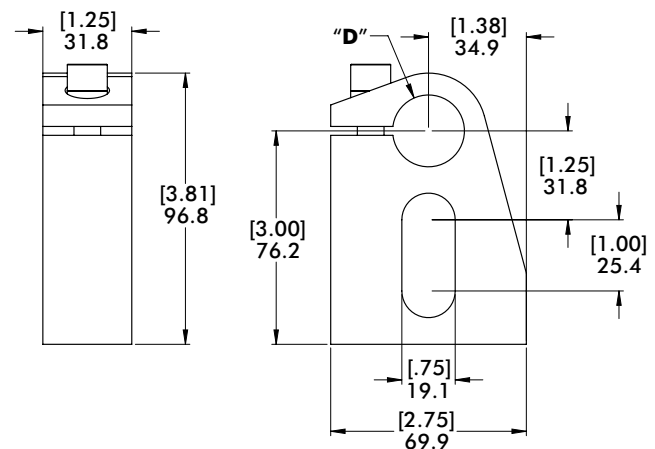

DRILL AND TAP FOR  
M10-1.50 .75 DEEP (2)

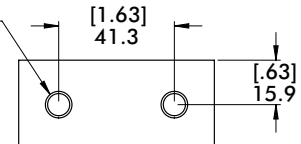

MODEL NUMBER	(Ø) "D"	(Ø) ACTUAL	WEIGHT
CPI-NAV-25-BL	25mm	25.25 <sup>±.08</sup> [0.994 <sup>±.003</sup> ]	[.89 lb]
CPI-NAV-100-BL	1.00"(in)	25.65 <sup>±.08</sup> [1.010 <sup>±.003</sup> ]	.40 kg

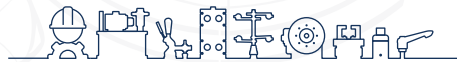

inf @ /CESEHSA.com.mx

