

# Precision Guides

01/28/2025



info@cesehsa.com.mx

cesehsa.com.mx



# Precision Guides

01/28/2025

This catalog is a custom document and the products included is based on your unique selection from portions of complete catalogs that already exist. Please refer to our full catalogs for more information on products not included in this customized document.

## Table of Contents

Precision Guides

PC-PGL-1

## Table of Contents (continued)

# VV85G-150

## Precision Guide | Ordering and Technical Information

**VV85G-150**    **40**    **L8**

Stroke	Description
20	20 mm Stroke
40	40 mm Stroke

Sensor	Description
00	Without Sensing System
L8	PNP Sensor with In-line M12x1 Connector (8EA-146-4-B)
N8	NPN Sensor with In-line M12x1 Connector (8EA-154-4-B)
L9	PNP Sensor with 90° M12x1 Connector (8EA-147-4-B)
N9	NPN Sensor with 90° M12x1 Connector (8EA-155-4-B)
K8	PNP Sensor with M12x1 Cable Connector (8EA-158-4-B)
K9	NPN Sensor with M12x1 Cable Connector (8EA-167-4-B)



Model	Stroke mm [in]	Max. Load Nm [ft-lb] ±0,2 mm [0.008 in.]			Lifting Force N [lbf]	Holding Force N [lbf]	Weight Kg [lbs]	Air Consumption per double stroke at 5 bar [72 psi] dm³ [in³]
		Mtx	Mty	Mtz				
VV85G-15020**	20 [0.79]	[74]	[74]	[37]	500 [112]	[899] 4000	[29.1] 13,2	0,7 [42.7]
VV85G-15040**	40 [1.57]	100	100	50				1,1 [67.1]

# VV85G-150

## Precision Guide | Dimensions

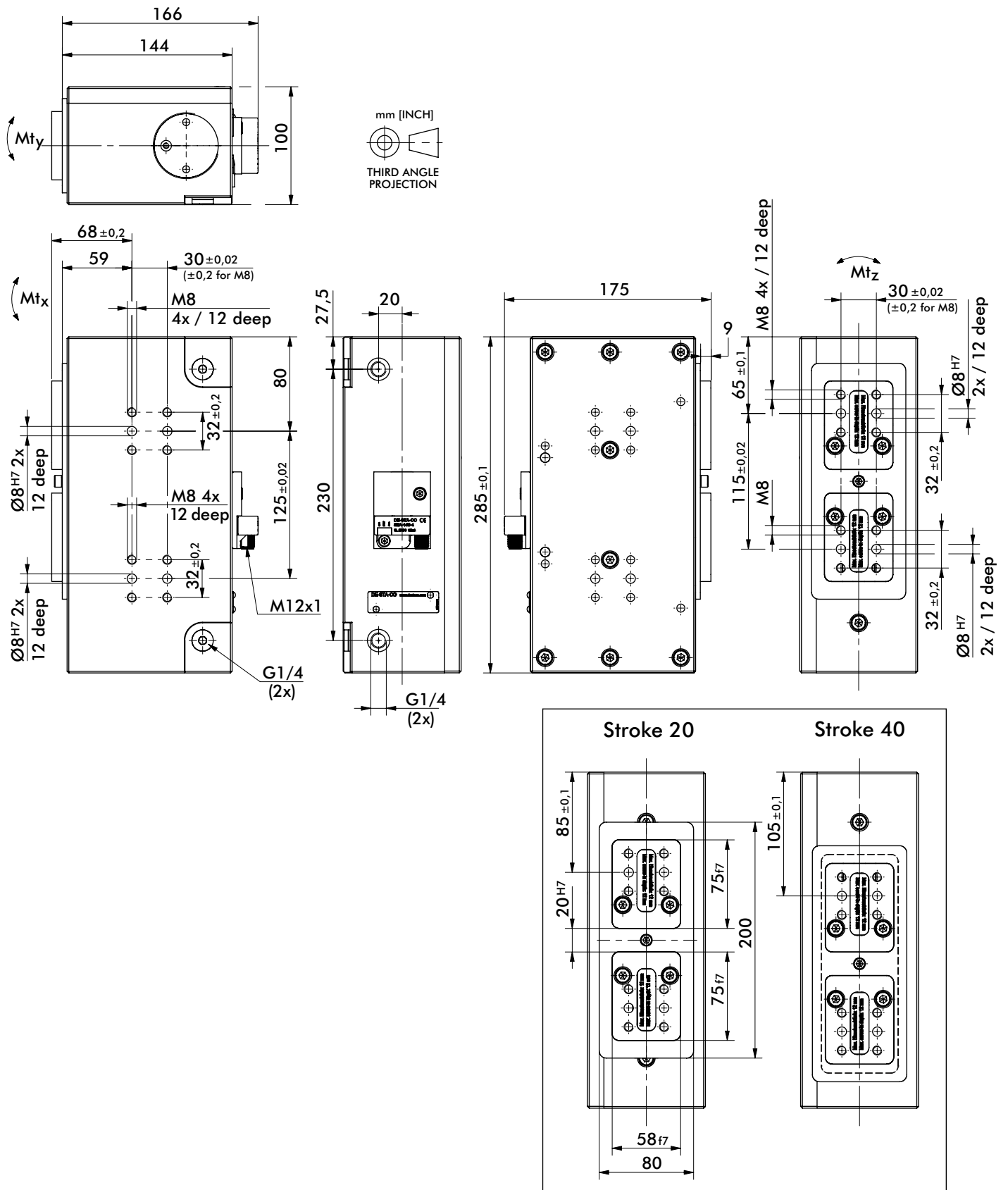

Operation with oil-free air is permissible

# VV85G-150

## Precision Guide | Dimensions and Technical Specifications

### L8, N8 Inductive Sensing System

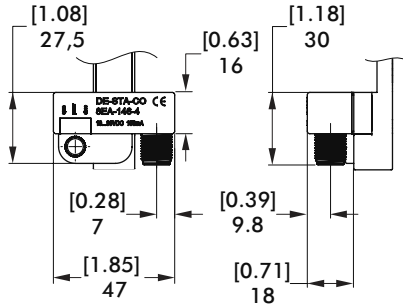

### L9, N9 Inductive Sensing System with 90° Connector

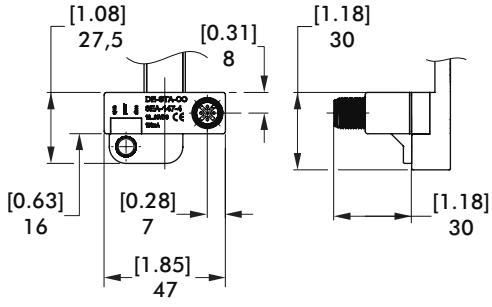

### K8, K9 Inductive Sensing System with Pigtail Connector

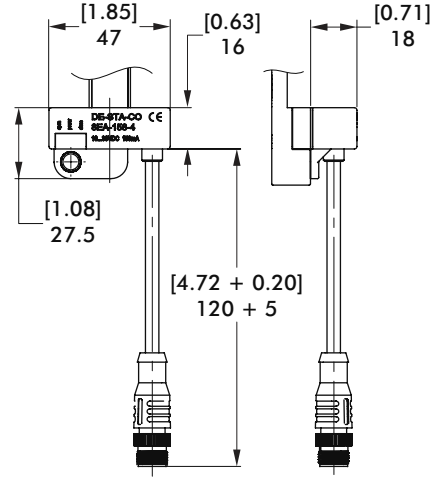

## Inductive Sensor Wiring Diagram

Sensing system immune to interference from AC / DC arc welding.

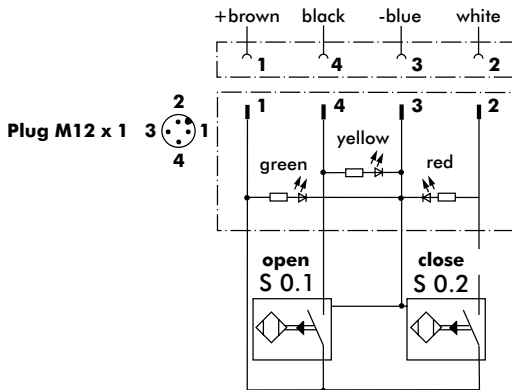

## Sensor Cable Accessories

Sensor Cables (1 connector & 5m cable)	Order no.
M12x1 connector, straight, 5-pin	<b>8EL-002-1</b>
M12x1 connector, 90° angular, 4-pin	<b>8EL-003-1</b>

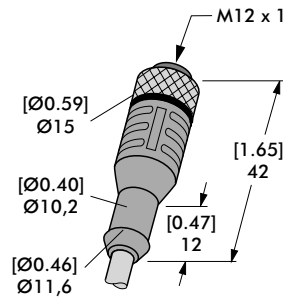

**Straight Cable**  
8EL-002-1

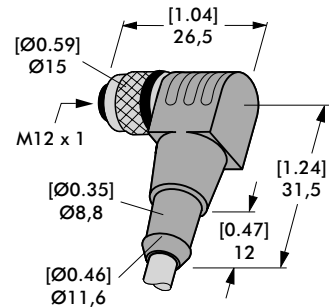

**Angular Cable**  
8EL-003-1

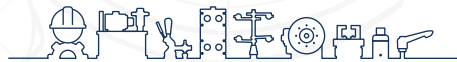

inf @ /CESEHSA.com.mx

