

# Pneumatic Pivot Units

01/28/2025



[info@cesehsa.com.mx](mailto:info@cesehsa.com.mx)

[cesehsa.com.mx](http://cesehsa.com.mx)



# Pneumatic Pivot Units

01/28/2025

This catalog is a custom document and the products included is based on your unique selection from portions of complete catalogs that already exist. Please refer to our full catalogs for more information on products not included in this customized document.

## Table of Contents

Pneumatic Pivot Units

PC-PVT-1

# Pneumatic Pivot Units

01/28/2025

## Table of Contents (continued)



# RCM/RFM

## Pneumatic Pivot Units | Ordering Information

**RFM** | **125** | **.2** | **129** | **V/LS** | **PX** | **P** | **N** | **X**

**Base** Description  
**RCM** Standard  
**RFM** Integrated Braking

Cylinder	Description
100	100 mm Bore
125	125 mm Bore
160	160 mm Bore
200	200 mm Bore

Opening Angles			
100		125, 160, 200	
O	O/LS	V	V/LS
N/A		15°	
29°		30°	
45°		43°	
61°		61°	
77°		76°	
92°	N/A	92°	
104°	N/A	104°	
121°	N/A	121°	
		91°	N/A
		107°	N/A
		N/A	129°

Opening angles are easily field adjustable.

**Saddle Orientation**  
**O**  
**V**  
**O/LS**  
**V/LS**

**Description**  
 Horizontal  
 Vertical  
 Inverted Horizontal  
 Inverted Vertical

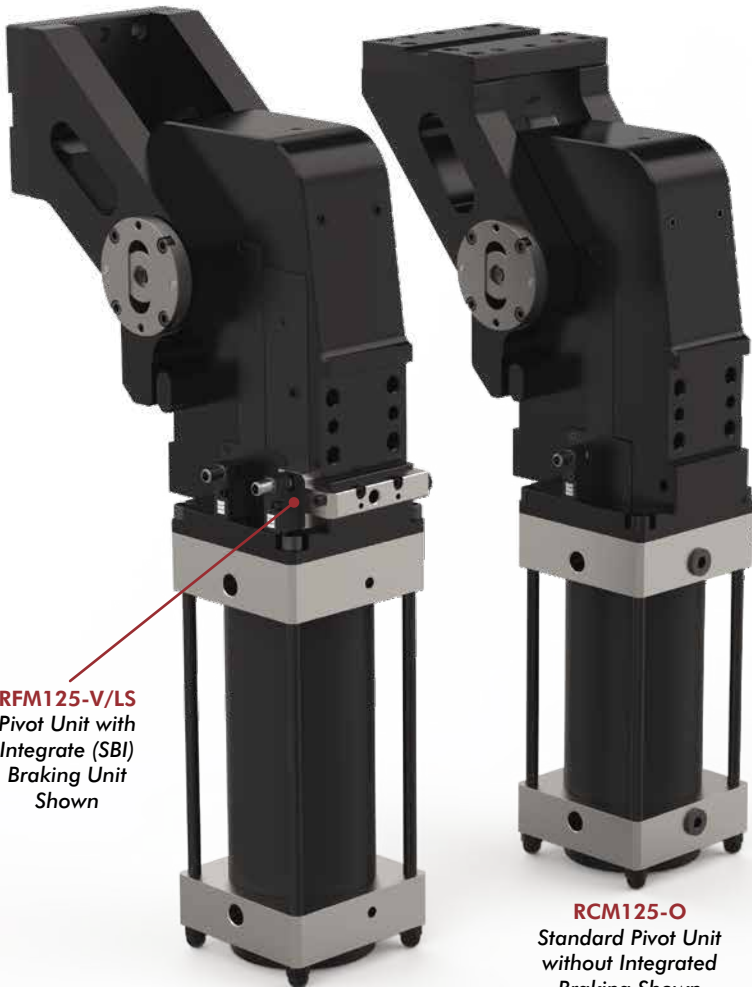

**RFM125-V/LS**  
 Pivot Unit with  
 Integrate (SBI)  
 Braking Unit  
 Shown

**RCM125-O**  
 Standard Pivot Unit  
 without Integrated  
 Braking Shown

### RCM Series



RCM100-O RCM125-O RCM160-O RCM200-O

### RFM Series



RFM100-V RFM125-V RFM160-V RFM200-V

Ports	Description
N	NPT Ports
G	G Port

Proximity Switch Type	Description
0	No Proximity Switch
P	Pepperl+Fuchs Proximity Switch

Proximity Switch Location	Description
P0	No Proximity Switch
PX	Proximity Switch on Left-Side
PY	Proximity Switch on Right-Side

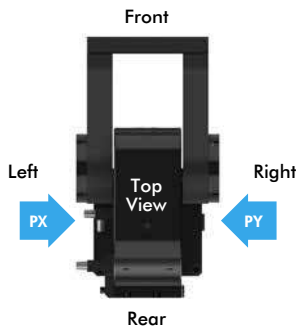

Cylinder Orientation	Description
X	Left-Facing Airport
Y	Right-Facing Airport
W	Front-Facing Airport
Z	Rear-Facing Airport

<span style="color: green;">■</span>	Air Port
<span style="color: lightgreen;">■</span>	Air Ports Plugged
<span style="color: purple;">■</span>	Cushion Adjustment

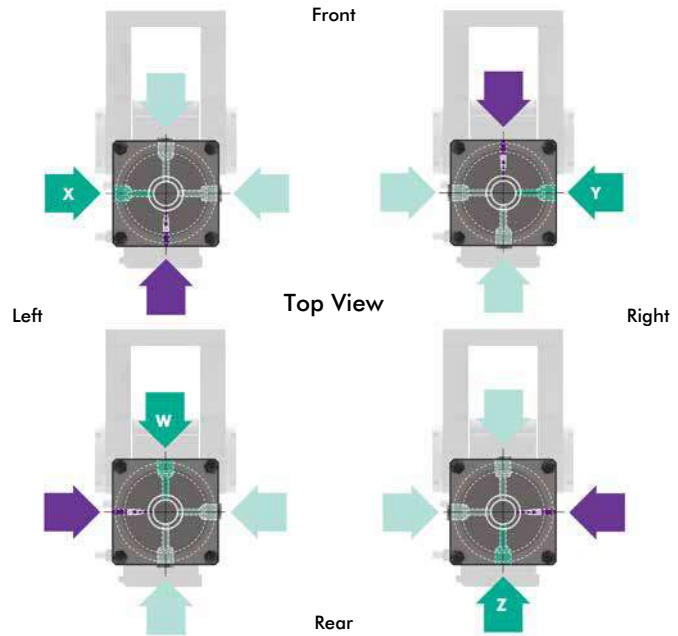

### Cylinder Operating Principle

The RCM/RCM series pivot units uses a combined pneumatic and hydraulic cylinder, using a hydraulic/pneumatic piston rod within the standard pneumatic cylinder structure. This will allow for standard pneumatic operation while providing shock absorption or dampening in heavy duty applications during opening and closing positioning.

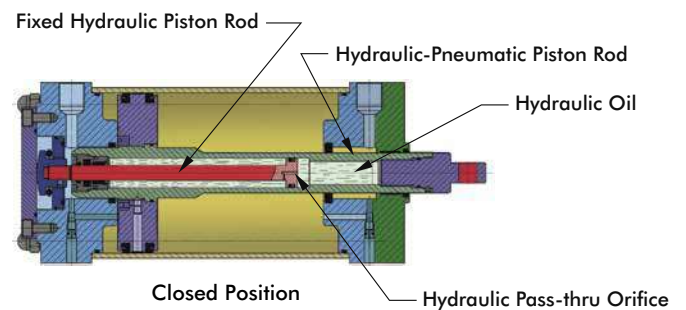
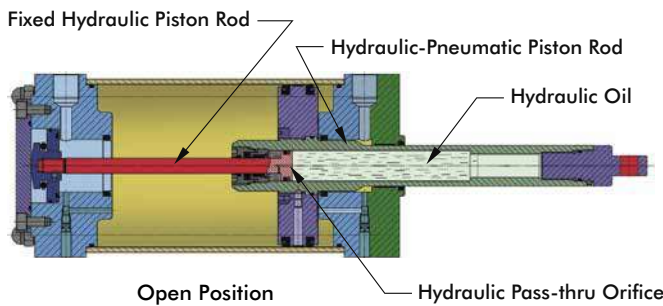

Specifications	Units	100	125	160	200
Max Torque by Load [5 bar] Opening Angle $\leq 92^\circ$	Nm [ft-lbs]	150 [111]	240 [171]	410 [302]	660 [487]
Max Torque by Load [5 bar] Opening Angle $> 92^\circ / \leq 121^\circ$	Nm [ft-lbs]	110 [81]	180 [133]	300 [221]	480 [354]
Max Torque by Load [5 bar] Opening angle $> 121^\circ$	Nm [ft-lbs]	55 [41]	65 [48]	100 [74]	175 [129]
Holding Moment	Nm [ft-lbs]	2000 [1475]	3500 [2581]		
RCM Weight	kg [lbs]	~27 [60]	~61 [134]	~74 [163]	~81 [178]
RFM Weight	kg [lbs]	~30 [66]	~64 [141]	~77 [169]	~84 [185]

# RCM/RFM

## Pneumatic Pivot Units | Dimensions

### RCM/RFM100 Vertical "V" Orientation Pivot Dimensions

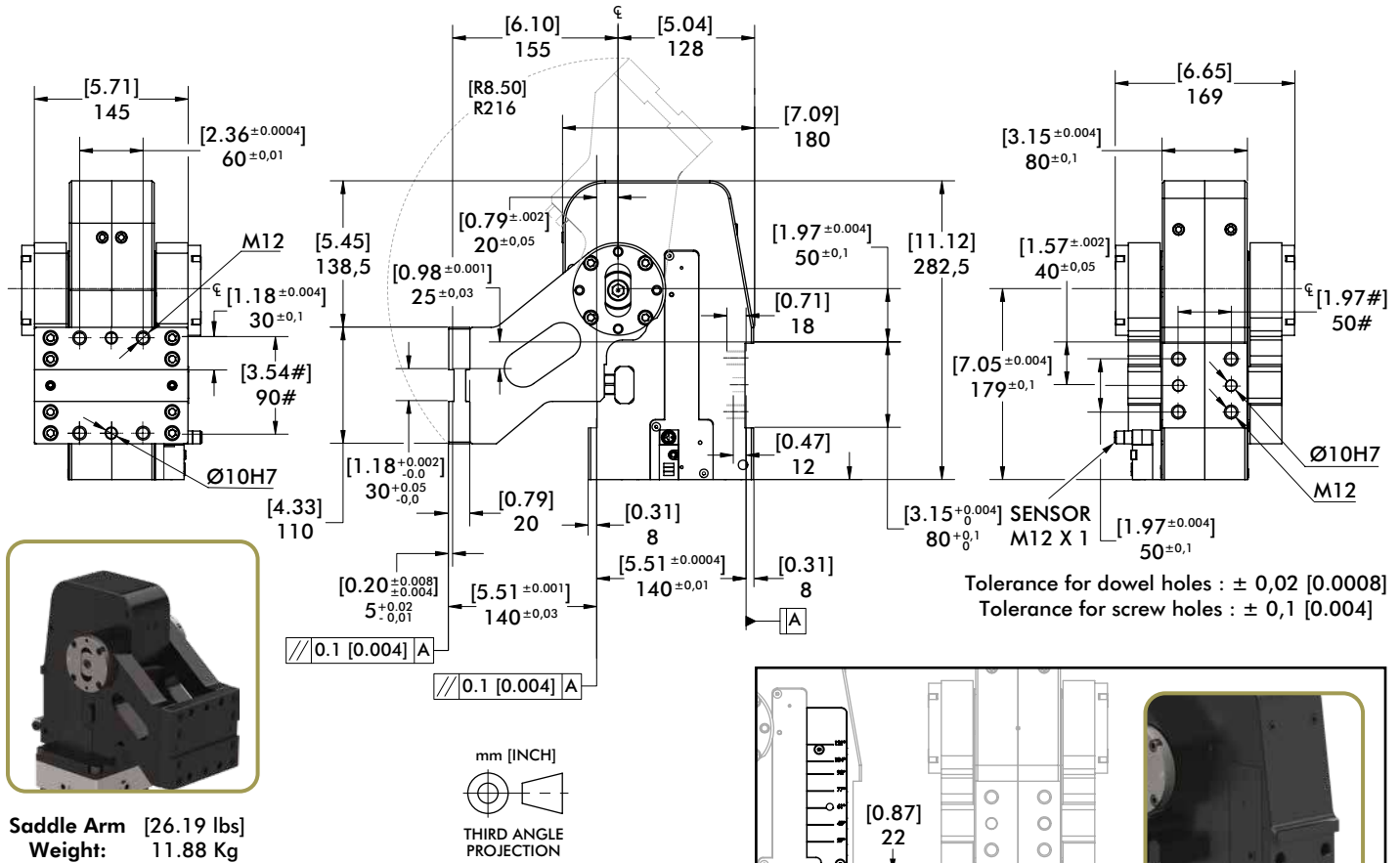

### RCM/RFM100 Vertical "V/LS" Orientation Pivot Dimensions



**Saddle Arm** [27.38 lbs]  
**Weight:** 12.42 Kg

mm [INCH]  
 THIRD ANGLE PROJECTION

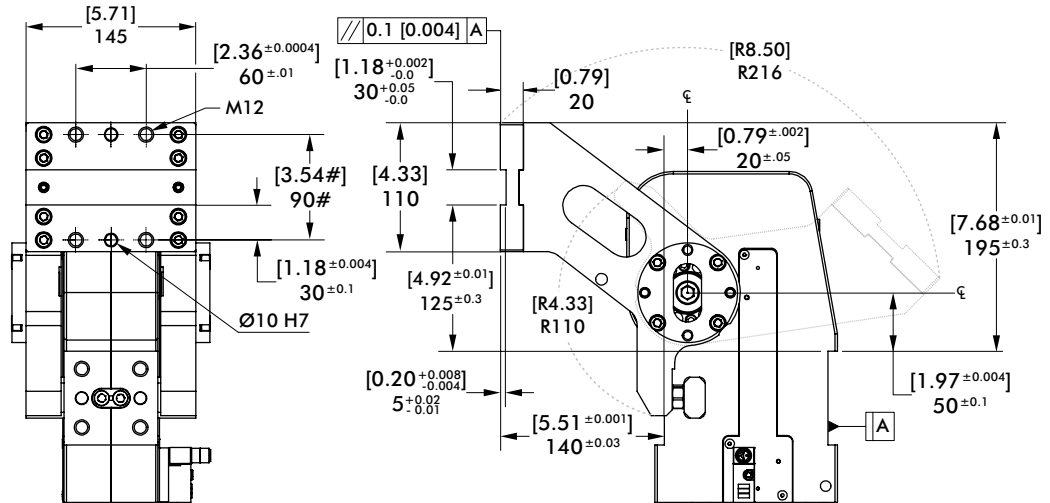

Tolerance for dowel holes : ± 0,02 [0.0008]  
 Tolerance for screw holes : ± 0,1 [0.004]

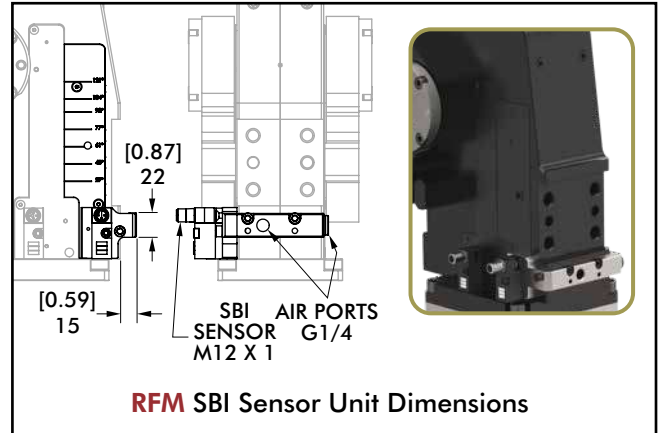

### RCM/RFM100 Horizontal "O" Orientation Pivot Dimensions

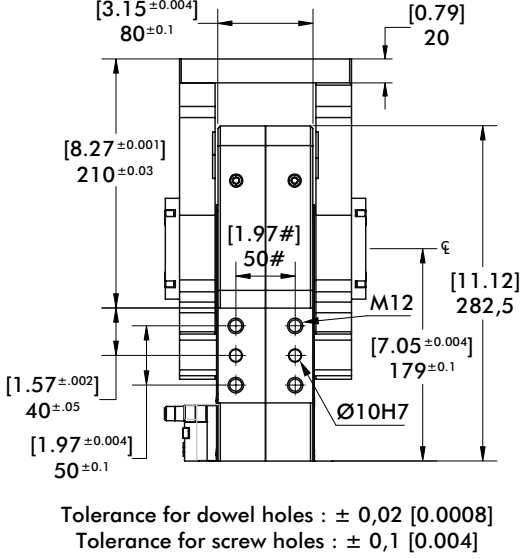
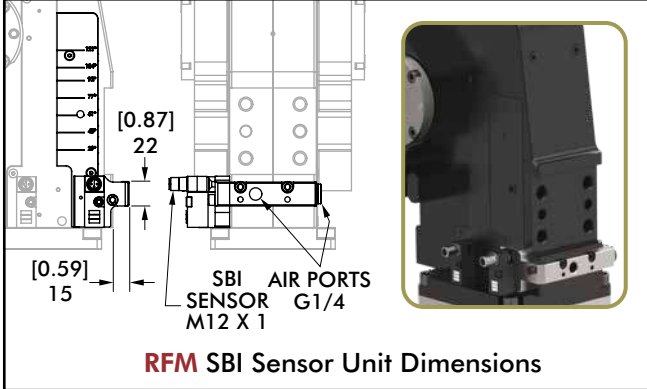
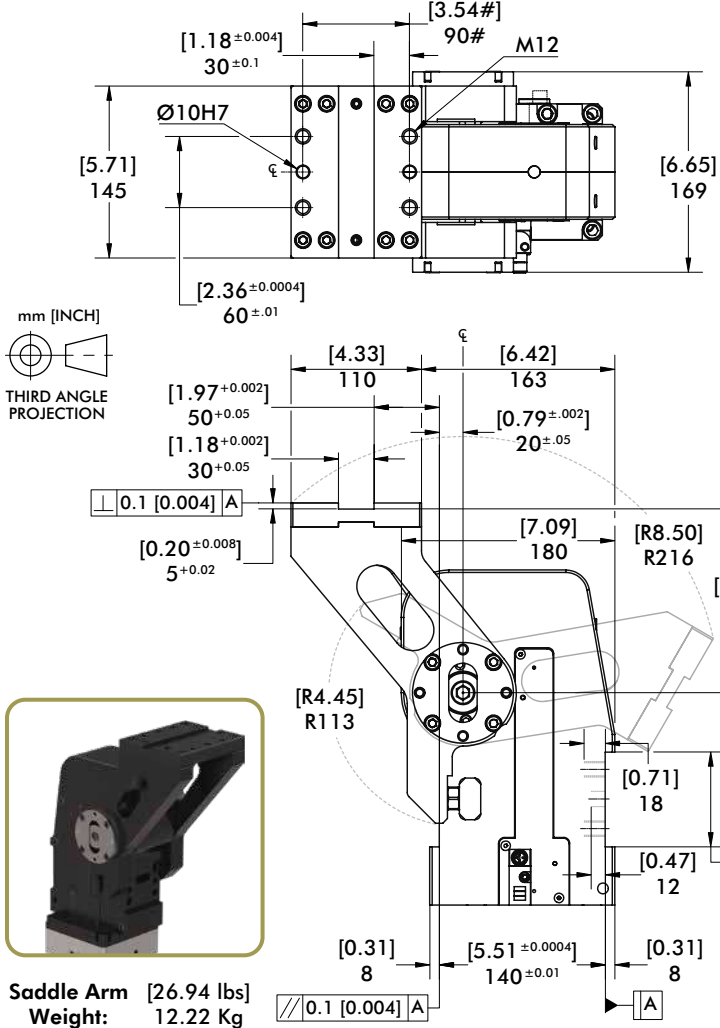

### RCM/RFM100 Horizontal "O/LS" Orientation Pivot Dimensions

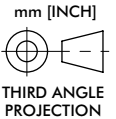
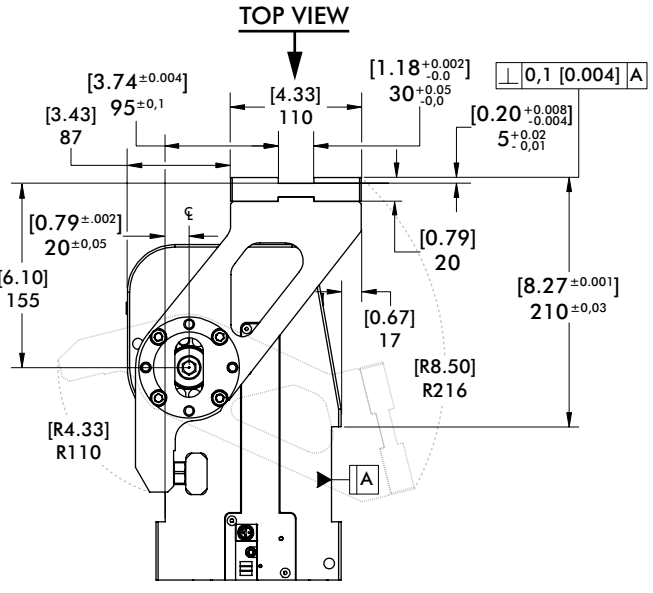
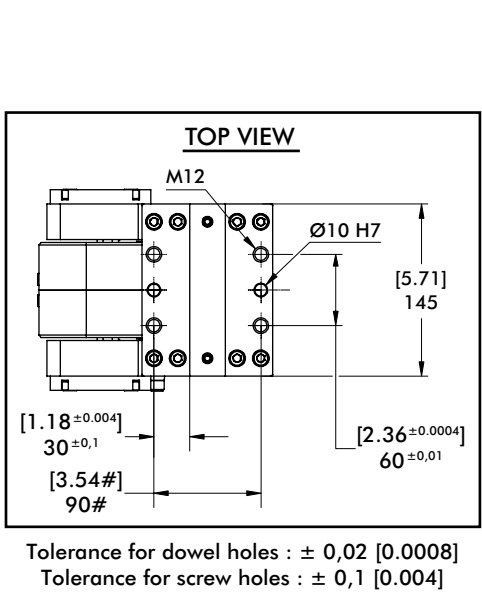

# RCM/RFM

## Pneumatic Pivot Units | Dimensions

### RCM/RFM125, 160, 200 Vertical "V" Orientation Pivot Unit and Saddle Dimensions

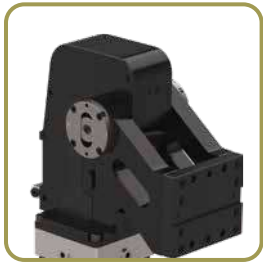
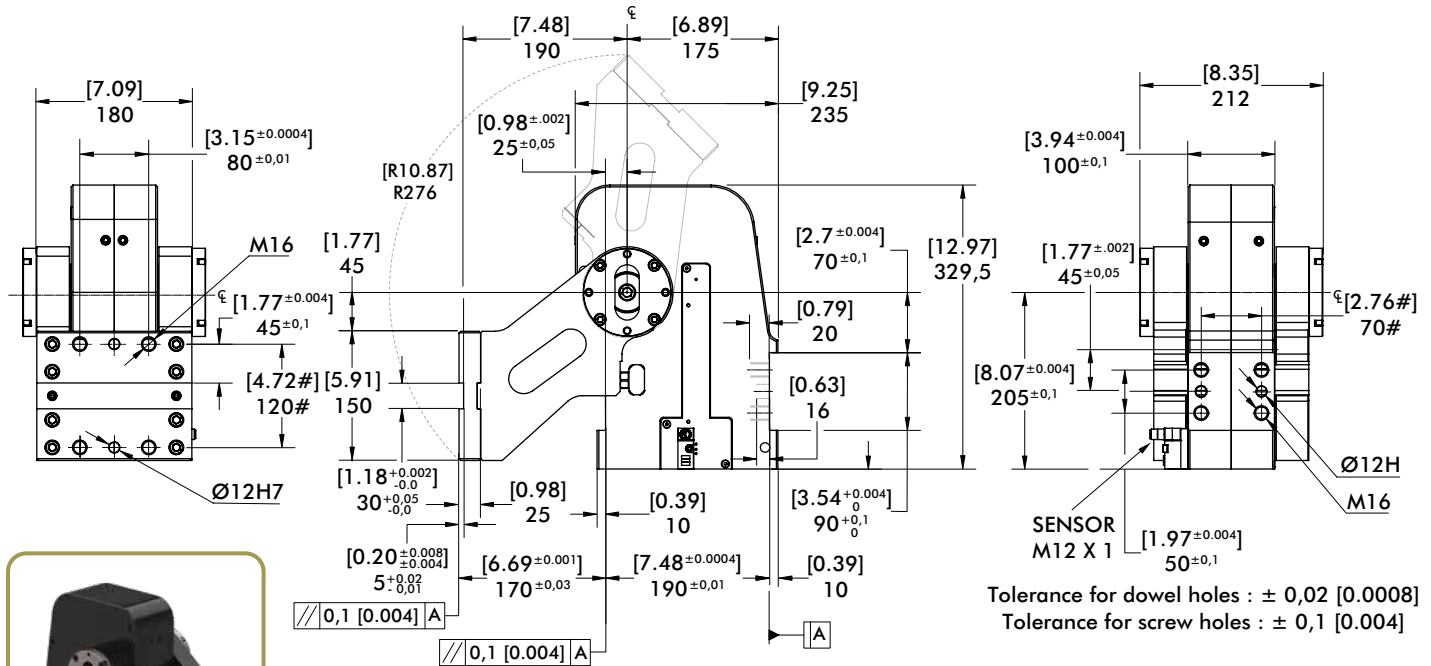

**Saddle Arm** [52.21 lbs]  
**Weight:** 23.68 Kg

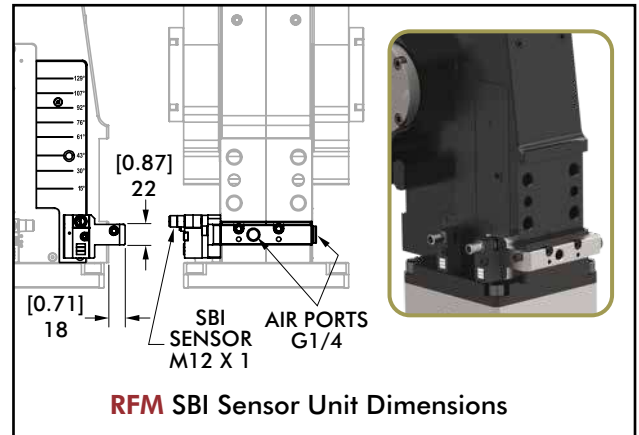
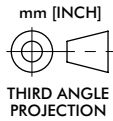

### RCM/RFM125, 160, 200 Vertical "V/LS" Orientation Saddle Dimensions



**Saddle Arm** [55.23 lbs]  
**Weight:** 25.05 Kg

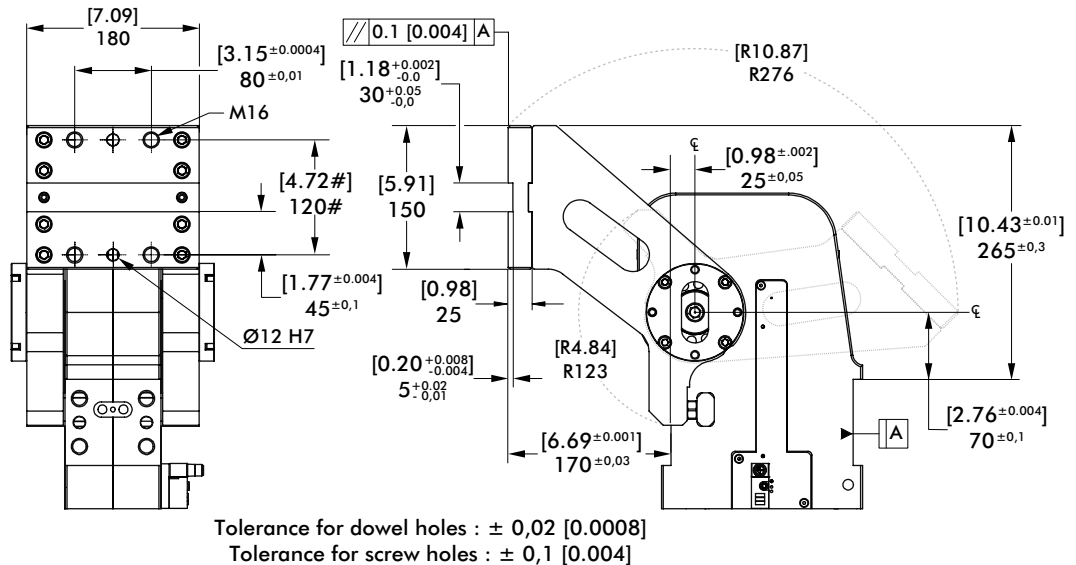
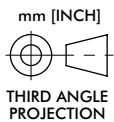



### RCM/RFM125, 160, 200 Horizontal "O" Orientation Pivot Unit and Saddle Dimensions

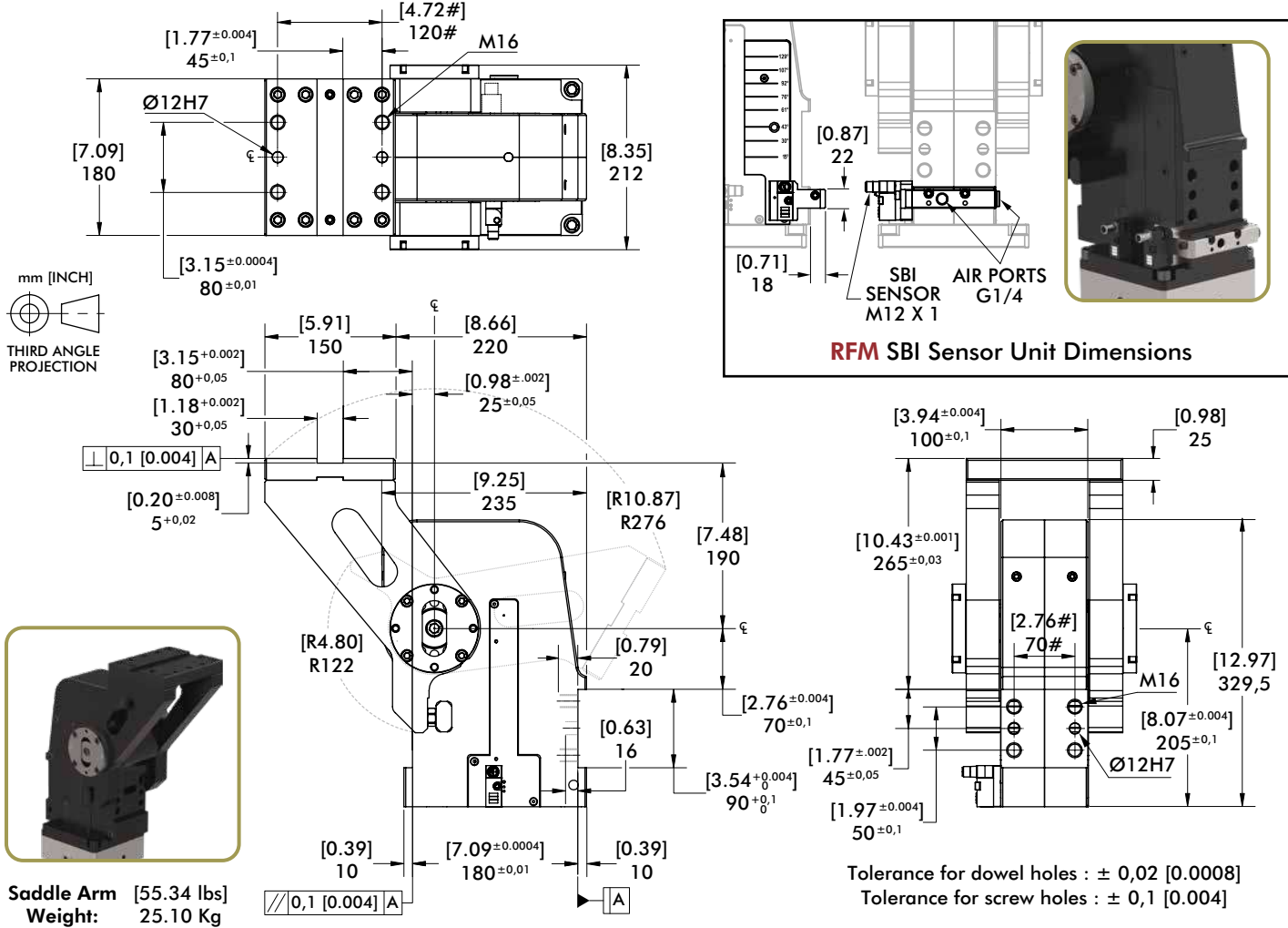

### RCM/RFM125, 160, 200 Horizontal "O/LS" Orientation Saddle Dimensions

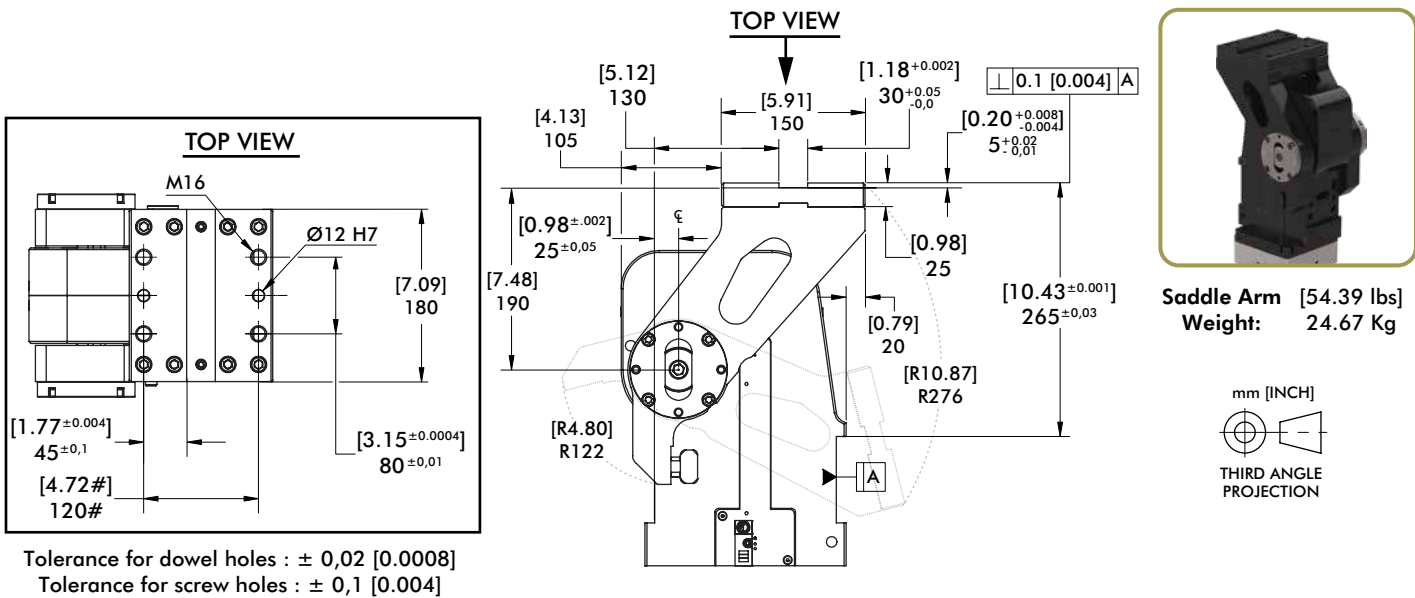

# RCM/RFM

## Pneumatic Pivot Units | Cylinder Dimensions

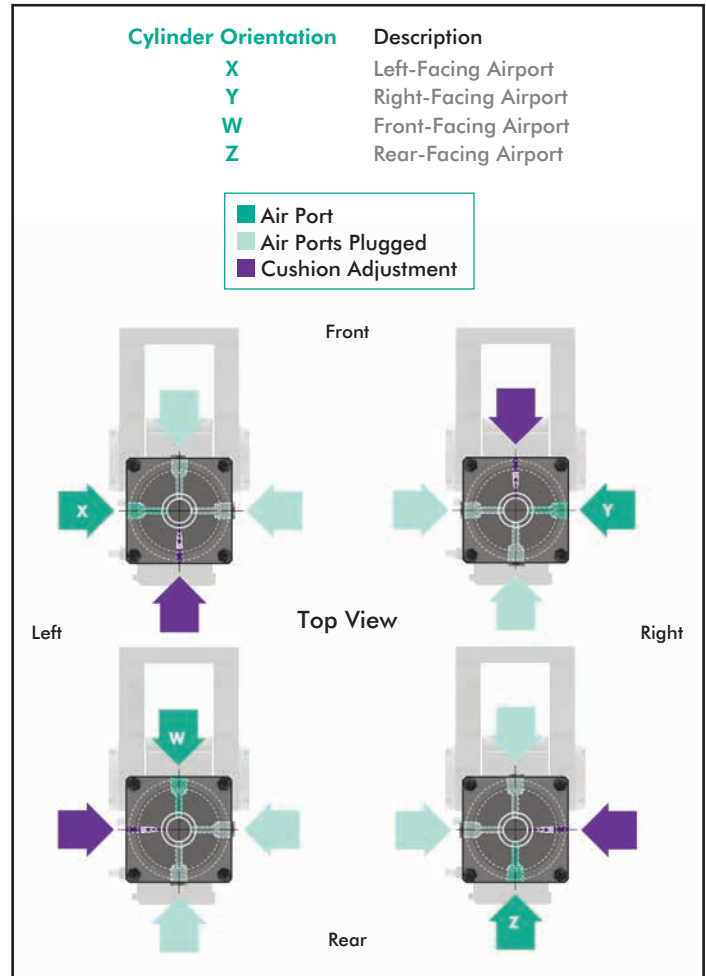
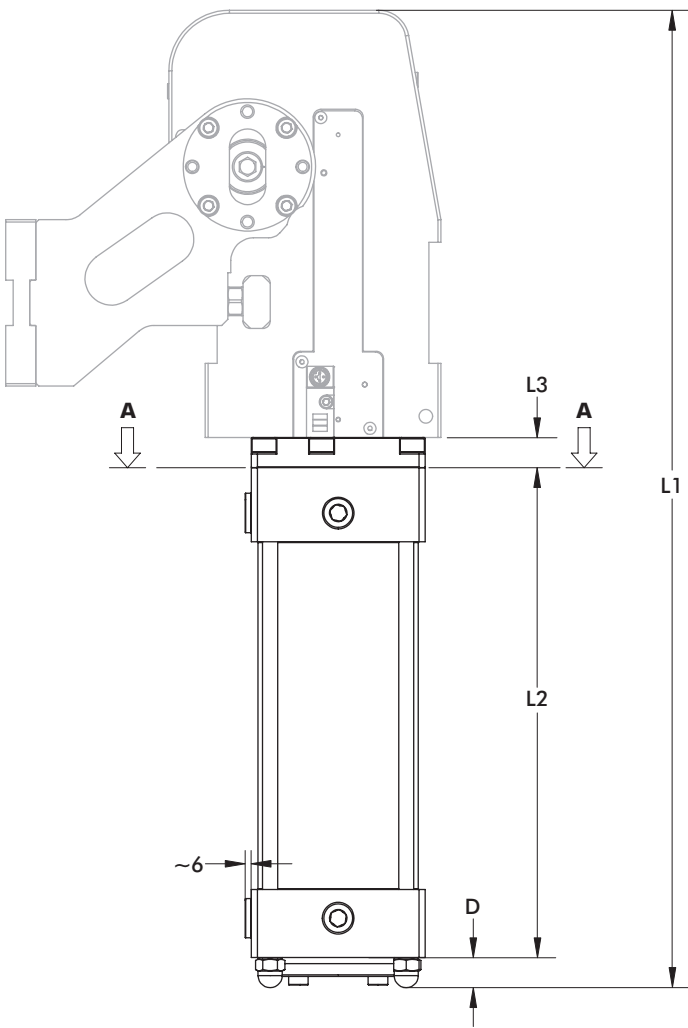

mm [INCH]  
THIRD ANGLE PROJECTION

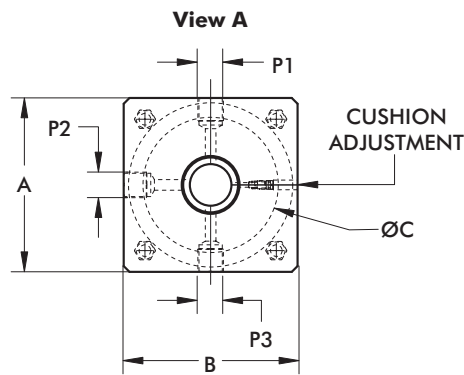

For Models	A	B	C	D	L1	L2	L3	P1-P3
RCM/RFM100.2	[4.53] 115	[4.53] 115	[3.94] 100	[0.75] 19	[25.41] 645,5	[12.76] 324	[0.79] 20	[1/2NPT] G1/2
RCM/RFM125.2	[6.30] 160	[6.30] 160	[4.92] 125	[0.91] 23	[29.17] 741	[14.35] 364,5	[0.94] 24	[3/4NPT] G3/4
RCM/RFM160.2	[7.09] 180	[7.09] 180	[6.30] 160	[0.75] 19	[29.55] 750,5	[14.59] 370,5	[1.08] 27,5	[3/4NPT] G3/4
RCM/RFM200.2	[8.66] 220	[8.66] 220	[7.87] 200	[0.75] 19	[29.70] 754,5	[14.82] 376,5	[1.16] 29,5	[3/4NPT] G3/4

### Loading Capacity

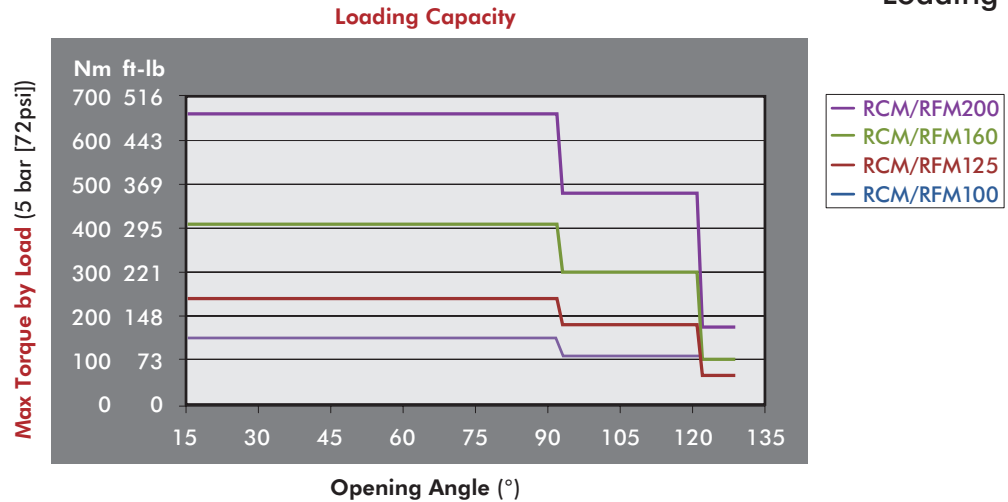

Model	Max. Torque by Load Nm [ft-lb]								
	Opening Angle ≤ 92°			Opening Angle > 92° / ≤ 121°			Opening Angle > 121°		
	4 bar [58 psi]	5 bar [72 psi]	6 bar [87 psi]	4 bar [58 psi]	5 bar [72 psi]	6 bar [87 psi]	4 bar [58 psi]	5 bar [72 psi]	6 bar [87 psi]
RCM/RFM100.2	120 [89]	150 [111]	190 [140]	90 [66]	110 [81]	130 [96]	45 [33]	55 [41]	65 [48]
RCM/RFM125.2	180 [133]	240 [177]	290 [214]	140 [103]	180 [133]	210 [155]	55 [41]	65 [48]	80 [59]
RCM/RFM160.2	320 [236]	410 [302]	500 [369]	260 [192]	300 [221]	360 [266]	85 [63]	100 [74]	125 [92]
RCM/RFM200.2	510 [376]	660 [487]	800 [590]	380 [280]	480 [354]	570 [420]	130 [96]	175 [129]	210 [155]

### Side Loading Capacity

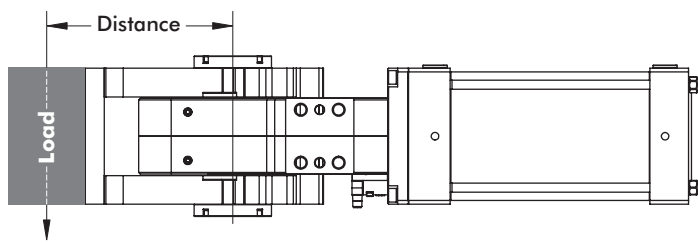

Max. applicable load with swivel unit positioned on its side (6 bar [87 psi])

Models	Max. Torque by Load @ 6 bar [87 psi] Nm [ft-lb]
RCM/RFM100.2	[59] 80
RCM/RFM125.2	
RCM/RFM160.2	[148] 200
RCM/RFM200.2	

### Angular Speed Limitation

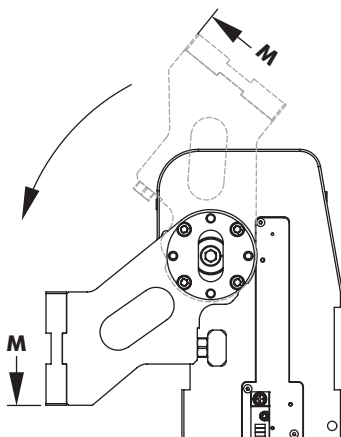

To avoid elevated angular speed it's necessary to respect the min. times among the electric signal of opening and that of closing brought in tab.

If don't respect the value report in tab, the device may break.

Model	Least Time Between Opening Electric Signal & Closing (Seconds) @ 6 bar [87 psi]				
	45°	76°	91°	121°	129°
RCM/RFM100.2	0.6	0.9	1.0	1.2	1.5
RCM/RFM125.2	0.8	1.1	1.2	1.4	1.7
RCM/RFM160.2	0.9	1.2	1.3	1.5	1.8
RCM/RFM200.2	1.4	1.7	1.8	2.1	2.5

# RCM/RFM

## Pneumatic Pivot Units | Time Diagrams

### Closing Operation

Working Pressure: 5 bar [72 psi]

Arm Type: O (shown)

Swivel Unit Position: Vertical (shown)

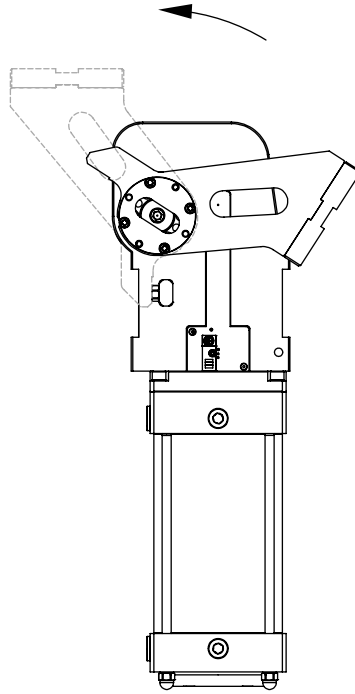

**RFM/RCM100.2**

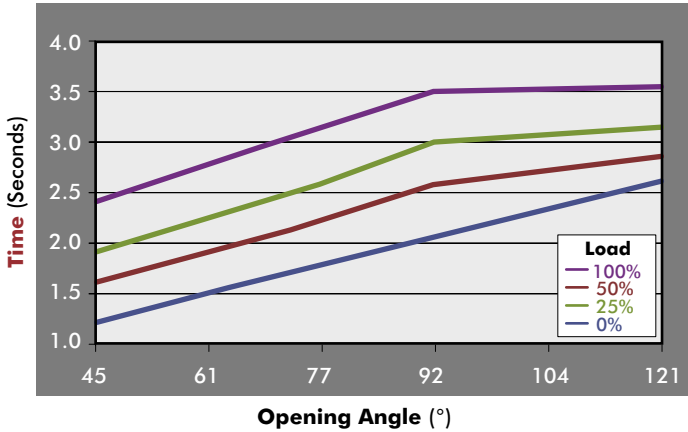

**RFM/RCM125.2**

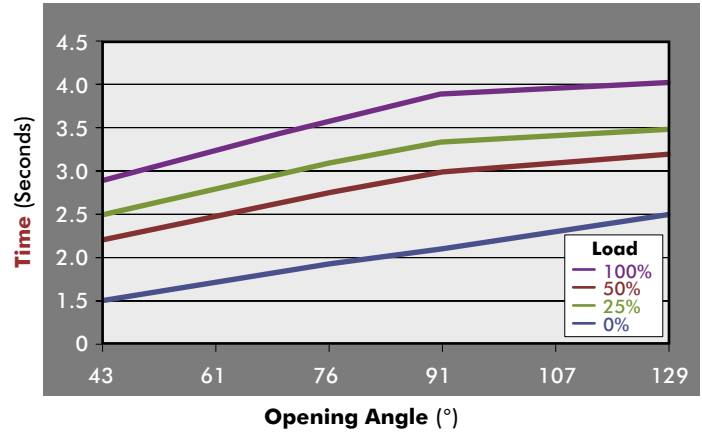

**RFM/RCM160.2**

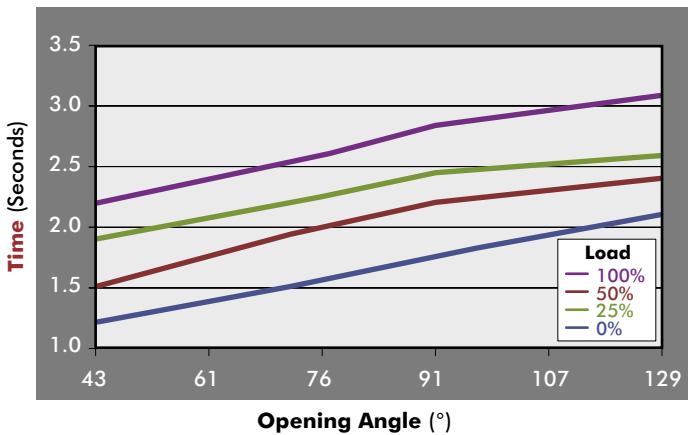

**RFM/RCM200.2**

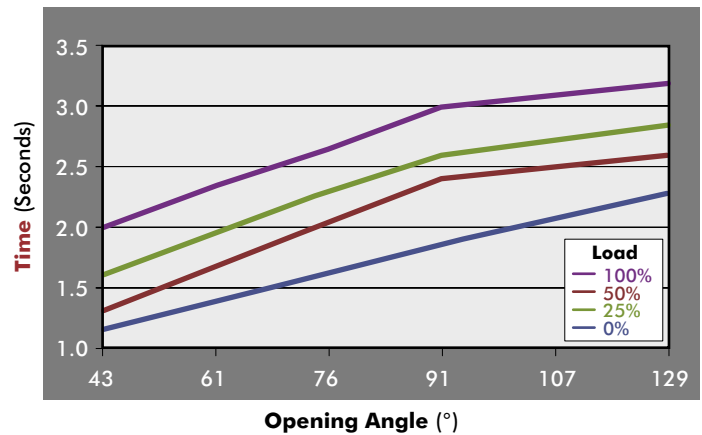

### Opening Operation

Working Pressure: 5 bar [72 psi]  
Arm Type: O (shown)  
Swivel Unit Position: Vertical (shown)

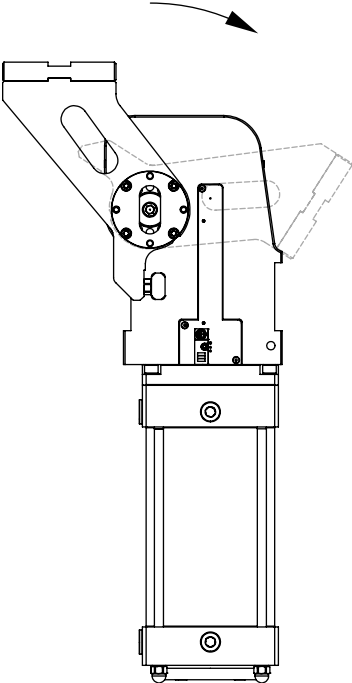

**RFM/RCM100.2**

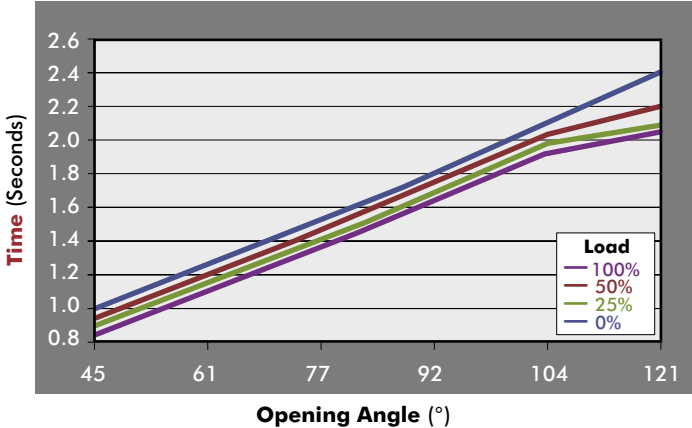

**RFM/RCM125.2**

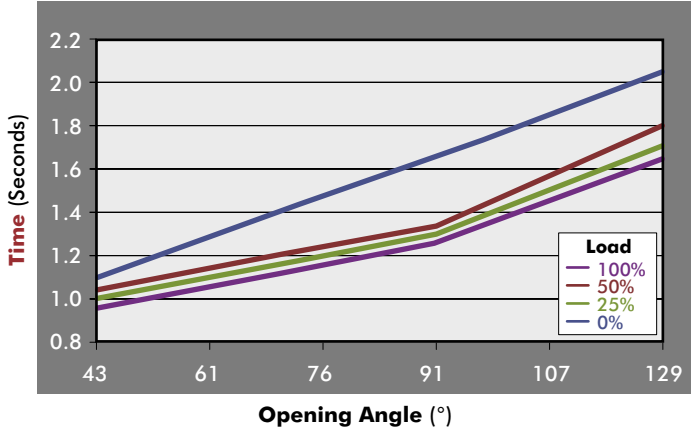

**RFM/RCM160.2**

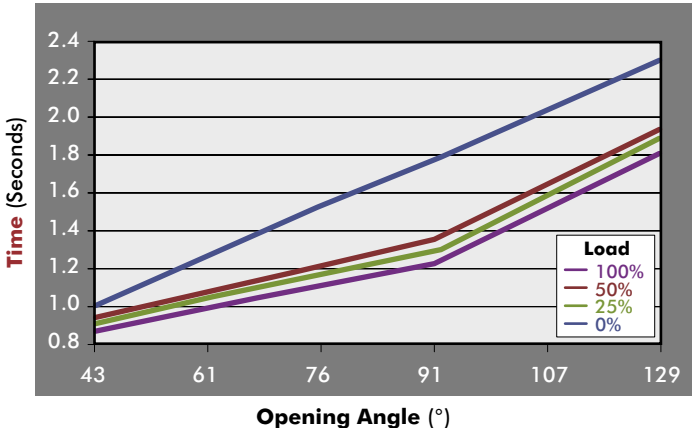

**RFM/RCM200.2**

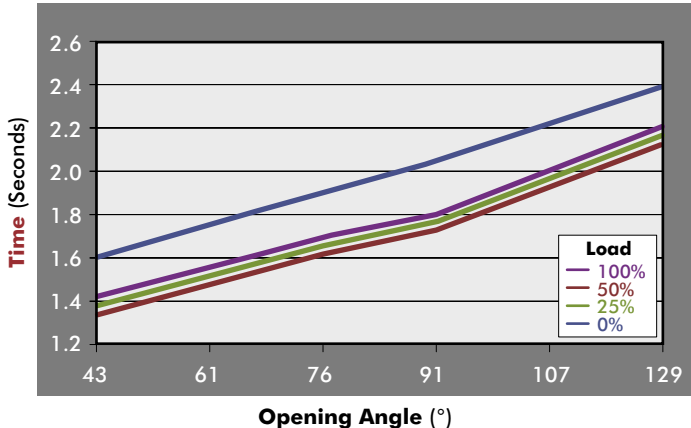

# RCM/RFM

## Pneumatic Pivot Units | Sensor Technical Specifications

### Open/Close Sensor

Proximity Switch Type:*	Pepperl+Fuchs
Feeding Voltage:	10-30 VDC
Max. Commutating Current:	200 mA
Power Supply:	< 20mA
Voltage Drop:	< 2 V
Temperature Range:	-25° / 70° C



Pepperl+Fuchs

### Pepperl+Fuchs

for Model	Power Amplifier (1)	Sensor's Satellite (2)	Complete Inductive Switch
RCM/RFM100.2	3/413	3/417	RFMSI – 1.2/A
RCM/RFM125.2			RFMSI – 125.2/A
RCM/RFM160.2			RFMSI – 160.2/A
RCM/RFM200.2			RFMSI – 200.2/A

- S01 = Opening Signal
- S02 = Closing signal
- Y = Yellow LED
- G = Green LED
- R = Red LED
- 1 = Brown Wire
- 2 = Black Wire
- 3 = Blue Wire
- 4 = White Wire

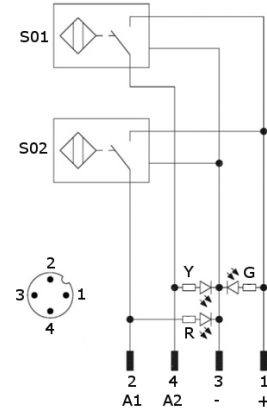

### Integrated Locking Sensor (SBI)

Locking Sensor Type:*	Pepperl+Fuchs
Output Type:	PNP
Feeding Voltage:	10-30 VDC
Max. Commutating Current:	200 mA
Power Supply:	< 25mA
Voltage Drop:	< 2 V
Temperature Range:	-25° / 70° C



Pepperl+Fuchs

### Pepperl+Fuchs

for Model	Sensor Type
RFM100.2	RF1 – BIF
RFM125.2	RF2 – BIF
RFM160.2	
RFM200.2	

- S01 = Opening Signal
- Y = Yellow LED
- G = Green LED
- 1 = Brown Wire
- 3 = Blue Wire
- 4 = White Wire

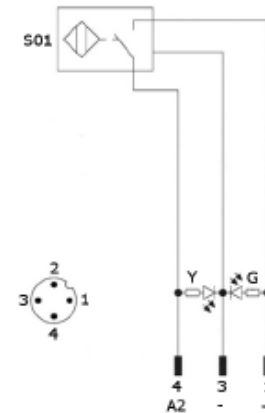

\*Proximity switch and locking sensor types cannot be mixed.

### Pneumatic Control Diagrams

**Control Valve: 5/3**  
**Pressure Range: 4-8 bar [58-116 psi]**

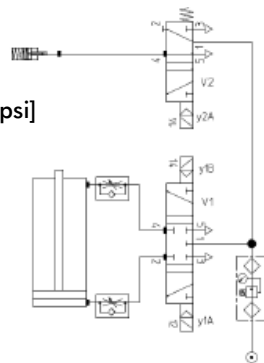

**Control Valve: 5/2**  
**Pressure Range: 4-8 bar [58-116 psi]**

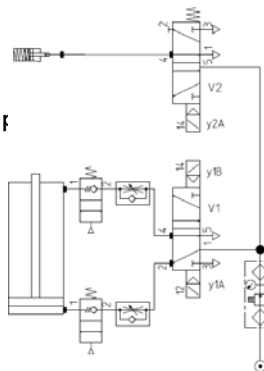

### Air Consumption

Model	Opening Angle (°)	Air consumption @ 5 bar [72 psi] litre [ft3]	Air Consumption @ 6 bar [87 psi] litre [ft3]
RCM/RFM100.2	29°	5,9 [167]	6,9 [195]
	77°	10,3 [292]	12,1 [343]
	121°	14,3 [405]	16,7 [473]
RCM/RFM125.2	15°	7,9 [224]	9,2 [261]
	76°	18,0 [510]	21,0 [595]
	107°	22,4 [634]	26,2 [742]
RCM/RFM160.2	129°	24,7 [699]	28,8 [816]
	15°	14,2 [402]	16,6 [470]
	76°	31,0 [878]	36,2 [1025]
RCM/RFM200.2	107°	38,5 [1090]	44,9 [1271]
	129°	42,2 [1195]	49,3 [1396]
	15°	20,8 [589]	24,3 [688]
RCM/RFM200.2	76°	47,4 [1342]	55,3 [1566]
	107°	59,2 [1676]	69,1 [1957]
	129°	65,1 [1843]	76,0 [2152]

### Shock Absorber, External Stop Guide Usage

Make sure that the swivel unit makes the complete stroke until the closing position is reached (0°). Any interference with external bodies can cause serious damage to the device and to the equipment mounted on it.

**Note:** The use of external stops and shock absorbers is not recommended as they can have negative effects on the life of the unit.

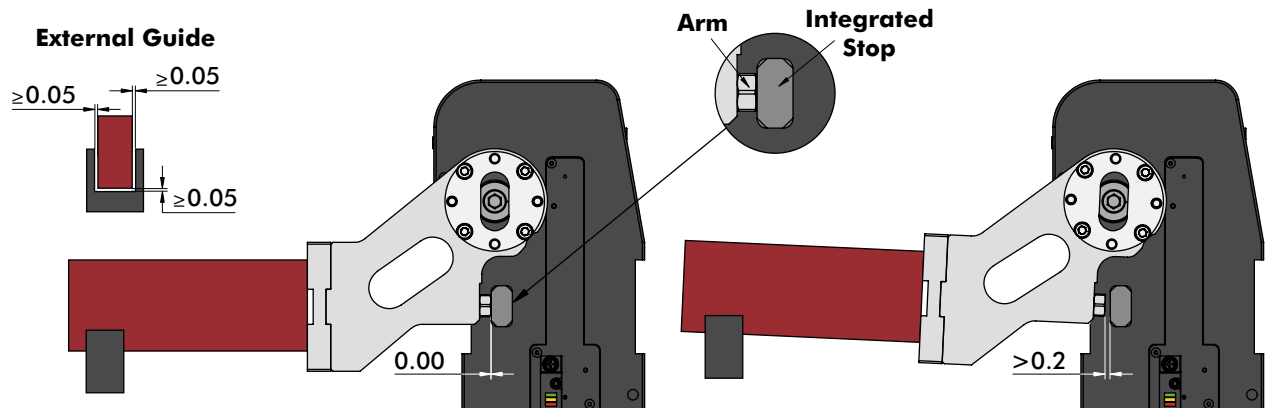

**CORRECT USE:** Integrated Stop is properly used. The distance between the arm and the Integrated Stop = [0.00] 0,00

**INCORRECT USE:** External Stop being used does not allow the arm to reach a 0° position. The distance between the arm and the Integrated Stop is greater than [0.008] 0,2

If External Guides are used, the following points must be guaranteed:

- The swivel unit must fully reach the closed position
- The above measures for External Guides must be maintained
- They must not be used as External Stops

If the points indicated above are not followed, we reserve the right to void the warranty.

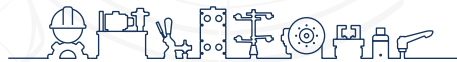

inf @ /CESEHSA.com.mx

