

PALLET CLAMP

01/28/2025



info@cesehsa.com.mx

cesehsa.com.mx

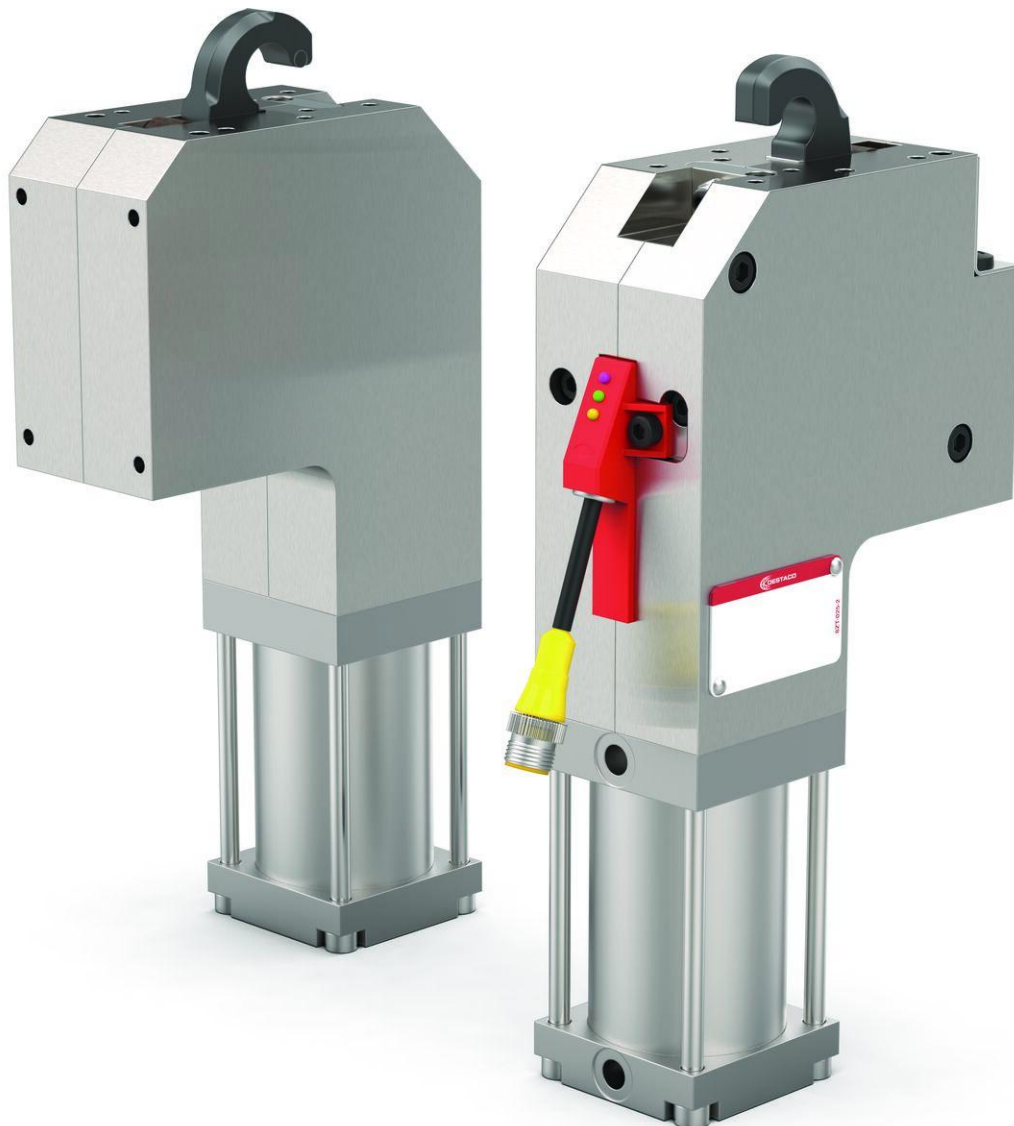

PALLET CLAMP

12/07/2020

This catalog is a custom document and the products included is based on your unique selection from portions of complete catalogs that already exist. Please refer to our full catalogs for more information on products not included in this customized document.

Table of Contents

Pallet Clamp

PC-HPC-23

Table of Contents (continued)

82U50-3

Pneumatic Pallet Clamp | Ordering and Technical Information

82U50 - **300** **L1** **00**

Size	Description
300	Front, top or bottom mounting
330	Top or bottom mounting only

Accessories	Description
00	No Accessories

Sensor	Description
L1	Without Sensing System
C8	Inductive Sensing System with M8x1 Connector (8EA-023-2)
B7	Inductive Sensing System, M12x1 Connector (8EA-060-1)
B8	Inductive Sensing System with M12x1 Cable Connector (8EA-031-1)



82U50-300

82U50-330



Specification	Unit	82U50
Max. Holding Force @ 5 bar	[lbf] N	[899] 4000
Max. Clamping Force @ 5 bar	[lbf] N	[899] 4000
Max. Operating Pressure	[psi] bar	[87] 6
Cylinder Diameter	mm	50
Weight	[lb] kg	[7.04] 3,2

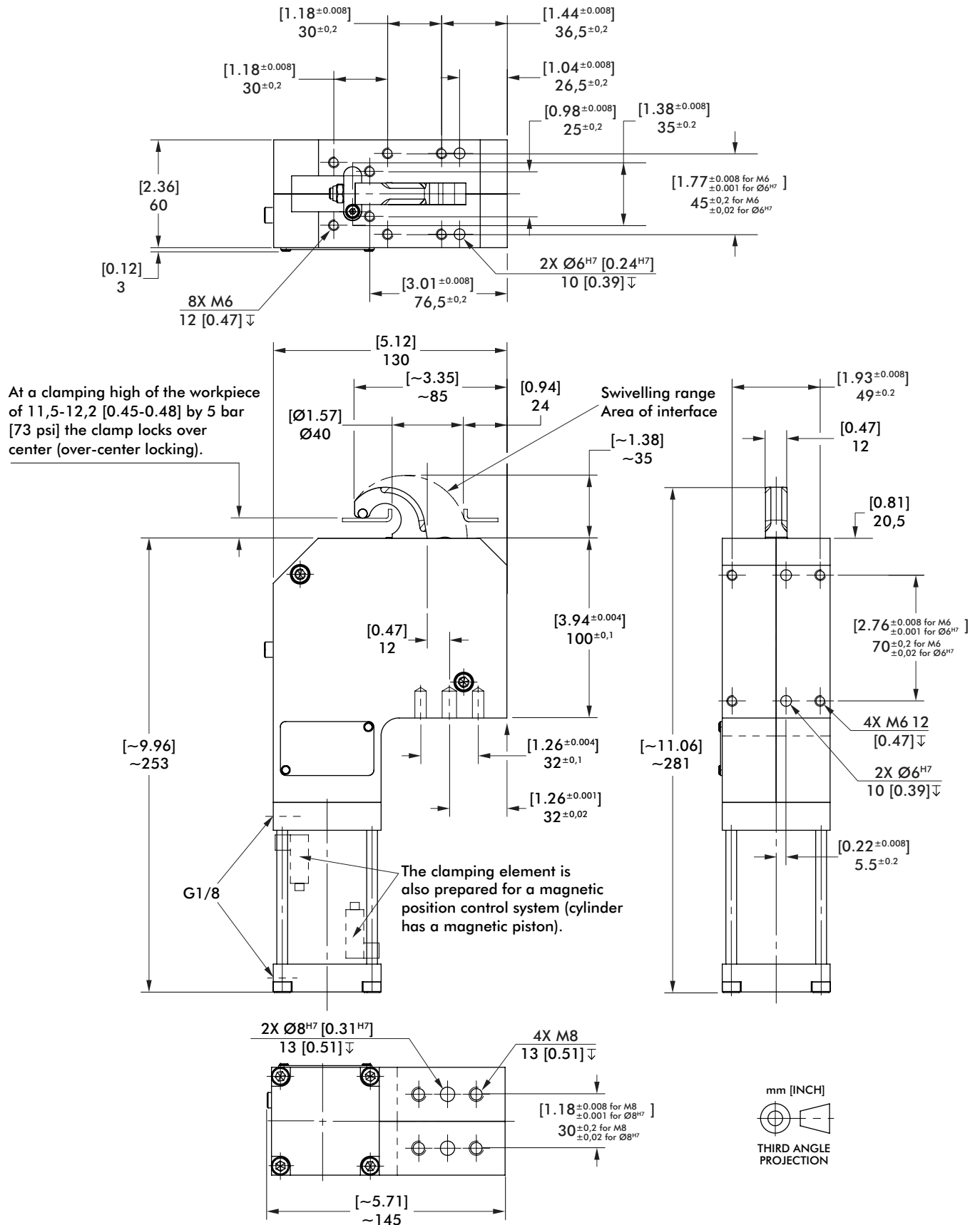

82U50-3

Pneumatic Pallet Clamp | Dimensions

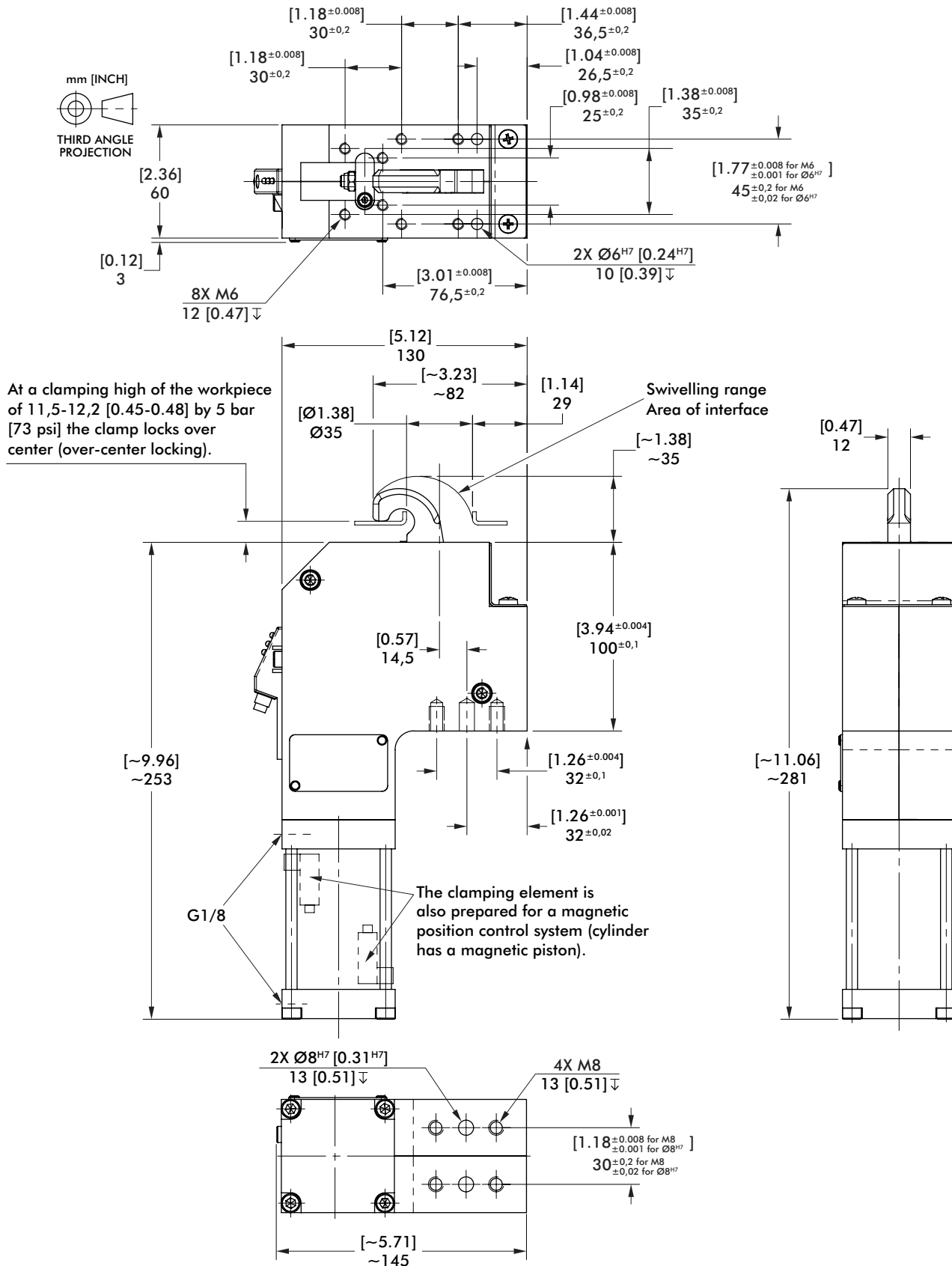

82U50-3 SENSORS

Pneumatic Pallet Clamp | Dimensions and Technical Specifications

Air Consumption

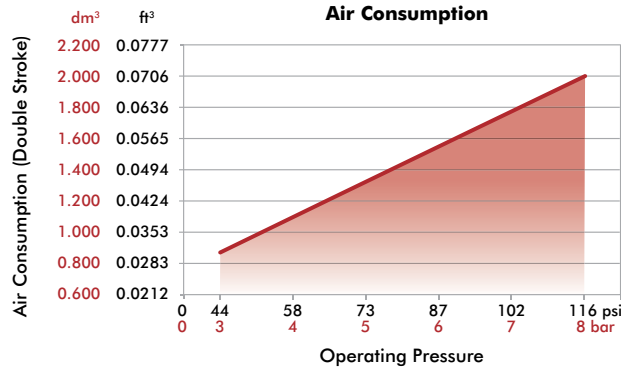

C8 M8 Inductive Sensing System

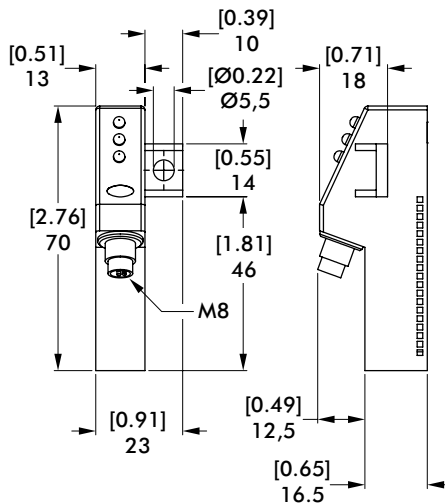

B7 M12 Inductive Sensing System

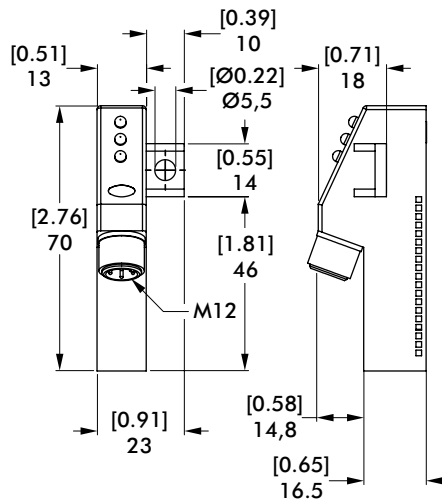

B8 M12 Inductive Sensing System with Pigtail Connector

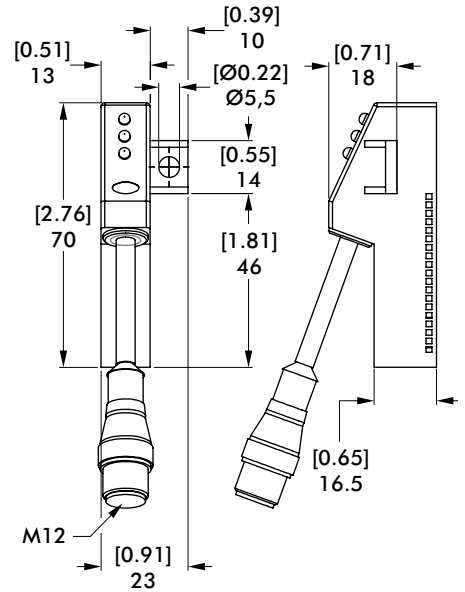

Sensor Cable Accessories and Spare Parts

Sensor Accessories	Order no.
B7/B8 Sensor Cables (1 connector & 5 m cable)	
M12x1 connector, straight, 5-pin	8EL-002-1
M12x1 connector, 90° angular, 4-pin	8EL-003-1
C8 Sensor Cables (1 connector & 5 m cable)	
M8x1 connector, straight, 5-pin	8EL-009-1
M8x1 connector, 90° angular, 4-pin	8EL-007-1
M8 to M12 Adaptor	8EL-008-1
Sensing system attached to cylinder	
Magnetic sensors plus installation material	8EA-025-1
Spare Parts	Order no.
Pneumatic Cylinder	8PW-007-1
Seal Kit	8PW-007-1-00
Spare Part Kit: Bushings, Bearings, pins	8KB-047-1

Inductive Sensor Wiring Diagram

Sensing system immune to interference from A.C./D.C. arc welding.

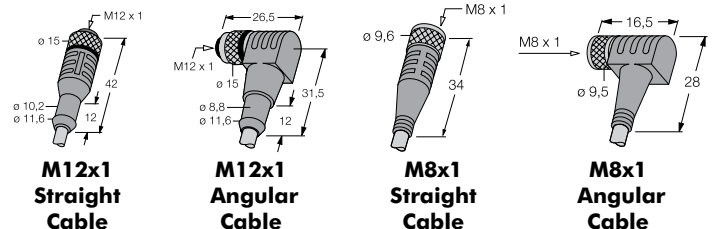
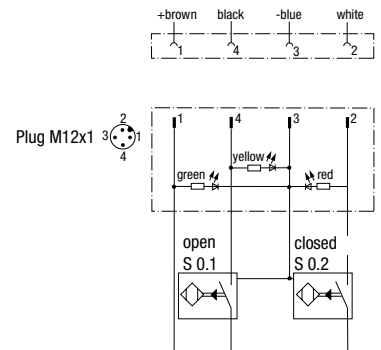

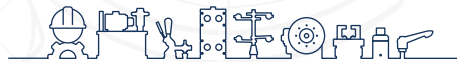

inf @ /CESEHSA.com.mx

