

Hydraulic Systems

01/28/2025



info@cesehsa.com.mx

cesehsa.com.mx



Hydraulic Systems

01/28/2025

This catalog is a custom document and the products included is based on your unique selection from portions of complete catalogs that already exist. Please refer to our full catalogs for more information on products not included in this customized document.

Table of Contents

Hydraulic Systems

MC-HYD-1



Hydraulic Systems





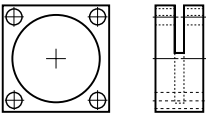

01/28/2025

Table of Contents (continued)

HYDRAULIC POWER CLAMPS

Table of Contents

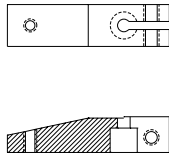
Hydraulic Clamping		Page MC-HYD-#
	010-210-400	3-4
	010-210-501	
	010-210-702	
	010-211-002	
	010-211-004	
	010-211-502	
	010-211-504	
	010-212-004	
	052-Series	4
	051-Series	4
	020-011-011DE	5
	020-012-021DE	
	020-013-031DE	

Hydraulic Clamping		Page MC-HYD-#
	030-1-S-475	7
	030-1-D-475	
	030-1-S-1100	8
	030-1-D-1100	
	030-1-S-2400	9
	030-1-D-2400	
	030-1-S-4000	10
	030-1-D-4000	10
	031-S-475	11-12
	031-L-475	
	031-S-1100	
	031-L-1100	
	031-S-2400	
	031-L-2400	
	031-S-4000	
	031-L-4000	
	039-101-000DE	13
	039-104-000DE	

BUILDING SAFE HYDRAULIC SYSTEMS

Hydraulic Power Clamps | Safety

Safety means paying attention to the smallest details. A hastily assembled workholding system can result in a hazardous operator environment. Hydraulic workholding is not a generic technique where most anything will work, nor is there one right or best answer for all situations. Each application is different and can be approached in many different ways. Because of this versatility, there is no rule-of-thumb to follow to guarantee safety. A careful balance of knowledge, fixture design and common sense are key to avoiding injuries.

Plan your fixture installation with operator safety in mind. By nature, most clamping devices have pinch points. Many times the fixture can be designed to shield the operator from a pinching hazard. Often the placement of the clamping device in the fixture can minimize the gap between the clamp and the workpiece, thus reducing or eliminating the pinch point. Perhaps the clamping control valve or switch can be located such that the operator cannot reach the fixture and the control at the same time. Dual palm buttons on electrically-actuated systems serve the same purpose.

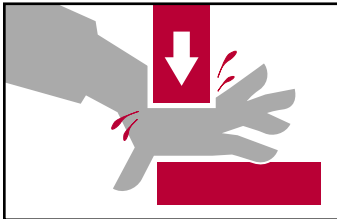

Do not require the operator to hold the workpiece in position during the clamping operation. Make sure that the workpiece is self-supporting and self-locating so that operator hands are out of

danger when the hydraulic system is actuated. Often a simple spring plunger is all that is necessary.

The lowest pressure rating of any component in the clamping system sets the *maximum* pressure rating for the entire system.

Most hydraulic workholding components are rated at 5,000 PSI maximum.

However, some components are rated at less than 5,000 PSI. The maximum pressure is listed on each product page of this catalog. *Never exceed this rating.*

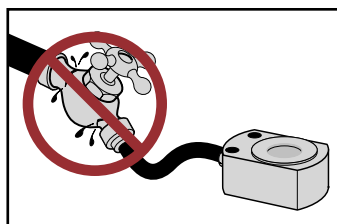

Just having a clamp that is rated at 5,000 PSI is not enough. Every hose, fitting, valve, adapter and tube exposed to pressure must be rated at or above the maximum hydraulic system pressure. Most

“hardware store” fittings are intended only for low pressure plumbing. *Never use water pipe fittings or copper tubing and brass fittings for hydraulic service.*

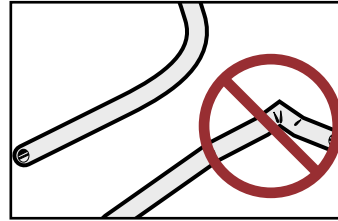

Use proper tools when bending tubing, and maintain proper minimum bend radii for hoses and tubing. If a hose or tube is ever kinked, replace it. Don't risk a rupture. Fluid escaping

under high pressure is dangerous. The resulting loss in pressure could release the workpiece from the fixture and cause serious injury and equipment damage by being ejected from the machine or breaking tooling.

Tubing and hoses do flex when pressurized. Allow for that movement by supporting the fluid lines away from surfaces which could abrade the surface and eventually cause damage. Avoid straight lengths of hose and tubing. A bend will allow for this deflection without putting too much stress on the line.

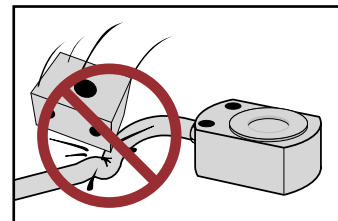
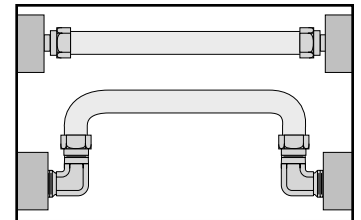

Even if proper hydraulic tubing and fittings are specified, be sure to protect them from abuse. Components damaged from abrasion or accidental dropping of a workpiece will no longer

have the strength and safety of the original design.

Use **proper mounting hardware** when installing workholding clamps and other components. Always use the largest bolt available to fit in the mounting hole. In many cases, the recommended cap screw or thread is specified on the product page of this catalog. Sometimes the mounting hardware is included with the component. Always use supplied hardware.

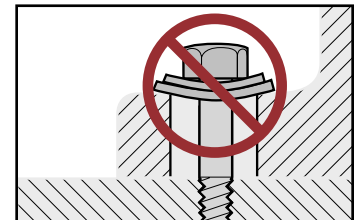

**Safety means
paying attention to
the smallest details.**

010 SERIES

Hydraulic Power Clamps | Hydraulic Threaded Body Cylinders Product Overview

The single-action, spring-return hydraulic power cylinders are small pistons that can be used singly or combined. They offer tremendous force in a small, easily mounted package that can be used in any attitude and requires only a single inlet port. They are often used grouped together by a common manifold to provide as much force as needed for the operation. For a relatively small volume of oil, they provide exceptional exerting force, and are generally the best choice if stroke lengths can be kept short.

Features:

- Threaded body for easy mounting
- Small size permits "low profile" workholding
- Accessories available for easy mounting
- Available in metric or inch sizes (Metric on special request)
- Hardened piston and rod
- Single-acting for simple plumbing
- Wide variety of sizes and strokes
- Pressure capacity up to 5,000 PSIG, provided piston does not bottom out



Technical Information

Model no.	SAE Ports	Threaded Body	Stroke	Force at 3,000 PSIG	Oil Displacement	Effective Area For Clamping	Jam Nuts
010-210-400	#2	1/2-20	0.22	277 lbs.	0.020 cu. in.	0.092	Furnished
010-210-501	#4	3/4-16	0.31	588 lbs.	0.061 cu. in.	0.196	Furnished
010-210-702	#4	1-12	0.50	1,326 lbs.	0.221 cu. in.	0.442	Furnished
010-211-002	#4	1 5/16-16	0.50	2,355 lbs.	0.393 cu. in.	0.785	Optional
010-211-004	#4	1 5/16-16	1.00	2,355 lbs.	0.785 cu. in.	0.785	Optional
010-211-502	#4	1 7/8-16	0.50	5,301 lbs.	0.884 cu. in.	1.767	Optional
010-211-504	#4	1 7/8-16	1.00	5,301 lbs.	1.767 cu. in.	1.767	Optional
010-212-004	#4	2 1/2-16	1.00	9,423 lbs.	3.142 cu. in.	3.142	Optional

Hydraulic Power Clamps | Hydraulic Threaded Body Cylinders Product Overview

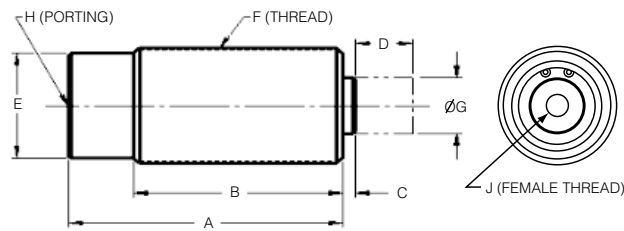

Model no.	Dimensions (In Inches)								
	A	B	C	D	E	F	G	H	J
010-210-400	1.66	1.41	0.19	0.22	.044 Hex	1/2-20	0.15	SAE #2	-
010-210-501	2.25	1.97	0.22	0.31	.062 Hex	3/4-16	0.22	SAE #4	-
010-210-702	2.56	2.31	0.31	0.50	.075 Hex	1-12	.024	SAE #4	-
010-211-002	2.63	2.25	0.13	0.50	1.00 Hex	1 5/16-16	0.64	SAE #4	1/4-20
010-211-004	3.63	3.25	0.12	1.00	1.00 Hex	1 5/16-16	0.64	SAE #4	1/4-20
010-211-502	2.94	2.57	0.13	0.50	1.50 Hex	1 7/8-16	1.00	SAE #4	5/16-18
010-211-504	4.59	4.22	0.14	1.00	1.50 Hex	1 7/8-16	1.00	SAE #4	5/16-18
010-212-004	4.13	3.76	0.13	1.00	2.00 Hex	2 1/2-16	1.50	SAE #4	5/16-18

Series 052 Flange Mount

Model no.	Dimensions (In Inches)				
	A	B	C	øD	E
052-112-160	1 1/8-16 UN 2B	1.50	0.50	0.22	1.030
052-131-160	1 5/16-16 UN 2B	1.69	0.50	0.27	1.250
052-137-180	1 3/8-16 UN 2B	1.75	0.50	0.27	1.340
052-187-160	1 7/8-16 UN 2B	2.25	1.00	0.34	1.770
052-250-160	2 1/2-16 UN 2B	3.00	1.00	0.34	2.170

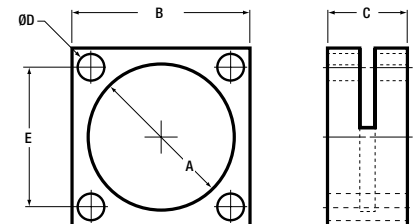

Series 051 Jam Nut

Model no.	Dimensions (In Inches)				
	A	B	C	D	E
051-112-160	1 1/8-16 UN 2B	1.500	0.31	0.250	0.250
051-131-160	1 5/16-16 UN 2B	1.688	0.31	0.250	0.250
051-137-180	1 3/8-16 UN 2B	1.875	0.31	0.250	0.250
051-187-160	1 7/8-16 UN 2B	2.625	0.38	0.312	0.132
051-250-160	2 1/2-16 UN 2B	3.250	0.50	0.312	0.312

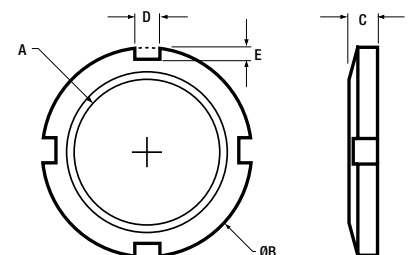

020 SERIES

Hydraulic Power Clamps | Thru-Hole Hydraulic Ram Product Overview

By inserting a rod through the hollow piston, these cylinders can be used to push or pull depending on the orientation of the ram. They will actuate a rod of any length or shape and are extremely effective in translating power to a remote location. Greater forces are generated in these thru-hole rams because of their larger piston area.

Features:

- Larger piston diameter for greater clamping forces
- Hardened steel piston and rod
- Single-acting for simple plumbing
- Optional threaded inserts
- Optional mounting plate (permits mounting ram with a single cap screw)



Symbol

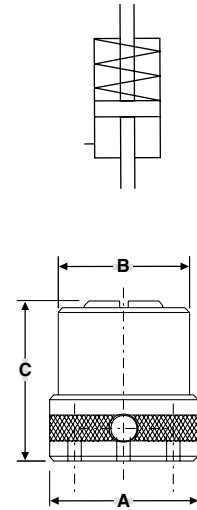

Model no.	RAM I.D.*	Port	Stroke	Force at 3,000 PSIG	Oil Displacement	Dimensions		
						A	B	C
020-011-011DE	0.38	SAE #2	0.38	4,380 lbs.	0.547 cu. in.	2.13	1.88	2.25
020-012-021DE	0.50	SAE #4	0.50	8,100 lbs.	1.35 cu. in.	3.00	2.63	2.88
020-013-031DE	0.63	SAE #4	0.63	12,066 lbs.	2.51 cu. in.	3.25	3.00	3.63

* Clearance for rod or bolt of given dimension.

Maximum input pressure 3,500 PSIG.

Accessories

All size thru-hole rams are supplied with a thru-hole insert threaded into the top.

RAM no.	Thru-Hole Insert (supplied)
020-011-011DE	705384
020-012-021DE	705512
020-013-031DE	705634

Loads Transmitted by Various Diameter Screws		
Bolt Size	Wrench Length	F-lbs. (Average)
1/4 UNF	4.00	2,400 lbs.
1/4 UNF	4.00	1,920 lbs.
3/8 UNF	5.75	3,000 lbs.
3/8 UNF	5.75	2,920 lbs.
1/2 UNF	8.00	4,200 lbs.
1/2 UNF	8.00	3,640 lbs.
5/8 UNF	9.00	5,600 lbs.
5/8 UNF	9.00	5,600 lbs.
3/4 UNF	9.00	4,800 lbs.
3/4 UNF	11.00	4,200 lbs.
7/8 UNF	12.00	50,400 lbs.

To determine how much force is needed to replace a manual clamp, use this chart as a guide.

A thru-hole ram easily converts a manual strap clamp into an automatic hydraulic powered clamp. Usually a longer bolt is the only part needed to make this conversion.

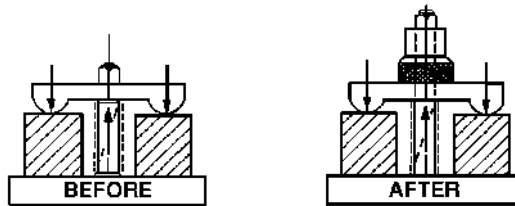

Calculation of Forces Using Straps and Levers

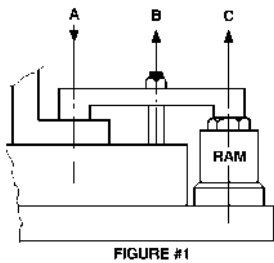

Figure #1
When the distance AB is equal to the distance BC the force upward from Model 020-011-011DE Ram "C" is equal to the downward force "A" on the part.

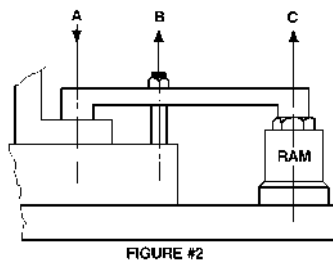

Figure #2
The downward force "A" is equal to the upward force "C" times a ratio of the distance BC:AB.
Example:
AB = 2", BC = 4", Force "C" = 1,000 lbs.
Force "A" = Force "C" x $\frac{BC}{AB}$
"A" = 1,000 lbs. x $\frac{4}{2}$
"A" = 2,000 lbs.

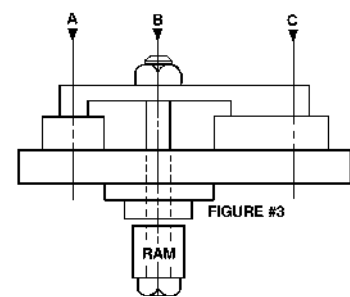
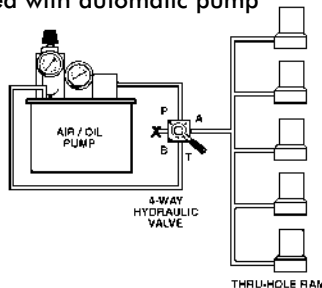

Figure #3
When Force "B" from Model 020-011-011DE Hollow Bore is divided between "A" & "C", the forces at "A" & "C" are in inverse ratio to the distance AB & BC respectively.
Force "A" = Force "B" x $\frac{BC}{AB}$
Force "C" = Force "B" x $\frac{AB}{AC}$
Example:
AB = 2", BC = 4", Force "B" = 1,000 lbs.
Force "A" = 1,000 lbs. x $\frac{4}{6}$ = 666.7 lbs.
Force "C" = 1,000 lbs. x $\frac{2}{6}$ = 333.3 lbs.

Power Sources

Thru-hole Rams can be powered by automatic pumps, hand pumps, boosters or existing machine hydraulics.

Used with automatic pump



Used with hand pump

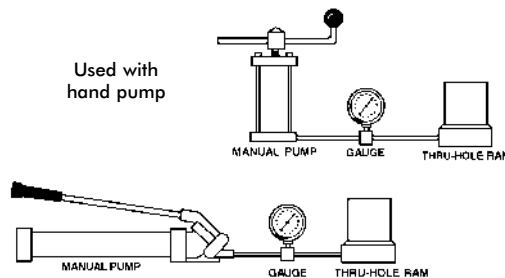

Used with booster

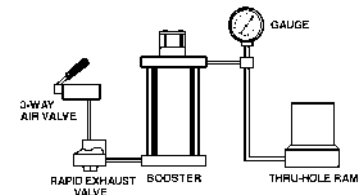

Multiple Uses

Thru-hole Rams can be used to push or pull depending on the position of the ram.

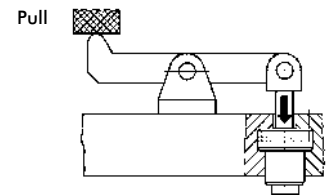
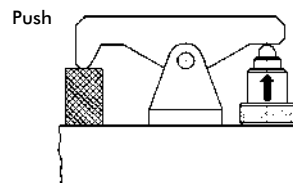
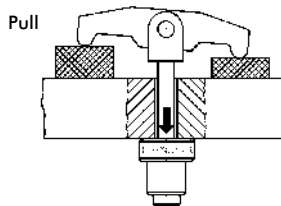
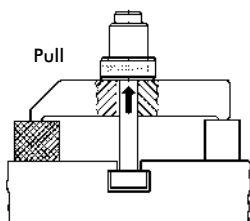

030 SERIES

Hydraulic Power Clamps | Hydraulic Swing Clamps – 475 lb.

The DESTACO Threaded Body Swing Clamps are available in both single-acting and double-acting versions. They incorporate the latest hydraulic swing clamp technology. The top port design allows easy access for plumbing connections.

They are available with 90° left or right hand rotation. The breather port on single-acting models may be replaced with tubing for remote venting. The optional arms clamp securely to the piston rod to reduce fatigue and deflection. Arms may be easily modified or custom arms may be substituted.

Features:

- Advanced seals and wipers utilize a special, highly wear-resistant construction for long cycle life and 5,000 PSI operation
- Triple track piston rod design for field adjustable swing direction
- Hardened and hard chrome plated piston rod for increased strength and wear resistance
- Advanced metal treated body for superior wear and corrosion resistance
- MRO interchange design

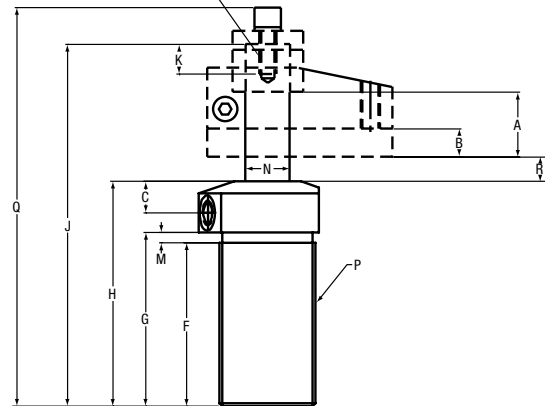
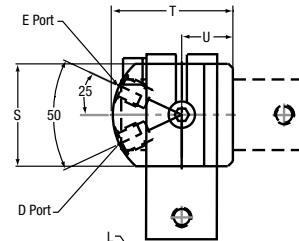
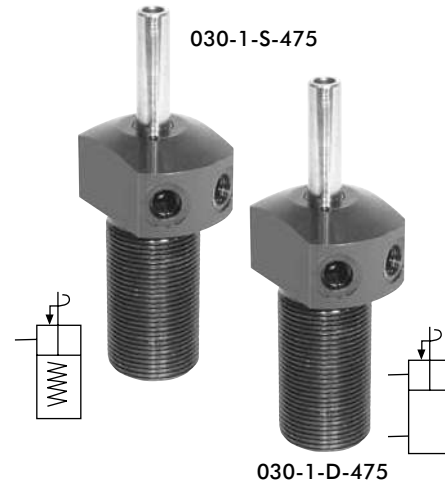

For 475 lb. Swing Clamp Arms see Page MC-HYD-11

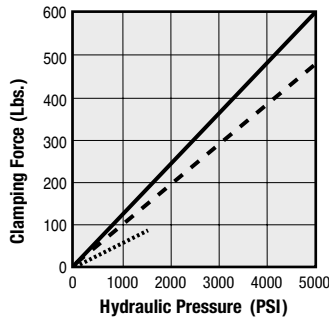

Performance

- With 031-L-475 Arm (3.25" long)
- - - With 0-31-S-475 Arm (1.22" long)
- Straight Pull

Cat. no.	Specifications							Max Oil Flow in ³ /m in
	Oper.	Swing Direction	*Force (lbs.)	Eff. Area (sq. In.) Clamp Unclamp	Oil Cap. (cu. In.) Clamp Unclamp			
030-1-S-475 (-X) †	Single-Acting	Left Hand (Counter Clockwise)	475	0.12	—	0.08	—	12
030-1-D-475 (-X) †	Double-acting	Right Hand (Clockwise)	475	0.12	0.24	0.08	0.15	12

Ordering Notes:
 • Left hand swing (ccw) is standard—no suffix
 • Add -R suffix for right hand swing

Cat. no.	Specifications																			
	A Total Stroke	B Clamping Stroke	C	D Clamp Port	E Unclamp Port	F	G	H	J	K	L	M	N	P	Q	R	S	T	U	
030-1-S-475 †	0.65	0.210	0.59	SAE-2	SAE-2	1.929	2.086	3.07	4.429	0.8	M6x1	0.157	0.393	1-1/8-16UN	4.96	0.495	1.3	1.55	0.61	
030-1-D-475 †	0.65	0.32	0.59	SAE-2	SAE-2	1.929	2.086	3.07	4.429	0.8	M6x1	0.157	0.393	1-1/8-16UN	4.96	0.495	1.3	1.55	0.61	

† This item is available upon request

NOTE: *With 1.22" long arm at 5,000 PSI maximum operating pressure.
 ‡ Do not pressurize – single-acting only
 † See page MC-HYD-11 for arms, accessories and custom arm mounting

Hydraulic Power Clamps | Hydraulic Swing Clamps – 1,100lb.

The DESTACO Threaded Body Swing Clamps are available in both single-acting and double-acting versions. They incorporate the latest hydraulic swing clamp technology. The top port design allows easy access for plumbing connections.

They are available with 90° left or right hand rotation. The breather port on single-acting models may be replaced with tubing for remote venting. The optional arms clamp securely to the piston rod to reduce fatigue and deflection. Arms may be easily modified or custom arms may be substituted.

Features:

- Advanced seals and wipers utilize a special, highly wear-resistant construction for long cycle life and 5,000 PSI operation
- Triple track piston rod design for field adjustable swing direction
- Hardened and hard chrome plated piston rod for increased strength and wear resistance
- Advanced metal treated body for superior wear and corrosion resistance
- MRO interchange design

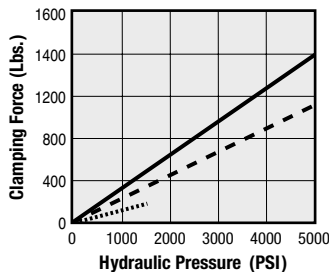

Performance

- With 031-L-1100 Arm (5.31" long)
- - - With 031-S-1100 Arm (1.89" long)
- Straight Pull

For 1,100 lb.
Swing Clamp Arms
see Page MC-HYD-12

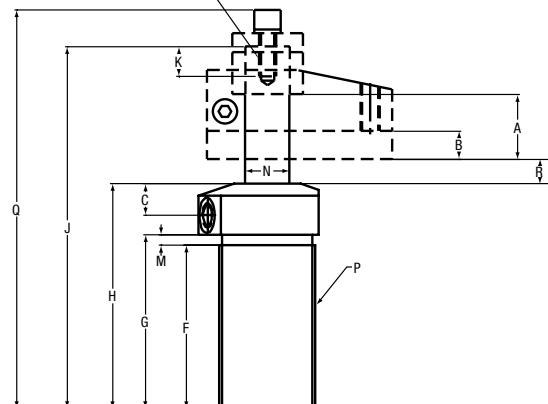
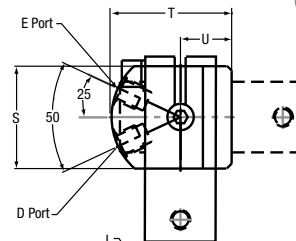
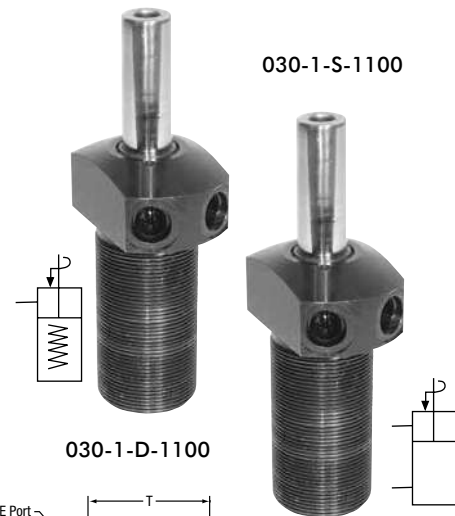

Ordering Notes:

- Left hand swing (ccw) is standard – no suffix
- Add -R suffix for right hand swing

Cat. no.	Specifications							Max Oil Flow in ³ /m in
	Oper.	Swing Direction	*Force (lbs.)	Eff. Area (sq. In.) Clamp Unclamp	Oil Cap. (cu. In.) Clamp Unclamp			
030-1-S-1000 (-X) ⓘ	Single-Acting	Left Hand (Counter Clockwise)	1100	0.28	-	0.25	-	25
030-1-D-1000 (-X) ⓘ	Double-acting	Right Hand (Clockwise)			0.59	0.52		

Cat. no.	Specifications																		
	A Total Stroke	B Clamping Stroke	C	D Clamp Port	E Unclamp Port	F	G	H	J	K	L	M	N	P	Q	R	S	T	U
030-1-S-1100 ⓘ	0.89	0.39	0.6	SAE-4	SAE-4	2.4	2.6	3.58	5.305	0.94	M8 x 1.25	0.196	0.629	1-3/8-18UN	5.965	0.400	1.5	1.87	0.75
030-1-D-1100 ⓘ																			

ⓘ This item is available upon request

NOTE: *With 1.89" long arm at 5,000 PSI maximum operating pressure.
 †Do not pressurize – single-acting only
 ‡ See page MC-HYD-12 for arms, accessories and custom arm mounting

030 SERIES

Hydraulic Power Clamps | Hydraulic Swing Clamps – 2,400 lb.

The DESTACO Threaded Body Swing Clamps are available in both single-acting and double-acting versions. They incorporate the latest hydraulic swing clamp technology. The top port design allows easy access for plumbing connections.

They are available with 90° left or right hand rotation. The breather port on single-acting models may be replaced with tubing for remote venting. The optional arms clamp securely to the piston rod to reduce fatigue and deflection. Arms may be easily modified or custom arms may be substituted.

Features:

- Advanced seals and wipers utilize a special, highly wear-resistant construction for long cycle life and 5,000 PSI operation
- Triple track piston rod design for field adjustable swing direction
- Hardened and hard chrome plated piston rod for increased strength and wear resistance
- Advanced metal treated body for superior wear and corrosion resistance
- MRO interchange design

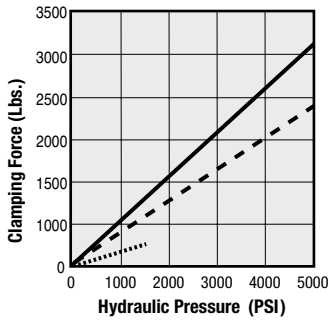
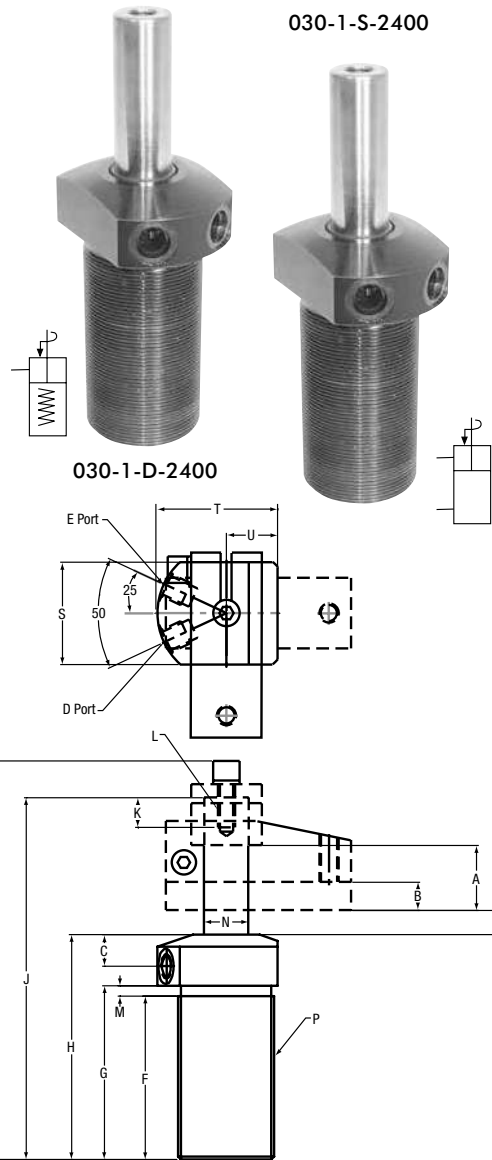

For 2,400 lb.
Swing Clamp Arms
see Page MC-HYD-11

Performance

- With 031-L-2400 Arm (6.36" long)
- - - - With 031-S-2400 Arm (2.43" long)
- ——— Straight Pull

Cat. no.	Specifications								Max Oil Flow in ³ /m in
	Oper.	Swing Direction	*Force (lbs.)	Eff. Area (sq. In.)	Oil Cap. (cu. In.)	Clamp	Unclamp	Clamp	
030-1-S-2400 (-X) ⓘ	Single-Acting	Left Hand (Counter Clockwise) Right Hand (Clockwise)	2400	0.63	0.7	-	-	1.10	100
030-1-D-2400 (-X) ⓘ	Double-acting					1.23	-		

- Ordering Notes:**
- Left hand swing (ccw) is standard—no suffix
 - Add -R suffix for right hand swing

Cat. no.	Specifications																		
	A Total Stroke	B Clamping Stroke	C	D Clamp Port	E Unclamp Port	F	G	H	J	K	L	M	N	P	Q	R	S	T	U
030-1-S-2400 ⓘ	1.12	0.5	0.62	SAE-4	SAE-4	†	3.38	4.38	6.8	1.28	M10x1.5	0.196	0.87	1-7/8-16UN	7.543	0.517	2.0	2.38	1.0
030-1-D-2400 ⓘ																			

ⓘ This item is available upon request

NOTE: *With 2.43" long arm at 5,000 PSI maximum operating pressure.

‡Do not pressurize – single-acting only

† See page MC-HYD-11 for arms, accessories and custom arm mounting

Hydraulic Power Clamps | Hydraulic Swing Clamps – 4,000 lb.

The DESTACO Threaded Body Swing Clamps are available in both single-acting and double-acting versions. They incorporate the latest hydraulic swing clamp technology. The top port design allows easy access for plumbing connections.

They are available with 90° left or right hand rotation. The breather port on single-acting models may be replaced with tubing for remote venting. The optional arms clamp securely to the piston rod to reduce fatigue and deflection. Arms may be easily modified or custom arms may be substituted.

Features:

- Advanced seals and wipers utilize a special, highly wear-resistant construction for long cycle life and 5,000 PSI operation
- Triple track piston rod design for field adjustable swing direction
- Hardened and hard chrome plated piston rod for increased strength and wear resistance
- Advanced metal treated body for superior wear and corrosion resistance
- MRO interchange design

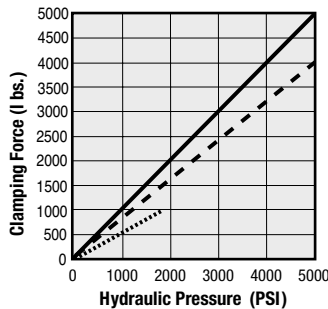
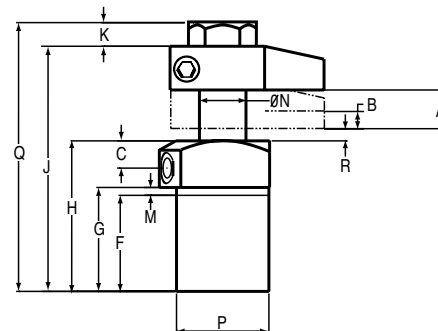
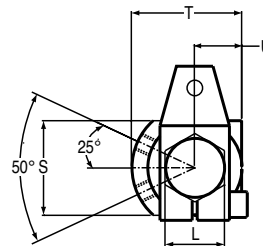

Performance

- With 031-L-4000 Arm (X.XX" long)
- - - With 031-S-4000 Arm (X.XX" long)
- Straight Pull

For 4,000 lb.
Swing Clamp Arms
see Page MC-HYD-11

Cat. no.	Specifications							Max Oil Flow in ³ /m in
	Oper.	Swing Direction	*Force (lbs.)	Eff. Area (sq. In.) Clamp Unclamp	Oil Cap. (cu. In.) Clamp Unclamp			
030-1-S-4000 (-X) ⓘ	Single-Acting	Left Hand (Counter Clockwise)	4000	1.10	-	1.22	-	140
030-1-D-4000 (-X) ⓘ	Double-acting	Right Hand (Clockwise)		2.35	2.60			

- Ordering Notes:
- Left hand swing (ccw) is standard—no suffix
 - Add -R suffix for right hand swing

ⓘ This item is available upon request

Cat. no.	Specifications																		
	A Total Stroke	B Clamping Stroke	C	D Clamp Port	E Unclamp Port	F	G	H	J	K	L	M	N	P	Q	R	S	T	U
030-1-S-4000 ⓘ	1.07	0.45	0.75	SAE#4	SAE#4	2.70	2.83	4.09	6.67	0.64	1.61	0.14	1.26	2-1/2-16 UN	7.30	0.33	2.56	2.99	1.28
030-1-D-4000 ⓘ																			

ⓘ This item is available upon request

NOTE: *With 2.75" long arm at 5,000 PSI maximum operating pressure.
[‡]Do not pressurize – single-acting only
[†] See page MC-HYD-11 for arms, accessories and custom arm mounting

030 SERIES

Hydraulic Power Clamps | Hydraulic Swing Clamps 475-2,400 lb. Arms

Custom built arms of any length must clamp to the swing clamp's piston rod in a manner similar to the DESTACO arms or some derating of the clamp will be necessary.

The design feature "K," in the chart and drawing at the bottom of this page, is recommended for all applications of custom, single arms. See the accompanying chart for design details. In applications where there is no bending stress being transferred into the piston rod (like push/pull linkages and equalizing double arms), this design detail may be eliminated. In these applications, the clamp's full capacity (referred to as "straight pull" capacity) is available.

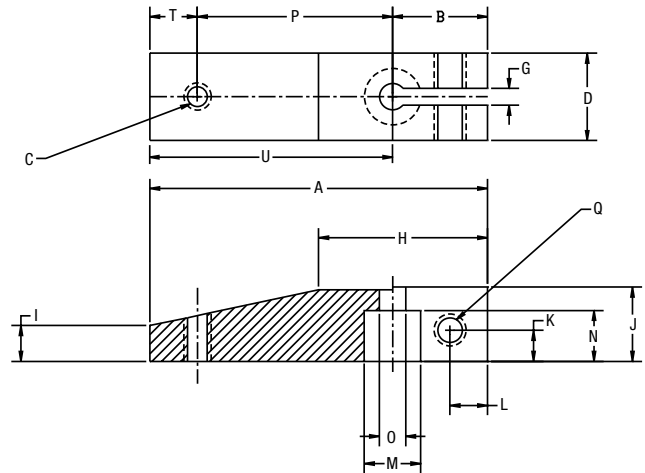

Cat. no.	Specifications																	Weight (lbs.)
	A	B	C	D	G	H	I	J	K	L	M	N	O	P	Q	T	U	
031-S-475	1.929	0.709	M6	0.63	0.126	1.139	0.394	0.630	0.236	0.217	0.394	0.394	0.256	0.984	M6	0.236	1.220	0.159
031-L-475	3.959	0.709	-	0.63		1.166	0.394	0.630			0.394	0.394	0.256	-	M6	-	3.250	0.348
031-S-1100	2.598	0.709	M8	0.748		1.294	0.433	0.748			0.630	0.472	0.33	1.575	M6	0.315	1.889	0.286
031-L-1100	6.019	0.709	-	0.748		1.412	0.433	0.748			0.630	0.472	0.335	-	M6	-	5.310	0.721
031-S-2400	3.268	0.866	M10	1.125		1.459	0.633	1.00			0.866	0.709	0.413	1.969	M8	0.433	2.402	0.634
031-L-2400	7.226	0.866	-	1.125		1.696	0.633	1.00			0.866	0.709	0.413	-	M8	-	6.360	1.564

IMPORTANT: Any clamp using a modified or custom arm that is longer or heavier than DESTACO's standard arms must be derated to prevent internal damage.
Do not exceed the maximum speed and pressure ratings for DESTACO's standard arms.
For maximum hydraulic pressure and speed ratings, see the accompanying charts
Do not use meter-out circuitry for controlling double-acting clamp speeds
Contact DESTACO if further design assistance is required

Custom Arm Mounting Dimensions for Swing Clamps

Shaft Dia.	Specifications										
	A	B	C	D	E	F	G	H	J	K	M
10 MM	0.394	0.256	0.63	0.63	0.709	1.26	0.394	0.236	0.217	0.30	M6 x 1.0
16MM	0.630	0.335	0.748	0.748	0.709		0.472	0.236	0.217		M6 x 1.0
22 MM	0.866	0.413	1.00	1.00	0.866		0.709	0.236	0.217		M8 x 1.25

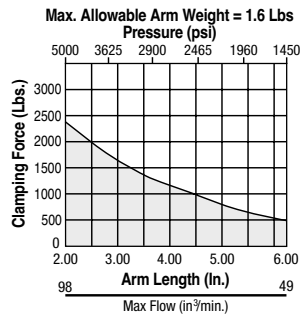
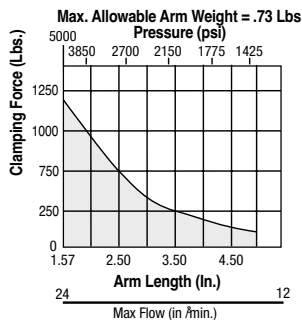
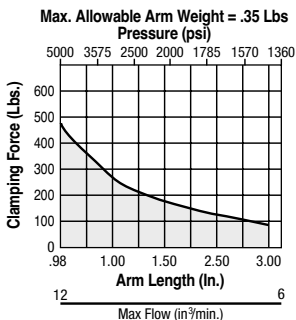
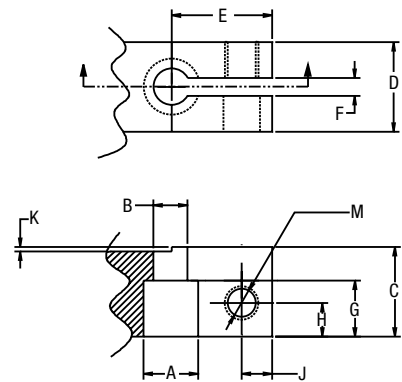

Chart Legend

- Maximum Length / Pressure
- ▭ Operating Range

Clamps must operate at or below maximum arm length/pressure curve:

To approximate clamping force with any arm at less than maximum pressure:

$$FORCE = P \times A \times [1 - (P/M \times .23)]$$

P = Hyd. system operating pressure (PSI)

A = Clamp effective area (sq. in.)

M = Max. rated pressure of chosen arm length (PSI)

Hydraulic Power Clamps | Hydraulic Swing Clamps – 4,000 lb. Arms

Custom built arms of any length must clamp to the swing clamp's piston rod in a manner similar to the DESTACO arms or some derating of the clamp will be necessary.

The design feature "K," in the chart and drawing at the bottom of this page, is recommended for all applications of custom, single arms. See the accompanying chart for design details. In applications where there is no bending stress being transferred into the piston rod (like push/pull linkages and equalizing double arms), this design detail may be eliminated. In these applications, the clamp's full capacity (referred to as "straight pull" capacity) is available.

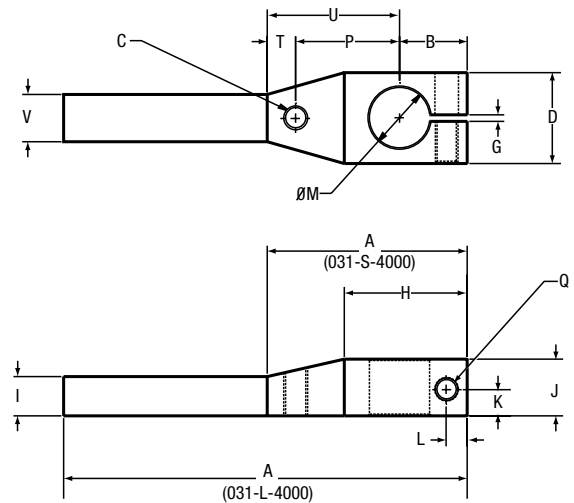

Cat no.	Specifications																Weight (lbs.)
	A	B	C	D	G	H	I	J	K	L	M	P	Q	T	U	V	
031-S-4000	4.17	1.42	1/2-13	1.89	0.138	2.56	0.83	1.18	0.55	0.43	1.26	2.17	M12	0.58	2.75	0.98	1.80
031-L-4000	8.43	1.42	1/2-13	1.89	0.138	2.56	0.83	1.18	0.55	0.43	1.26	-	M12	-	7.01	0.98	2.80

IMPORTANT: Any clamp using a modified or custom arm that is longer or heavier than DESTACO's standard arms must be derated to prevent internal damage.
Do not exceed the maximum speed and pressure ratings for DESTACO's standard arms.
For maximum hydraulic pressure and speed ratings, see the accompanying charts
Do not use meter-out circuitry for controlling double-acting clamp speeds
Contact DESTACO if further design assistance is required

Custom Arm Mounting Dimensions for 4,000 lb. Swing Clamps

Cat no.	Specifications							
	A	B	C	D	E	F	G	H
32MM	1.26	1.18	1.89	1.42	0.138	0.55	0.43	M12 x 1.75

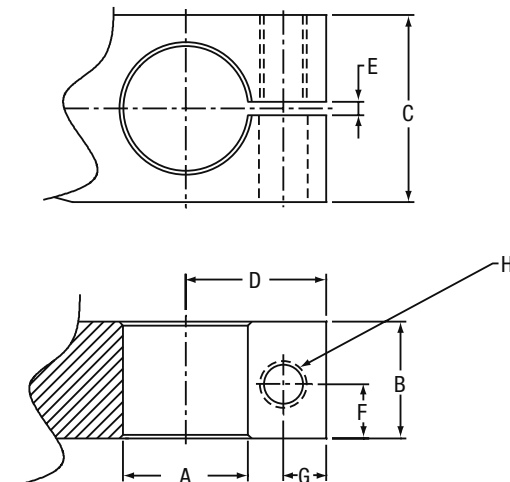

031-S-4000 • 031-L-4000

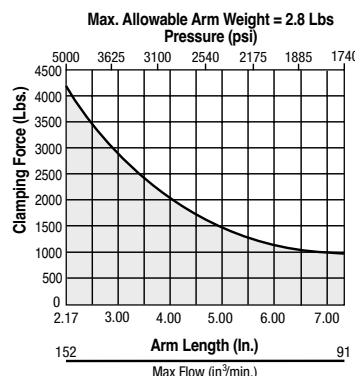

Chart Legend

- Maximum Length / Pressure
- ▭ Operating Range

Clamps must operate at or below maximum arm length/pressure curve:

To approximate clamping force with any arm at less than maximum pressure:

$$\text{FORCE} = P \times A \times [1 - (P/M \times .23)]$$

P = Hyd. system operating pressure (PSI)

A = Clamp effective area (sq. in.)

M = Max. rated pressure of chosen arm length (PSI)

039 SERIES

Hydraulic Power Clamps | Air/Hydraulic Power Boosters

The DESTACO Air/Hydraulic Power Booster converts normal shop-line air pressure to high-pressure hydraulic power. The two models available provide oil displacements ranging from 1 cu. in. to 4 cu. in. per stroke.

With the system filled, the volume of oil required to actuate a cylinder or pressure point is only equal to the cubic content of the piston displacement. The small booster, producing 1 cu. in. of usable oil per stroke, can operate 50 of the tiny 1/2-20 pressure points a full .22 max. stroke, and even more when strokes are kept to a minimum.

Features:

- Built-in manifold
- Complete automatic bleeding with each return stroke
- Automatic relief of system overcharge
- Automatic bleeding feature eliminates pre-filling
- Large volume visible oil reservoir automatically

replenishes the system with reserve oil capacity

- Corrosion and wear-resistant materials
- Wear rings on hydraulic piston tube
- Unique self-centering air piston assures long life
- Increases hydraulic pressure to 3,000 PSIG from 100 PSIG air-line pressure
- All models supplied with SAE hydraulic ports
- NPT hydraulic ports available on request



039-104-000DE

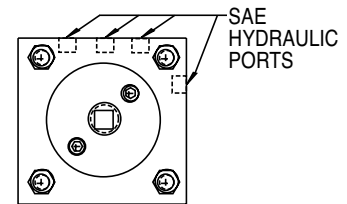
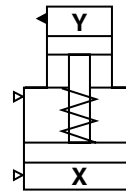

SAE HYDRAULIC PORTS

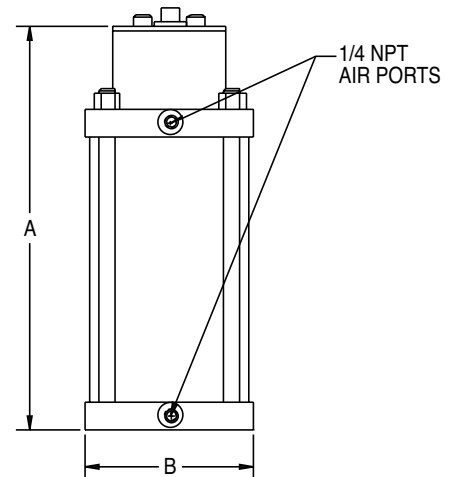

1/4 NPT AIR PORTS

Model no.	Press Ratio	Displacement Per Stroke	Nominal Reservoir Capacity	Weight	Dimensions		Ports
					A	B (Square)	
039-101-000DE	33.87:1	1 cu. in.	10.4 cu. in.	9 lbs.	10.88	4.50	SAE #4
039-104-000DE	32.41:1	4 cu. in.	42 cu. in.	23 lbs.	16.38	6.50	SAE #4

(100 PSIG max. input air pressure)

Note: Special High Temperature Seals available for applications where Viton® Seals are required. Order as H/T option.

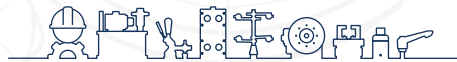

inf @ /CESEHSA.com.mx

