

## 96W Electric Products

01/28/2025



info@cesehsa.com.mx

cesehsa.com.mx



# 96W-1

Electric Pin Package | Pin Package | How to Order

96W-1 01 02 A4 60

Stroke	Description
40*	0-40 mm Stroke
60	0-60 mm Stroke

\*Straight motor option only.

Motor Connection	Description
00	Straight, without Drive
01	Straight, Rear Connections
02	Straight, Connections on Right
03	Straight, Connections on Left
10	Redirected, without Drive
11	Redirected, Rear Connections
12	Redirected, Connections on Right
13	Redirected, Connections on Left



Motor	Description
01	Servo Drive, Decentral 400 V
02	Servo Drive, Decentral 48 V

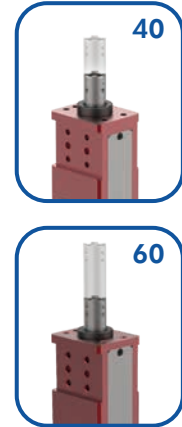
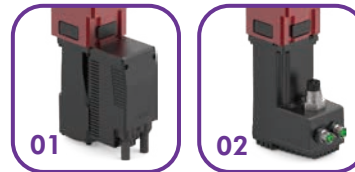

Piston Rod	Description
02*	Ø16 mm Cross Groove (*with M6 Threaded Inside Hole for Redirected Motor Connections 10, 11, 12, 13 see page 20)
04	NAAMS Standard
A4	NAAMS Standard Rotated 180°
B4	NAAMS Standard Rotated 90°
C4	NAAMS Standard Rotated 270°
05	Ø10 mm Inside Hole, Cross Groove

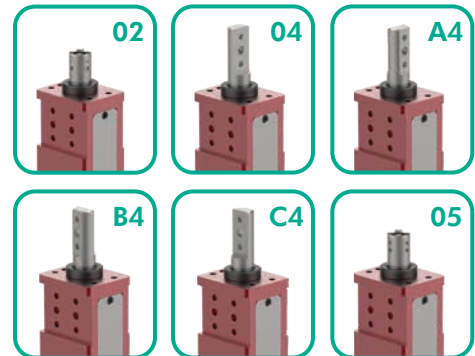

96W-111010260

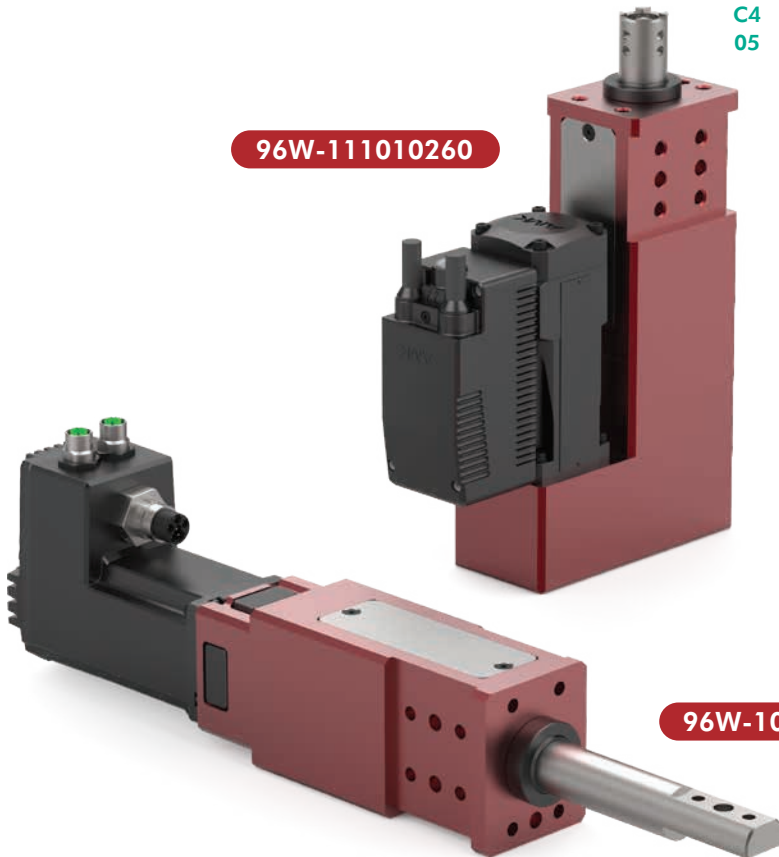

96W-10102A460

## Electric Pin Package | Pin Package | Dimensions | Technical Specifications

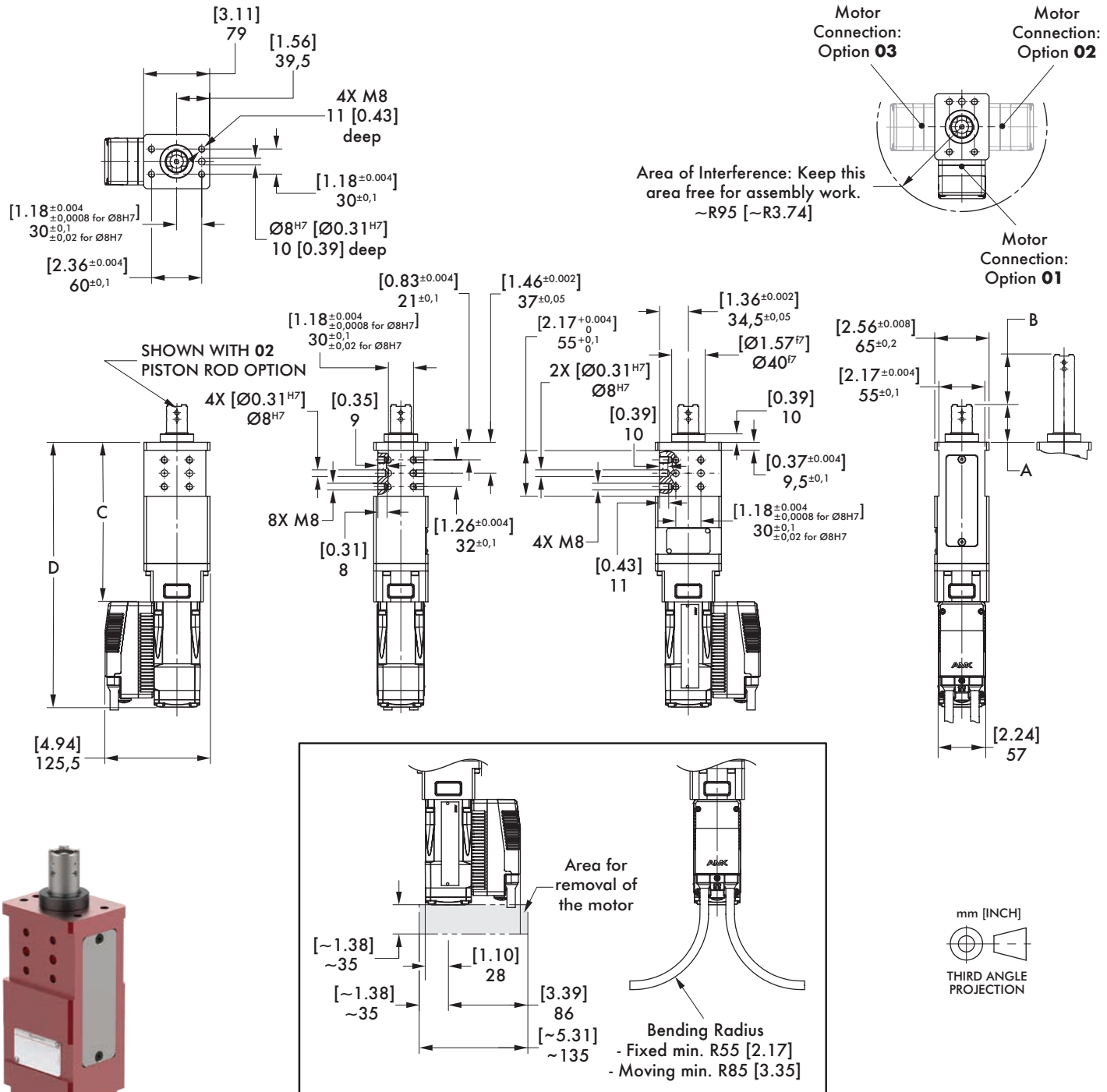

Base Model	Stroke B mm [in]	Thrust Force N [lbf]	Retraction Force N [lbf]	Speed Max. mm/s [in/s]	Weight Kg [lbs]	A mm [in]	C mm [in]	D mm [in]
96W-10.010240 96W-10.010540	[0-1.57] 0-40	[225] 1000	[225] 1000	[2.36] 60	[9.48] 4,3	[1.77] 45	[6.73] 171	[11.69] 297
96W-10.01.440						[2.76] 70		
96W-10.010260 96W-10.010560	[0-2.36] 0-60	[225] 1000	[225] 1000	[2.36] 60	[10.14] 4,6	[1.77] 45	[7.52] 191	[12.48] 317
96W-10.01.460						[2.76] 70		

# 96W-10.02...0

Electric Pin Package | Pin Package | Dimensions | Technical Specifications

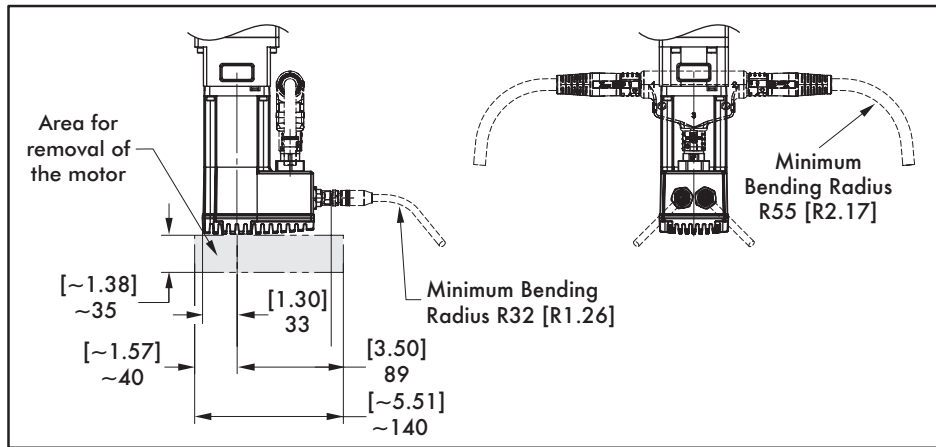
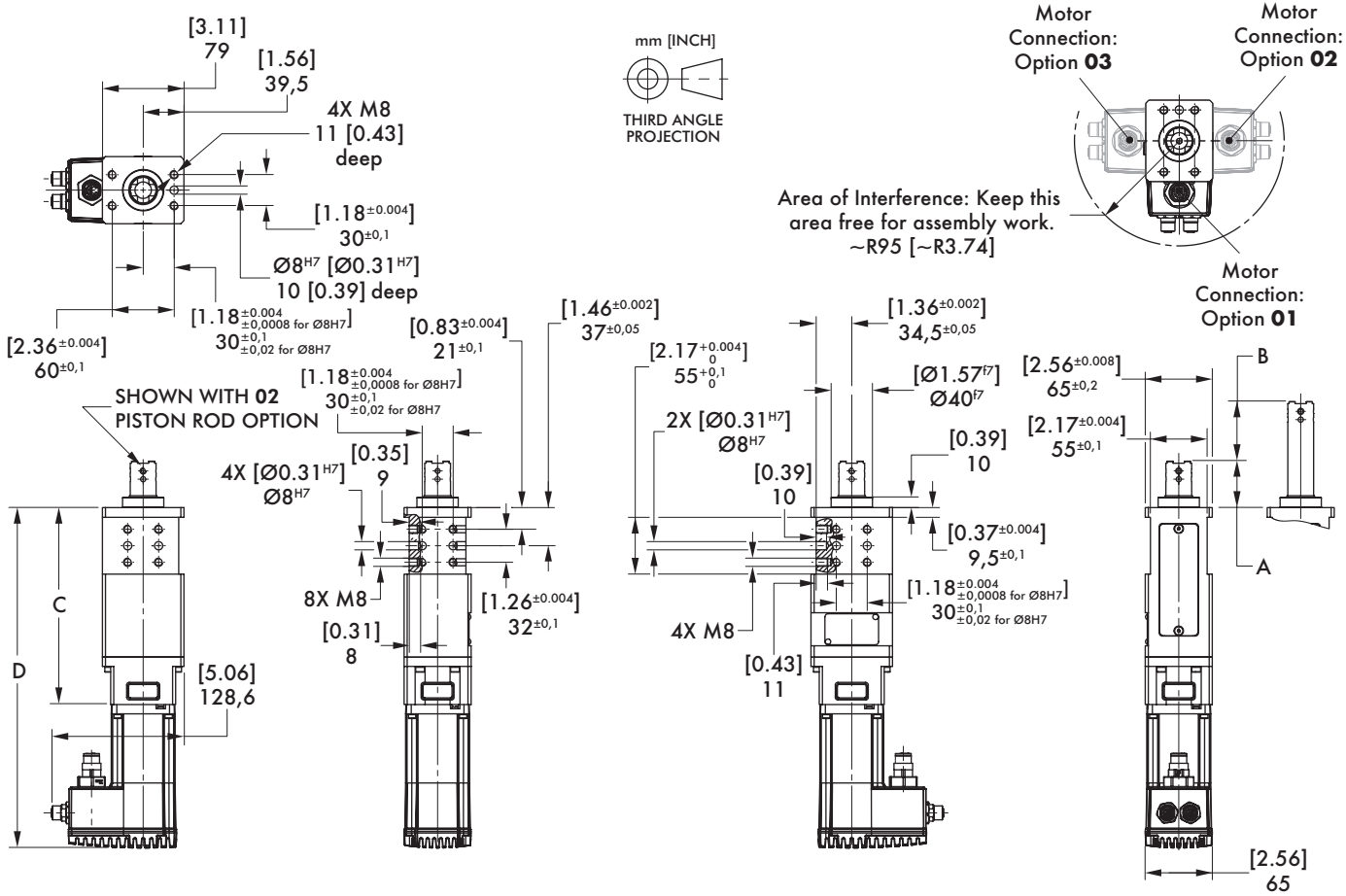

Base Model	Stroke B mm [in]	Thrust Force N [lbf]	Retraction Force N [lbf]	Speed Max. mm/s [in/s]	Weight Kg [lbs]	A mm [in]	C mm [in]	D mm [in]
96W-10.020240 96W-10.020540	[0-1.57] 0-40	[225] 1000	[225] 1000	[2.36] 60	[8.82] 4,0	[1.77] 45	[6.73] 171	[12.20] 310
96W-10.02.440						[2.76] 70		
96W-10.020260 96W-10.020560	[0-2.36] 0-60	[225] 1000	[225] 1000	[2.36] 60	[9.48] 4,3	[1.77] 45	[7.52] 191	[12.99] 330
96W-10.02.460						[2.76] 70		

## Electric Pin Package | Pin Package | Dimensions | Technical Specifications

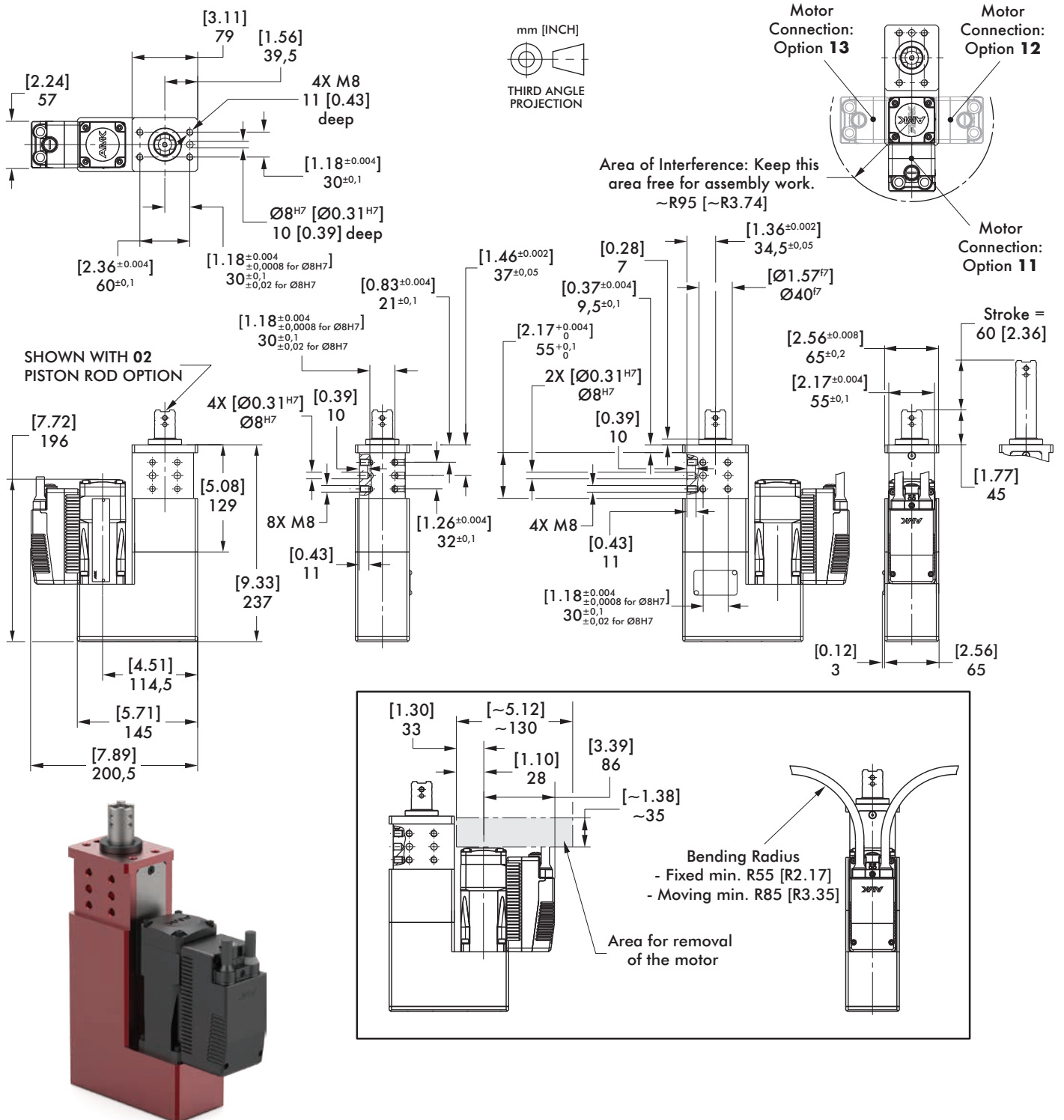

Base Model	Stroke mm [in]	Thrust Force N [lbf]	Retraction Force N [lbf]	Speed Max. mm/s [in/s]	Weight Kg [lbs]
96W-11.01..60	[0-2.36] 0-60	[225] 1000	[225] 1000	[2.36] 60	[14,33] 6,5

# 96W-11.02..60

Electric Pin Package | Pin Package | Dimensions | Technical Specifications

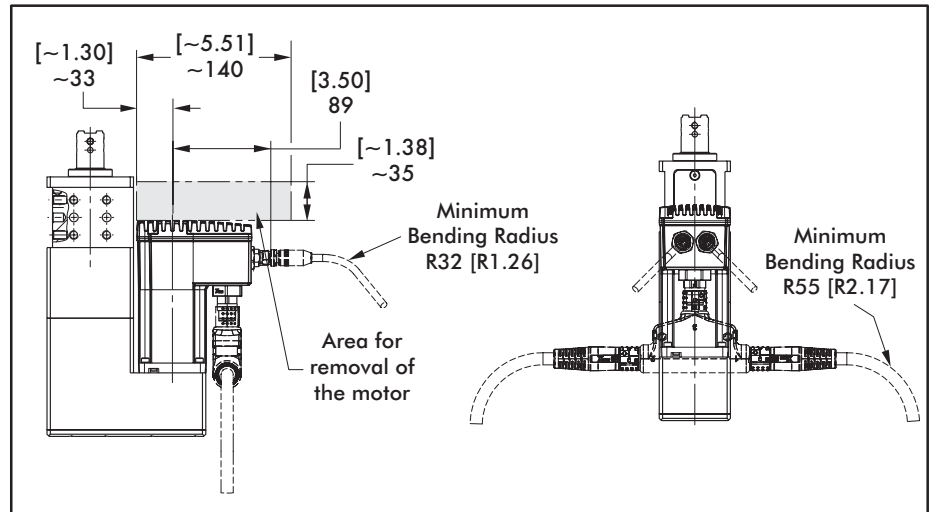
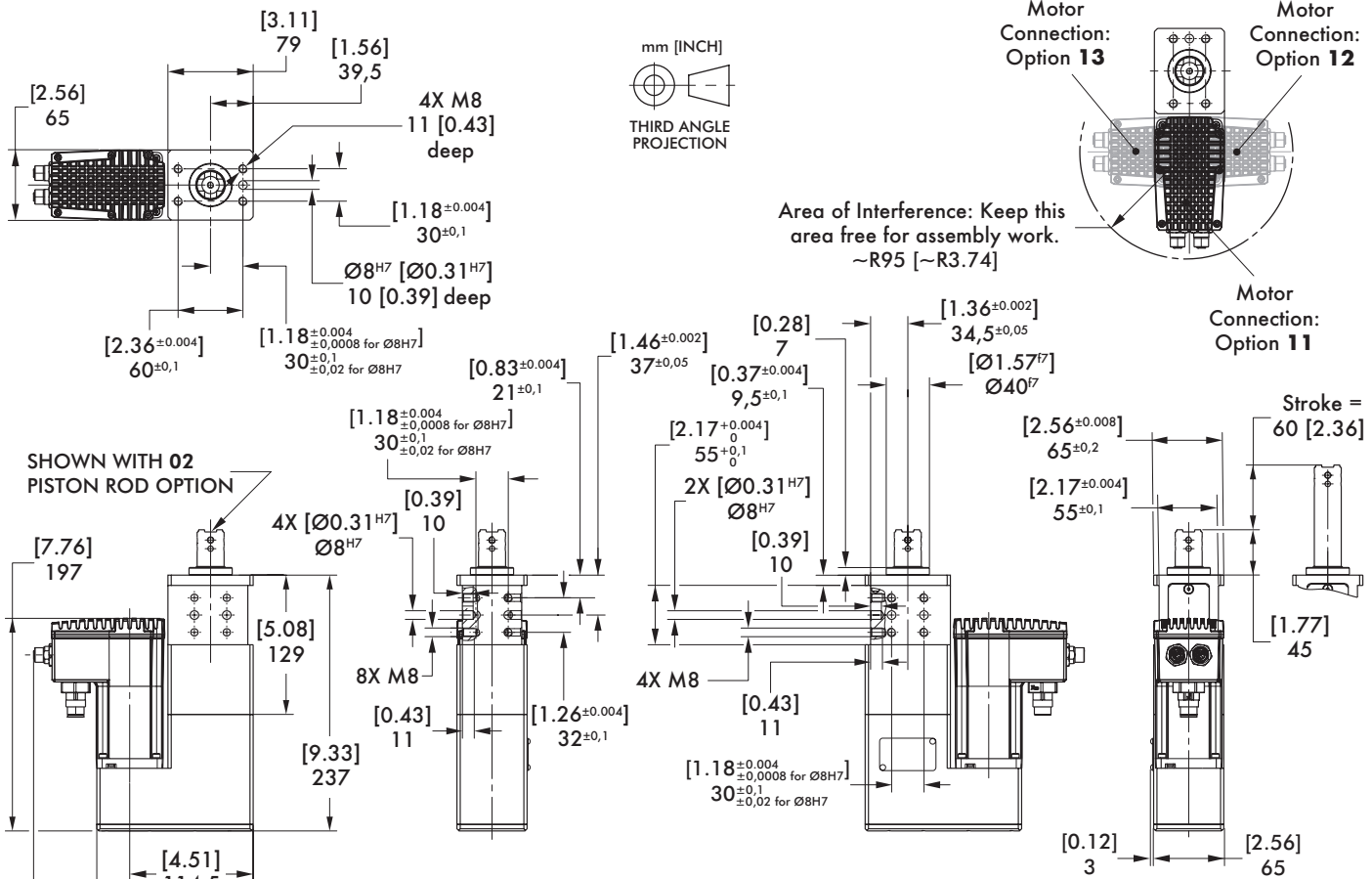

Base Model	Stroke mm [in]	Thrust Force N [lbf]	Retraction Force N [lbf]	Speed Max. mm/s [in/s]	Weight Kg [lbs]
96W-11.02..60	[0-2.36] 0-60	[225] 1000	[225] 1000	[2.36] 60	[13.01] 5,9



# 96W-1 PISTON RODS

Electric Pin Package | Pin Package | Dimensions

## 02 Ø16 mm, Cross Groove

for Straight Motor Option 00, 01, 02 or 03 only

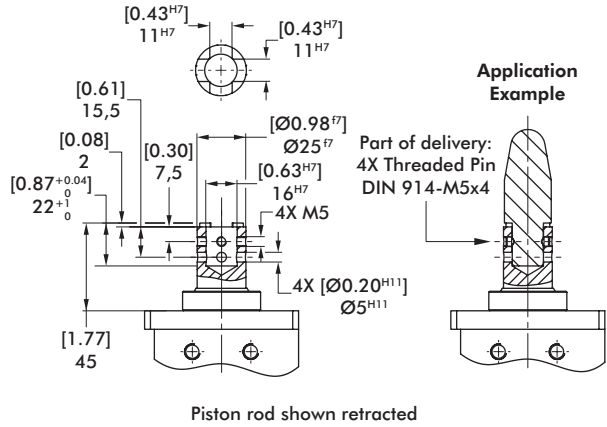

with M6 Threaded Inside Hole for Redirected Motor Option 10, 11, 12 or 13 only

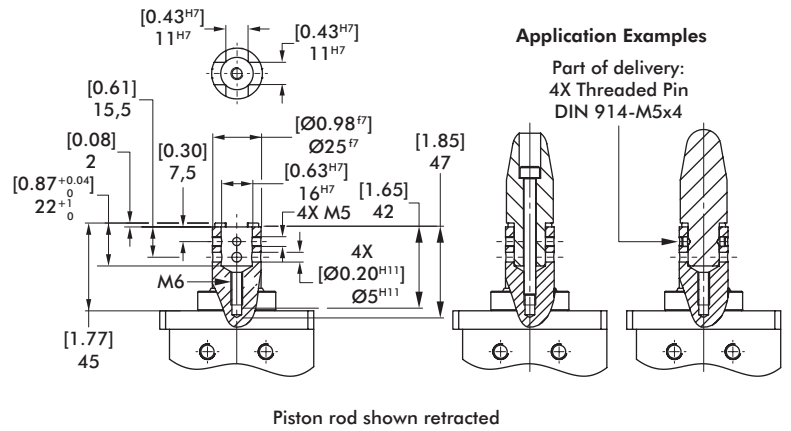

## 04, A4, B4, C4 NAAMS Standard

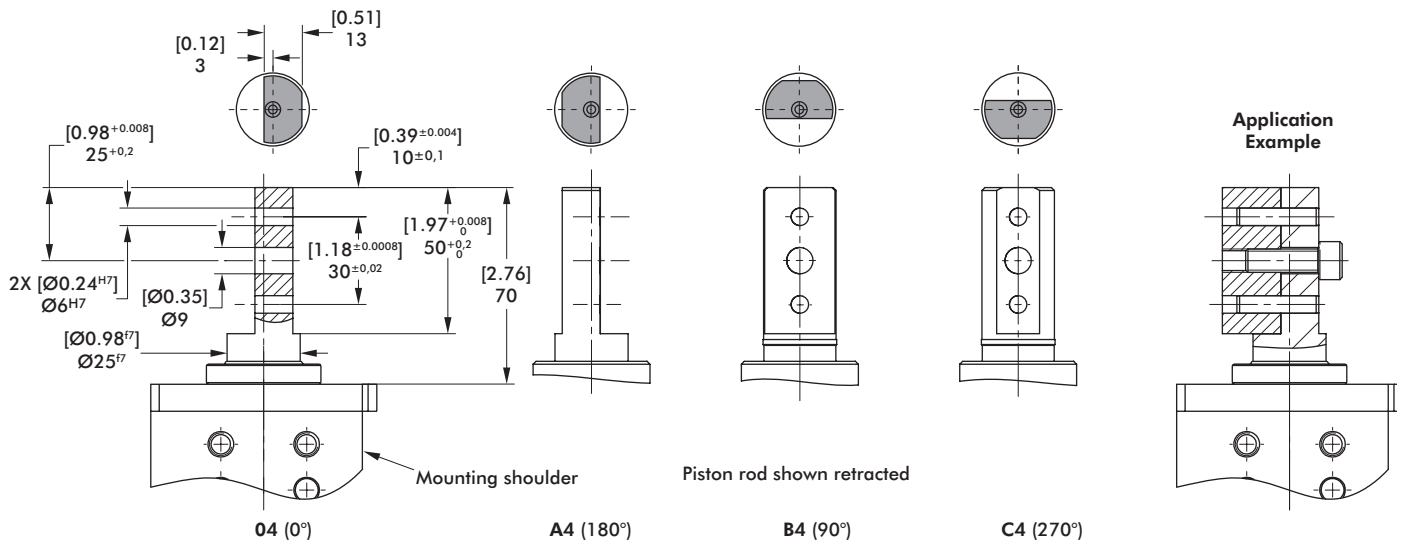

## 05 Ø10 mm Inside Hole, Cross Groove

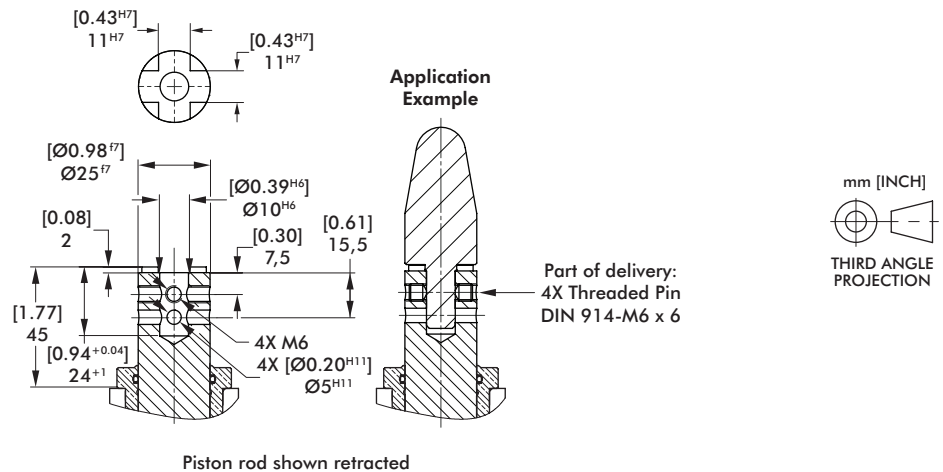

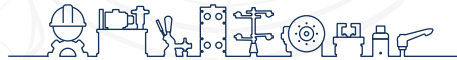

inf @ /CESEHSA.com.mx

