

Clamping

01/03/2025

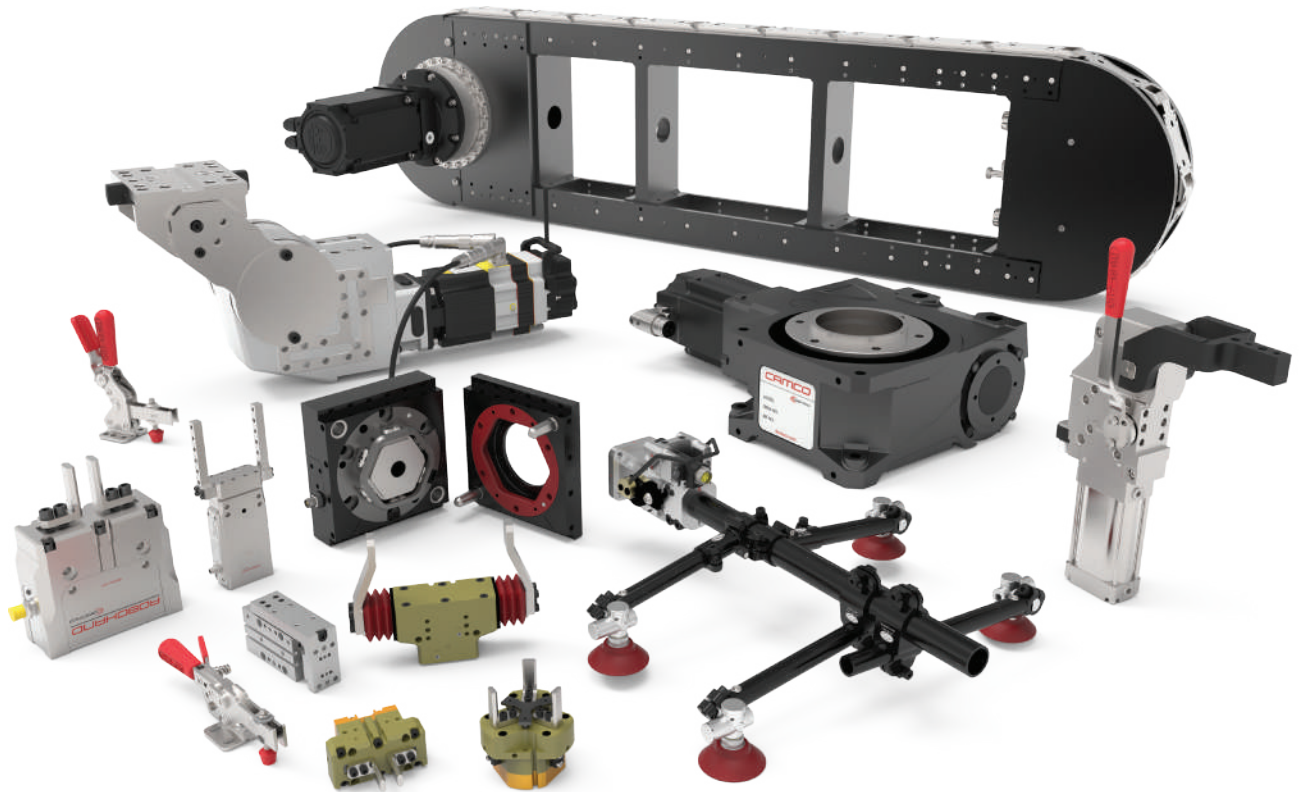

Clamping

01/03/2025

This catalog is a custom document and the products included is based on your unique selection from portions of complete catalogs that already exist. Please refer to our full catalogs for more information on products not included in this customized document.

Table of Contents

Horizontal Hold-Down Clamps

MC-HHD-1

Table of Contents (continued)

2013 SERIES

Horizontal Hold Down Clamps | Product Overview

Features:

- Increased handle clearance reduces pinch points
- Common mounting hole pattern to Model 213
- Fixed handle pivot provides smooth action
- Nearly 2 times the holding capacity Model 213
- BLK models feature a black, non-reflective finish
- 5 handle colors - see page MC-PRO-7 for details

Applications:

- Checking fixtures
- Assembly & test
- Light machining
- Woodworking
- Closures

Also Available:

See page MC-ACC-1 for accessories
Accommodates M5 or #10 spindle accessory

Covered under one or more U.S./International Patents

2013-U
Flanged Base
U-Bar



2013-U-LS-BLK ⓘ
Blackout Series
Flanged Base
U-Bar



2013-UR
Flanged Base
U-Bar
DESTACO®
Toggle Lock
Plus™



Color Handles
Available on models in this series that use standard red handles.* Add **-Y, -G, -B, -K** to end of model number.

*Excludes Blackout Series, Toggle Lock Plus levers.



ⓘ This item is available upon request

Technical Information

| Model | Max. Holding Capacity | Clamp Bar Opening (+10°) | Handle Opening (+10°) | Weight | Accessories (Supplied) | |
|-----------------|-----------------------|--------------------------|-----------------------|-------------------|------------------------|-----------------|
| | | | | | Spindle Assembly | Flanged Washers |
| 2013-U | 1310 N [295 lbf] | 71° | 58° | 0,17 kg [0.37 lb] | 2013208-M | 102111 |
| 2013-U-LS-BLK ⓘ | | | | | -- | 102111-BLK |
| 2013-UR | | | | | 2013208-M | 102111 |

ⓘ This item is available upon request

Holding Capacities

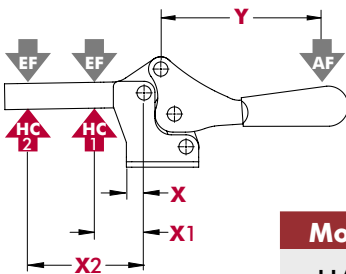

| Model | X | X1 | X2 | Y | ‡HC1 | ‡HC2 | ‡EF(X1):AF | ‡EF(X2):AF |
|-------|--------------|--------------|----------------|----------------|---------------------|--------------------|------------|------------|
| U/UR | [0.63] 16 | [0.95] 24 | [1.95] 49,5 | [2.34] 59,5 | [295 lbf] 1310 N | [175 lbf] 780 N | 6:1 | 4:1 |

Dimensions shown "mm [inch]" ‡ HC = Holding Capacity, EF = Exerting Force, AF = Applied Force
See page MC-TEC-4 for additional information.

2013-U
Flanged Base
U-Bar

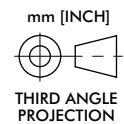
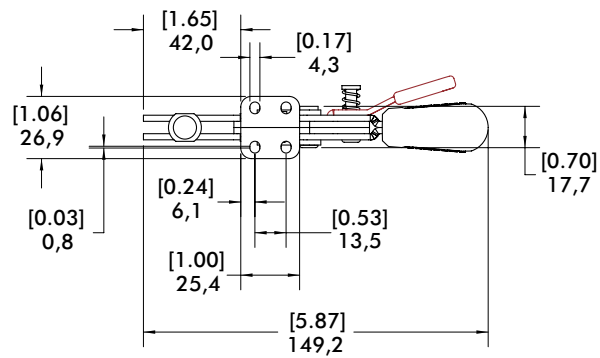
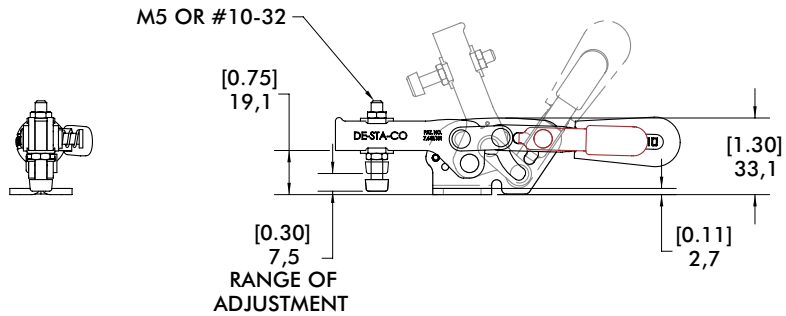
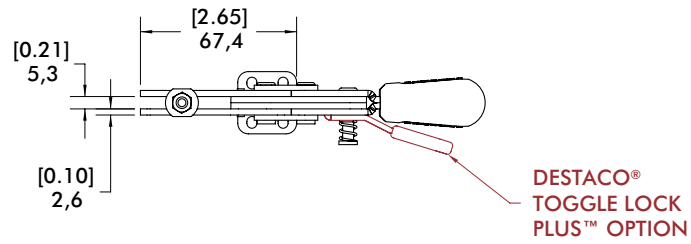

2017 SERIES

Horizontal Hold Down Clamps | Product Overview

Features:

- Increased handle clearance reduces pinch points
- Common mounting hole pattern to Model 217
- Fixed handle pivot provides smooth action
- Over 2½ times the holding capacity Model 217
- BLK models feature a black, non-reflective finish
- 5 handle colors - see page MC-PRO-7 for details

Applications:

- Checking fixtures
- Assembly & test
- Light machining
- Woodworking
- Closures

Also Available:

See page MC-ACC-1 for accessories
Accommodates M6 or ¼" spindle accessory

Covered under one or more U.S./International Patents

2017-U
Flanged Base
U-Bar



2017-U-LS-BLK ⓘ
Blackout Series
Flanged Base
U-Bar



2017-UR
Flanged Base
U-Bar
DESTACO®
Toggle Lock
Plus™



Color Handles
Available on models in this series that use standard red handles.* Add -Y, -G, -B, -K to end of model number.

*Excludes Blackout Series, Toggle Lock Plus levers.



ⓘ This item is available upon request

Technical Information

| Model | Max. Holding Capacity | Clamp Bar Opening (+10°) | Handle Opening (+10°) | Weight | Accessories (Supplied) | |
|-----------------|-----------------------|--------------------------|-----------------------|-------------------|------------------------|-----------------|
| | | | | | Spindle Assembly | Flanged Washers |
| 2017-U | 2500 N [560 lbf] | 73° | 69° | 0,44 kg [0.97 lb] | 215208-M | 215105 |
| 2017-U-LS-BLK ⓘ | | | | | -- | 215105-BLK |
| 2017-UR | | | | | 215208-M | 215105 |

ⓘ This item is available upon request

Holding Capacities

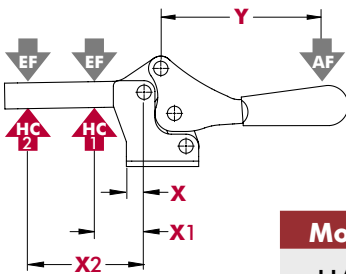

| Model | X | X1 | X2 | Y | ‡HC1 | ‡HC2 | ‡EF(X1):AF | ‡EF(X2):AF |
|-------|----------------|--------------|--------------|----------------|---------------------|---------------------|------------|------------|
| U/UR | [1.08] 27,4 | [1.65] 42 | [3.15] 80 | [2.54] 64,5 | [560 lbf] 2500 N | [245 lbf] 1090 N | 5:1 | 2.5:1 |

Dimensions shown "mm [inch]" ‡ HC = Holding Capacity, EF = Exerting Force, AF = Applied Force
See page MC-TEC-4 for additional information.

2017-U
Flanged Base
U-Bar

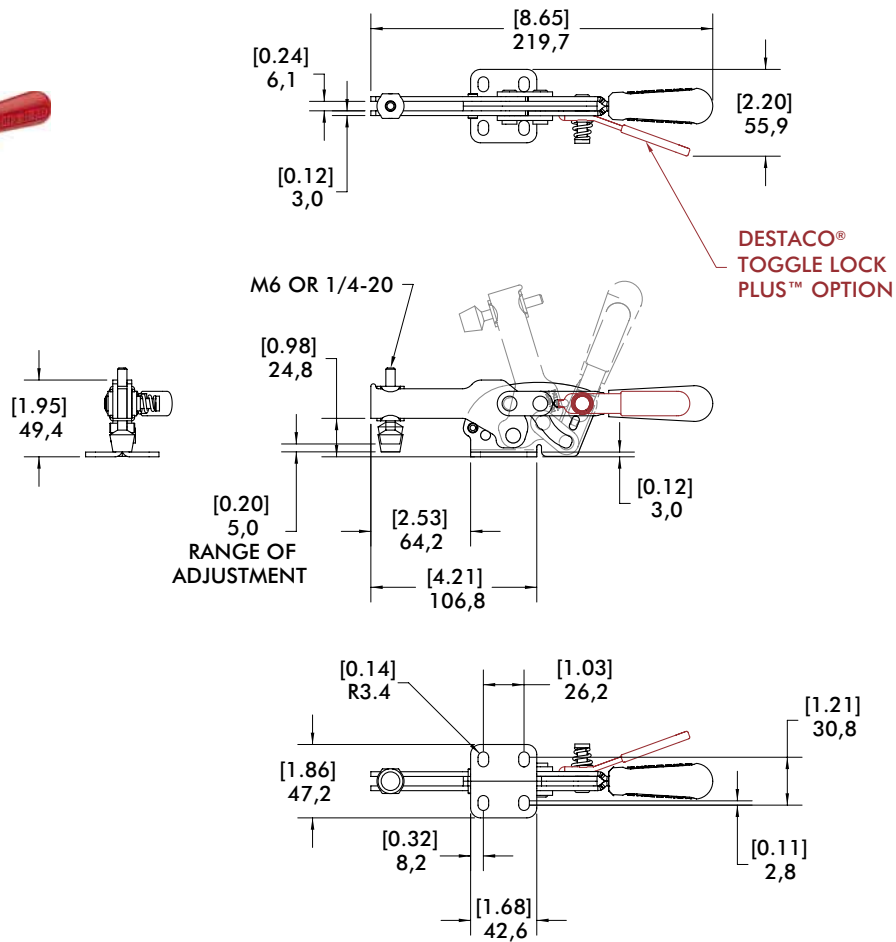

2027 SERIES

Horizontal Hold Down Clamps | Product Overview

Features:

- Increased handle clearance reduces pinch points
- Common mounting hole pattern to Model 227
- Fixed handle pivot provides smooth action
- Over 1½ times the holding capacity Model 227
- BLK models feature a black, non-reflective finish
- 5 handle colors - see page MC-PRO-7 for details

Applications:

- Checking fixtures
- Assembly & test
- Light machining
- Woodworking
- Closures

Also Available:

See page MC-ACC-1 for accessories
Accommodates M8 or 5/16" spindle accessory

Covered under one or more U.S./International Patents

2027-U
Flanged Base
U-Bar



2027-U-LS-BLK ⓘ
Blackout Series
Flanged Base
U-Bar



2027-UR
Flanged Base
U-Bar
DESTACO®
Toggle Lock
Plus™



Color Handles
Available on models in this series that use standard red handles.* Add **-Y, -G, -B, -K** to end of model number.

*Excludes Blackout Series, Toggle Lock Plus levers.



ⓘ This item is available upon request

Technical Information

| Model | Max. Holding Capacity | Clamp Bar Opening (+10°) | Handle Opening (+10°) | Weight | Accessories (Supplied) | |
|-----------------|-----------------------|--------------------------|-----------------------|-------------------|------------------------|-----------------|
| | | | | | Spindle Assembly | Flanged Washers |
| 2027-U | 3740 N [840 lbf] | 68° | 70° | 0,61 kg [1.34 lb] | 2007208-M | 507107 |
| 2027-U-LS-BLK ⓘ | | | | | -- | 507107-BLK |
| 2027-UR | | | | | 2007208-M | 507107 |

ⓘ This item is available upon request

Holding Capacities

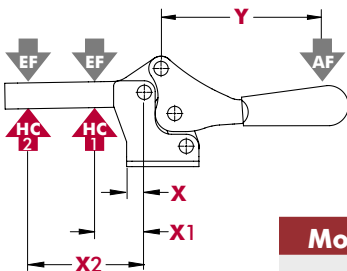

| Model | X | X1 | X2 | Y | ‡HC1 | ‡HC2 | ‡EF(X1):AF | ‡EF(X2):AF |
|-------|----------------|----------------|----------------|----------------|---------------------|---------------------|------------|------------|
| U/UR | [1.02] 25,8 | [1.75] 44,5 | [3.30] 83,8 | [2.54] 64,5 | [840 lbf] 3740 N | [480 lbf] 2140 N | 5:1 | 3:1 |

Dimensions shown "mm [inch]" ‡ HC = Holding Capacity, EF = Exerting Force, AF = Applied Force
See page MC-TEC-4 for additional information.

2027 SERIES

Horizontal Hold Down Clamps | Dimensions | -U/-UR

2027-U
Flanged Base
U-Bar

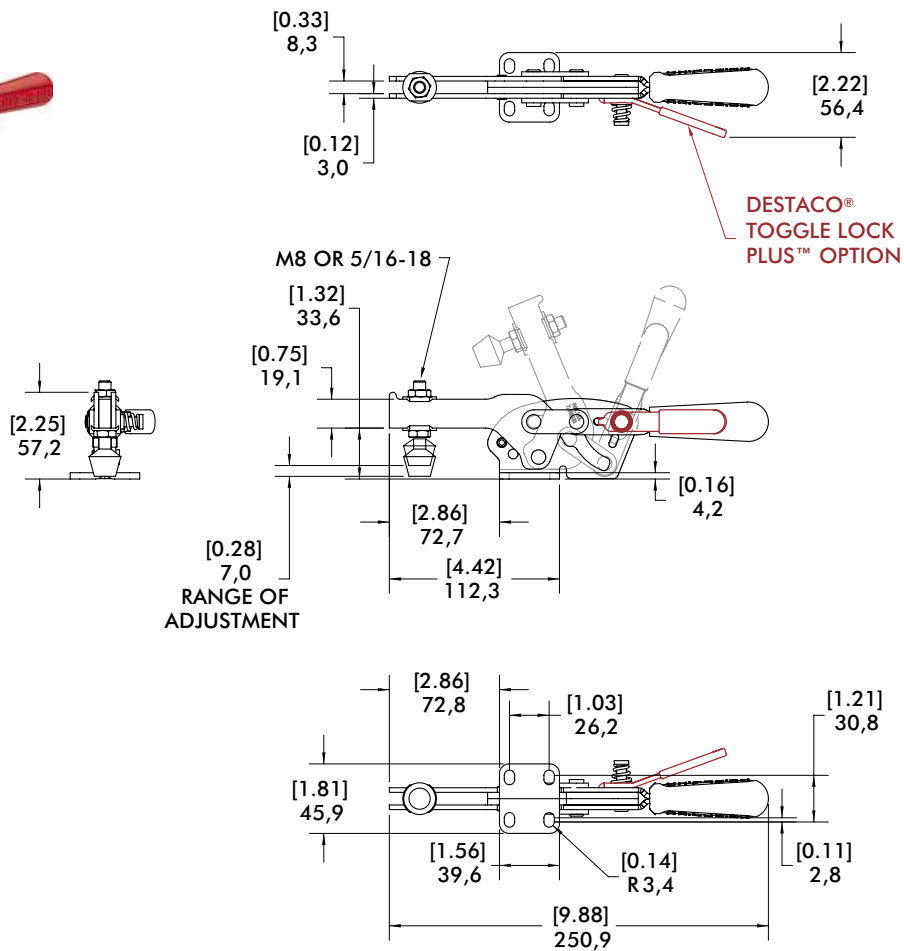

mm [INCH]
THIRD ANGLE PROJECTION

213 SERIES

Horizontal Hold Down Clamps | Product Overview

Features:

- Low profile
- Large handle clearance in the open position
- Available in stainless steel
- BLK models feature a black, non-reflective finish
- 5 handle colors - see page MC-PRO-7 for details

Applications:

- Assembly
- Checking fixtures
- Closures
- Woodworking

Also Available:

See page MC-ACC-1 for accessories
Accommodates M5 or #10 spindle accessory

213-U/USS
Flanged Base
U-Bar



-USS Stainless Steel Model

213-U-LS-BLK ⓘ
Blackout Series
Flanged Base
U-Bar

213-UB
Straight Base
U-Bar

213-UB-LS-BLK ⓘ
Blackout Series
Straight Base
U-Bar

213-U-L ⓘ
Flanged Base
Open Bar



213-U-L-BLK ⓘ
Flanged Base
Open Bar

213-UB-L ⓘ
Straight Base
Open Bar

213-UB-L-BLK ⓘ
Blackout Series
Straight Base
Open Bar



Color Handles

Available on models in this series that use standard red handles* Add -Y, -G, -B, -K to end of model number.

*Excludes Blackout Series.



ⓘ This item is available upon request

Technical Information

| Model | Max. Holding Capacity | Clamp Bar Opening (+10°) | Handle Opening (+10°) | Weight | Accessories (Supplied) | |
|-----------------|-----------------------|--------------------------|-----------------------|-------------------|------------------------|-----------------|
| | | | | | Spindle Assembly | Flanged Washers |
| 213-U | 670 N [150 lbf] | 90° | 60° | 0,08 kg [0.17 lb] | 213208-M | 102111 |
| 213-U-LS-BLK ⓘ | | | | | -- | 102111-BLK |
| 213-USS | | | | | 201943-M | 102911 |
| 213-UB | | | | | 213208-M | 102111 |
| 213-UB-LS-BLK ⓘ | | | | | -- | 102111-BLK |
| 213-U-L ⓘ | | | | | | 102111 |
| 213-U-L-BLK ⓘ | | | | | | 102111-BLK |
| 213-UB-L ⓘ | | | | | | 102111 |
| 213-UB-L-BLK ⓘ | | | | | 102111-BLK | |

ⓘ This item is available upon request

213 SERIES

Horizontal Hold Down Clamps | Holding Capacities

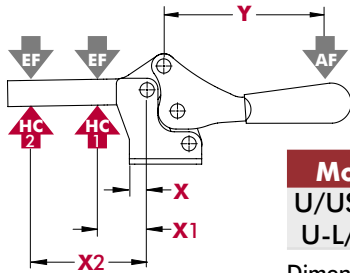

| Model | X | X1 | X2 | Y | ±HC1 | ±HC2 | ±EF(X1):AF | ±EF(X2):AF |
|----------|--------|--------|--------|--------|-----------|----------|------------|------------|
| U/USS/UB | [0.36] | [0.75] | [1.63] | [1.81] | [150 lbf] | [70 lbf] | 7:1 | 3:1 |
| U-L/UB-L | 9,3 | 19 | 41,4 | 46 | 670 N | 310 N | | |

Dimensions shown "mm [inch]" ± HC = Holding Capacity, EF = Exerting Force, AF = Applied Force
See page MC-TEC-4 for additional information.

Dimensions | -U/-USS/-UB

213-U Flanged Base U-Bar

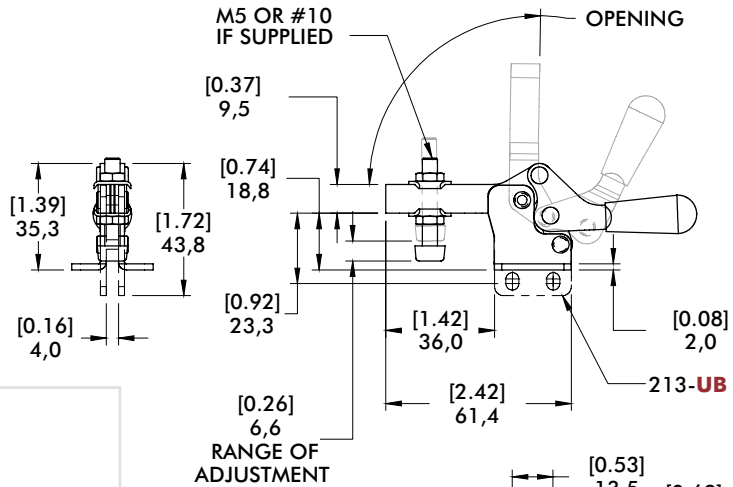
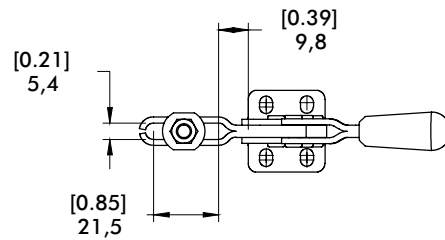

Series 213 Open Bar Options



Flanged Base Model 213-U-L ⓘ

See page MC-ACC-7 for Complete offering of Open bar accessories

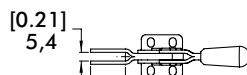

Straight Base Model 213-UB-L ⓘ

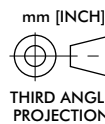
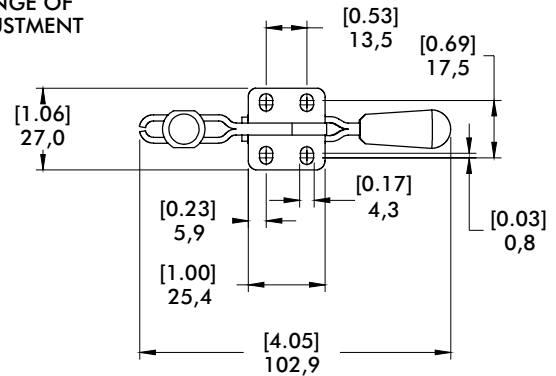
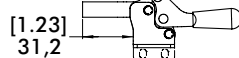

217 SERIES

Horizontal Hold Down Clamps | Product Overview

Features:

- Low profile
- Large handle clearance in the open position
- Available in stainless steel
- BLK models feature a black, non-reflective finish
- 5 handle colors - see page MC-PRO-7 for details

Applications:

- Assembly
- Checking fixtures
- Closures
- Woodworking

Also Available:

See page MC-ACC-1 for accessories
Accommodates M6 or 1/4" spindle accessory

217-U/USS
Flanged Base
U-Bar



-USS Stainless Steel Model



217-U-LS-BLK ⓘ
Blackout Series
Flanged Base
U-Bar



217-UB
Straight Base
U-Bar



217-UB-LS-BLK ⓘ
Blackout Series
Straight Base
U-Bar



217-U-L ⓘ
Flanged Base
Open Bar



217-U-L-BLK ⓘ
Flanged Base
Open Bar



217-UB-L ⓘ
Straight Base
Open Bar



217-UB-L-BLK ⓘ
Blackout Series
Straight Base
Open Bar



Color Handles

Available on models in this series that use standard red handles.* Add -Y, -G, -B, -K to end of model number.



ⓘ This item is available upon request

*Excludes Blackout Series.

Technical Information

| Model | Max. Holding Capacity | Clamp Bar Opening (+10°) | Handle Opening (+10°) | Weight | Accessories (Supplied) | |
|-----------------|-----------------------|--------------------------|-----------------------|-------------------|------------------------|-----------------|
| | | | | | Spindle Assembly | Flanged Washers |
| 217-U | 900 N [200 lbf] | 91° | 61° | 0,18 kg [0.40 lb] | 202208-M | 215105 |
| 217-U-LS-BLK ⓘ | | | | | -- | 215105-BLK |
| 217-USS | 202943-M | | | | 215105 | |
| 217-UB | 202208-M | | | | 215105 | |
| 217-UB-LS-BLK ⓘ | -- | | | | 215105-BLK | |
| 217-U-L ⓘ | | | | | 215105 | |
| 217-U-L-BLK ⓘ | | | | | 215105-BLK | |
| 217-UB-L ⓘ | | | | | 215105 | |
| 217-UB-L-BLK ⓘ | | 215105-BLK | | | | |

ⓘ This item is available upon request

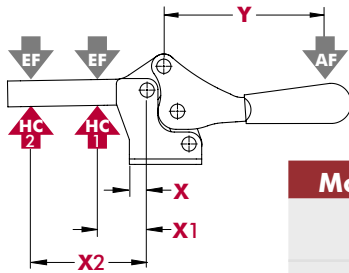

| Model | X | X1 | X2 | Y | ±HC1 | ±HC2 | ±EF(X1):AF | ±EF(X2):AF |
|-----------------|----------------|----------------|----------------|----------------|---------------------|--------------------|------------|------------|
| U | | | | | [200 lbf] 900 N | [80 lbf] 360 N | | |
| USS | [0.53] 13,5 | [1.13] 28,6 | [2.63] 66,8 | [2.93] 74,5 | [250 lbf] 1110 N | [100 lbf] 440 N | 7:1 | 3:1 |
| UB/U-L/ UB-L | | | | | [200 lbf] 900 N | [80 lbf] 360 N | | |

Dimensions shown "mm [inch]" ± HC = Holding Capacity, EF = Exerting Force, AF = Applied Force
See page MC-TEC-4 for additional information.

Dimensions | -U/-USS/-UB

Series 217 Open Bar Options



**Flanged Base
Model
217-U-L**



**Straight Base
Model
217-UB-L**

See page MC-ACC-7 for Complete offering of Open bar accessories

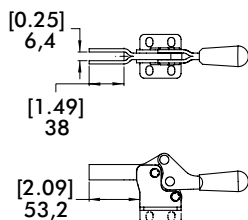

217-U Flanged Base U-Bar

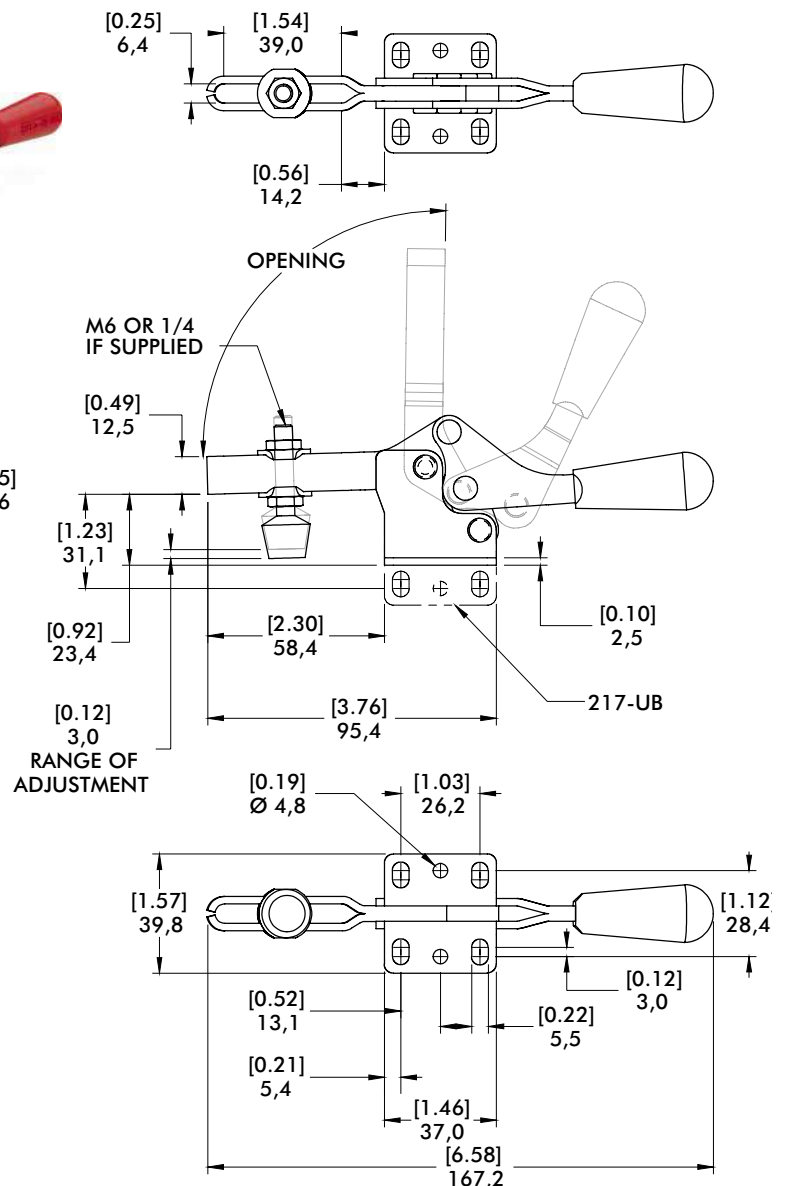
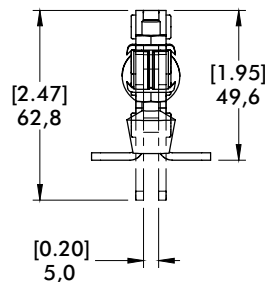

mm [INCH]
THIRD ANGLE
PROJECTION

227 SERIES

Horizontal Hold Down Clamps | Product Overview

Features:

- Low profile
- Large handle clearance in the open position.
- Available in stainless steel
- BLK models feature a black, non-reflective finish
- 5 handle colors - see page MC-PRO-7 for details

Applications:

- Assembly
- Checking fixtures
- Closures
- Woodworking

Also Available:

See page MC-ACC-1 for accessories
Accommodates M6 or 5/16" spindle accessory

227-U/USS
Flanged Base
U-Bar



-USS Stainless Steel Model

227-U-LS-BLK ⓘ
Blackout Series
Flanged Base
U-Bar

227-UB
Straight Base
U-Bar

227-UB-LS-BLK ⓘ
Blackout Series
Straight Base
U-Bar

227-U-L ⓘ
Flanged Base
Open Bar



227-U-L-BLK ⓘ
Flanged Base
Open Bar

227-UB-L ⓘ
Straight Base
Open Bar

227-UB-L-BLK ⓘ
Blackout Series
Straight Base
Open Bar

Color Handles

Available on models in this series that use standard red handles* Add -Y, -G, -B, -K to end of model number.

*Excludes Blackout Series.



ⓘ This item is available upon request

Technical Information

| Model | Max. Holding Capacity | Clamp Bar Opening (+10°) | Handle Opening (+10°) | Weight | Accessories (Supplied) | |
|-----------------|-----------------------|--------------------------|-----------------------|-------------------|------------------------|-----------------|
| | | | | | Spindle Assembly | Flanged Washers |
| 227-U | 2220 N [500 lbf] | 91° | 56° | 0,31 kg [0.68 lb] | 225208-M | 507107 |
| 227-U-LS-BLK ⓘ | | | | | -- | 507107-BLK |
| 227-USS | -207943-M | | | | 507907 | |
| 227-UB | 225208-M | | | | 507107 | |
| 227-UB-LS-BLK ⓘ | -- | | | | 507107-BLK | |
| 227-U-L ⓘ | | | | | 507107 | |
| 227-U-L-BLK ⓘ | | | | | 507107-BLK | |
| 227-UB-L ⓘ | | | | | 507107 | |
| 227-UB-L-BLK ⓘ | | 507107-BLK | | | | |

ⓘ This item is available upon request

227 SERIES

Horizontal Hold Down Clamps | Holding Capacities

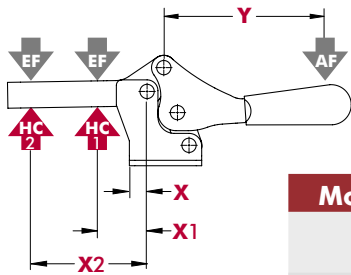

| Model | X | X1 | X2 | Y | ±HC1 | ±HC2 | ±EF(X1):AF | ±EF(X2):AF |
|-----------------|----------------|----------------|----------------|----------------|---------------------|---------------------|------------|------------|
| U | | | | | [500 lbf] 2220 N | [225 lbf] 1000 N | | |
| USS | [0.39] 10,0 | [1.25] 31,8 | [2.75] 70,0 | [3.58] 91,0 | [600 lbf] 2670 N | [270 lbf] 1200 N | 8:1 | 3:1 |
| UB/U-L/ UB-L | | | | | 500 lbf 2220 N | [225 lbf] 1000 N | | |

Dimensions shown "mm [inch]" ± HC = Holding Capacity, EF = Exerting Force, AF = Applied Force
See page MC-TEC-4 for additional information.

Dimensions | -U/-USS/-UB

227-U
Flanged Base
U-Bar

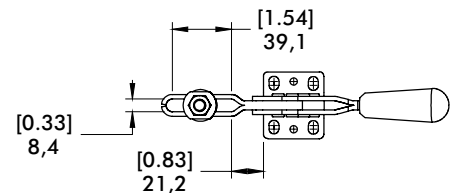

Series 227 Open Bar Options



Flanged Base
Model
227-U-L

See page MC-ACC-7 for Complete offering of Open bar accessories

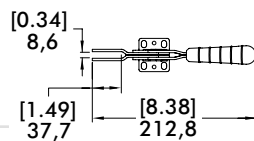

Straight Base
Model
227-UB-L

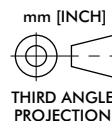
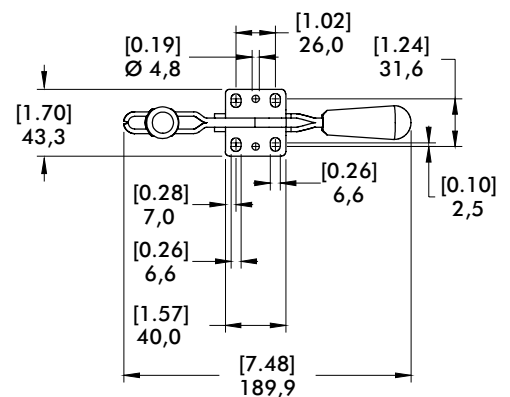
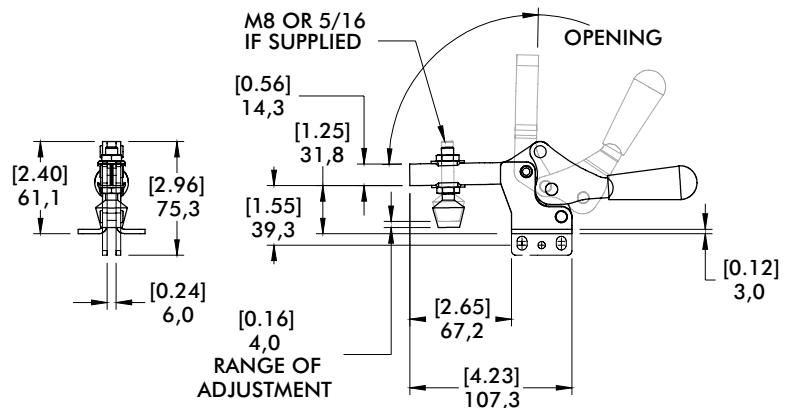
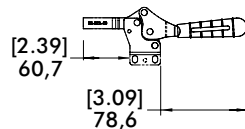

237 SERIES

Horizontal Hold Down Clamps | Product Overview

Features:

- Low profile
- Large handle clearance in the open position.
- Available in stainless steel
- 5 handle colors - see page MC-PRO-7 for details

Applications:

- Assembly
- Checking fixtures
- Welding

Also Available:

See page MC-ACC-1 for accessories
Accommodates M10 or 3/8" spindle accessory

237-U/USS Flanged Base U-Bar



-USS Stainless Steel Model



Color Handles
Available on this model.
Add **-Y**, **-G**, **-B**, **-K** to end of model number.



Technical Information

| Model | Max. Holding Capacity | Clamp Bar Opening(+10°) | Handle Opening (+10°) | Weight | Accessories (Supplied) | |
|-----------|-----------------------|-------------------------|-----------------------|-------------------|------------------------|-----------------|
| | | | | | Spindle Assembly | Flanged Washers |
| 237-U | 3340 N [750 lbf] | 93° | 59° | 0,73 kg [1.60 lb] | 240208-M | 235106 |
| 237-USS ⓘ | 3780 N [850 lbf] | | | | 237943-M | 235906 |

ⓘ This item is available upon request

Holding Capacities

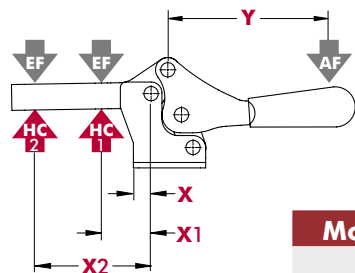

| Model | X | X1 | X2 | Y | ±HC1 | ±HC2 | ±EF(X1):AF | ±EF(X2):AF |
|-------|--------|--------|--------|--------|---------------------|---------------------|------------|------------|
| U | [0.81] | [1.75] | [4.50] | [5.25] | [750 lbf] 3340 N | [290 lbf] 1290 N | 6:1 | 2:1 |
| USS | 20,6 | 44,5 | 114,3 | 133,3 | [850 lbf] 3780 N | [330 lbf] 1470 N | | |

Dimensions shown "mm [inch]" ± HC = Holding Capacity, EF = Exerting Force, AF = Applied Force
See page MC-TEC-4 for additional information.

237-U
Flanged Base
U-Bar

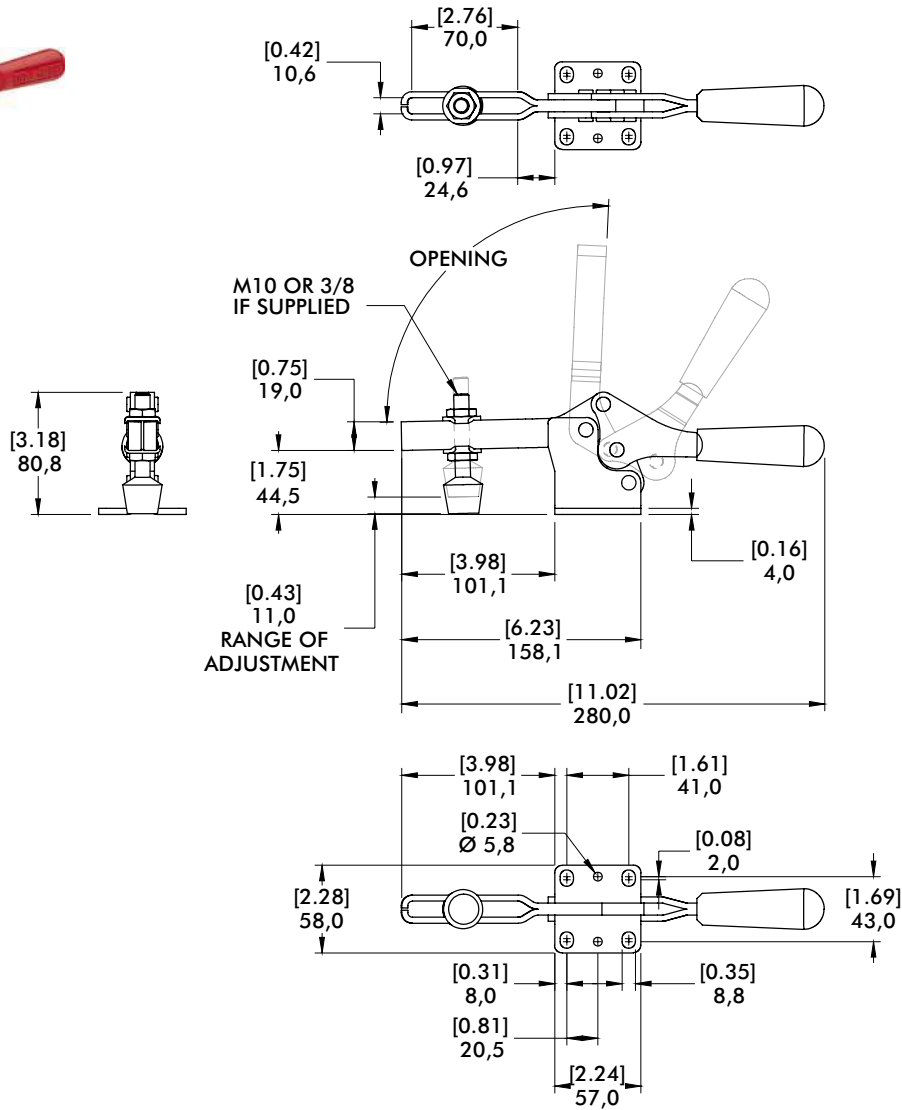

245 SERIES

Horizontal Hold Down Clamps | Product Overview

Features:

- Low profile
- Large handle clearance in the open position.

Applications:

- Assembly
- Checking fixtures
- Welding

Also Available:

See page MC-ACC-1 for accessories
Accommodates M12 or 1/2" spindle accessory

245-U
Flanged Base
U-Bar



Technical Information

| Model | Max. Holding Capacity | Clamp Bar Opening (+10°) | Handle Opening (+10°) | Weight | Accessories (Supplied) | |
|-------|-----------------------|--------------------------|-----------------------|-------------------|------------------------|-----------------|
| | | | | | Spindle Assembly | Flanged Washers |
| 245-U | 4450 N [1000 lbf] | 105° | 74° | 1,32 kg [2.90 lb] | 247208-M | 247109 |

Holding Capacities

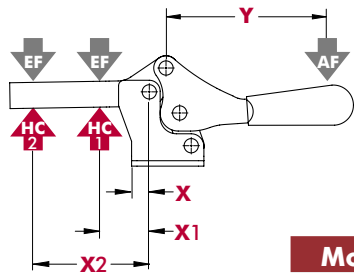

| Model | X | X1 | X2 | Y | ±HC1 | ±HC2 | ±EF(X1):AF | ±EF(X2):AF |
|-------|----------------|----------------|---------------|-----------------|----------------------|---------------------|------------|------------|
| U | [0.50] 12,7 | [2.00] 50,8 | [5.00] 127 | [6.09] 154,7 | [1000 lbf] 4450 N | [400 lbf] 1780 N | 11:1 | 5:1 |

Dimensions shown "mm [inch]" ‡ **HC** = Holding Capacity, **EF** = Exerting Force, **AF** = Applied Force
See page MC-TEC-4 for additional information.

245-U
Flanged Base
U-Bar

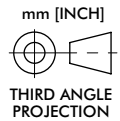
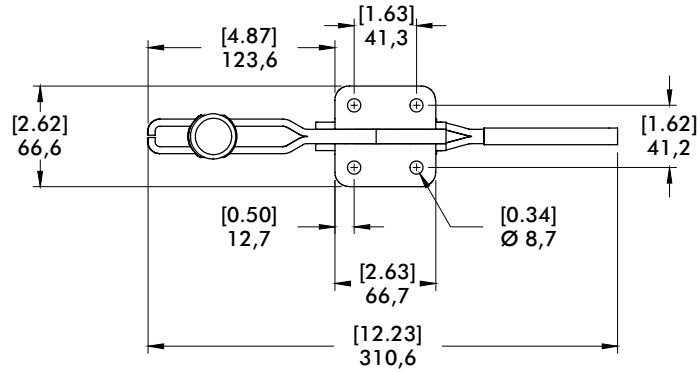
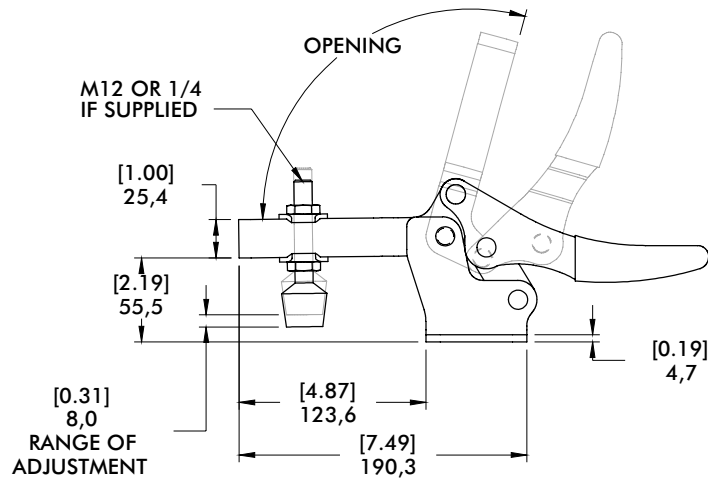
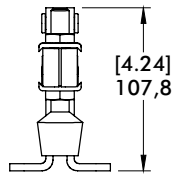
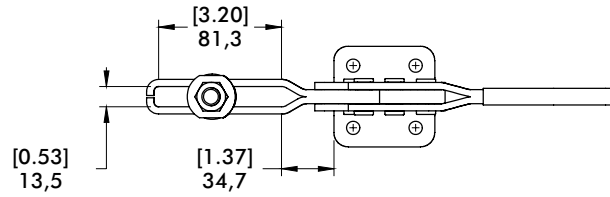

205 SERIES

Horizontal Hold Down Clamps | Product Overview

Features:

- Smallest of the Horizontal Hold Down clamps
- Ideal for light duty clamping in tight spaces
- Stainless steel models furnished without plastic grip

Applications:

- Assembly
- Closures
- Woodworking
- Light duty clamping

Also Available:

See page MC-ACC-1 for accessories
Accommodates M4 or #8 spindle accessory

205-U/USS
Flanged Base
U-Bar



-USS Stainless Steel Model

205-UB ⓘ
Straight Base
U-Bar



205-UL ⓘ
Left Flanged Base
U-Bar



205-UR ⓘ
Right Flanged Base
U-Bar



205-S/SSS
Flanged Base
Solid Bar



-USS Stainless Steel Model

205-SB ⓘ
Straight Base
Solid Bar



205-SL ⓘ
Left Flanged Base
Solid Bar



205-SR ⓘ
Right Flanged Base
Solid Bar



Technical Information

| Model | Max. Holding Capacity | Clamp Bar Opening (+10°) | Handle Opening (+10°) | Weight | Accessories (Supplied) | |
|----------|-----------------------|--------------------------|-----------------------|-------------------|------------------------|-----------------|
| | | | | | Spindle Assembly | Flanged Washers |
| 205-U | 270 N [60 lbf] | 90° | 80° | 0,03 kg [0.06 lb] | 205208-M | 105106 |
| 205-UB ⓘ | | | | | | |
| 205-UL ⓘ | | | | | | |
| 205-UR ⓘ | 340 N [75 lbf] | 94° | 82° | | 205208-M | -- |
| 205-USS | | | | | | |
| 205-S | | | | | | |
| 205-SB ⓘ | 270 N [60 lbf] | 94° | 82° | 205208-M | -- | |
| 205-SL ⓘ | | | | | | |
| 205-SR ⓘ | | | | | | |
| 205-SSS | 340 N [75 lbf] | | | | 205943-M | |

ⓘ This item is available upon request

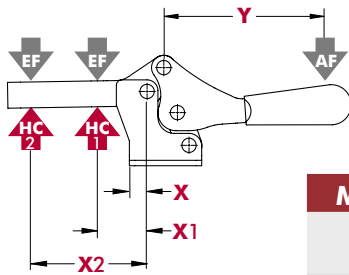

| Model | X | X1 | X2 | Y | ±HC1 | ±HC2 | ±EF(X1):AF | ±EF(X2):AF |
|-------|---------------|--------------|----------------|----------------|-------------------|-------------------|------------|------------|
| U | | [0.43] 11 | | | [60 lbf] 270 N | [50 lbf] 220 N | 9:1 | 5:1 |
| USS | [0.22] 5,6 | | [0.81] 20,5 | [1.31] 33,2 | [75 lbf] 340 N | [65 lbf] 290 N | | |
| S | | -- | | | -- | [60 lbf] 270 N | -- | 4:1 |
| SSS | | | | | | [75 lbf] 340 N | | |

Dimensions shown "mm [inch]" ± HC = Holding Capacity, EF = Exerting Force, AF = Applied Force
See page MC-TEC-4 for additional information.

Dimensions | -U/-UB/-UL-/-UR/-USS/-S/-SB/-SL/-SR/-SSS

205-U
Flanged Base
U-Bar

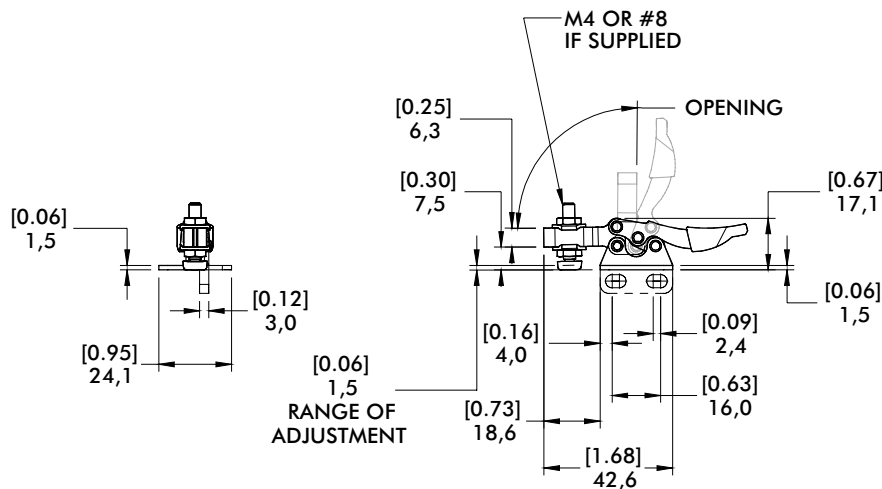
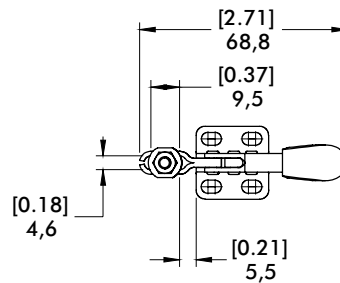

205-S
Flanged Base
Solid Bar

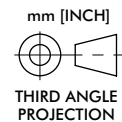
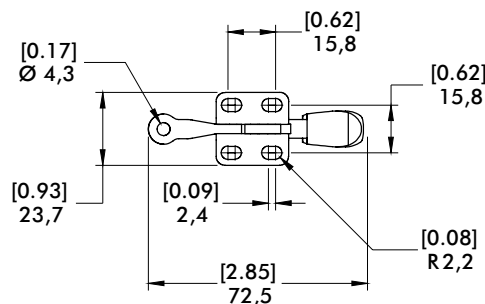

215 SERIES

Horizontal Hold Down Clamps | Product Overview

Features:

- Low profile
- Stainless steel model furnished without plastic grip

Applications:

- Assembly
- Checking fixtures
- Closures
- Woodworking

Also Available:

See page MC-ACC-1 for accessories
Accommodates M6 or 1/4" spindle accessory

215-U/USS Flanged Base U-Bar



-USS Stainless Steel Model

215-UB ⓘ Straight Base U-Bar



215-S Flanged Base Solid Bar



Technical Information

| Model | Max. Holding Capacity | Clamp Bar Opening (+10°) | Handle Opening (+10°) | Weight | Accessories (Supplied) | | |
|----------|-----------------------|--------------------------|-----------------------|-------------------|------------------------|-----------------|---------------|
| | | | | | Spindle Assembly | Flanged Washers | Bolt Retainer |
| 215-U | 890 N [200 lbf] | 87° | 78° | 0,15 kg [0,34 lb] | 202208-M | 215105 | -- |
| 215-USS | 1110 N [250 lbf] | | | | 202943-M | 215905 | |
| 215-UB ⓘ | 890 N [200 lbf] | | | | 202208-M | 215105 | |
| 215-S | | | | | -- | -- | 205105 |

ⓘ This item is available upon request

Holding Capacities

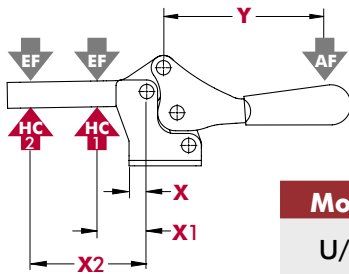

| Model | X | X1 | X2 | Y | ±HC1 | ±HC2 | ±EF(X1):AF | ±EF(X2):AF |
|-------|---------------|----------------|--------------|--------------|---------------------|--------------------|------------|------------|
| U/UB | | [1.00] 25,4 | [2.25] 57 | | [200 lbf] 890 N | [80 lbf] 360 N | 9:1 | 4:1 |
| USS | [0.22] 5,6 | | | [2.72] 69 | [250 lbf] 1110 N | [110 lbf] 490 N | | |
| S | | [1.63] 41,4 | [2.88] 73 | | [200 lbf] 890 N | | 6:1 | |

Dimensions shown "mm [inch]" ± HC = Holding Capacity, EF = Exerting Force, AF = Applied Force
See page MC-TEC-4 for additional information.

215-U
Flanged Base
U-Bar

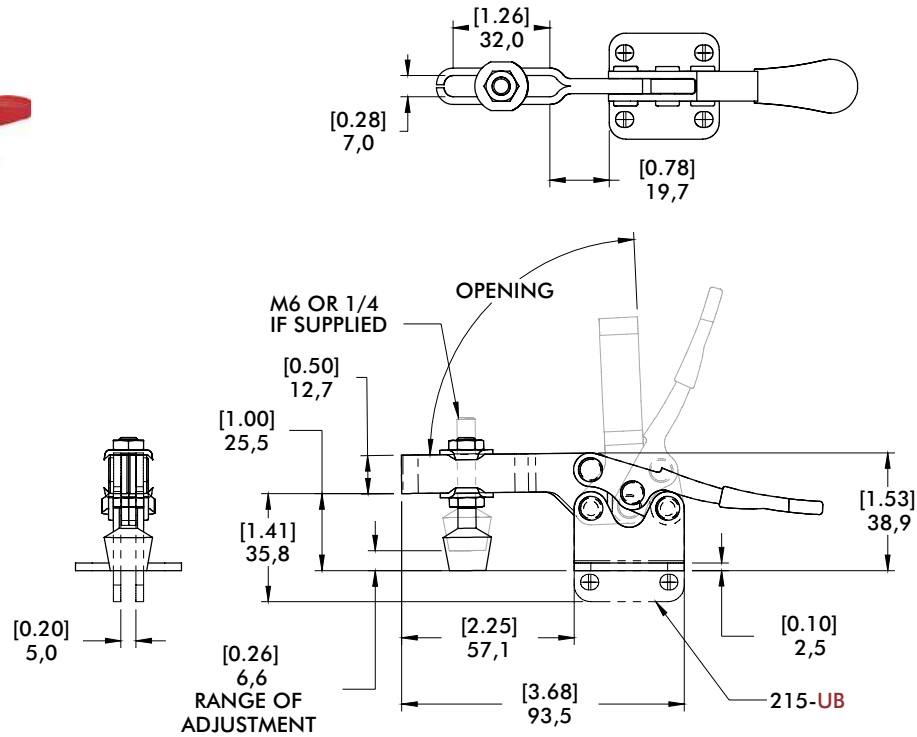

215-S
Flanged Base
Solid Bar

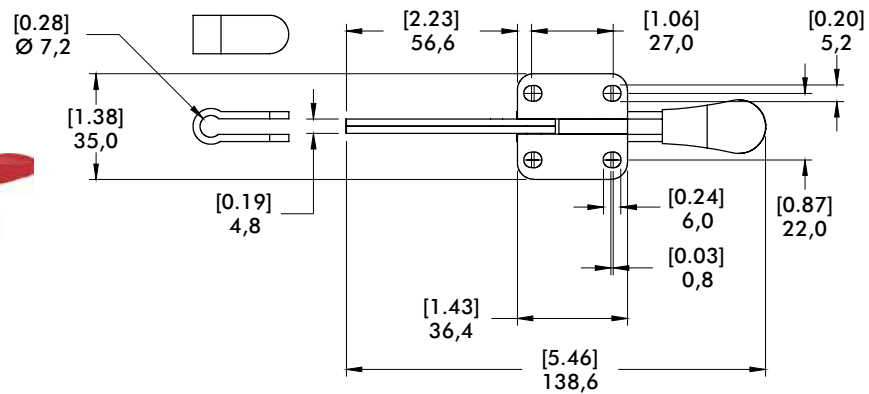

225 SERIES

Horizontal Hold Down Clamps | Product Overview

Features:

- Low profile
- Stainless steel model furnished without plastic grip
- Available DESTACO® Toggle Lock Plus™

Applications:

- Assembly
- Checking fixtures
- Closures
- Woodworking

Also Available:

See page MC-ACC-1 for accessories
Accommodates M8 or 5/16" spindle accessory

Covered under one or more U.S./International Patents

225-U/USS
Flanged Base
U-Bar



225-UR/URSS
Flanged Base
U-Bar
DESTACO®
Toggle Lock
Plus



225-UB/UBSS ⓘ
Straight Base
U Bar



225-UF
Front Mount Base
U-Bar



Technical Information

| Model | Max. Holding Capacity | Clamp Bar Opening (+10°) | Handle Opening (+10°) | Weight | Accessories (Supplied) | |
|------------|-----------------------|--------------------------|-----------------------|-------------------|------------------------|-----------------|
| | | | | | Spindle Assembly | Flanged Washers |
| 225-U | 2220 N [500 lbf] | 92° | 70° | 0,25 kg [0.55 lb] | 225208-M | 507107 |
| 225-USS | 2670 N [600 lbf] | | | | 207943-M | 507907 |
| 225-UR | 2220 N [500 lbf] | | | 0,31 kg [0.69 lb] | 225208-M | 507107 |
| 225-URSS | 2670 N [600 lbf] | | | | 207943-M | 507907 |
| 225-UB ⓘ | 2220 N [500 lbf] | | | 0,25 kg [0.55 lb] | 225208-M | 507107 |
| 225-UBSS ⓘ | 2670 N [600 lbf] | | | | 207943-M | 507907 |
| 225-UF | 2220 N [500 lbf] | | | 0,32 kg [0.70 lb] | 215208-M | 507107 |

ⓘ This item is available upon request

225 SERIES

Horizontal Hold Down Clamps | Holding Capacities

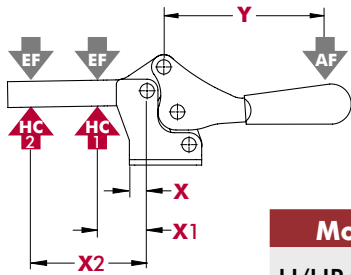

| Model | X | X1 | X2 | Y | ±HC1 | ±HC2 | ±EF(X1):AF | ±EF(X2):AF |
|-------------------|--------|--------|--------|--------|---------------------|---------------------|------------|------------|
| U/UR/UB/UF | [0.12] | [1.25] | [2.50] | [3.56] | [500 lbf] 2220 N | [250 lbf] 1110 N | 12:1 | 5:1 |
| USS/URSS/ UBSS | 3,0 | 31,8 | 63,5 | 90,4 | [600 lbf] 2670 N | [300 lbf] 1340 N | | |

Dimensions shown "mm [inch]" ± HC = Holding Capacity, EF = Exerting Force, AF = Applied Force
See page MC-TEC-4 for additional information.

Dimensions | -U/-USS-/UB-/UBSS

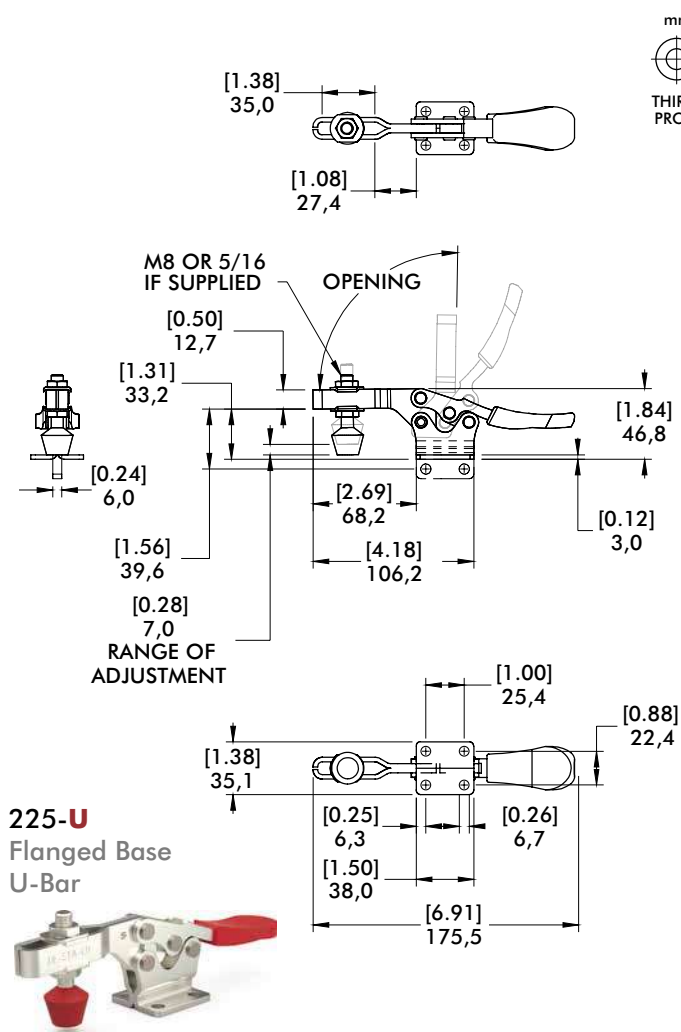

Dimensions | -UR-/URSS

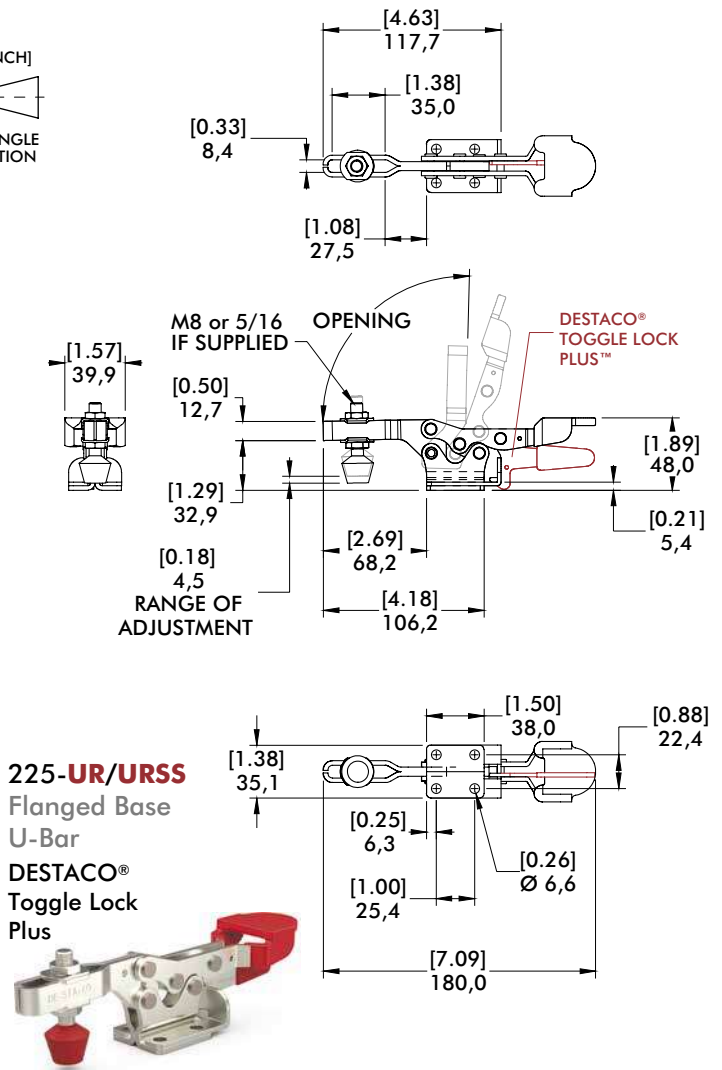

225 SERIES

Horizontal Hold Down Clamps | Dimensions | -UF

225-UF

Front Mount Base
U-Bar

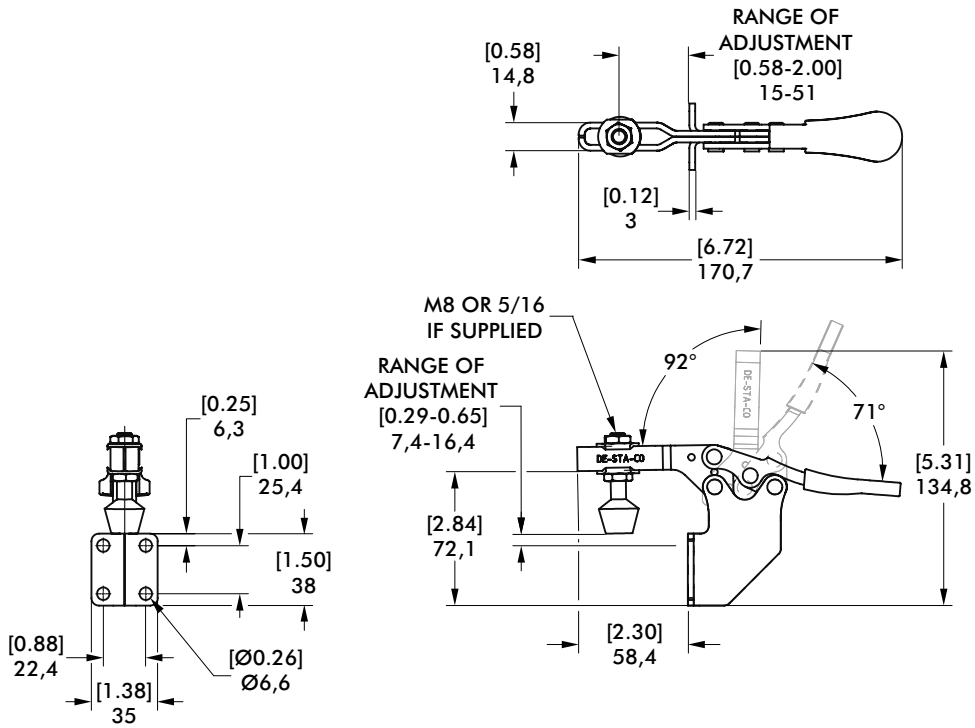
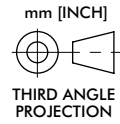

- 5 handle colors - see page MC-PRO-7 for details

235 SERIES

Horizontal Hold Down Clamps | Product Overview

Features:

- Low profile
- Available DESTACO® Toggle Lock Plus™
- Available in stainless steel
- 5 handle colors - see page MC-PRO-7 for details

Applications:

- Assembly
- Checking fixtures
- Welding
- Closures
- Woodworking

Also Available:

See page MC-ACC-1 for accessories

Accommodates M10 or 3/8" spindle accessory

Covered under one or more U.S./International Patents

235-U/USS Flanged Base U-Bar



-USS Stainless Steel Model



235-UR/URSS Flanged Base U-Bar



-URSS Stainless Steel Model

DESTACO® Toggle Lock Plus



235-UB ⓘ Straight Base U Bar



235-UF Front Mount Base U-Bar



Color Handles

Available on models in this series that use standard red handles.* Add -Y, -G, -B, -K to end of model number.

*Excludes Toggle Lock Plus levers or dipped handles.



Technical Information

| Model | Max. Holding Capacity | Clamp Bar Opening (+10°) | Handle Opening (+10°) | Weight | Accessories (Supplied) | |
|----------|-----------------------|--------------------------|-----------------------|-------------------|------------------------|-----------------|
| | | | | | Spindle Assembly | Flanged Washers |
| 235-U | 3340 N [750 lbf] | 92° | 70° | 0,67 kg [1.47 lb] | 240208-M | 235106 |
| 235-USS | 3780 N [850 lbf] | | | | 237943-M | 235906 |
| 235-UR | 3340 N [750 lbf] | | | 240208-M | 235106 | |
| 235-URSS | 3780 N [850 lbf] | | | 237943-M | 235906 | |
| 235-UB ⓘ | 3340 N [750 lbf] | | | 0,67 kg [1.47 lb] | 240208-M | 235106 |
| 235-UF | | | | 0,92 kg [2.03 lb] | 2007208-M | 507107 |

ⓘ This item is available upon request

Holding Capacities

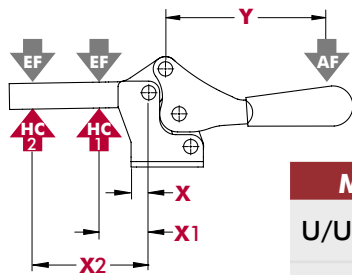

| Model | X | X1 | X2 | Y | ±HC1 | ±HC2 | ±EF(X1):AF | ±EF(X2):AF |
|------------|--------|--------|--------|--------|---------------------|---------------------|------------|------------|
| U/UR/UB/UF | [0.25] | [1.75] | [4.13] | [5.75] | [750 lbf] 3340 N | [300 lbf] 1330 N | 9:1 | 5:1 |
| USS/URSS | 6,4 | 44,5 | 105 | 146 | [850 lbf] 3780 N | [360 lbf] 1600 N | | |

Dimensions shown "mm [inch]" ± HC = Holding Capacity, EF = Exerting Force, AF = Applied Force
See page MC-TEC-4 for additional information.

235 SERIES

Horizontal Hold Down Clamps | Dimensions | -U/-USS/-UR/-URSS/-UB

235-U Flanged Base U-Bar

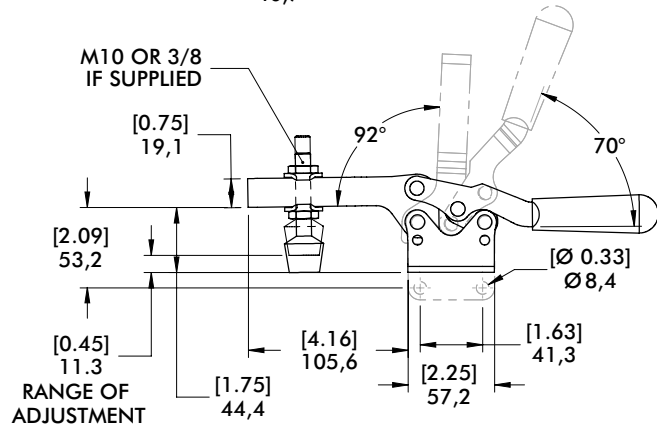
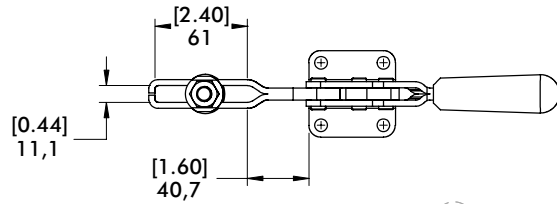
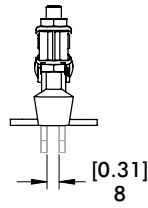

Dimensions | -UR

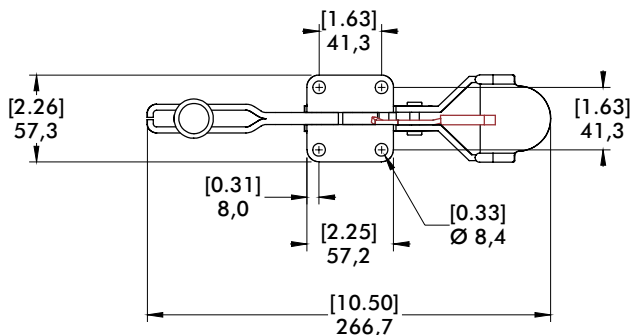
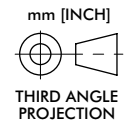
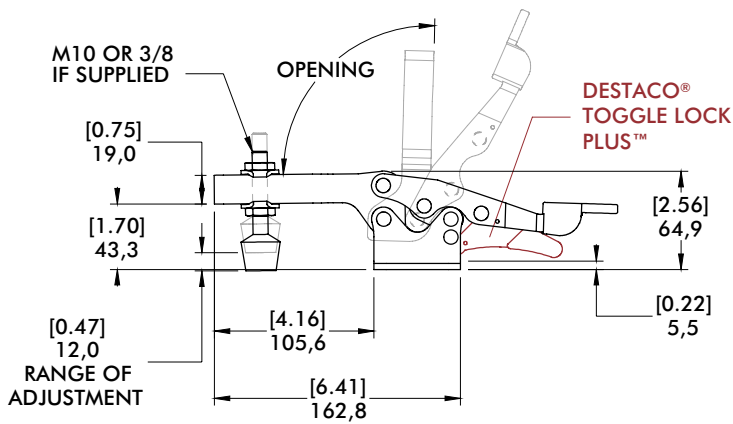
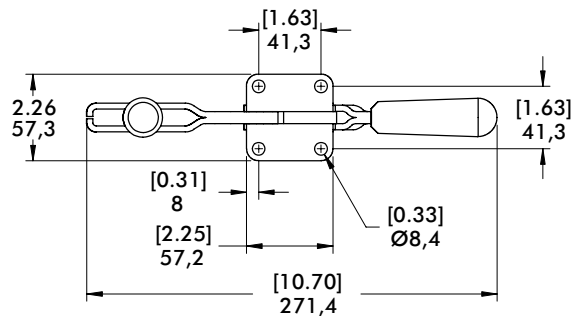
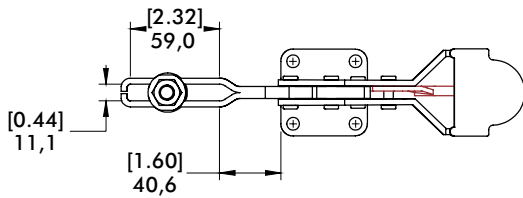

235-UR Flanged Base U-Bar DESTACO® Toggle Lock Plus™



235 SERIES

Horizontal Hold Down Clamps | Dimensions | -UF

235-UF Front Mount Base U-Bar



mm [INCH]
THIRD ANGLE PROJECTION

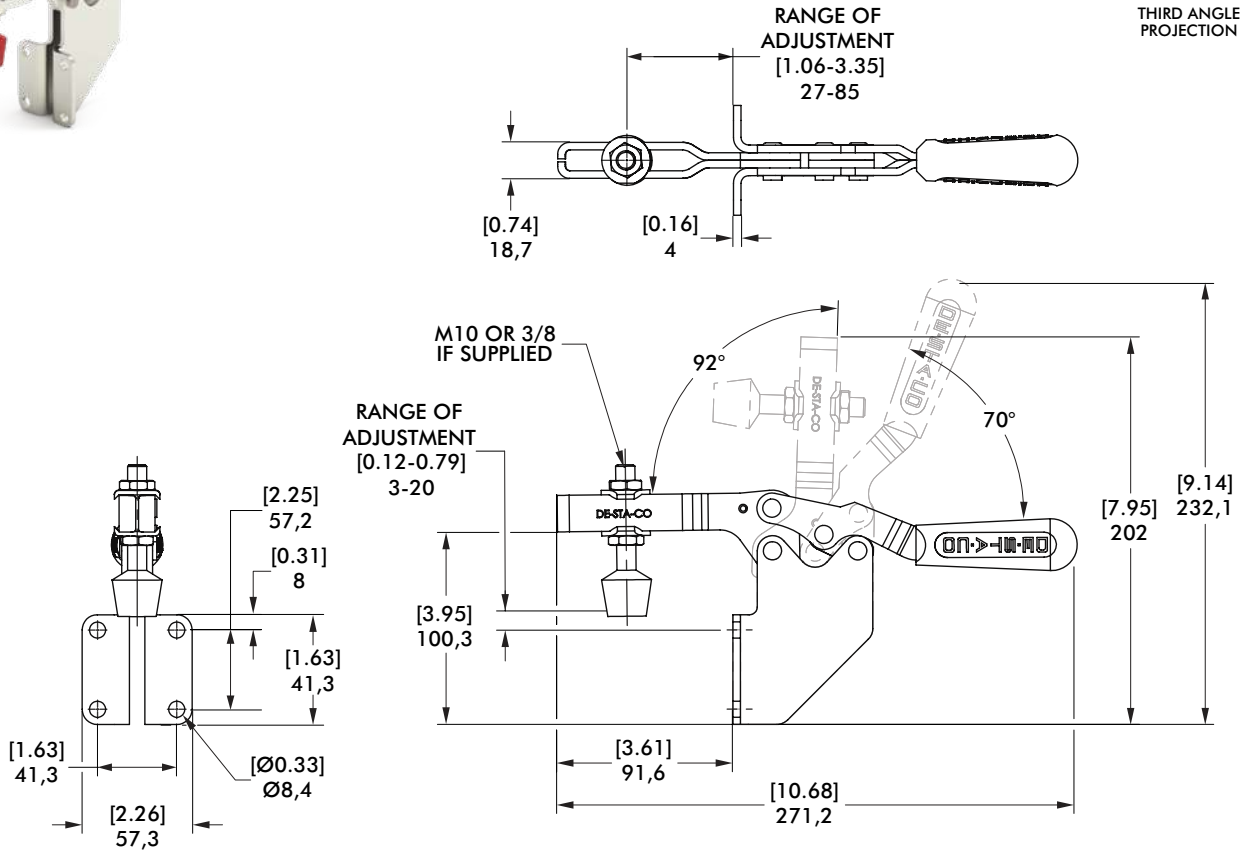

305, 307, 309 SERIES

Horizontal Hold Down Clamps | Product Overview

Features:

- Compact design suitable for use in confined spaces
- Available DESTACO® Toggle Lock Plus™
- Stainless steel models available

Applications:

- Assembly & Test
- Light Machining
- Closures
- Woodworking

Also Available:

See page MC-ACC-1 for accessories

305-U/USS
Flanged Base
U-Bar



-USS Stainless
Steel Model



305-UR/URSS
Flanged Base
U-Bar



-URSS Stainless
Steel Model

DESTACO®
Toggle Lock
Plus™



307-U/USS
Flanged Base
U-Bar



-USS Stainless
Steel Model



307-UR/URSS
Flanged Base
U-Bar



-URSS Stainless
Steel Model

DESTACO®
Toggle Lock
Plus™



309-U/USS
Flanged Base
U-Bar



-USS Stainless
Steel Model



309-UR①
Flanged Base
U-Bar

DESTACO®
Toggle Lock
Plus™



Technical Information

| Model | Max. Holding Capacity | Clamp Bar Opening (+10°) | Handle Opening (+10°) | Weight | Accessories (Supplied) | |
|----------|-----------------------|--------------------------|-----------------------|-------------------|------------------------|-----------------|
| | | | | | Spindle Assembly | Flanged Washers |
| 305-U | 670 N [150 lbf] | 90° | 170° | 0,06 kg [0.13 lb] | 305208-M | 102111 |
| 305-USS | 900 N [200 lbf] | | | | 305908-M | 102911 |
| 305-UR | 670 N [150 lbf] | | | | 305208-M | 102111 |
| 305-URSS | 900 N [200 lbf] | | | | 305908-M | 102911 |
| 307-U | 1560 N [350 lbf] | 92° | 173° | 0,24 kg [0.54 lb] | 307208-M | 507107 |
| 307-USS | | | | | 442943 | 507907 |
| 307-UR | | | | | 307208-M | 507107 |
| 307-URSS | | | | | 442943 | 507907 |
| 309-U | 3340 N [750 lbf] | 90° | 168° | 1,30 kg [0.59 lb] | 309208 | 235106 |
| 309-USS | | | | | 237943 | 235906 |
| 309-UR① | | | | | 309208 | 235106 |

① This item is available upon request

305, 307, 309 SERIES

Horizontal Hold Down Clamps | Holding Capacities

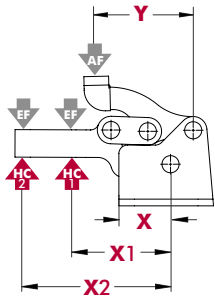

| Model | X | X1 | X2 | Y | ±HC1 | ±HC2 | ±EF(X1):AF | ±EF(X2):AF |
|-----------------------|--------|--------|--------|--------|---------------------|---------------------|------------|------------|
| 305-U/UR | [0.58] | [1.38] | [1.88] | [1.14] | [150 lbf] 670 N | [110 lbf] 490 N | 3:1 | 2:1 |
| 305-USS/ 305-URSS | 14,6 | 35 | 47,7 | 29 | [200 lbf] 900 N | [150 lbf] 670 N | | |
| 307-U/UR/ USS/URSS | [0.94] | [1.88] | [2.50] | [1.77] | [350 lbf] 1560 N | [260 lbf] 1160 N | 4:1 | |
| 309- U/UR/USS | [1.34] | [2.50] | [3.50] | [2.70] | [750 lbf] 3340 N | [530 lbf] 2360 N | | |

Dimensions shown "mm [inch]" ± HC = Holding Capacity, EF = Exerting Force, AF = Applied Force
See page MC-TEC-4 for additional information.

Dimensions | -U/-USS/-UR/-URSS

305-U
Flanged Base
U-Bar

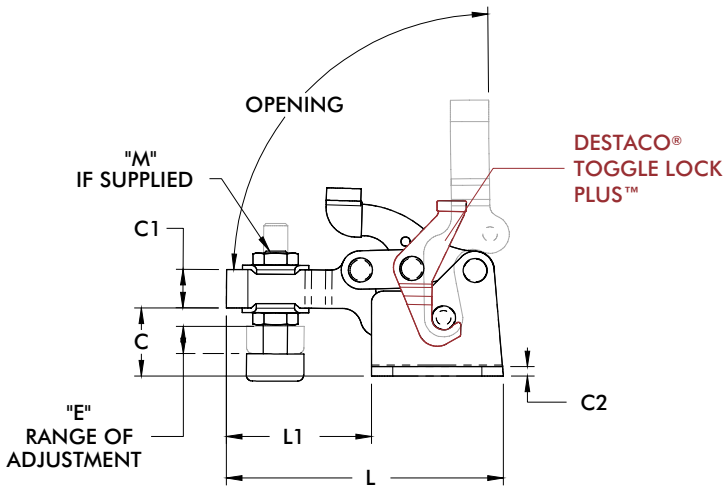
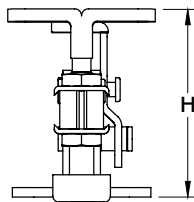
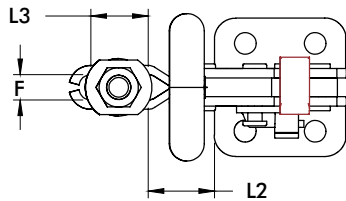

307-UR
Flanged Base
U-Bar
DESTACO®
Toggle Lock
Plus™

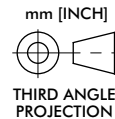
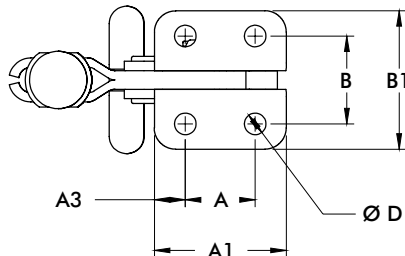

| Model | A | A1 | A3 | B | B1 | C | C1 | C2 | D | E | F | H | L | L1 | L2 | L3 | M |
|----------|----------------|-----------------|----------------|----------------|----------------|----------------|----------------|---------------|---------------|----------------|----------------|----------------|-----------------|----------------|----------------|----------------|-----------------|
| 305-U/UR | [0.53] 13,5 | [1.035] 26,3 | [0.25] 6,4 | [0.62] 16,0 | [1.02] 25,9 | [0.48] 12,2 | [0.31] 7,9 | [0.08] 2,0 | [0.18] 4,6 | [0.31] 8 | [0.21] 5,3 | [1.43] 36,3 | [2.21] 56,1 | [1.19] 30,2 | [0.51] 13,0 | [0.50] 12,7 | [#10] M5 |
| 307-U/UR | [0.91] 23,1 | [1.72] 43,7 | [0.40] 10,2 | [1.14] 29,0 | [1.80] 45,7 | [0.89] 22,6 | [0.50] 12,7 | [0.12] 3,0 | [0.28] 7,1 | [0.37] 9,5 | [0.33] 8,4 | [2.36] 59,9 | [3.61] 91,7 | [1.89] 48,0 | [0.86] 21,8 | [0.75] 19,1 | [5/16] M8 |
| 309-U/UR | [1.38] 35,1 | [2.52] 64,0 | [0.58] 14,7 | [1.50] 38,1 | [2.47] 62,7 | [1.31] 33,3 | [0.75] 19,1 | [0.12] 3,0 | [0.33] 8,4 | [0.72] 18,5 | [0.44] 10,4 | [3.53] 89,7 | [5.19] 131,8 | [2.68] 68,1 | [1.28] 32,5 | [1.06] 26,9 | [3/8-16] M10 |

206 SERIES

Horizontal Hold Down Clamps | Product Overview

Features:

- All stainless steel construction
- Offers good bar clearance under clamping bar while maintaining low profile

Applications:

- Assembly
- Chemical processing
- Closures
- Light duty clamping

Also Available:

See page MC-ACC-1 for accessories
Accommodates M4 or #8 spindle accessory

206-SS

Flanged Base
Low U-Bar
Stainless Steel



206-HSS

Flanged Base
High U-Bar
Stainless Steel



Technical Information

| Model | Max. Holding Capacity | Clamp Bar Opening (+10°) | Handle Opening (+10°) | Weight | Accessories (Supplied) | |
|---------|-----------------------|--------------------------|-----------------------|-------------------|------------------------|-----------------|
| | | | | | Spindle Assembly | Flanged Washers |
| 206-SS | 440 N [100 lbf] | 90° | 90° | 0,03 kg [0.07 lb] | 205943-M | 105906 |
| 206-HSS | | 85°* | 85°* | | | |

*with spindle installed

Model 206-HSS shown securing a platen on a prototyping machine.

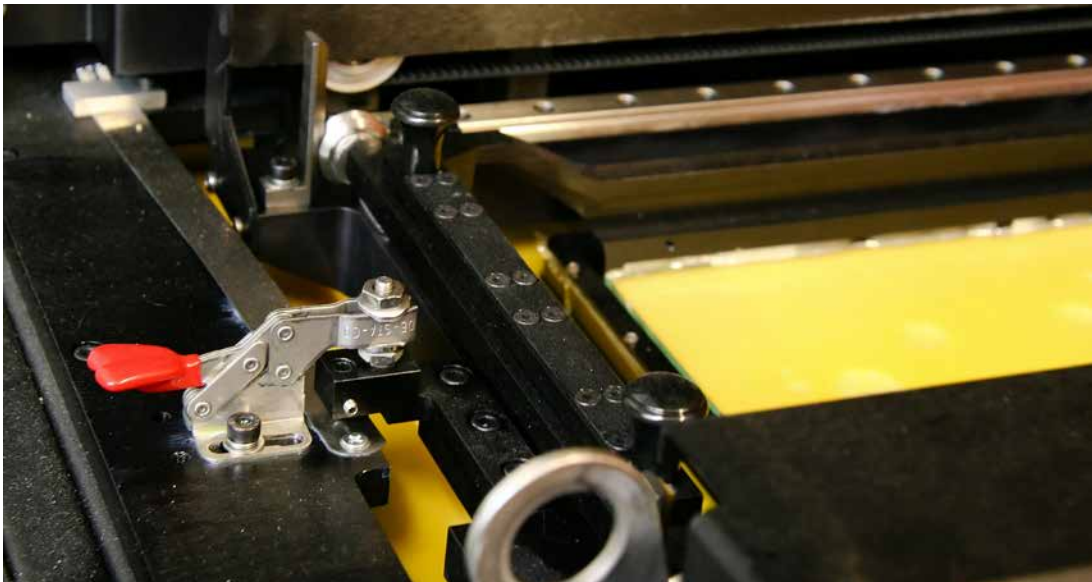

206 SERIES

Horizontal Hold Down Clamps | Holding Capacities

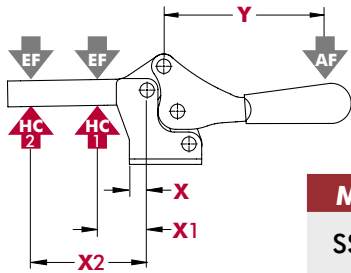

| Model | X | X1 | X2 | Y | ±HC1 | ±HC2 | ±EF(X1):AF | ±EF(X2):AF |
|--------|-------------|--------------|--------------|--------------|--------------------|-------------------|------------|------------|
| SS/HSS | [0.20] 5 | [0.43] 11 | [1.06] 27 | [1.14] 29 | [100 lbf] 440 N | [50 lbf] 220 N | 5:1 | 3:1 |

Dimensions shown "mm [inch]" ± HC = Holding Capacity, EF = Exerting Force, AF = Applied Force
See page MC-TEC-4 for additional information.

Dimensions | -SS/-HSS

206-SS

Flanged Base
Low U-Bar
Stainless Steel

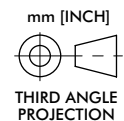
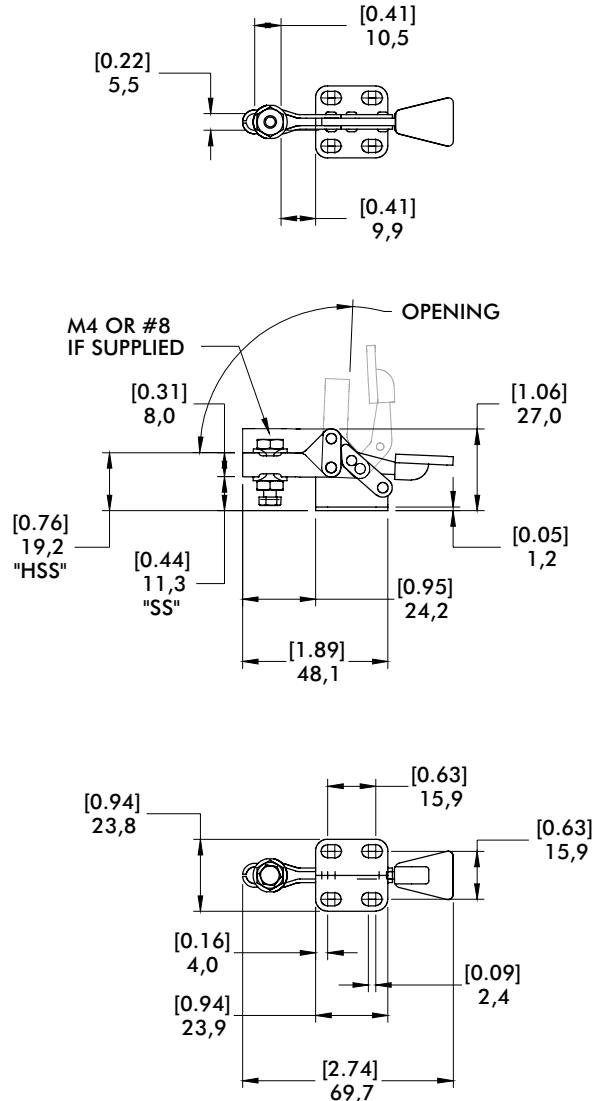

5305, 5310 SERIES

Heavy Duty Horizontal Hold Down Clamps | Product Overview

Features:

- Solid clamping arm may be modified to suit requirements
- Hardened steel pivot pins and bushings provide long life
- Black oxide finish
- DESTACO® Toggle Lock Plus™ versions available†
- 5 handle colors - see page MC-PRO-7 for details

Applications:

- Welding fixtures
- Assembly fixtures
- Light machining



5305/5310
Flanged Base



5305-B/5310-B
Solid Base



5305-R/5310-R
Flanged Base
DESTACO®
Toggle Lock
Plus™



5305-BR①/5310-BR①
Solid Base
DESTACO®
Toggle Lock
Plus™



Technical Information

| Model | Max. Holding Capacity | Clamp Bar Opening (+10°) | Handle Opening (+10°) | Weight |
|----------|-----------------------|--------------------------|-----------------------|-------------------|
| 5305 | [600 lbf] 2670 N | 90° | 69° | [1.08lbs] 0,49 kg |
| 5305-B | | | | [0.82lbs] 0,37 kg |
| 5305-R | | | | [1.09lbs] 0,49 kg |
| 5305-BR① | | | | [0.83lbs] 0,37 kg |
| 5310 | [1300 lbf] 5780 N | 90° | 69° | [2.84lbs] 1,29 kg |
| 5310-B | | | | [2.24lbs] 1,02 kg |
| 5310-R | | | | [2.87lbs] 1,30 kg |
| 5310-BR① | | | | [2.27lbs] 1,03 kg |

① This item is available upon request.

† Toggle Lock Plus™ locks the handle in the closed position only.

Color Handles

Available on models in this series that use standard red handles.* Add -Y, -G, -B, -K to end of model number.

*Excludes Toggle Lock Plus levers or dipped handles.



Holding Capacities

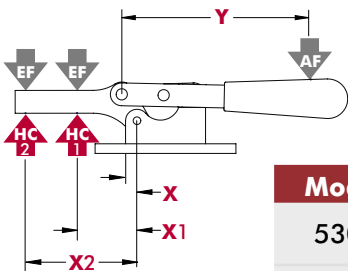

| Model | X | X1 | X2 | Y | ±HC1 | ±HC2 | ±EF(X1):AF | ±EF(X2):AF |
|-------|---------------|--------------|--------------|---------------|----------------------|---------------------|------------|------------|
| 5305 | [0.25] 6,3 | [1.57] 40 | [2.75] 70 | [4.92] 125 | [600 lbf] 2670 N | [340 lbf] 1500 N | 10:1 | 5:1 |
| 5310 | [0.38] 9,5 | [1.97] 50 | [3.66] 93 | [6.10] 155 | [1300 lbf] 5780 N | [675 lbf] 3000 N | 10:1 | 8:1 |

Dimensions shown "mm [inch]" ± HC = Holding Capacity, EF = Exerting Force, AF = Applied Force
See page MC-TEC-4 for additional information.

5305, 5310 SERIES

Heavy Duty Horizontal Hold Down Clamps | Dimensions

5305/5310
Flanged Base

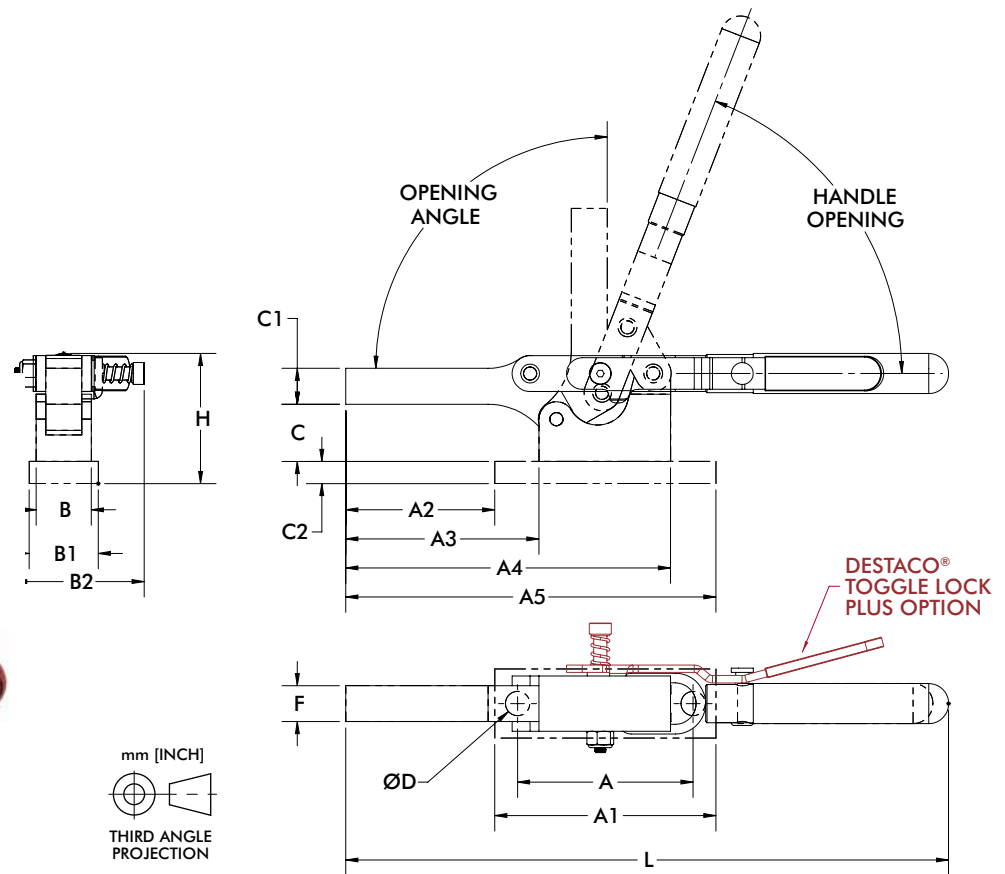

| Model | A | A1 | A2 | A3 | A4 | A5 | B | B1 | B2 | C | C1 | C2 | D | F | H | L |
|--------|----------------|-----------------|----------------|----------------|-----------------|-----------------|----------------|----------------|----------------|----------------|----------------|---------------|----------------|----------------|----------------|------------------|
| 5305 | [2.50] 63,5 | [3.15] 80,0 | [2.12] 53,8 | [2.75] 69,9 | [4.63] 117,6 | [5.27] 133,9 | [0.79] 20,1 | [0.98] 24,9 | -- | [0.81] 20,6 | [0.51] 13,0 | [0.31] 7,9 | [0.35] 8,9 | [0.51] 13,0 | [1.51] 38,4 | [8.36] 212,4 |
| 5305-R | | | | | | | | | [1.84] 46,7 | | | | | | | |
| 5310 | [3.63] 92,2 | [4.63] 117,6 | [2.63] 66,8 | [3.63] 92,2 | [6.25] 158,8 | [7.25] 184,2 | [1.13] 28,7 | [1.50] 38,1 | -- | [1.00] 25,4 | [0.75] 19,1 | [0.31] 7,9 | [0.41] 10,4 | [0.79] 20,1 | [2.00] 50,8 | [11.13] 282,6 |
| 5310-R | | | | | | | | | [2.31] 58,7 | | | | | | | [11.02] 279,8 |

| Model | A3 | A4 | B2 | C | C1 | F | H | L |
|----------------------|----------------|-----------------|----------------|----------------|----------------|----------------|----------------|------------------|
| 5305-B | [2.75] 69,9 | [4.63] 117,6 | -- | [0.81] 20,6 | [0.51] 13,0 | [0.51] 13,0 | [1.51] 38,4 | [8.36] 212,4 |
| 5305-BR ^① | | | [1.84] 46,7 | | | | | |
| 5310-B | [3.63] 92,2 | [6.25] 158,8 | -- | [1.00] 25,4 | [0.75] 19,1 | [0.79] 20,1 | [2.35] 59,6 | [11.13] 282,6 |
| 5310-BR ^① | | | [2.31] 58,7 | | | | | [11.02] 279,8 |

^① This item is available upon request

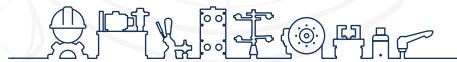

inf @ /CESEHSA.com.mx

