

Grippers, Rotates, Slides (GR)

01/30/2025



info@cesehsa.com.mx

cesehsa.com.mx



Grippers, Rotates, Slides (GR)

01/30/2025

This catalog is a custom document and the products included is based on your unique selection from portions of complete catalogs that already exist. Please refer to our full catalogs for more information on products not included in this customized document.

Table of Contents

Product Overview	GR-PRO-1
Technical Comparison Chart (GR)	GR-TCH-1
OEM Machine Builder Products	GR-OEM-1
Electric Parallel Grippers (2-Jaw)	GR-EPG-1
Precision Parallel Grippers (2-Jaw)	GR-PRC-1
General Industrial Grippers (2-Jaw)	GR-GEN-1
Heavy Duty Parallel Grippers (2-Jaw)	GR-HDP-1
3-Jaw Parallel Grippers	GR-3JP-1
Angular Grippers	GR-ANG-1
Speciality Grippers	GR-SPC-1
Rotary Actuators	GR-ROT-1
Linear Slides	GR-LIN-1
Feed Escapements	GR-ESC-1

Grippers, Rotates, Slides (GR)

01/30/2025

Table of Contents (continued)

GRIPPERS/SLIDES/ROTARIES

Table of Contents

Introduction:

North American Xpress Program	GR-PRO-2
European Xpress Program	GR-PRO-3
Clean Room Solutions.....	GR-PRO-6
Robotic Tooling Solutions	GR-PRO-7
Modular Mounting Solutions/DirectConnect™	GR-PRO-11
Product Sizing and Application Charts	GR-TCH-1



Electric Grippers GR-EPG



Precision Grippers GR-PRC



General Industrial Grippers .. GR-GEN



Heavy Duty GrippersGR-HDP



OEM Machine Builder.....GR-OEM



3-Jaw Parallel Grippers GR-3JP



Angular Grippers..... GR-ANG



Specialty Grippers GR-SPC



Rotary Actuators GR-ROT



Linear Slides..... GR-LIN



Feed Escapements..... GR-ESC

NORTH AMERICAN XPRESS PROGRAM

A Full Line of Automation Products to Meet Your Application Needs Quickly













ON OUR MOST POPULAR PRODUCTS

To choose the best and most cost-effective automation solution for your application please contact your DESTACO sales representative or DESTACO customer service.

Product listed below are for North American Market only.

Parallel Grippers

		 SIZE	 STROKE [mm]	 FORCE [N]
	HEAVY DUTY RDH/RTH Series 2 & 3 Jaw Impact Resistant Shielded Gripper	1, 2, 3, 4, 5 -L Stroke option	4.0-26	125-675
	HEAVY DUTY RP Series Rugged Impact Resistant Gripper	5, 10, 11, 12, 15	4.0-12.7	156-311
	RPL/RPLC Series Zero Side Play, High Repeatability Gripper	1, 2, 3, 4 (C)=Clean Room Version	6.4-25.4	116-160
	RPM/RPMC Series Low Friction Micro Gripper	1, 2, 3, (C)=Clean Room Version	4.1-6.3	36
	DPG Series Modular Multi-Part Sensing Gripper	10M-2	12.7	222
	HEAVY DUTY DPW Series Wide Parts/ Long Finger Gripper	250, 375, 500	19.05-63.5	222-800
	HEAVY DUTY RPW Series Wide Parts/ Long Finger Gripper	625	50.8-88.9	1068

Angular Grippers

		 SIZE	 ANGLE	 FORCE [N]
	RA Series Low Cost Small Size Angular Gripper	RA-5	15° (per finger)	89

Rotary Actuators

		 SIZE	 ANGLE	 PAYLOAD [Kg]
	RR Series High Torque Compact Rotary Actuators	18, 28, 36	0-180°	0.45-3.6

EUROPEAN XPRESS PROGRAM

A Full Line of Automation Products to Meet Your Application Needs Quickly



ON OUR MOST POPULAR PRODUCTS

To choose the best and most cost-effective automation solution for your application please contact your DESTACO sales representative or DESTACO customer service.

Product listed below are for European Market only.



SIZE















STROKE [mm]



FORCE [N]

2-Jaw Parallel Grippers

		SIZE	STROKE [mm]	FORCE [N]
	HEAVY DUTY RDH Series Impact Resistant Shielded Gripper	All Sizes	4-70	361-28002
	2P Series Precision Cylindrical Gripper	All Sizes	10-30	109-3043
	REP-2 Series Cylindrical Shielded Gripper	All Sizes	10-30	480-3351
	DGC Series Precision Long Stroke Gripper	All Sizes	20-60	474-2318
	DPG Series Modular Gripper	All Sizes	6.4-25.4	222
	DPW Series Wide Parts/ Long Finger Gripper	All Sizes	19.1-63.5	222-800
	HEAVY DUTY RPW Series Wide Parts/ Long Finger Gripper	625, 750	19.1-114.3	222-2091
	HEAVY DUTY RP Series Rugged Impact Resistant Gripper	All Sizes	4.0-50.8	40-3336
	DPL Series Long Stroke, Low Profile Gripper	All Sizes	40-140	811-2035
	CP Series Compact Gripper	All Sizes	4-32	10-2749
	RPL/RPLC Series Zero Side Play, High Repeatability Gripper	All Sizes (C)=Clean Room	6.4-25.4	116-160
	RPM/RPMC Series Low Friction Micro Gripper	All Sizes (C)=Clean Room	3.2-6.3	36
	RDE Series Water Immersion Gripper	Contact DESTACO for More Information		

EUROPEAN XPRESS PROGRAM

A Full Line of Automation Products to Meet Your Application Needs Quickly











ON OUR MOST POPULAR PRODUCTS







To choose the best and most cost-effective automation solution for your application please contact your DESTACO sales representative or DESTACO customer service.

Product listed below are for European Market only.

3-Jaw Parallel Grippers

		 SIZE	 STROKE [mm]	 FORCE [N]	
    	HEAVY DUTY	RTH Series Impact Resistant Shielded Gripper	All Sizes	4-20	579-4562
		3P Series Precision Cylindrical Gripper	All Sizes	10-30	107-2030
		REP-3 Series Cylindrical Shielded Gripper	All Sizes	10-30	469-3268
		PPC Series Thru-Hole Gripper	All Sizes	10-30	896-4332
		RTE Series Water Immersion Gripper	Contact DESTACO for More Information		

Angular Grippers

		 SIZE	 ANGLE	 FORCE [N]	
   		RUA Series Cylindrical Gripper	All Sizes	15.9-19.1° (per finger)	313-3941
		DCT-CT Series 180° Jaw Opening Gripper	All Sizes	90° (per finger)	32-893
		RA Series Compact Gripper	RA-6	15° (per finger)	71-801
		FUA Series Food Gripper	All Sizes	35° (per finger)	9-32

EUROPEAN XPRESS PROGRAM

A Full Line of Automation Products to Meet Your Application Needs Quickly



ON OUR MOST POPULAR PRODUCTS

To choose the best and most cost-effective automation solution for your application please contact your DESTACO sales representative or DESTACO customer service.

Product listed below are for European Market only.

Rotary Actuators



SIZE



ANGLE



PAYLOAD [Kg]



RR Series Light-Duty
High Torque Compact
Rotary Actuators

All Sizes

0-180°

0.45-1.3



RR Series Heavy-Duty
High Torque Compact
Rotary Actuators

All Sizes

0-180°

3.6-91

Feed Escapements



SIZE

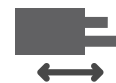

STROKE [mm]



PARTS ESCAPED



RFE Series
2-Finger Actuation

All Sizes

16-32

85-150
(per minute)

Tool Changers and Compliance



SIZE



PORTS



PAYLOAD [Kg]



RQC/RTP Series
Heavy-Duty
Tool Changer

All Sizes

19 pin
Electrical and
6 Pneumatic
Ports

90-550



QC/TP Series
Tool Changer

All Sizes

12-15 pin
Electrical and
4 Pneumatic
Ports

30-150



CH Series
Horizontal Compliance

All Sizes

N/A

2-40



AU Series
Resettable Emergency
Stop Module

Contact DESTACO for More Information

CLEAN ROOM RATED SOLUTIONS

Grippers/Slides/Rotaries | Product Overview

DESTACO's Clean Room Rated Solutions are geared toward laboratory, semiconductor, medical, and food handling type environments. Many of our pneumatic products include a scavenge or purge port. These extra ports create internal vacuum or pressure to control contaminants escaping into the environment or prevent de-greaser or other chemicals penetrating our product.

Solutions include:

- Diverse line-up of products for class 10/100 cleanroom environments
- Manufactured with corrosion-resistant materials for use with de-ionized water
- Customized solutions available with food and medical grade lubricants, stainless steel, and nickel-plated materials to meet your application requirements.

Electric Parallel Grippers			
Rating	RPE-100	DPE-200	DPE-400
ISO 4 (Class 10)	☉☉		
ISO 5 (Class 100)	☉		☉
ISO 6 (Class 1,000)	☉	☉	☉
ISO 7 (Class 10,000)	☉	☉	☉
ISO 8 (Class 100,000)	☉	☉	☉

Pneumatic 2-Jaw and 3-Jaw Grippers									
Rating	RPMC	RPLC	DPDS	DPDL	DPG	DPP	RDH	RTH	DCT
ISO 4 (Class 10)	☉☉	☉☉	☉☉						
ISO 5 (Class 100)	☉☉☉	☉☉☉	☉☉☉	☉☉☉	☉		☉☉	☉☉	☉
ISO 6 (Class 1,000)	☉☉☉	☉☉☉	☉	☉	☉		☉	☉	☉
ISO 7 (Class 10,000)	☉	☉	☉	☉	☉	☉	☉	☉	☉
ISO 8 (Class 100,000)	☉	☉	☉	☉	☉	☉	☉	☉	☉

Linear Slides			
Rating	DLB	DLT	DLM
ISO 4 (Class 10)			
ISO 5 (Class 100)			
ISO 6 (Class 1,000)	☉	☉	☉
ISO 7 (Class 10,000)	☉	☉	☉
ISO 8 (Class 100,000)	☉	☉	☉

Rotaries	
Rating	RR
ISO 4 (Class 10)	
ISO 5 (Class 100)	
ISO 6 (Class 1,000)	
ISO 7 (Class 10,000)	
ISO 8 (Class 100,000)	☉

- ☉ Standard Clean Room
- ☉☉ With use of Scavenge Port

Note: All products tested using Krytox™ Grease. Please contact factory for individual test results and additional clean room requirements.

ROBOTIC TOOLING SOLUTIONS

CLICK OR SCAN
To view full catalog pages
on these product

Automatic Tool Changers | Features and Benefits

Automatic Tool Changers

Robotic Applications:

Perfect for those flexible/multiple tooling applications utilizing one Robot. This product was designed with exceptional repeatability, high rigidity & load capacity to make it ideal for any robotic application.

Automation Applications:

End effector tooling and interchangeable fixturing can be changed quickly and easily to accommodate many different styles of parts on the same assembly machine or machining center.

Highly Configurable, Modular Design (RQC/RTP):

The Modular RQC series easily accommodates up to (4) optional modular interfaces, offering a high level of flexibility.

Mounting Information

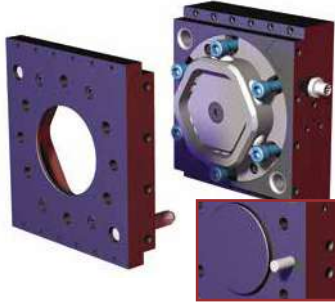

RQC Robot Plate Adaptor

Counterbored holes for mounting with a dowel pin hole, a raised boss for location and a ISO9409-1 mounting pattern.

Back Side of RQC

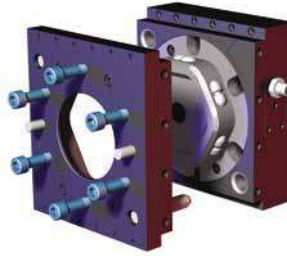

RTP Tool Plate Adaptor

Tapped holes, two dowel pin holes for accurate location of payload and a ISO9409-1 mounting pattern.



QC Robot Plate Adaptor

has counterbored holes for mounting and two dowel pins for hole location (size 30 has pilot boss).



TP Tool Plate Adaptor

has counterbored holes for mounting and two dowel pins for hole location (size 30 has pilot boss).



RHC Robot Plate Adaptor

mounts with screws from behind or through the front and locates with dowel pins for accuracy.



RHC Tool Plate Adaptor

mounts payload with screws from behind or through the front and locates with dowel pins for accuracy. Protect cone surfaces from debris to insure proper positioning.



Compliance Device | Features and Benefits

Flexibility of the Tool:

Cylindrical Horizontal compliance devices are used for inserting components that may be misaligned with the tool. They allow a horizontal displacement that compensates for part placing inaccuracies.

For Precision Applications:

High quality components allows for centering repeatability from 0.02mm and angular repeatability from $\pm 10^\circ$.

Harsh Environments:

Enclosed design allows them to be used in harsh environments.

Spring Assist:

Optional spring assist allows for use in single acting mode.



Mounting Information



CH Horizontal Compliance

The compliance is located using a pilot boss and a dowel pin and assembled using 4 or 6 through body screws.



Tool Mounting

Tooling is located using a centering and a dowel pin and assembled using 4 screws.



See pages 2-5 for product availability in your region.



CLICK OR SCAN

To view full catalog pages on this product

RQC/RTP SERIES

Automatic Tool Changers | Technical Information



See pages 2-5 for product availability in your region.

RQC-200/RTP-200

Combined Weight: 3 Kg [6.7 lb]
Max. Payload: 90 Kg [200 lb]
Max. Moment: 810 Nm [7200 in-lb]

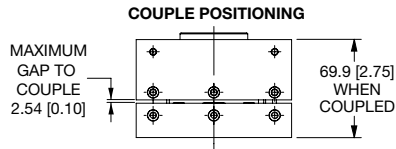

RQC-200 Robot Plate
RTP-200 Tool Plate

RQC-400/RTP-400

Combined Weight: 4.7 Kg [10.4 lb]
Max. Payload: 180 Kg [400 lb]
Max. Moment: 1580 Nm [14000 in-lb]

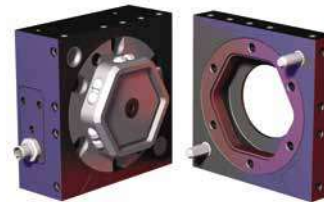
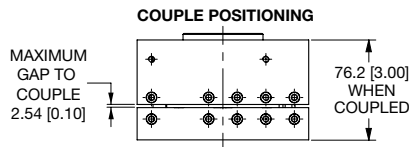

RQC-400 Robot Plate
RTP-400 Tool Plate

RQC-800/RTP-800

Combined Weight: 7.1 Kg [15.8 lb]
Max. Payload: 360 Kg [800 lb]
Max. Moment: 2490 Nm [22000 in-lb]

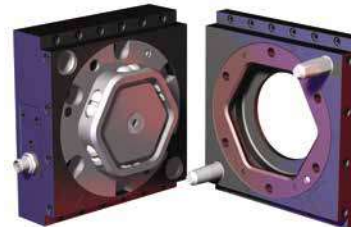
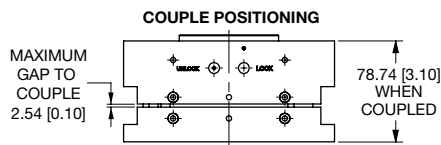

RQC-800 Robot Plate
RTP-800 Tool Plate

RQC-1200/RTP-1200

Combined Weight: 8.3 Kg [18.4 lb]
Max. Payload: 550 Kg [1200 lb]
Max. Moment: 3390 Nm [30000 in-lb]

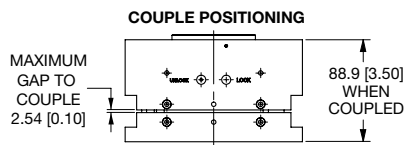

RQC-1200 Robot Plate
RTP-1200 Tool Plate

RQC-2400/RTP-2400

Combined Weight: 30 Kg [66.1 lb]
Max. Payload: 1089 Kg [2400 lb]
Max. Moment: 7000 Nm [61955 in-lb]

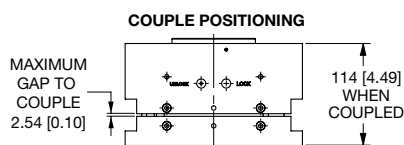

RQC-2400 Robot Plate
RTP-2400 Tool Plate

QC/TP, RHC SERIES

CLICK OR SCAN
To view full catalog pages
on these product

Automatic Tool Changers | Features and Benefits

QC Series Tool Changers



See page 2-5 for
product availability
in your region.

QC-30
Robot
Plate



TP-30
Tool
Plate

Combined Weight: 0.34 Kg [0.75 lbs]
Max. Payload: 13.6 Kg [30 lbs]
Max. Moment: 22.6 Nm [200 in-lbs]

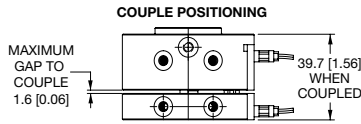

QC-60
Robot
Plate



TP-60
Tool
Plate

Combined Weight: 1.27 Kg [2.8 lbs]
Max. Payload: 27 Kg [60 lbs]
Max. Moment: 88.1 Nm [780 in-lbs]

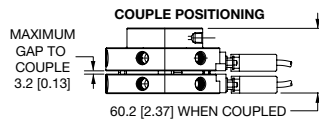

QC-60-10P
Robot
Plate



TP-60-10P
Tool
Plate

Combined Weight: 1.27 Kg [2.8 lbs]
Max. Payload: 27 Kg [60 lbs]
Max. Moment: 88.1 Nm [780 in-lbs]

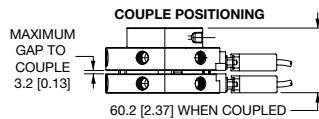

QC-150
Robot
Plate



TP-150
Tool
Plate

Combined Weight: 3.2 Kg [7.1 lbs]
Max. Payload: 68 Kg [150 lbs]
Max. Moment: 215 Nm [1900 in-lbs]

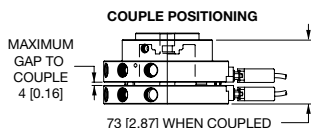

RHC Series Tool Changers



RHC-1-R
Robot
Plate



RHC-1-T
Tool
Plate

Combined Weight: 0.29 Kg [0.63 lbs]
Max. Payload: 9 Kg [20 lbs]
Max. Moment: 28 Nm [250 in-lbs]

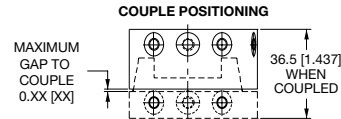

RHC-2-R
Robot
Plate



RHC-2-T
Tool
Plate

Combined Weight: 0.82 Kg [1.81 lbs]
Max. Payload: 59 Kg [130 lbs]
Max. Moment: 136 Nm [1200 in-lbs]

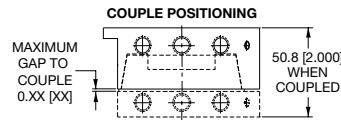

RHC-4-R
Robot
Plate



RHC-3-T
Tool
Plate

Combined Weight: 3.1 Kg [6.8 lbs]
Max. Payload: 136 Kg [300 lbs]
Max. Moment: 1017 Nm [9000 in-lbs]

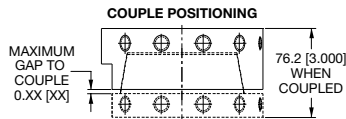

RHC-4-R
Robot
Plate



RHC-4-T
Tool
Plate

Combined Weight: 11 Kg [24.3 lbs]
Max. Payload: 454 Kg [1000 lbs]
Max. Moment: 2825 Nm [25000 in-lbs]

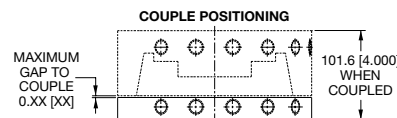

ROBOTIC TOOLING SOLUTIONS

Tool Changer Docking Station

DESTACO offers custom and standard Docking Stations to fit customers needs. Please contact DESTACO Sales for more information.

Key Features:

- Allows for quick changing of tooling
- Reducing machine down-time
- Safely stores tooling when not in use
- Standard or custom stations

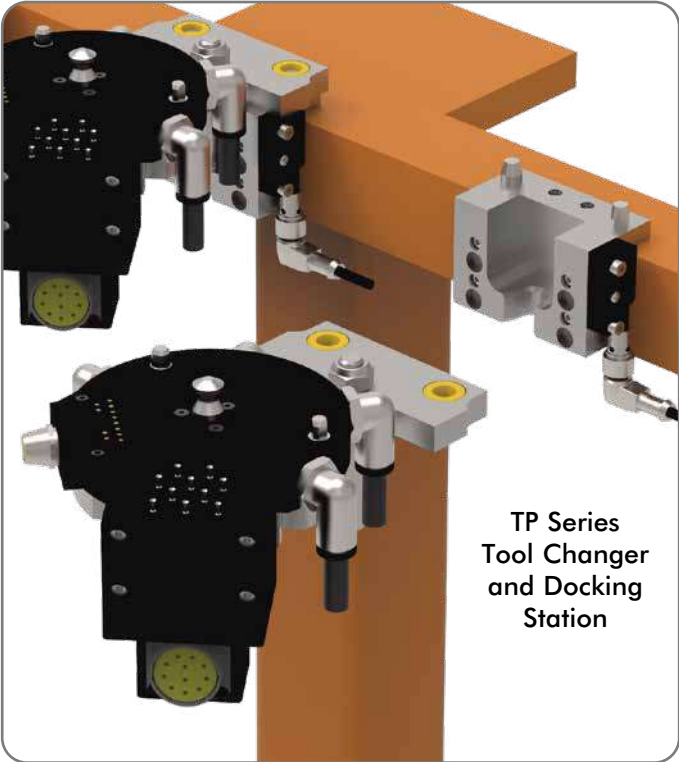
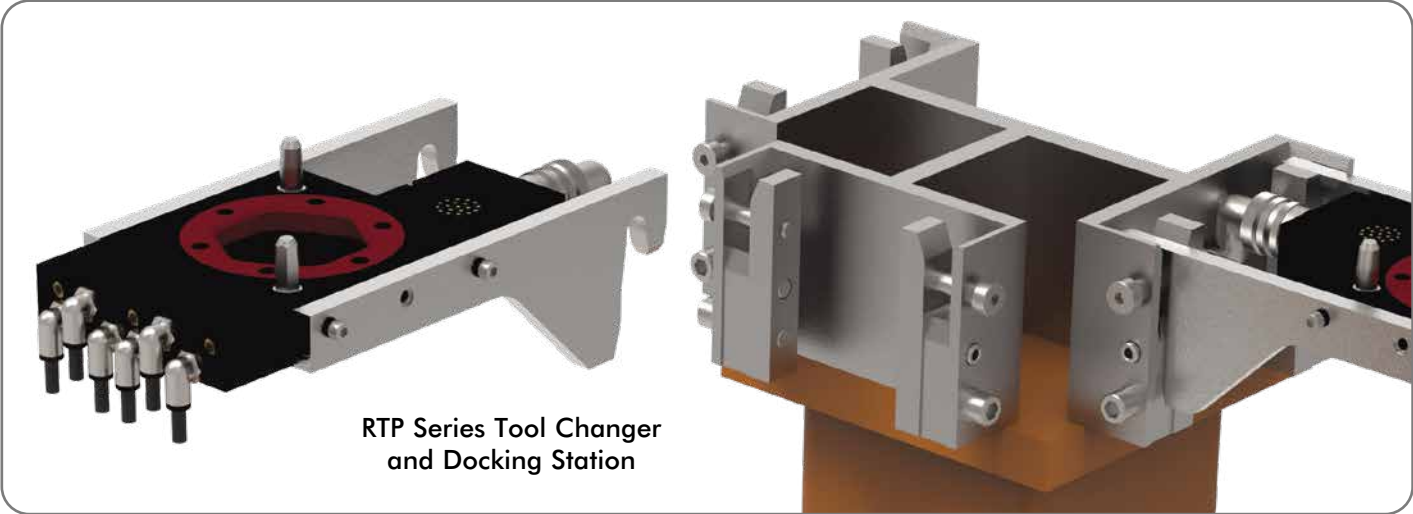

MODULAR MOUNTING SOLUTIONS

Grippers/Slides/Rotaries | Product Overview

DESTACO's modular automation systems feature DIRECTCONNECT™ technology, allowing all components of the system—base slides, block thrusters, thruster slides, grippers, and mounting stanchions—to be mounted together quickly and easily without any adapter plates.

- Reduces engineering design
- Saves \$\$\$ with modular solutions
- Change device orientations quickly
- Eliminates Adapter Plates

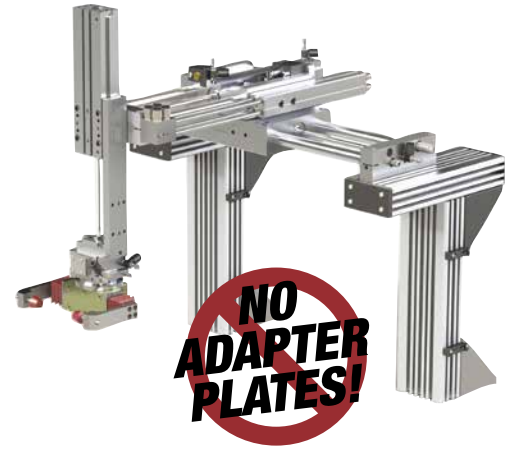

Modular DIRECTCONNECT Mounting Style Examples:

Look for more examples of each main section of the catalog. This is a sample of configurations we offer. Custom solutions also available.

Rotate & Place

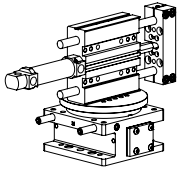

DRF Rotary Actuator
to DLT Linear Slide

Pick & Place

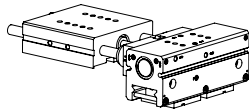

DLT Base Slide to
DPP Parallel Gripper

Place & Place

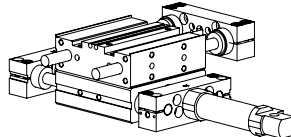

DLB Base Slide to
DLT Linear Slide

Place & Place

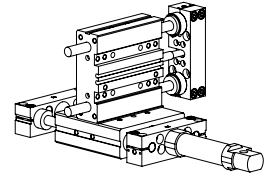

DLB Base Slide to
DLT Linear Slide

Connect Different Sizes & Styles

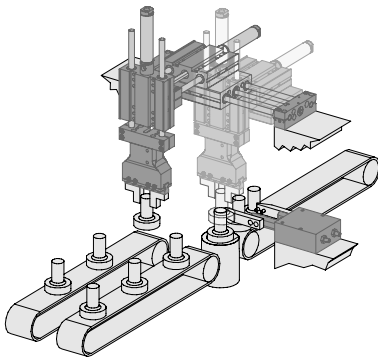

Configure in Multiple Orientations

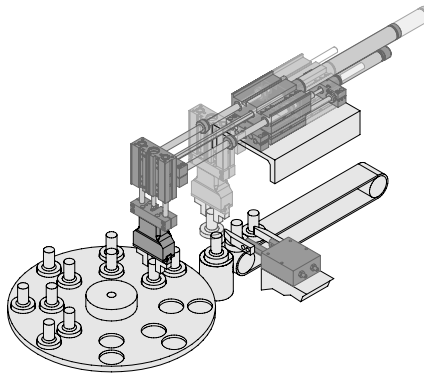

Look for the DIRECTCONNECT Logo

Product Series beginning with the letter D have a DIRECTCONNECT option, with a few exceptions.

DIRECTCONNECT™

HOW TO MAKE A DIRECTCONNECT™ MOUNT

Grippers/Slides/Rotaries | Product Overview

The DIRECTCONNECT Modular Compatibility Chart (on the next page) shows all the products that can easily connect together without adapter plates. Simply locate your first product along the horizontal axis of the top of chart, then locate the second product along the vertical axis on the left side of the chart. If a connection can be made, a mounting pattern will be shown.

DIRECTCONNECT Modular Compatibility Example:

Shown below, a DLB-10,12,16 Base Slide connecting to a DLT-10,12,16 Linear Thruster. Units may connect on different faces of the unit. Please refer to individual datasheets for DIRECTCONNECT mounting surfaces.

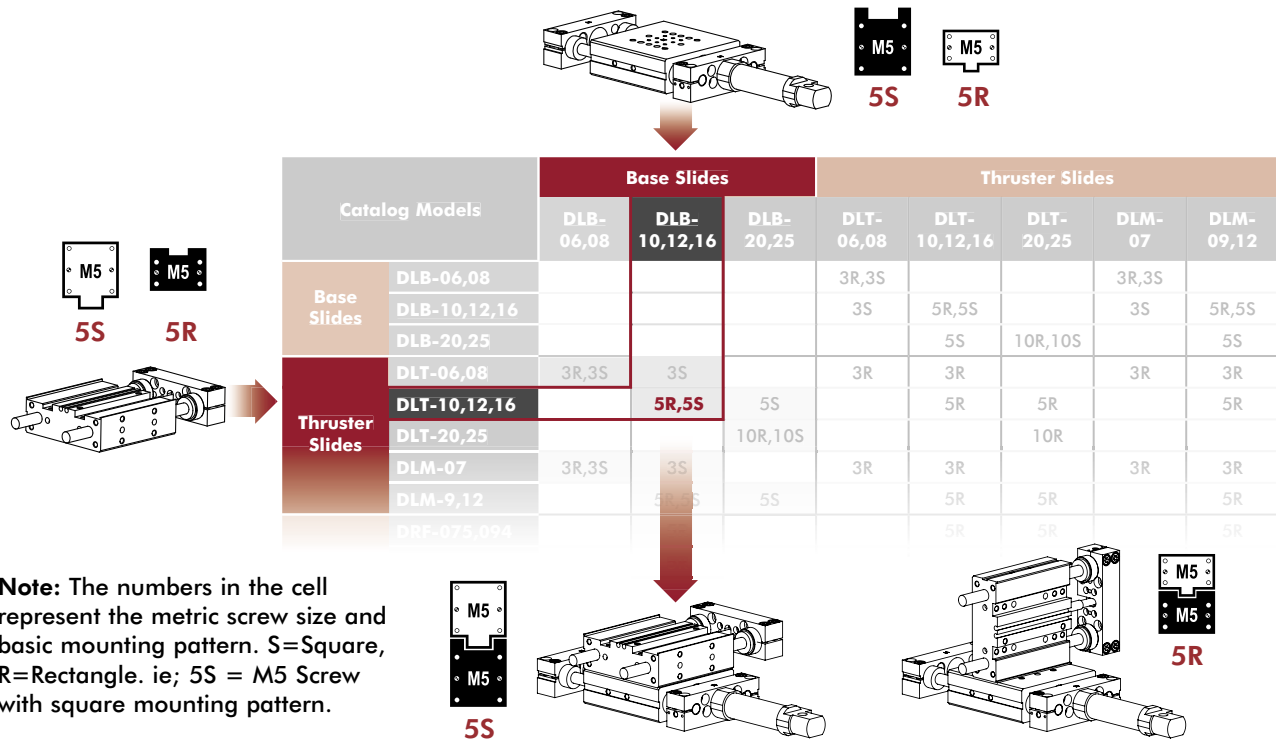

DirectConnect Mounting Surface Example:

Locate matching DIRECTCONNECT mounting pattern icons on the products dimensional drawings to determine what surface faces can be connected to. Corresponding mates equal a DIRECTCONNECT connection.

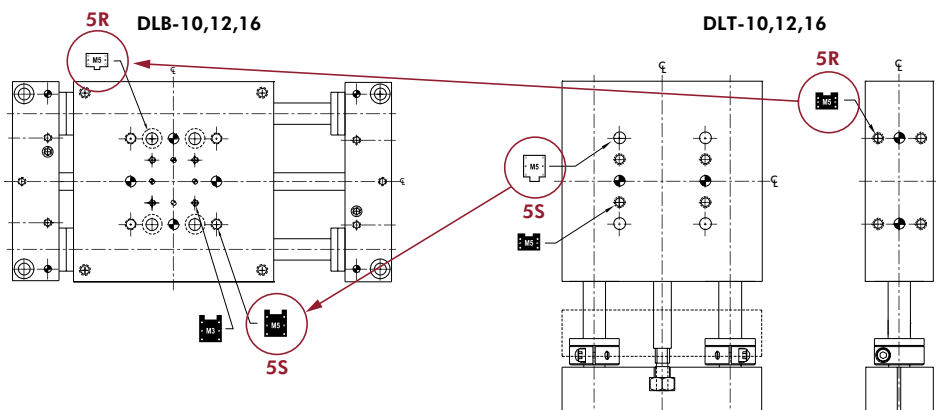

DIRECTCONNECT™ MODULAR COMPATIBILITY CHART

Grippers/Slides/Rotaries | Product Overview

DESTACO's modular automation systems feature DirectConnect™ technology, allowing all components of the system—base slides, block thrusters, thruster slides, and grippers—to be mounted together quickly & easily without any adapter plates. Look for matching icons on product datasheets for mounting compatibility.

Simply locate your first product along the horizontal axis of the top of chart, then locate the second product along the vertical axis on the left side of the chart. If a connection can be made, a mounting pattern will be shown.

Note: The numbers in the cell represent the metric screw size and basic mounting pattern. S=Square, R=Rectangle. ie; 5S = M5 Screw with square mounting pattern.

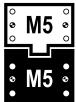
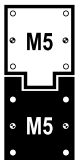

M5 (S)quare M5 (R)ectangle

Catalog Models		Base Slides		
		DLB-06&08	DLB-10,12&16	DLB-20&25
Base Slides	DLB-06 & 08			
	DLB-10, 12 & 16			
	DLB-20 & 25			
Thruster Slides	DLT-06 & 08	3R,3S	3S	
	DLT-10, 12 & 16		5R,5S	5S
	DLT-20 & 25			10R,10S
	DLM-07	3R,3S	3S	
	DLM-9 & 12		5R,5S	5S
Grippers	DGC		5R	
	DPG		5R	
	DCT-12, 16 & 25	3R		
	DCT-25		5R	
	DPDL-047 & 056	3R		
	DPDL-088 & 125		5R	
	DPDL-175 & 250			10R
	DPDS-047 & 056	3R		
	DPDS-088 & 125		5R	
	DPDS-175 & 250			10R
	DPL-25xx		5R	
	DPL-32xx & 40xx			10R
	DPP-10 & 14	3R		
	DPP-20		5R	
	DPP-28		5R	10R
	DPW-250	3R		
	DPW-375 & 500		5R	
	G110-08 & 011	3R		
G110-18 & 25		5R		
DPE-200		5R		
DPE-400			10R	

DIRECTCONNECT™ MODULAR COMPATIBILITY CHART

Grippers/Slides/Rotaries | Product Overview

Thruster Slides				
DLT-06&08	DLT-10,12&16	DLT-20&25	DLM-07	DLM-09&12
3R,3S			3R,3S	
3S	5R,5S		3S	5R,5S
	5S	10R,10S		5S
3R	3R		3R	3R
	5R	5R		5R
		10R		
3R	3R		3R	3R
	5R	5R		5R
	5R	5R		5R
3R	3R		3R	3R
	5R	5R		5R
3R	3R		3R	3R
	5R	5R		5R
		10R		
3R	3R		3R	3R
	5R	5R		5R
		10R		
	5R	5R		5R
		10R		
3R	3R		3R	3R
	5R	5R		5R
	5R	10R		5R
3R	3R		3R	3R
	5R	5R		5R
3R	3R		3R	3R
	5R	5R		5R
	5R	5R		5R
		10R		



PARALLEL GRIPPERS

Sizing and Application Chart

		Jaws		Basic Unit Dimensions mm [in]			Stroke mm [in]
Series	Page #	2 Jaws	3 Jaws	Length	Width	Height	0-6.3 [0-0.25] 6.3-12.7 [0.25-0.50] 12.7-19.1 [0.50-0.75] 19.1-25.4 [0.75-1.00] 25.4-31.8 [1.00-1.25] 31.8-38.1 [1.25-1.50] 38.1-44.5 [1.50-1.75] 44.5-50.8 [1.75-2.00] 50.8-57.1 [2.00-2.25] 57.1-63.5 [2.25-2.50] 63.5-69.8 [2.50-2.75] 69.8-76.2 [2.75-3.00] 76.2+ [3.00+]
		Electric Grippers					
	DPE-200	7	●	67.9 [2.67]	28 [1.10]	128 [5.04]	●
	DPE-400	5	●	159.6 [6.28]	60 [2.36]	129.5 [5.10]	●
	RPE-100	9	●	32 [1.26]	40 [1.57]	94 [3.70]	●
Precision Grippers		GR-PRC-#					
	6002P	5	●	72 [2.83]	60 [2.36]	77 [3.03]	●
	6002P-C	5	●	78 [3.07]	60 [2.36]	77 [3.03]	●
	8002P	6	●	91.6 [3.61]	80 [3.15]	78 [3.07]	●
	8002P-C	6	●	98.4 [3.87]	80 [3.15]	78 [3.07]	●
	11002P	7	●	126 [4.96]	110 [4.33]	106 [4.17]	●
	11002P-C	7	●	136 [5.35]	110 [4.33]	106 [4.17]	●
	1400P	8	●	165 [6.50]	140 [5.51]	137 [5.39]	●
	14002P-C	8	●	179 [7.05]	140 [5.51]	137 [5.39]	●
	16002P	9	●	194 [7.64]	165 [6.50]	169 [6.65]	●
	16002P-C	9	●	204 [8.03]	165 [6.50]	169 [6.65]	●
16502PGR	10	●	210 [8.27]	165 [6.50]	262 [10.31]	●	
	DGC-25	17	●	75 [2.95]	38 [1.50]	55 [2.17]	●
	DGC-45	18	●	95 [3.74]	42 [1.65]	70 [2.76]	●
	DGC-65	19	●	125 [4.92]	53 [2.09]	90 [3.54]	●
	GC-85	20	●	155 [6.10]	67.5 [2.66]	120 [4.72]	●
	GC-105	21	●	190 [7.48]	85.5 [3.37]	145 [5.71]	●
	DPL-2520	25	●	152 [5.98]	75 [2.95]	65 [2.56]	●
	DPL-2535	26	●	197 [7.76]	75 [2.95]	65 [2.56]	●
	DPL-3230	27	●	186 [7.32]	93 [3.66]	74 [2.91]	●
	DPL-3250	28	●	246 [9.69]	93 [3.66]	74 [2.91]	●
	DPL-4040	29	●	238 [9.37]	112 [4.41]	91 [3.58]	●
DPL-4070	30	●	328 [12.91]	112 [4.41]	91 [3.58]	●	
	DPP-10M-06	35	●	62.9 [2.48]	25 [0.98]	34.67 [1.36]	●
	DPP-10M-12	35	●	73.7 [2.90]	25 [0.98]	34.67 [1.36]	●
	DPP-14M-15	36	●	90.2 [3.55]	34 [1.34]	42.21 [1.66]	●
	DPP-14M-25	36	●	118.7 [4.67]	34 [1.34]	42.21 [1.66]	●
	DPP-20M-25	37	●	129 [5.08]	46 [1.81]	55.63 [2.19]	●
	DPP-20M-38	37	●	175.5 [6.91]	46 [1.81]	55.63 [2.19]	●
	DPP-28M-31	38	●	162.3 [6.39]	58 [2.28]	72.54 [2.86]	●
	DPP-28M-50	38	●	221.5 [8.72]	58 [2.28]	72.54 [2.86]	●

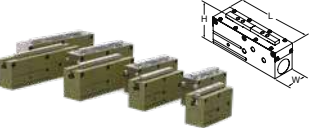
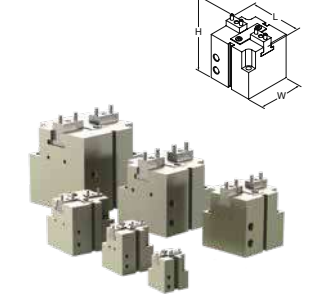
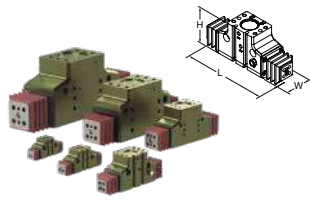
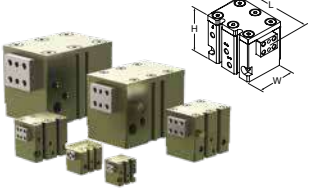

PARALLEL GRIPPERS

Sizing and Application Chart

	Series	Page #	Jaws		Basic Unit Dimensions mm [in]			Stroke mm [in]														
			2 Jaws	3 Jaws	Length	Width	Height	0-6.3 [0-0.25]	6.3-12.7 [0.25-0.50]	12.7-19.1 [0.50-0.75]	19.1-25.4 [0.75-1.00]	25.4-31.8 [1.00-1.25]	31.8-38.1 [1.25-1.50]	38.1-44.5 [1.50-1.75]	44.5-50.8 [1.75-2.00]	50.8-57.1 [2.00-2.25]	57.1-63.5 [2.25-2.50]	63.5-69.8 [2.50-2.75]	69.8-76.2 [2.75-3.00]	76.2+ [3.00+]		
Precision Grippers (cont.)													GR-PRC-#									
	RP-50P	41	●		57 [2.24]	25.4 [1.00]	46.7 [1.84]	●														
	RP-100P	42	●		83 [3.27]	25.4 [1.00]	59.4 [2.34]	●	●													
	RP-25P	43	●		108 [4.25]	31.8 [1.25]	81.1 [3.19]	●	●	●												
	RP-35P	44	●		143 [5.63]	50.8 [2.00]	103.2 [4.06]	●	●	●	●											
	RP-40P	45	●		178 [7.01]	[2.25] 57.2	125 [4.92]	●	●	●	●	●										
	RP-43P	46	●		292 [11.50]	74.7 [2.94]	175 [6.89]	●	●	●	●	●	●									
	RPL/RPLC-1	49	●		44.5 [1.75]	19.1 [0.75]	29.5 [1.16]	●														
	RPL/RPLC-2	49	●		59.5 [2.34]	19.1 [0.75]	29.5 [1.16]	●	●													
	RPL/RPLC-3	50	●		80 [3.15]	22.2 [0.87]	32.6 [1.28]	●	●	●												
	RPL/RPLC-4	50	●		98.1 [3.86]	22.2 [0.87]	32.6 [1.28]	●	●	●	●											
General Industrial Grippers													GR-GEN-#									
	CP-1	5	●		37.6 [1.48]	30 [1.18]	39.2 [1.54]	●														
	CP-1-C	5	●		42 [1.65]	30 [1.18]	39.2 [1.54]	●														
	CP-2	6	●		51.4 [2.02]	40 [1.57]	51.5 [2.03]	●														
	CP-2-C	6	●		58.2 [2.29]	40 [1.57]	51.5 [2.03]	●	●													
	CP-3	7	●		70 [2.76]	55 [2.17]	67 [2.64]	●	●													
	CP-3-C	7	●		81.2 [3.20]	55 [2.17]	67 [2.64]	●	●	●												
	CP-4	8	●		85 [3.35]	65 [2.56]	74 [2.91]	●	●	●												
	CP-4-C	8	●		96 [3.78]	65 [2.56]	74 [2.91]	●	●	●	●											
	CP-5	9	●		102 [4.02]	80 [3.15]	91 [3.58]	●	●	●												
	CP-5-C	9	●		120 [4.72]	80 [3.15]	91 [3.58]	●	●	●	●											
	CP-6	10	●		125 [4.92]	100 [3.94]	114 [4.49]	●	●	●	●											
	CP-6-C	10	●		141 [5.55]	100 [3.94]	114 [4.49]	●	●	●	●	●										
	DPDL-047	13	●		54.5 [2.16]	22.2 [0.875]	32.2 [1.27]	●	●													
	DPDL-056	14	●		68.7 [2.70]	24.1 [0.950]	37.7 [1.48]	●	●													
	DPDL-088	15	●		101.1 [3.98]	36.1 [1.420]	56 [2.20]	●	●	●												
	DPDL-125	16	●		128.4 [5.06]	43.2 [1.700]	68.5 [2.70]	●	●	●	●											
	DPDL-175	17	●		183.1 [7.21]	64.8 [2.550]	100.2 [3.94]	●	●	●	●	●										
	DPDL-250	18	●		243.8 [9.58]	79.3 [3.125]	123.3 [4.85]	●	●	●	●	●	●									
	DPDS-047	21	●		31.2 [1.23]	22.2 [0.87]	25.9 [1.02]	●														
	DPDS-056	22	●		39.8 [1.57]	24.1 [0.95]	28.9 [1.14]	●														
	DPDS-088	23	●		57.4 [2.26]	36.1 [1.42]	43.4 [1.71]	●														
	DPDS-125	24	●		73.5 [2.89]	43.2 [1.70]	52.7 [2.07]	●	●													
	DPDS-175	25	●		114.7 [4.52]	64.8 [2.55]	80.4 [3.17]	●	●	●												
	DPDS-250	26	●		133.1 [5.24]	79.3 [3.12]	95.5 [3.76]	●	●	●	●											
	DPG-10M-1	29	●		62 [2.44]	34.9 [1.37]	44.9 [1.77]	●														
	DPG-10M-2	29	●		86 [3.39]	34.9 [1.37]	44.9 [1.77]	●	●													
	DPG-10M-3	29	●		113 [4.45]	34.9 [1.37]	44.9 [1.77]	●	●	●												
	DPG-10M-4	29	●		137 [5.39]	34.9 [1.37]	44.9 [1.77]	●	●	●	●											

PARALLEL GRIPPERS

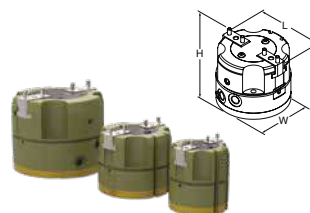
Sizing and Application Chart

Series	Page #	Jaws		Basic Unit Dimensions mm [in]			Stroke mm [in]															
		2 Jaws	3 Jaws	Length	Width	Height	0-6.3 [0-0.25]	6.3-12.7 [0.25-0.50]	12.7-19.1 [0.50-0.75]	19.1-25.4 [0.75-1.00]	25.4-31.8 [1.00-1.25]	31.8-38.1 [1.25-1.50]	38.1-44.5 [1.50-1.75]	44.5-50.8 [1.75-2.00]	50.8-57.1 [2.00-2.25]	57.1-63.5 [2.25-2.50]	63.5-69.8 [2.50-2.75]	69.8-76.2 [2.75-3.00]	76.2+ [3.00+]			
General Industrial Grippers (cont.)													GR-GEN-#									
	RDH-1	33	●	63 [2.48]	33 [1.30]	38.5 [1.52]	●															
	RDH-1-L	33	●	63 [2.48]	33 [1.30]	38.5 [1.52]	●●															
	RDH-2	34	●	83 [3.27]	40 [1.57]	58 [2.28]	●															
	RDH-2-L	34	●	83 [3.27]	40 [1.57]	58 [2.28]	●●															
	RDH-3	35	●	104 [4.09]	50 [1.97]	66 [2.60]	●●															
	RDH-3-L	35	●	104 [4.09]	50 [1.97]	66 [2.60]	●●●															
	RDH-4	36	●	129 [5.08]	60 [2.36]	74.5 [2.93]	●●															
	RDH-4-L	36	●	129 [5.08]	60 [2.36]	74.5 [2.93]	●●●															
	RDH-5	37	●	162 [6.38]	76 [2.99]	90.5 [3.56]	●●●															
	RDH-5-L	37	●	162 [6.38]	76 [2.99]	90.5 [3.56]	●●●●															
	RDH-6	38	●	205 [8.07]	100 [3.94]	113 [4.45]	●●●															
	RDH-6-L	38	●	205 [8.07]	100 [3.94]	113 [4.45]	●●●●															
	RDH-7	39	●	258 [10.16]	120 [4.72]	147 [5.79]	●●●●															
	RDH-7-L	39	●	258 [10.16]	120 [4.72]	147 [5.79]	●●●●●															
	RDH-8	40	●	355 [13.98]	180 [7.09]	201 [7.91]	●●●●●															
RDH-8-L	40	●	355 [13.98]	180 [7.09]	201 [7.91]	●●●●●●																
	REP-62	43	●	70 [2.76]	60 [2.36]	72 [2.83]	●●															
	REP-62-C	43	●	82 [3.23]	60 [2.36]	72 [2.83]	●●●															
	REP-82	44	●	94 [3.70]	80 [3.15]	74 [2.91]	●●															
	REP-82-C	44	●	108 [4.25]	80 [3.15]	74 [2.91]	●●●															
	REP-112	45	●	138 [5.43]	110 [4.33]	98 [3.86]	●●															
	REP-112-C	45	●	158 [6.22]	110 [4.33]	98 [3.86]	●●●															
	RP-5	49	●	29 [1.14]	25.4 [1.00]	36.5 [1.44]	●															
	RP-10	50	●	38.1 [1.50]	31.7 [1.25]	37.3 [1.47]	●															
	RP-11	53	●	48 [1.89]	31.8 [1.25]	28.6 [1.13]	●															
	RP-11-D	53	●	45 [1.77]	31.8 [1.25]	28.6 [1.13]	●															
	RP-12	54	●	63 [2.48]	31.8 [1.25]	35.6 [1.40]	●●															
	RP-12-D	54	●	60 [2.36]	31.8 [1.25]	35.6 [1.40]	●															
	RP-15	55	●	81 [3.19]	41.3 [1.63]	47.3 [1.86]	●●															
	RP-15-D	55	●	76 [2.99]	41.3 [1.63]	47.3 [1.86]	●●															
	RP-17	56	●	108 [4.25]	54 [2.13]	61.9 [2.44]	●●●															
	RP-17-D	56	●	117 [4.61]	54 [2.13]	61.9 [2.44]	●●●●															
	RP-18	57	●	177 [6.97]	74.9 [2.95]	92.8 [3.65]	●●●●															
	RP-18-D	57	●	190 [7.48]	74.9 [2.95]	92.8 [3.65]	●●●●●															
	RP-19	58	●	266 [10.47]	100.3 [3.95]	118.7 [4.67]	●●●●●															
RP-19-D	58	●	254 [10.00]	100.3 [3.95]	118.7 [4.67]	●●●●●																

PARALLEL GRIPPERS

Sizing and Application Chart

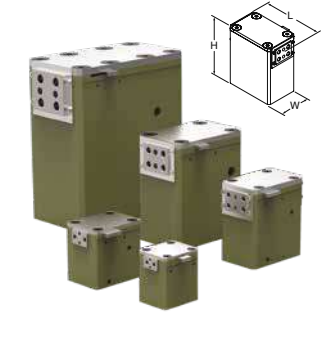
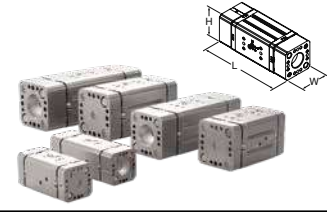
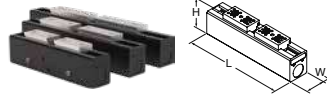
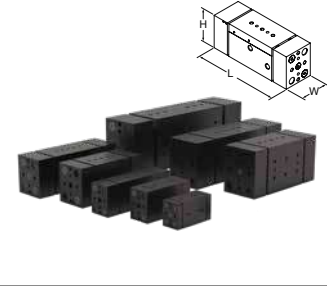
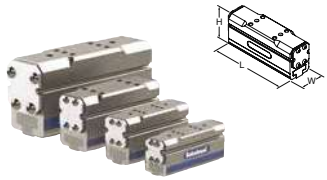
	Series	Page #	Jaws		Basic Unit Dimensions mm [in]			Stroke mm [in]									
			2 Jaws	3 Jaws	Length	Width	Height	0-6.3 [0-0.25]	6.3-12.7 [0.25-0.50]	12.7-19.1 [0.50-0.75]	19.1-25.4 [0.75-1.00]	25.4-31.8 [1.00-1.25]	31.8-38.1 [1.25-1.50]	38.1-44.5 [1.50-1.75]	44.5-50.8 [1.75-2.00]	50.8-57.1 [2.00-2.25]	57.1-63.5 [2.25-2.50]
General Industrial Grippers (cont.)																	
GR-GEN-#																	
	RPM/RPMC-1	61	●		23 [0.91]	16 [0.63]	24 [0.94]	●									
	RPM/RPMC-2	61	●		24 [0.94]	16 [0.63]	25.5 [1.00]	●									
	RPM/RPMC-3	62	●		30 [1.18]	16 [0.63]	25.5 [1.00]	●									
	RPS-11	65	●		48 [1.88]	31.8 [1.25]	44.1 [1.74]	●									
	RPS-11-D	65	●		45 [1.79]	31.8 [1.25]	44.1 [1.74]	●									
	RPS-12	66	●		63 [2.50]	31.8 [1.25]	51.2 [2.02]	●	●								
	RPS-12-D	66	●		60 [2.37]	31.8 [1.25]	51.2 [2.02]	●									
	RPS-15	67	●		81 [3.19]	41.3 [1.63]	71.6 [2.82]	●	●								
	RPS-15-D	67	●		76 [3.00]	41.3 [1.63]	71.6 [2.82]	●	●								
	RPS-17	68	●		107 [4.25]	54.0 [2.13]	98.7 [3.89]	●	●								
	RPS-17-D	68	●		117 [4.60]	54.0 [2.13]	98.7 [3.89]	●	●								
	RPS-18	69	●		177 [7.00]	74.9 [2.95]	154.4 [6.08]	●	●								
	RPS-18-D	69	●		190 [7.45]	74.9 [2.95]	154.4 [6.08]	●	●								
Heavy-Duty Grippers																	
GR-HDP-#																	
	DPW-250-1	5	●		98 [3.86]	37.6 [1.48]	37.6 [1.48]	●	●								
	DPW-250-2	5	●		136 [5.35]	37.6 [1.48]	37.6 [1.48]	●	●								
	DPW-375-1	6	●		122 [4.80]	54 [2.13]	54 [2.13]	●	●								
	DPW-375-2	6	●		198 [7.80]	54 [2.13]	54 [2.13]	●	●								
	DPW-500-1	7	●		164 [6.46]	63 [2.48]	63 [2.48]	●	●								
	DPW-500-2	7	●		240 [9.45]	63 [2.48]	63 [2.48]	●	●								
	RPB-24	11	●		438.2 [17.25]	88.9 [3.50]	129 [5.08]	●	●								
	RPB-26	11	●		590.5 [23.25]	88.9 [3.50]	129 [5.08]	●	●								
	RPB-28	11	●		734 [28.90]	88.9 [3.50]	129 [5.08]	●	●								
	RPW-250	15	●		93 [3.66]	31.5 [1.24]	40.9 [1.61]	●	●								
	RPW-375-1	16	●		120 [4.72]	37.8 [1.49]	50.5 [1.99]	●	●								
	RPW-375-2	16	●		187 [7.36]	37.8 [1.49]	50.5 [1.99]	●	●								
	RPW-500-1	17	●		171 [6.73]	56.9 [2.24]	66.4 [2.61]	●	●								
	RPW-500-2	17	●		234 [9.21]	56.9 [2.24]	66.4 [2.61]	●	●								
	RPW-625-1	18	●		219 [8.62]	66.4 [2.61]	82.3 [3.24]	●	●								
	RPW-625-2	18	●		321 [12.64]	66.4 [2.61]	82.3 [3.24]	●	●								
RPW-750	19	●		410 [16.14]	75 [2.95]	99.8 [3.93]	●	●									
OEM Grippers																	
GR-OEM-#																	
	G110-08M	7	●		[1.69-4.06] 43-103	20 [0.79]	28 [1.10]	●	●								
	G110-11M	9	●		[1.69-4.06] 43-103	24 [0.94]	36.5 [1.44]	●	●								
	G110-18M	11	●		[2.13-4.92] 54-125	30 [1.18]	43 [1.69]	●	●								
	G110-25M	13	●		[2.87-7.60] 73-193	40 [1.57]	61 [2.40]	●	●								

PARALLEL GRIPPERS

Sizing and Application Chart

	Series	Page #	Jaws		Basic Unit Dimensions mm [in]		Stroke mm [in]															
			2 Jaws	3 Jaws	Diameter	Height	0-6.3 [0-0.25]	6.3-12.7 [0.25-0.50]	12.7-19.1 [0.50-0.75]	19.1-25.4 [0.75-1.00]	25.4-31.8 [1.00-1.25]	31.8-38.1 [1.25-1.50]	38.1-44.5 [1.50-1.75]	44.5-50.8 [1.75-2.00]	50.8-57.1 [2.00-2.25]	57.1-63.5 [2.25-2.50]	63.5-69.8 [2.50-2.75]	69.8-76.2 [2.75-3.00]	76.2+ [3.00+]			
Three Jaw Grippers													GR-3JP-#									
	6003P	5	●	72 [2.83]	77 [3.03]	●●																
	6003P-C	5	●	78 [3.07]	77 [3.03]	●●●																
	8003P	6	●	91.6 [3.61]	78 [3.07]	●●●	●															
	8003P-C	6	●	98.4 [3.87]	78 [3.07]	●●●●																
	11003P	7	●	126 [4.96]	106 [4.17]	●●●●	●●															
	11003P-C	7	●	136 [5.35]	106 [4.17]	●●●●●																
	14003P	8	●	165 [6.50]	137 [5.39]	●●●●●	●●●															
	14003P-C	8	●	179 [7.05]	137 [5.39]	●●●●●●																
	16503P	9	●	194 [7.64]	169 [6.65]	●●●●●●	●●●●															
	16503P-C	9	●	204 [8.03]	169 [6.65]	●●●●●●●																
	RTH-1M	17	●	63 [2.48]	43 [1.69]	●																
	RTH-1M-L	17	●	63 [2.48]	43 [1.69]	●●																
	RTH-2M	18	●	83 [3.27]	57 [2.24]	●																
	RTH-2M-L	18	●	83 [3.27]	57 [2.24]	●●																
	RTH-3M	19	●	83 [3.27]	57 [2.24]	●●																
	RTH-3M-L	19	●	83 [3.27]	57 [2.24]	●●●																
	RTH-4M	20	●	129 [5.08]	84.5 [3.48]	●●																
	RTH-4M-L	20	●	129 [5.08]	84.5 [3.48]	●●●●																
	RTH-5M	21	●	162 [6.38]	98.5 [3.84]	●●	●															
	RTH-5M-L	21	●	162 [6.38]	98.5 [3.84]	●●●●	●●															
	RTH-6M	22	●	205 [8.07]	121 [4.76]	●●	●●															
	RTH-6M-L	22	●	205 [8.07]	121 [4.76]	●●●●	●●●															
RTH-7M	23	●	258 [10.16]	155 [6.10]	●●	●●●																
RTH-7M-L	23	●	258 [10.16]	155 [6.10]	●●●●	●●●●																
RTH-8M	24	●	355 [13.98]	209 [8.23]	●●	●●●●																
RTH-8M-L	24	●	355 [13.98]	209 [8.23]	●●●●●	●●●●●																
	PPC-12	27	●	43 [1.69]	74 [2.91]	●●																
	PPC-12-C	27	●	49.03 [1.93]	78 [3.07]	●●●																
	PPC-25	28	●	61.5 [2.42]	87 [3.43]	●●																
	PPC-25-C	28	●	68.5 [2.70]	92 [3.62]	●●●																
	PPC-34	29	●	82.5 [3.25]	112 [4.41]	●●	●●															
	PPC-34-C	29	●	92.5 [3.64]	117 [4.61]	●●●	●															
	REP-63	33	●	72 [2.83]	77 [3.03]	●●																
	REP-63-C	33	●	78 [3.07]	77 [3.03]	●●●																
	REP-83	34	●	91.6 [3.61]	78 [3.07]	●●																
	REP-83-C	34	●	98.4 [3.87]	78 [3.07]	●●●																
	REP-113	35	●	126 [4.96]	103 [4.06]	●●	●●															
	REP-113-C	35	●	136 [5.35]	103 [4.06]	●●●	●															
	RPC-315	39	●	62 [2.44]	41 [1.61]	●●																
	RPC-320	40	●	82 [3.23]	50 [1.97]	●●																
	RPC-331	41	●	118 [4.65]	75.1 [2.96]	●●	●															
	RPC-344	42	●	140 [5.51]	82.2 [3.24]	●●	●●															
	RPC-356	43	●	180 [7.24]	101.1 [3.98]	●●	●●●															
	RPC-368	44	●	206 [8.11]	118 [4.65]	●●	●●●															



PARALLEL GRIPPERS

Sizing and Application Chart

Total Gripforce N [lbs]	Maximum Finger Length @ 60psi mm [in]	Actuation Time	Operating Pressure bar [psi]	Environ- ment	Features
0.45-45 [1-10]	0-50.8 [0-2]	0.05-0.1 sec.	5-100 [0.3-7]	Clean Room Environment	Three Jaw Grippers
45-111 [10-25]	50.8-102 [2-4]	0.1-0.5 sec.	20-100 [1.5-7]	Normal Environment	✓
111-223 [25-50]	102-152 [4-6]	0.5-0.75 sec.	30-100 [2-7]	Harsh/Dirty Environment	✓
223-445 [50-100]	152-203 [6-8]	0.75-1 sec.	40-100 [3-7]	Failsafe Operation	✓
445-2225 [100-500]	203-254 [8-10]		45-100 [3.1-7]	Inductive Sensors	✓
2225-13350 [500-3000]	254-305 [10-12]		50-100 [3.5-7]	Magneto Resistive Sensors	✓
	305-356 [12-14]		55-100 [3.8-7]	Double Acting Cylinder	✓
	356-406 [14-16]		60-100 [4-7]	Single Acting/Spring Return	✓
	406-457 [16-18]		70-150 [5-7]	Double Acting/Spring Assist	✓
	457-508 [18-20]			Non-Synchronous Option	✓
	508+ [20 +]				✓

ANGULAR GRIPPERS

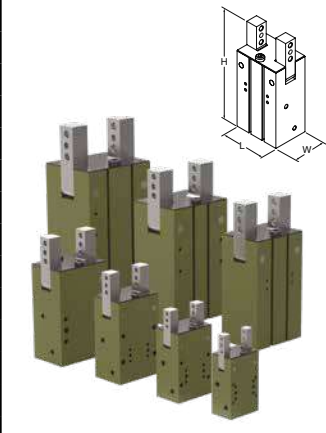
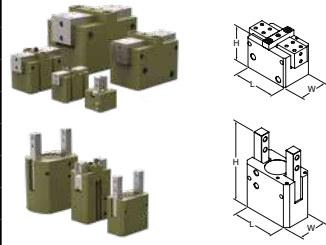
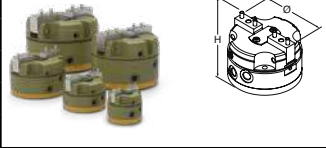
Sizing and Application Chart

Series	Page #	Jaws		Basic Unit Dimensions mm [in]			Angle (Both Jaws)				Total Gripforce N [lbs]
		2 Jaws	3 Jaws	Length	Width	Height	12 Degrees	30 Degrees	70 Degrees	180 Degrees	0.45-45 [1-10] 45-111 [10-25] 111-223 [25-50] 223-445 [50-100] 445-2225 [100-500] 2225-13350 [500-3000]
Angular Grippers											
GR-ANG-#											
	CT-12M	5	●	30 [1.18]	20 [0.79]	48 [1.89]				●	●
	CT-12M-RE	5	●	30 [1.18]	20 [0.79]	64 [2.52]				●	●
	CT-16M	6	●	36 [1.42]	25 [0.98]	64 [2.52]				●	●●
	CT-16M-RE	6	●	36 [1.42]	25 [0.98]	71 [2.80]				●	●●
	CT-20M	7	●	42 [1.65]	30 [1.18]	79 [3.11]				●	●
	CT-20M-RE	7	●	42 [1.65]	30 [1.18]	83 [3.27]				●	●●●
	CT-25M	8	●	50 [1.97]	36 [1.42]	93.5 [3.68]				●	●●●
	CT-25M-RE	8	●	50 [1.97]	36 [1.42]	102 [4.02]				●	●●●
	CT-32M	9	●	56 [2.20]	42 [1.65]	95 [3.74]				●	●●●●
	CT-32M-RE	9	●	56 [2.20]	42 [1.65]	116 [4.57]				●	●●●●
	CT-40M	10	●	66 [2.60]	52 [2.05]	107.5 [4.23]				●	●●●
	CT-40M-RE	10	●	66 [2.60]	52 [2.05]	135 [5.31]				●	●●●●
CT-50M	11	●	76 [2.99]	62 [2.44]	146 [5.75]				●	●●●●	
CT-50M-RE	11	●	76 [2.99]	62 [2.44]	163 [6.42]				●	●●●●	
	RA-5	15	●	25.4 [1.00]	38.1 [1.50]	35.0 [1.38]				●	●●
	RA-6	16	●	38.1 [1.50]	50.8 [2.00]	49.6 [1.95]				●	●●
	RA-7	17	●	50.8 [2.00]	76.2 [3.00]	60.8 [2.39]				●	●●●
	RA-8	18	●	76.2 [3.00]	101.6 [4.00]	76.2 [3.00]				●	●●
	RA-10	19	●	25.4 [1.00]	25.4 [1.00]	20.7 [0.81]				●	●●
	RA-15	23	●	25.4 [1.00]	44.5 [1.75]	38.9 [1.53]	●				●●●
	RA-25	24	●	44.5 [1.75]	63.5 [2.50]	61.9 [2.44]	●				●●●
	RA-90	25	●	39 [1.54]	28 [1.10]	67.3 [2.65]			●		●●
	RUA-62M	29	●		Ø60 [Ø2.36]	53 [2.09]				●	●●
	RUA-82M	30	●		Ø80 [Ø3.15]	57 [2.24]				●	●●
	RUA-112M	31	●		Ø110 [Ø4.33]	175 [6.89]				●	●●
	RUA-142M	32	●		Ø140 [Ø5.51]	107 [4.21]				●	●●●
	RUA-162M	33	●		Ø165 [Ø6.50]	119 [4.69]				●	●●●
GR-SPC-#											
	FUA-50M	2	●	85 [3.35]	75 [2.95]	52 [2.05]				●	See Datasheet
	FUA-63M	3	●	100 [3.90]	90 [3.54]	62 [2.44]				●	See Datasheet

ROTARY ACTUATORS

Sizing and Application Chart

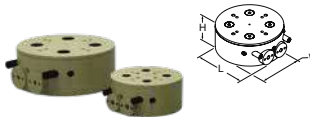
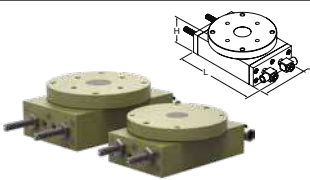
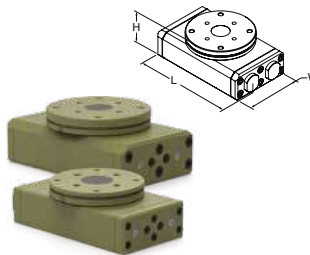
	Series	Page #	Ports/ Mounting		Rotary Type		Basic Unit Dimensions mm [in]			Maximum Torque Nm [in-lb]						
			Imperial	Metric	Flange Output	Shaft Output	Length	Width	Height	0-111 [0-25]	111-223 [25-50]	223-445 [50-100]	445-678 [100-150]	678-890 [150-200]	890-1335 [200-300]	1335+ [300+]
RR-Light Duty		GR-ROT-#														
	RR-18/-18M	5	●	●	●		61 [2.42]	57.1 [2.25]	24.6 [.969]	●						
	RR-28/-28M	6	●	●	●		83.1 [3.28]	85.7 [3.375]	33.1 [1.313]	●						
RR-Medium Duty		GR-ROT-#														
	RR-36/-36M	9	●	●	●		170.9 [6.73]	101.6 [4.00]	43.7 [1.72]	●						
	RR-46/-46M	10	●	●	●		203.2 [8.00]	113.5 [4.47]	54.1 [2.13]	●—●						
RR-Heavy Duty		GR-ROT-#														
	RR-56M	13	●	●	●		[8.50] 215.9	117.5 [4.63]	70.2 [2.77]	●—●						
	RR-66M	14	●	●	●		[10.35] 262.8	158.8 [6.25]	96.8 [3.81]	●—●						

LINEAR SLIDES

Sizing and Application Chart

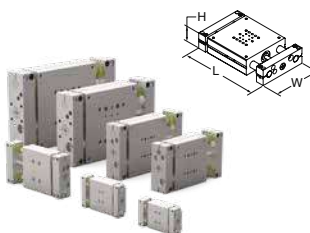
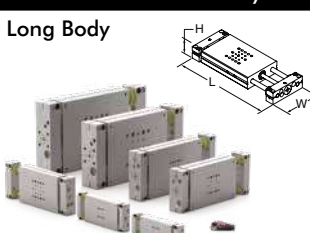
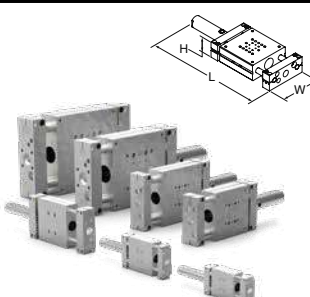
Series	Slide Type			Basic Unit Dimensions mm [in]			Maximum Thrust Force N [lbs]							
	Page #	Base Slide	Thruster Slide	Lift/Block Thruster	Length + Stroke	Width	Height	0-111 [0-25]	111-223 [25-50]	223-445 [50-100]	445-678 [100-150]	678-890 [150-200]	890-1335 [200-300]	1335+ [300+]
Base Slide—Internal Air Cylinder														
GR-LIN-#														
	DLB-06M-B	5	●		81 [3.19]	50.3 [1.98]	23.7 [0.93]	●						
	DLB-08M-B	5	●		93.7 [3.69]	62.7 [2.47]	23.7 [0.93]	●						
	DLB-10M-B	7	●		143 [5.63]	88.6 [3.49]	31.6 [1.24]	●	●					
	DLB-12M-B	7	●		155.7 [6.13]	101.2 [3.98]	42.1 [1.66]	●	●	●				
	DLB-16M-B	7	●		174.8 [6.88]	120.3 [4.74]	42.1 [1.66]	●	●	●				
	DLB-20M-B	9	●		239.3 [9.42]	164.6 [6.48]	55.4 [2.18]	●	●	●	●			
	DLB-25M-B	9	●		275.3 [10.84]	190 [7.48]	55.4 [2.18]	●	●	●	●	●		
Base Slide—Internal Air Cylinder														
GR-LIN-#														
	DLB-06M-L	6	●		125.5 [4.94]	50.3 [1.98]	23.7 [0.93]	●						
	DLB-08M-L	6	●		138.2 [5.44]	62.7 [2.47]	23.7 [0.93]	●						
	DLB-10M-L	8	●		193.8 [7.63]	88.6 [3.49]	31.6 [1.24]	●	●					
	DLB-12M-L	8	●		219.2 [8.63]	101.2 [3.98]	42.1 [1.66]	●	●	●				
	DLB-16M-L	8	●		244.6 [9.63]	120.3 [4.74]	42.1 [1.66]	●	●	●				
	DLB-20M-L	10	●		290.1 [11.42]	164.6 [6.48]	55.4 [2.18]	●	●	●	●			
	DLB-25M-L	10	●		326.1 [12.84]	190 [7.48]	55.4 [2.18]	●	●	●	●	●		
Linear Thruster Slide—External Cylinder														
GR-LIN-#														
	DLB-06-T	14	●		129.4 [5.09]	50.3 [1.98]	23.7 [0.93]	●						
	DLB-08-T	14	●		142.1 [5.59]	62.7 [2.47]	23.7 [0.93]	●						
	DLB-10-T, A	15	●		237.4 [9.35]	88.6 [3.49]	31.6 [1.24]	●	●					
	DLB-12-T, A	15	●		253.6 [9.98]	101.2 [3.98]	42.1 [1.66]	●	●	●				
	DLB-16-T, A	15	●		272.6 [10.73]	120.3 [4.74]	42.1 [1.66]	●	●	●				
	DLB-10-N	16	●		236.8 [9.07]	88.6 [3.49]	31.6 [1.24]	●	●					
	DLB-12-N	16	●		249.5 [9.57]	101.2 [3.98]	42.1 [1.66]	●	●	●				
	DLB-16-N	16	●		268.5 [10.32]	120.3 [4.74]	42.1 [1.66]	●	●	●				
	DLB-20-T, A	17	●		315.5 [12.42]	164.6 [6.48]	56.8 [2.24]	●	●	●	●			
	DLB-25-T, A	17	●		351.5 [13.84]	190 [7.48]	56.8 [2.24]	●	●	●	●	●		
	DLB-20-N	18	●		337.3 [13.28]	164.6 [6.48]	56.8 [2.24]	●	●	●	●	●		
	DLB-25-N	18	●		373.3 [14.70]	190 [7.48]	56.8 [2.24]	●	●	●	●	●	●	

LINEAR SLIDES

Sizing and Application Chart

Maximum Stroke mm [in]	Maximum Payload Kg [lbs]	Operating Pressure bar [psi]	Cylinder Type	Bearings	Features
0-50.8 [0-2]	0-10 [0-5]	100 [7]	Internal (Repairable)	Preloaded Ball Bushing	Inductive Sensors
50.8-102 [2-4]	10-25 [5-11]	20-100 [1.4-7]	External (Replaceable)	Composite Bushing	Magneto Resistive Sensors
102-152 [4-6]	25-50 [11-23]	22-100 [1.7-7]	External (Replaceable) with Air Cushions	Roller Bearing	Shock Absorbers
152-203 [6-8]	50-100 [23-45]		External (NFPA/VDMA) Repairable with Air Cushions	Bronze Bushing	Bumpers and Collars
203-254 [8-10]	100-150 [45-68]				Independent End Stops
254-305 [10-12]	150+ [68+]				Telescopic Airlines
305-356 [12-14]					
356-406 [14-16]					
406-457 [16-18]					
457-508 [18-20]					
508-558 [20-22]					
558-610 [22-24]					
610+ [24+]					
Base Slide-Internal Air Cylinder					
0-50.8 [0-2]	0-10 [0-5]	100 [7]	Internal (Repairable)	Preloaded Ball Bushing	Inductive Sensors
50.8-102 [2-4]	10-25 [5-11]	20-100 [1.4-7]	External (Replaceable)	Composite Bushing	Magneto Resistive Sensors
102-152 [4-6]	25-50 [11-23]	22-100 [1.7-7]	External (Replaceable) with Air Cushions	Roller Bearing	Shock Absorbers
152-203 [6-8]	50-100 [23-45]		External (NFPA/VDMA) Repairable with Air Cushions	Bronze Bushing	Bumpers and Collars
203-254 [8-10]	100-150 [45-68]				Independent End Stops
254-305 [10-12]	150+ [68+]				Telescopic Airlines
305-356 [12-14]					
356-406 [14-16]					
406-457 [16-18]					
457-508 [18-20]					
508-558 [20-22]					
558-610 [22-24]					
610+ [24+]					
Base Slide-Internal Air Cylinder-Long Stroke					
0-50.8 [0-2]	0-10 [0-5]	100 [7]	Internal (Repairable)	Preloaded Ball Bushing	Inductive Sensors
50.8-102 [2-4]	10-25 [5-11]	20-100 [1.4-7]	External (Replaceable)	Composite Bushing	Magneto Resistive Sensors
102-152 [4-6]	25-50 [11-23]	22-100 [1.7-7]	External (Replaceable) with Air Cushions	Roller Bearing	Shock Absorbers
152-203 [6-8]	50-100 [23-45]		External (NFPA/VDMA) Repairable with Air Cushions	Bronze Bushing	Bumpers and Collars
203-254 [8-10]	100-150 [45-68]				Independent End Stops
254-305 [10-12]	150+ [68+]				Telescopic Airlines
305-356 [12-14]					
356-406 [14-16]					
406-457 [16-18]					
457-508 [18-20]					
508-558 [20-22]					
558-610 [22-24]					
610+ [24+]					
Linear Thruster Slide-External Air Cylinder					
0-50.8 [0-2]	0-10 [0-5]	100 [7]	Internal (Repairable)	Preloaded Ball Bushing	Inductive Sensors
50.8-102 [2-4]	10-25 [5-11]	20-100 [1.4-7]	External (Replaceable)	Composite Bushing	Magneto Resistive Sensors
102-152 [4-6]	25-50 [11-23]	22-100 [1.7-7]	External (Replaceable) with Air Cushions	Roller Bearing	Shock Absorbers
152-203 [6-8]	50-100 [23-45]		External (NFPA/VDMA) Repairable with Air Cushions	Bronze Bushing	Bumpers and Collars
203-254 [8-10]	100-150 [45-68]				Independent End Stops
254-305 [10-12]	150+ [68+]				Telescopic Airlines
305-356 [12-14]					
356-406 [14-16]					
406-457 [16-18]					
457-508 [18-20]					
508-558 [20-22]					
558-610 [22-24]					
610+ [24+]					

LINEAR SLIDES

Sizing and Application Chart

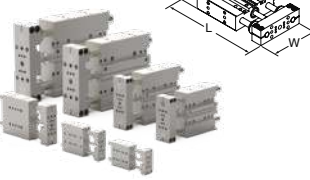
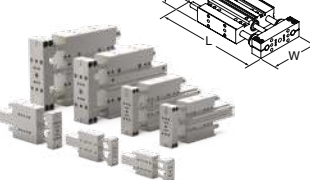
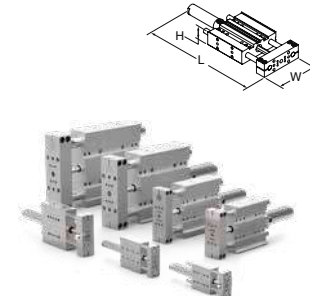
Series	Page #	Slide Type			Basic Unit Dimensions mm [in]			Maximum Thrust Force N [lbs]							
		Base Slide	Thruster Slide	Lift/Block Thruster	Length + Stroke	Width	Height	0-111 [0-25]	111-223 [25-50]	223-445 [50-100]	445-678 [100-150]	678-890 [150-200]	890-1335 [200-300]	1335+ [300+]	
Linear Thruster Slide—Internal Cylinder													GR-LIN-#		
Block Style 	DLT-06M-B	22	●	●	70.7 [2.78]	50.8 [2.00]	22.4 [0.88]	●							
	DLT-08M-B	22	●	●	83.4 [3.28]	63.5 [2.50]	22.4 [0.88]	●							
	DLT-10M-B	25	●	●	122.3 [4.81]	88.9 [3.50]	30.2 [1.19]	●	●						
	DLT-12M-B	25	●	●	135 [5.31]	101.6 [4.00]	41.4 [1.63]	●	●	●					
	DLT-16M-B	25	●	●	155.6 [6.13]	120.7 [4.75]	41.4 [1.63]	●	●	●					
	DLT-20M-B	28	●	●	214.9 [8.46]	165.1 [6.50]	55.9 [2.20]	●	●	●	●				
	DLT-25M-B	28	●	●	245.6 [9.67]	190.5 [7.50]	55.9 [2.20]	●	●	●	●				
Linear Thruster Slide—Internal Cylinder													GR-LIN-#		
Extended Stroke 	DLT-06M-E	23	●		87.5 [3.44]	50.8 [2.00]	22.4 [0.88]	●							
	DLT-08M-E	23	●		93.8 [3.69]	63.5 [2.50]	22.4 [0.88]	●							
	DLT-10M-E	26	●		143.1 [5.63]	88.9 [3.50]	30.2 [1.19]	●	●						
	DLT-12M-E	26	●		155.8 [6.13]	101.6 [4.00]	41.4 [1.63]	●	●	●					
	DLT-16M-E	26	●		174.9 [6.89]	120.7 [4.75]	41.4 [1.63]	●	●	●					
	DLT-20M-E	29	●		239.3 [9.42]	165.1 [6.50]	55.9 [2.20]	●	●	●	●				
	DLT-25M-E	29	●		275.3 [10.84]	190.5 [7.50]	55.9 [2.20]	●	●	●	●				
Linear Thruster Slide—Internal Cylinder													GR-LIN-#		
Long Body 	DLT-06M-L	24	●		115.1 [4.53]	50.8 [2.00]	22.4 [0.88]	●							
	DLT-08M-L	24	●		127.8 [5.03]	63.5 [2.50]	22.4 [0.88]	●							
	DLT-10M-L	27	●		173.1 [6.81]	88.9 [3.50]	30.2 [1.19]	●	●						
	DLT-12M-L	27	●		198.5 [7.81]	101.6 [4.00]	41.4 [1.63]	●	●	●					
	DLT-16M-L	27	●		225.5 [8.88]	120.7 [4.75]	41.4 [1.63]	●	●	●					
	DLT-20M-L	30	●		271.8 [10.70]	165.1 [6.50]	55.9 [2.20]	●	●	●	●				
	DLT-25M-L	30	●		297.2 [11.70]	190.5 [7.50]	55.9 [2.20]	●	●	●	●				
Linear Thruster Slide—External Cylinder													GR-LIN-#		
	DLT-06-T	34	●		125.6 [4.94]	50.8 [2.00]	22.4 [0.88]	●							
	DLT-08-T	34	●		138.3 [5.44]	63.5 [2.50]	22.4 [0.88]	●							
	DLT-10-T, A	35	●		210.3 [8.28]	88.9 [3.50]	30.2 [1.19]	●	●						
	DLT-12-T, A	35	●		226.5 [8.92]	101.6 [4.00]	41.4 [1.63]	●	●	●					
	DLT-16-T, A	35	●		247.1 [9.73]	120.7 [4.75]	41.4 [1.63]	●	●	●					
	DLT-10-N	36	●		209.7 [8.25]	88.9 [3.50]	30.2 [1.19]	●	●						
	DLT-12-N	36	●		222.4 [8.75]	101.6 [4.00]	41.4 [1.63]	●	●	●					
	DLT-16-N	36	●		243.0 [9.57]	120.7 [4.75]	41.4 [1.63]	●	●	●					
	DLT-20-T, A	37	●		322.6 [12.70]	165.1 [6.50]	55.9 [2.20]	●	●	●	●				
	DLT-25-T, A	37	●		353.3 [13.91]	190.5 [7.50]	55.9 [2.20]	●	●	●	●				
	DLT-20-N	38	●		322.6 [12.70]	165.1 [6.50]	55.9 [2.20]	●	●	●	●				
	DLT-25-N	38	●		353.3 [13.91]	190.5 [7.50]	55.9 [2.20]	●	●	●	●				

LINEAR SLIDES

Sizing and Application Chart

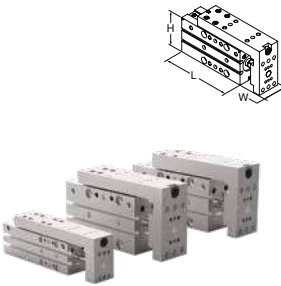
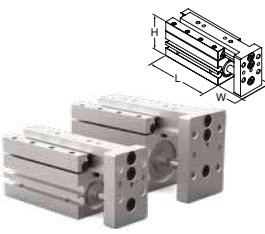
Series	Page #	Slide Type	Basic Unit Dimensions mm [in]			Maximum Thrust Force N [lbs]						
			Length	Width	Height	0-111 [0-25]	111-223 [25-50]	223-445 [50-100]	445-678 [100-150]	678-890 [150-200]	890-1335 [200-300]	1335+ [300+]
Miniature Rail Thruster Slide												
GR-LIN-#												
	DLM-07M-12	43	●	78 [3.07]	21 [0.83]	35.5 [1.40]	●					
	DLM-07M-25	43	●	102 [4.02]	21 [0.83]	35.5 [1.40]	●					
	DLM-07M-38	43	●	115 [4.53]	21 [0.83]	35.5 [1.40]	●					
	DLM-07M-50	43	●	127 [5.00]	21 [0.83]	35.5 [1.40]	●					
	DLM-09M-25	44	●	113 [4.45]	32 [1.26]	62 [2.44]	●	●				
	DLM-09M-50	44	●	159 [6.26]	32 [1.26]	62 [2.44]	●	●				
	DLM-09M-75	44	●	184 [7.24]	32 [1.26]	62 [2.44]	●	●				
	DLM-09M-100	44	●	209 [8.23]	32 [1.26]	62 [2.44]	●	●				
	DLM-12M-50	45	●	122 [4.96]	32 [1.26]	65 [2.56]	●	●	●			
	DLM-12M-75	45	●	166 [6.54]	32 [1.26]	65 [2.56]	●	●	●			
DLM-12M-50	45	●	193 [7.60]	32 [1.26]	65 [2.56]	●	●	●				
DLM-12M-100	45	●	218 [8.58]	32 [1.26]	65 [2.56]	●	●	●				
	MPS-1M-1	49	●	46 [1.81]	20.6 [0.81]	31.8 [1.25]	●					
	MPS-1M-2	49	●	63.4 [2.50]	20.6 [0.81]	31.8 [1.25]	●					
	MPS-1M-3	49	●	88.9 [3.50]	20.6 [0.81]	31.8 [1.25]	●					
	MPS-1M-4	49	●	113 [4.45]	20.6 [0.81]	31.8 [1.25]	●					
	MPS-2M-1	50	●	46 [1.81]	27 [1.06]	39.7 [1.56]	●	●				
	MPS-2M-2	50	●	64.4 [2.54]	27 [1.06]	39.7 [1.56]	●	●				
	MPS-2M-3	50	●	88.9 [3.50]	27 [1.06]	39.7 [1.56]	●	●				
	MPS-2M-4	50	●	113 [4.45]	27 [1.06]	39.7 [1.56]	●	●				

FEED ESCAPEMENTS

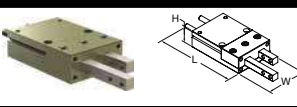
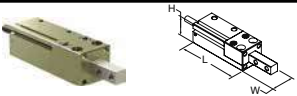
Series	Page #	Shaft	Basic Unit Dimensions mm [in]			Max. Thrust Force N [lbs]	Maximum Stroke mm [in]	Operating Pressure bar [psi]	Cylinder Type	Features				
			Length	Width	Height					Internal (Repairable)	Hall Effect Sensors	Non-rotating Shaft	Fail Safe Locking Fingers	Adjustable Retract
Feed Escapements														
GR-ESC-#														
	RFE-1M	4	●	117 [4.59]	38.1 [1.50]	19.1 [0.75]	●		●	●	✓	✓	✓	✓
	RFE-2M	5	●	162 [6.39]	57.2 [2.25]	24.9 [0.98]	●		●	●	✓	✓	✓	✓
	RFE-3M	6	●	197 [7.74]	69.9 [2.75]	34.5 [1.36]	●		●	●	✓	✓	✓	✓
	RN-1M	8	●	116 [4.59]	22.2 [0.88]	19.1 [0.75]	●		●	●	✓	✓	✓	✓
	RN-2M	9	●	161 [6.34]	28.6 [1.13]	24.9 [0.98]	●		●	●	✓	✓	✓	✓
	RN-2M	10	●	195 [7.70]	34.9 [1.38]	34.5 [1.36]	●		●	●	✓	✓	✓	✓

OEM PRODUCTS

OEM Products | Product Overview

DESTACO's Robohand G110 pneumatic grippers offer affordable gripping solutions that match the price and performance expectations for machine builders and OEM markets.

Engineered to provide better performance, lower maintenance and faster operation, the Robohand OEM solutions deliver high on value for cost sensitive applications.



OEM Pneumatic Parallel Grippers

Model	Stroke mm [in]	Grip Force N [lbf]	Operating Environment	Special Features	Page GR-OEM-#
G110 	5-50 [0.20-1.97]	56-558 [13-125]	IP54, -35° to 80°C [-30° to 180°F]	Extended vertical jaw option (G120). Finger interchangeable with competing models. Wide range of stroke and bore sizes.	3

OEM PRODUCTS

OEM Products | Product Overview

G110 Series - OEM Pneumatic Parallel Grippers

The G110 series family of grippers include 20 model sizes with varying stroke options. An extended jaw option (G120) is offered that is finger compatible with competing products for easier upgrades.

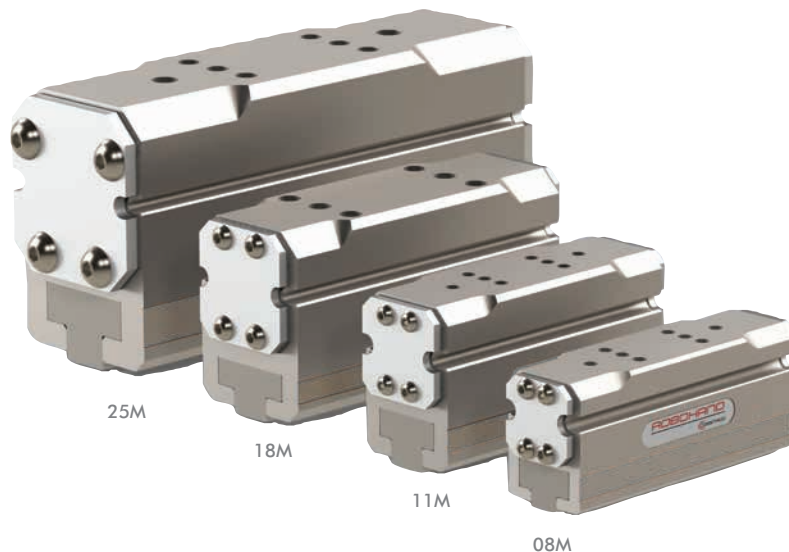

G120 Extended Jaw Option: 100% Finger Compatible



Size	Total Rated Grip Force	Stroke Availability											
		5mm	6mm	10mm	12mm	15mm	18mm	20mm	24mm	25mm	30mm	40mm	50mm
08M	56N [13 lbf]	•		•		•		•		•			
11M	104N [23 lbf]	•		•		•		•		•			
18M	260N [58 lbf]		•		•		•		•		•		
25M	558N [125 lbf]			•				•			•	•	•

G110 SERIES

OEM Parallel Grippers | Features and Benefits | How To Order

Features:

- 20 different models sized to match your application needs
- Fast actuations from 60mS
- Multiple stroke options from 5mm to 50mm
- High grip force, small package from 56N to 558N [13 to 125 lbf]
- Shielded design for clean to moderate manufacturing environments
- Interchangeable gripper fingers with competitive units using extended jaw option
- Locating sleeves for precise finger mounting included with gripper



How To Order

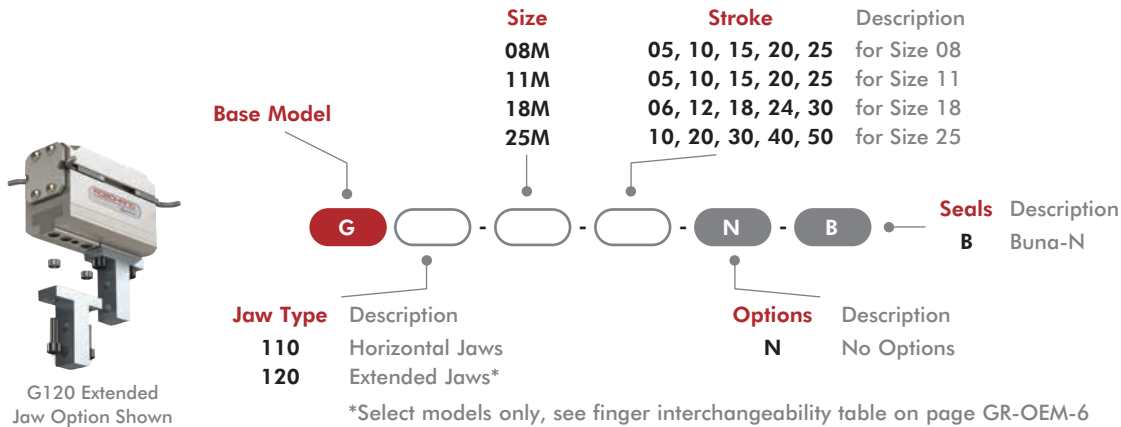

Accessories

G110 Common Accessories	Model Numbers	Part Number	Qty/Unit
Sensor, NPN magneto resistive type, 4mm Barrel	All Models	OHSN-021	1-4
Sensor, PNP magneto resistive type, 4mm Barrel	All Models	OHSP-021	1-4
Cable straight, quick disconnect, socket, 3 conductor, 2M length	All Models	CABL-010	1-4

*Sensor and cable sold separately.



Cable Straight, Quick Disconnect, Socket, 3 Conductor, 2M Length



Long Barrel 4mm Straight Sensor

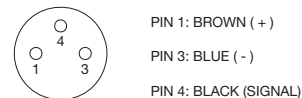
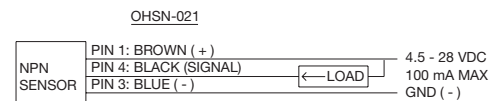
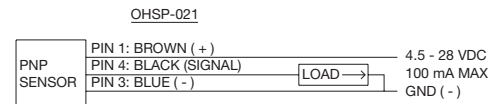

G110 SERIES

OEM Parallel Grippers | Accessories

G110-08M, G120-08M	Part Number	Qty/Unit
Pneumatic air fitting, straight M3 screw to 3mm tube push-in	PLFT-021	2
Jaw locating sleeve for precise finger mounting	20961-11	4
Seal Kit (includes): End gasket G110-08M (Qty 2) Seal: U-cup Buna replacement seal (Qty 4) Button head socket cap screws (Qty 8)	SLKT-244	1
G110-11M, G120-11M	Part Number	Qty/Unit
Pneumatic air fitting, straight M3 screw to 3mm tube push-in	PLFT-021	2
Jaw locating sleeve for precise finger mounting	20961-11	4
Seal Kit (includes): End gasket G110-11M (Qty 2) Seal: U-cup Buna replacement seal (Qty 4) Button head socket cap screws (Qty 8)	SLKT-245	1
G110-18M, G120-18M	Part Number	Qty/Unit
Pneumatic air fitting, right angle, M5 screw to 6mm tube push-in	PLFT-041	2
Valve kit, failsafe, M5 ports	OFSV-004	1
Jaw locating sleeve for precise finger mounting	20962-11	4
Seal Kit (includes): End gasket G110-18M (Qty 2) Seal: U-cup Buna replacement seal (Qty 4) Button head socket cap screws (Qty 8)	SLKT-246	1
G110-25M, G120-25M	Part Number	Qty/Unit
Pneumatic air fitting, right angle, M5 screw to 6mm tube push-in	PLFT-041	2
Valve kit, failsafe, M5 ports	OFSV-004	1
Jaw locating sleeve for precise finger mounting	20963-11	4
Seal Kit (includes): End gasket G110-25M (Qty 2) Seal: U-cup Buna replacement seal (Qty 4) Button head socket cap screws (Qty 8)	SLKT-247	1



Pneumatic Air Fittings



End Gasket



Jaw Locating Sleeve for Precise Finger Mounting



Valve Kit, Failsafe, M5 Ports



U-cup Buna Replacement Seal



Button Head Socket Cap Screws

G110 SERIES

OEM Parallel Grippers | Quick Installation Kits

Commissioning Kits for Easy Ordering

- Includes just what you need for easy installation
- One quick installation kit required per gripper
- Fast, simple convenient ordering



2 Sensors



2 Air Fittings



4 Jaw Locating Finger Sleeves



4 Finger Mounting Screws

G110-08M, G120-08M	Includes	Part Number	Qty/Kit
Sensor, PNP magneto resistive type, 4mm barrel	OHSP-021	G110-QKST-101	2
Pneumatic air fitting, M3 screw to 3mm tube push-in	PLFT-021		2
Jaw locating sleeve for precise finger mounting	20961-11		4
Finger mounting screws	SHSM025C10		4
G110-11M, G120-11M	Includes	Part Number	Qty/Kit
Sensor, PNP magneto resistive type, 4mm barrel	OHSP-021	G110-QKST-102	2
Pneumatic air fitting, M3 screw to 3mm tube push-in	PLFT-021		2
Jaw locating sleeve for precise finger mounting	20961-11		4
Finger mounting screws	SHSM03C10		4
G110-18M, G120-18M	Includes	Part Number	Qty/Kit
Sensor, PNP magneto resistive type, 4mm barrel	OHSP-021	G110-QKST-103	2
Pneumatic air fitting, right angle, M5 screw to 6mm tube push-in	PLFT-041		2
Jaw locating sleeve for precise finger mounting	20962-11		4
Finger mounting screws	SHSM04C12		4
G110-25M, G120-25M	Includes	Part Number	Qty/Kit
Sensor, PNP magneto resistive type, 4mm barrel	OHSP-021	G110-QKST-104	2
Pneumatic air fitting, right angle, M5 screw to 6mm tube push-in	PLFT-041		2
Jaw locating sleeve for precise finger mounting	20963-11		4
Finger mounting screws	SHSM05C16		4

G110 Series Interchangeable Fingers with Extended Gripper Jaw Option. Fast Gripper Commissioning

- Re-use your existing gripper fingers
- Same finger mounting hole pattern as competitive units
- G110 Series Grippers Deliver:
 - Low Maintenance Shielded Design
 - Smooth Rack and Pinion Operation
 - Fast actuations from 60mS
 - Low height profile
 - All-in-one Commissioning Kits

G120 Extended Jaw Option: 100% Finger Compatible

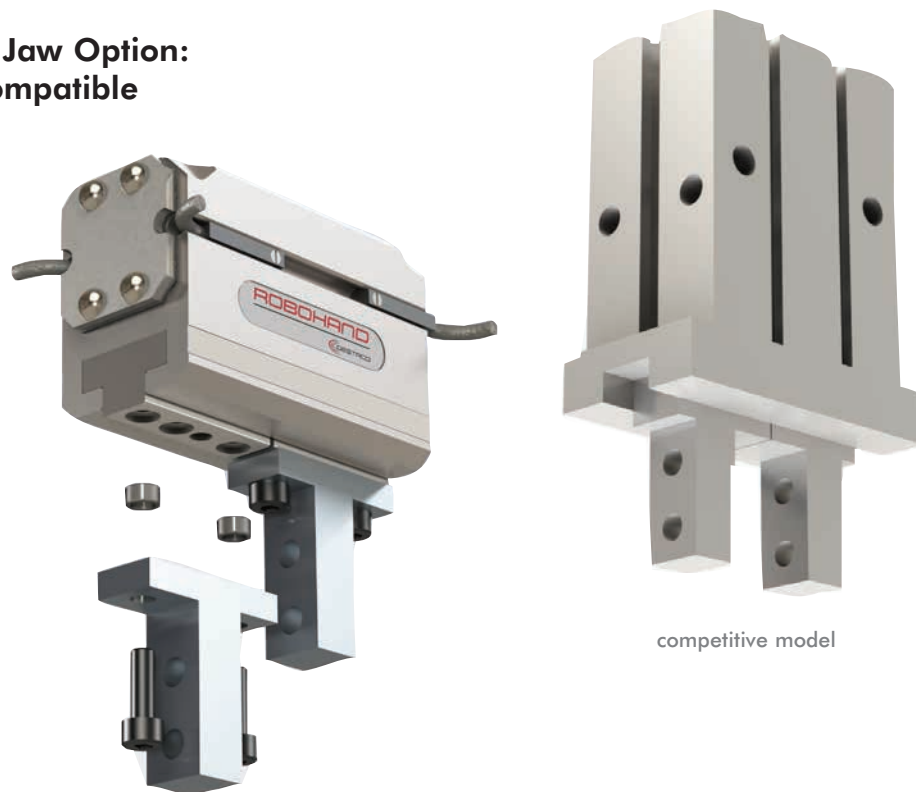

G120 Extended Jaw Option, Finger Interchangeability Table*

(G120 units ship with extended jaw option installed)

Extended Jaw Option Part Number	Mounts to G110 Series Part Number	Compatible with SMC Part Number	Application Notes
G110-FNGR-08M-05	G110-08M-05-N-B	MHZ2-10	G110 has 1mm extra stroke, 9N extra force
G110-FNGR-08M-10	G110-08M-10-N-B	MHZL2-10	G110 has 2mm extra stroke, 10N extra force
G110-FNGR-11M-05	G110-11M-05-N-B	MHZ2-16	G110 has 1mm extra stroke, 13N less force
G110-FNGR-11M-10	G110-11M-10-N-B	MHZL2-16	G110 has 2mm extra stroke, 11N less force
G110-FNGR-18M-12	G110-18M-12-N-B	MHZ2-25	G110 has 2mm extra stroke, 24N extra force
G110-FNGR-18M-24	G110-18M-24-N-B	MHZL2-25	G110 has 2mm extra stroke, 46N extra force
G110-FNGR-25M-20	G110-25M-20-N-B	MHZ2-32	G110 has 2mm extra stroke, 20N less force

*Verify acceptable stroke and force changes in the table above for your application. G120 units are shipped with the extended jaw option mounted from factory. SMC is a registered trademark of SMC Corporation.

G110-08M

OEM Parallel Grippers | Dimensions and Technical Specifications



Specifications	Units	08M
Total Rated Grip Force	N [lbf]	56 [13]
Pressure Range	bar [psi]	3-7 [40-100]
Cylinder Bore Diameter	mm [in]	8 [0.31]
Temperature Range (Buna-N Seals)	°C [°F]	-35°~80° [-30°~180°]
Accuracy	mm [in]	±.05 [0.002]
Repeatability	mm [in]	±.05 [0.002]
Valve Required to Actuate		4 way 2 position

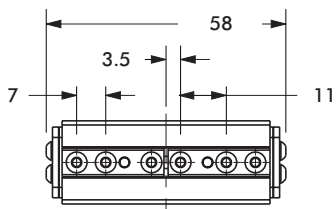
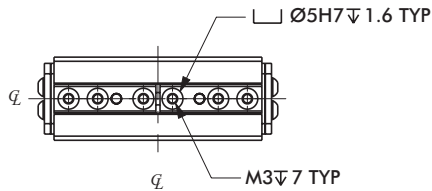
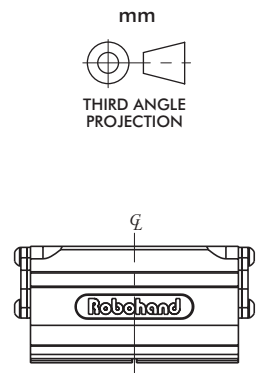
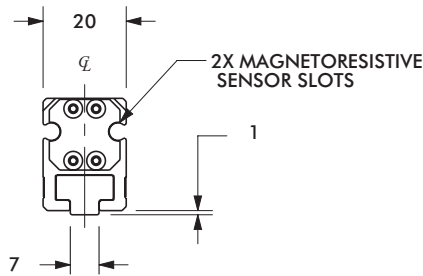
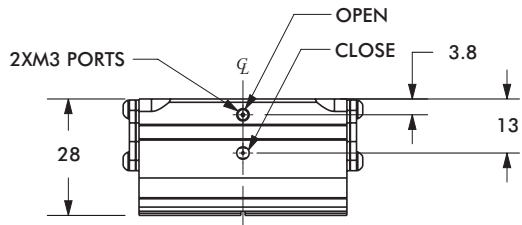
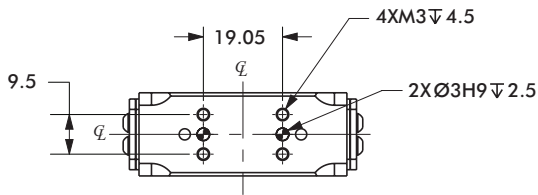

G110-08M-10

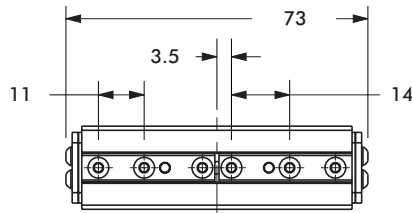

G110-08M-15

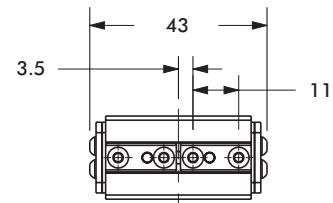

G110-08M-05

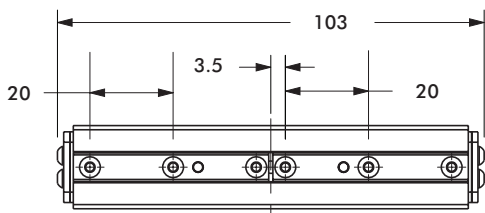

G110-08M-25

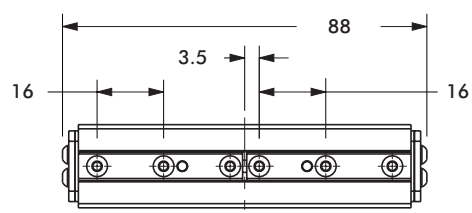

G110-08M-20

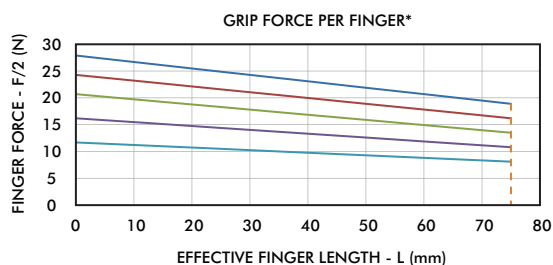
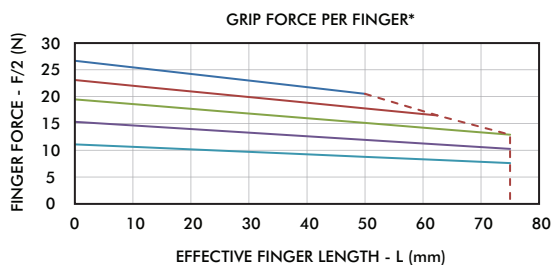
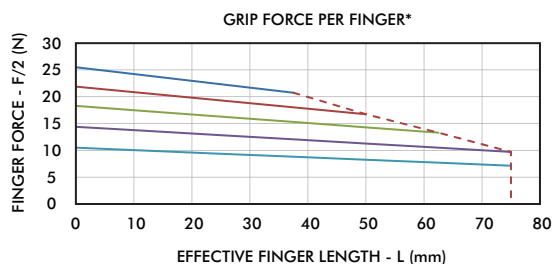
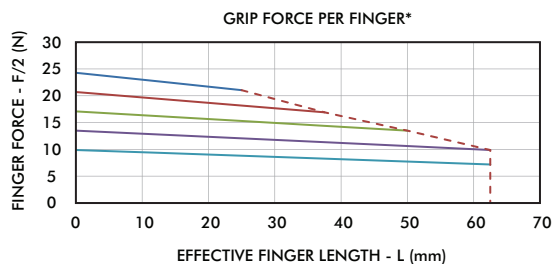
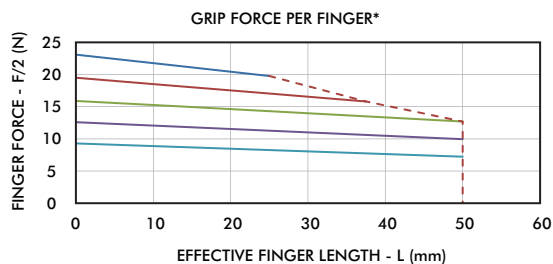

Specifications	Units	08M-05
Stroke	mm [in]	5 [0.20]
Weight	kg [lbs]	0.06 [0.13]
Displacement	cc [cu-in]	0.3 [0.02]
Actuation (open/close)	sec.	0.06
Max Tensile Load on Jaws	N [lbf]	156 [35]
Max Compressive Load on Jaws	N [lbf]	356 [80]
Max Moment on Jaws	Nm [in-lbs]	3.4 [30]

Specifications	Units	08M-10
Stroke	mm [in]	10 [0.39]
Weight	kg [lbs]	0.09 [0.20]
Displacement	cc [cu-in]	0.5 [0.03]
Actuation (open/close)	sec.	0.07
Max Tensile Load on Jaws	N [lbf]	178 [40]
Max Compressive Load on Jaws	N [lbf]	378 [86]
Max Moment on Jaws	Nm [in-lbs]	4 [35]

Specifications	Units	08M-15
Stroke	mm [in]	15 [0.59]
Weight	kg [lbs]	0.11 [0.24]
Displacement	cc [cu-in]	0.7 [0.05]
Actuation (open/close)	sec.	0.08
Max Tensile Load on Jaws	N [lbf]	200 [45]
Max Compressive Load on Jaws	N [lbf]	400 [90]
Max Moment on Jaws	Nm [in-lbs]	4.6 [40]

Specifications	Units	08M-20
Stroke	mm [in]	20 [0.79]
Weight	kg [lbs]	0.14 [0.31]
Displacement	cc [cu-in]	1.0 [0.06]
Actuation (open/close)	sec.	0.09
Max Tensile Load on Jaws	N [lbf]	222 [50]
Max Compressive Load on Jaws	N [lbf]	423 [95]
Max Moment on Jaws	Nm [in-lbs]	5.0 [45]

Specifications	Units	08M-25
Stroke	mm [in]	25 [0.98]
Weight	kg [lbs]	0.17 [0.37]
Displacement	cc [cu-in]	1.2 [0.08]
Actuation (open/close)	sec.	0.10
Max Tensile Load on Jaws	N [lbf]	245 [55]
Max Compressive Load on Jaws	N [lbf]	445 [100]
Max Moment on Jaws	Nm [in-lbs]	5.6 [50]

G110-11M

OEM Parallel Grippers | Dimensions and Technical Specifications

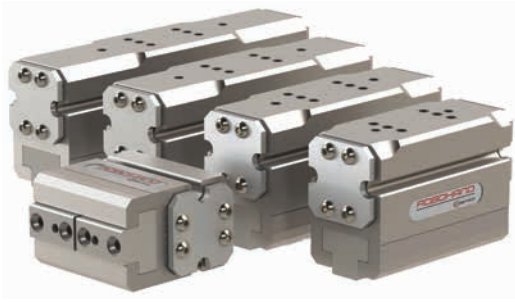

Specifications	Units	11M
Total Rated Grip Force	N [lbf]	104 [23]
Pressure Range	bar [psi]	3-7 [40-100]
Cylinder Bore Diameter	mm [in]	11 [0.44]
Temperature Range (Buna-N Seals)	°C [°F]	-35°~80° [-30°~180°]
Accuracy	mm [in]	±.05 [0.002]
Repeatability	mm [in]	±.05 [0.002]
Valve Required to Actuate		4 way 2 position

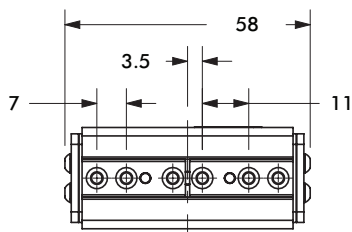
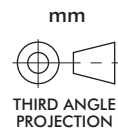
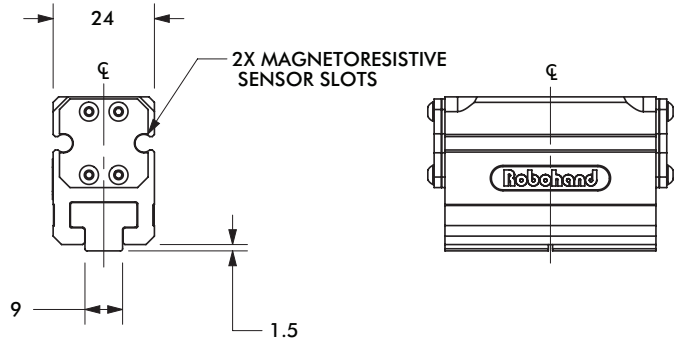
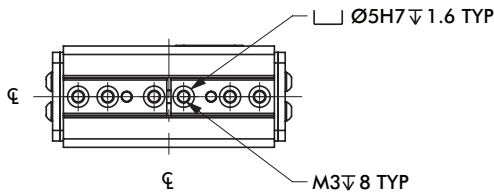
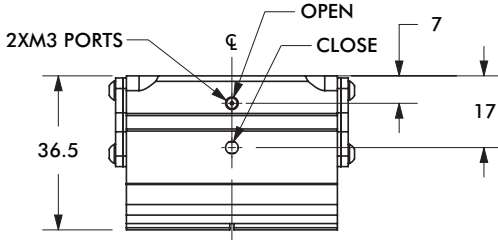
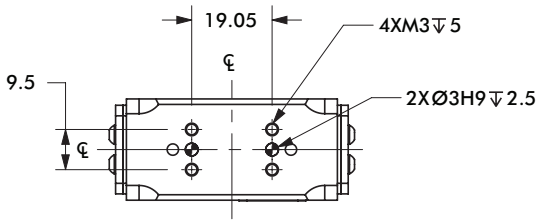

G110-11M-10

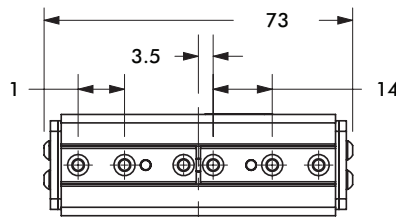

G110-11M-15

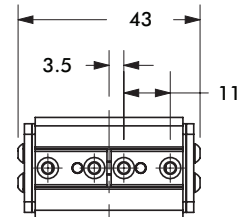

G110-11M-05

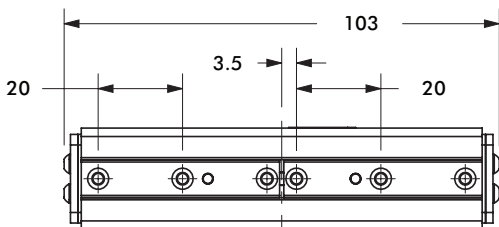

G110-11M-25

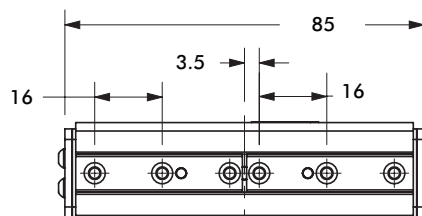

G110-11M-20

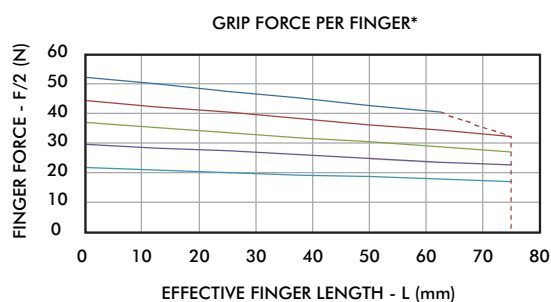
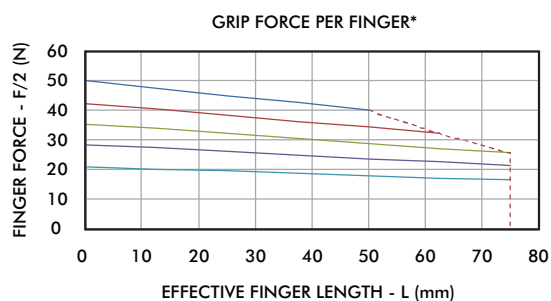
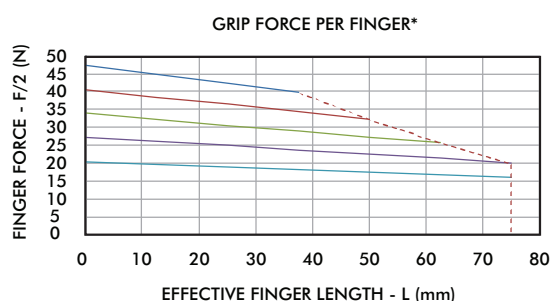
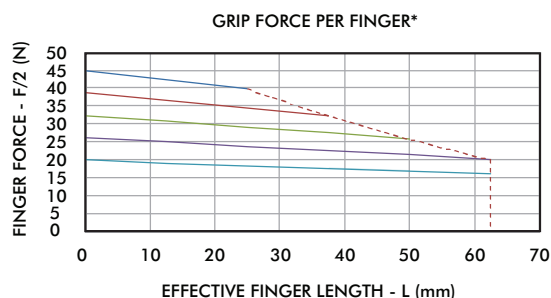
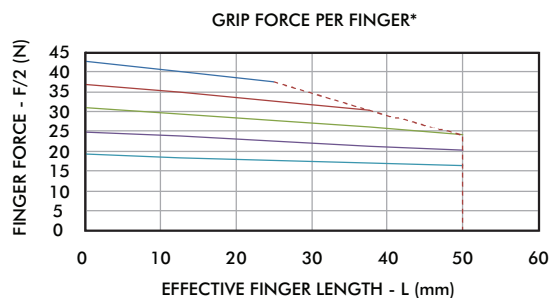

Specifications	Units	11M-05
Stroke	mm [in]	5 [0.20]
Weight	kg [lbs]	0.09 [0.20]
Displacement	cc [cu-in]	0.5 [0.03]
Actuation (open/close)	sec.	0.08
Max Tensile Load on Jaws	N [lbf]	311 [70]
Max Compressive Load on Jaws	N [lbf]	712 [160]
Max Moment on Jaws	Nm [in-lbs]	7 [60]

Specifications	Units	11M-10
Stroke	mm [in]	10 [0.39]
Weight	kg [lbs]	0.13 [0.29]
Displacement	cc [cu-in]	1.0 [0.06]
Actuation (open/close)	sec.	0.09
Max Tensile Load on Jaws	N [lbf]	350 [80]
Max Compressive Load on Jaws	N [lbf]	750 [170]
Max Moment on Jaws	Nm [in-lbs]	8 [70]

Specifications	Units	11M-15
Stroke	mm [in]	15 [0.59]
Weight	kg [lbs]	0.17 [0.37]
Displacement	cc [cu-in]	1.5 [0.09]
Actuation (open/close)	sec.	0.10
Max Tensile Load on Jaws	N [lbf]	400 [90]
Max Compressive Load on Jaws	N [lbf]	800 [180]
Max Moment on Jaws	Nm [in-lbs]	9 [80]

Specifications	Units	11M-20
Stroke	mm [in]	20 [0.79]
Weight	kg [lbs]	0.21 [0.46]
Displacement	cc [cu-in]	1.9 [0.12]
Actuation (open/close)	sec.	0.11
Max Tensile Load on Jaws	N [lbf]	445 [100]
Max Compressive Load on Jaws	N [lbf]	845 [190]
Max Moment on Jaws	Nm [in-lbs]	10 [90]

Specifications	Units	11M-25
Stroke	mm [in]	25 [0.98]
Weight	kg [lbs]	0.25 [0.55]
Displacement	cc [cu-in]	1.2 [0.15]
Actuation (open/close)	sec.	0.12
Max Tensile Load on Jaws	N [lbf]	490 [110]
Max Compressive Load on Jaws	N [lbf]	890 [200]
Max Moment on Jaws	Nm [in-lbs]	11 [100]

G110-18M

OEM Parallel Grippers | Dimensions and Technical Specifications



Specifications	Units	18M
Total Rated Grip Force	N [lbf]	260 [58]
Pressure Range	bar [psi]	3-7 [40-100]
Cylinder Bore Diameter	mm [in]	17.5 [0.69]
Temperature Range (Buna-N Seals)	°C [°F]	-35°~80° [-30°~180°]
Accuracy	mm [in]	±.05 [0.002]
Repeatability	mm [in]	±.05 [0.002]
Valve Required to Actuate		4 way 2 position

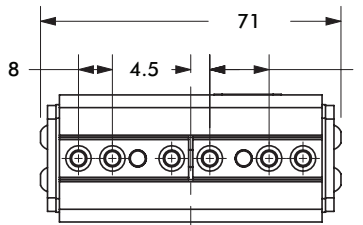
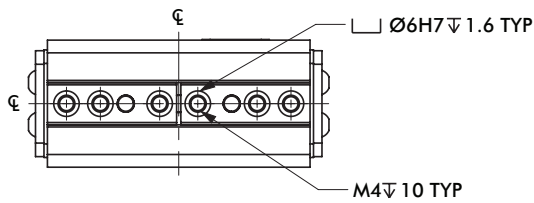
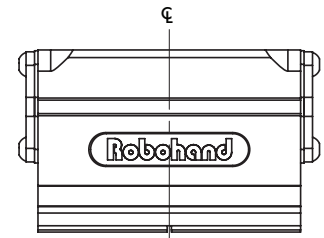
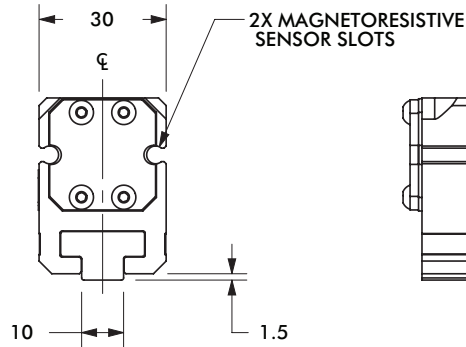
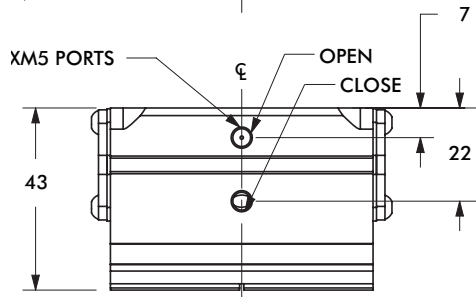
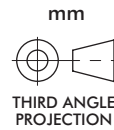
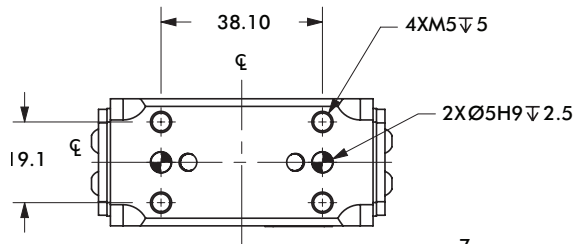

G110-18M-12

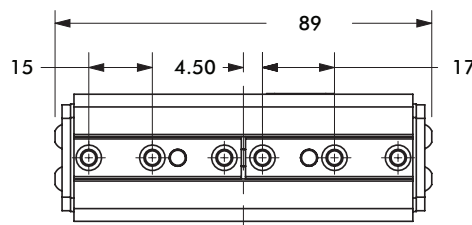

G110-18M-18

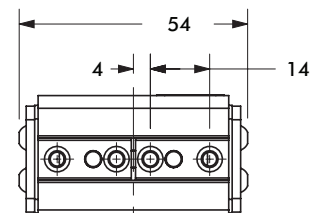

G110-18M-06

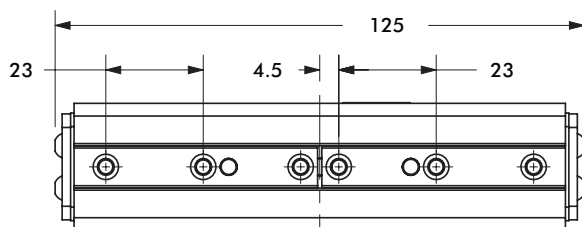

G110-18M-30

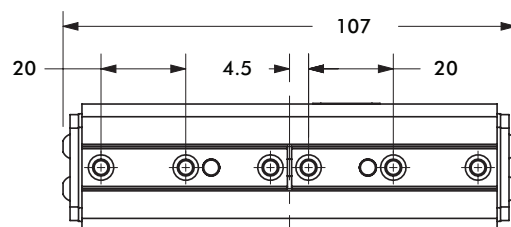

G110-18M-24

OEM Parallel Grippers | Technical Specifications

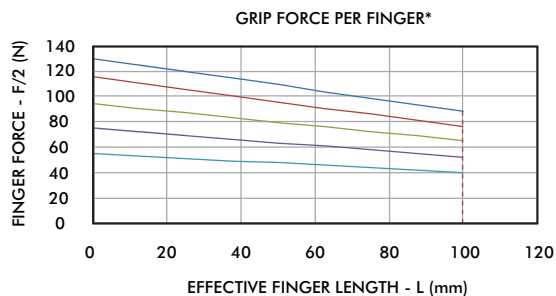
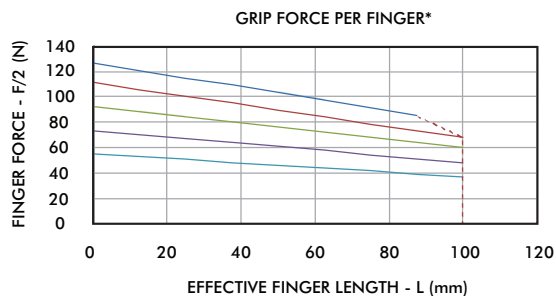
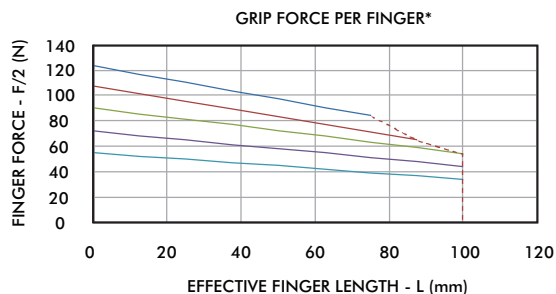
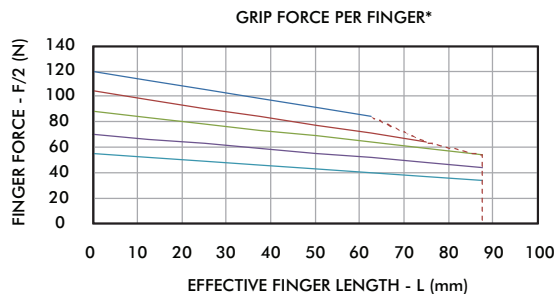
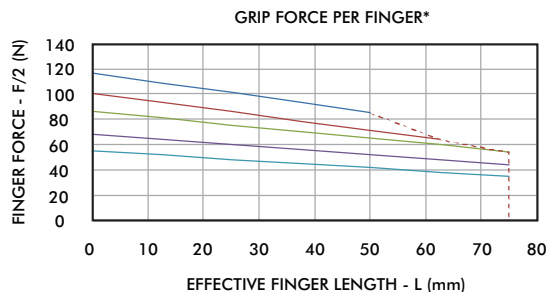

Specifications	Units	18M-06
Stroke	mm [in]	6 [0.24]
Weight	kg [lbs]	0.20 [0.44]
Displacement	cc [cu-in]	1.5 [0.09]
Actuation (open/close)	sec.	0.09
Max Tensile Load on Jaws	N [lbf]	778 [175]
Max Compressive Load on Jaws	N [lbf]	1779 [400]
Max Moment on Jaws	Nm [in-lbs]	17 [150]

Specifications	Units	18M-12
Stroke	mm [in]	12 [0.47]
Weight	kg [lbs]	0.22 [0.48]
Displacement	cc [cu-in]	2.9 [0.18]
Actuation (open/close)	sec.	0.13
Max Tensile Load on Jaws	N [lbf]	890 [200]
Max Compressive Load on Jaws	N [lbf]	1890 [425]
Max Moment on Jaws	Nm [in-lbs]	20 [175]

Specifications	Units	18M-18
Stroke	mm [in]	18 [0.71]
Weight	kg [lbs]	0.28 [0.62]
Displacement	cc [cu-in]	4.3 [0.26]
Actuation (open/close)	sec.	0.17
Max Tensile Load on Jaws	N [lbf]	1000 [225]
Max Compressive Load on Jaws	N [lbf]	2000 [450]
Max Moment on Jaws	Nm [in-lbs]	23 [200]

Specifications	Units	18M-24
Stroke	mm [in]	24 [0.94]
Weight	kg [lbs]	0.34 [0.75]
Displacement	cc [cu-in]	5.8 [0.35]
Actuation (open/close)	sec.	0.21
Max Tensile Load on Jaws	N [lbf]	1112 [250]
Max Compressive Load on Jaws	N [lbf]	2113 [475]
Max Moment on Jaws	Nm [in-lbs]	25 [225]

Specifications	Units	18M-30
Stroke	mm [in]	30 [1.18]
Weight	kg [lbs]	0.41 [0.90]
Displacement	cc [cu-in]	7.2 [0.44]
Actuation (open/close)	sec.	0.25
Max Tensile Load on Jaws	N [lbf]	1223 [275]
Max Compressive Load on Jaws	N [lbf]	2225 [500]
Max Moment on Jaws	Nm [in-lbs]	28 [250]

G110-25M

OEM Parallel Grippers | Dimensions and Technical Specifications



Specifications	Units	25M
Total Rated Grip Force	N [lbf]	558 [125]
Pressure Range	bar [psi]	3-7 [40-100]
Cylinder Bore Diameter	mm [in]	25 [1.00]
Temperature Range (Buna-N Seals)	°C [°F]	-35°~80° [-30°~180°]
Accuracy	mm [in]	±.05 [0.002]
Repeatability	mm [in]	±.05 [0.002]
Valve Required to Actuate		4 way 2 position

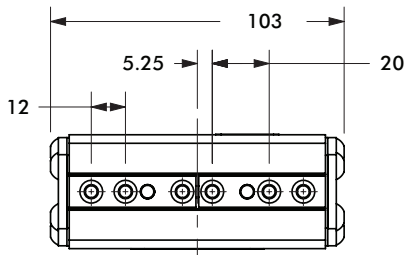
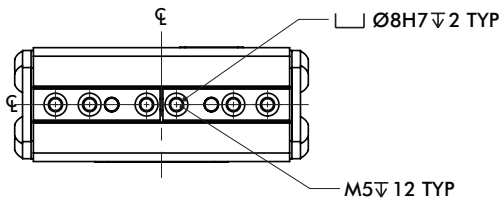
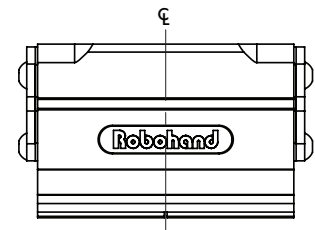
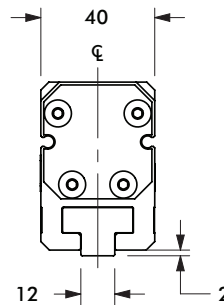
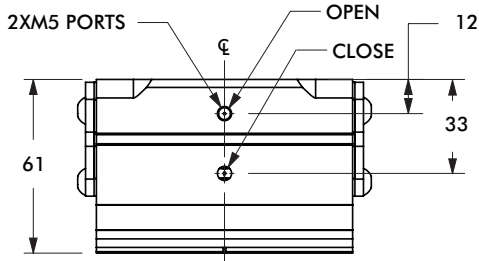
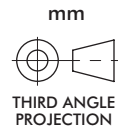
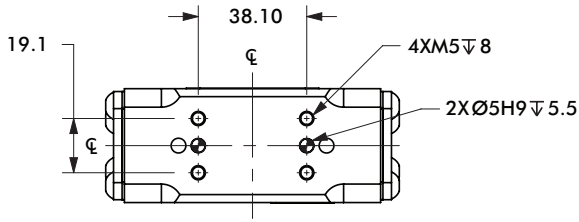

G110-25M-20

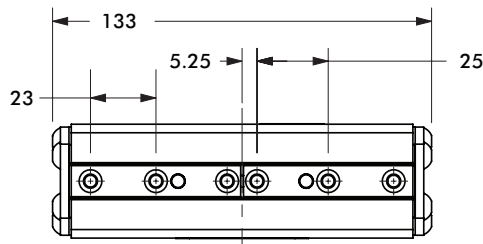

G110-25M-30

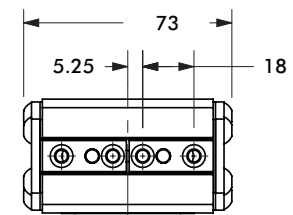

G110-25M-10

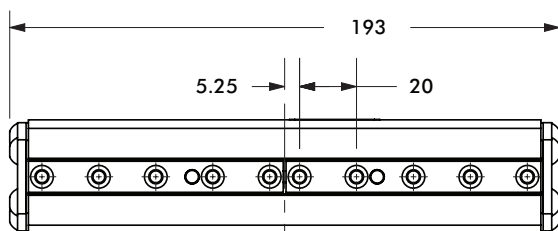

G110-25M-50

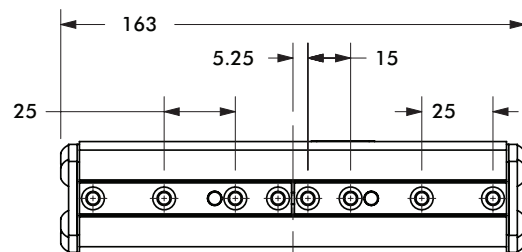

G110-25M-40

OEM Parallel Grippers | Technical Specifications

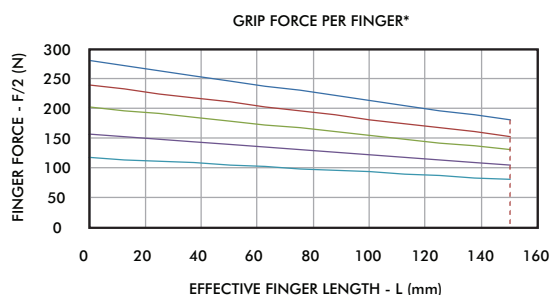
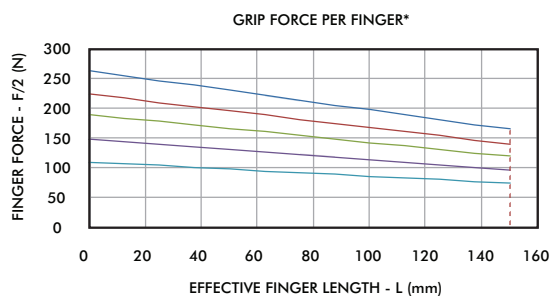
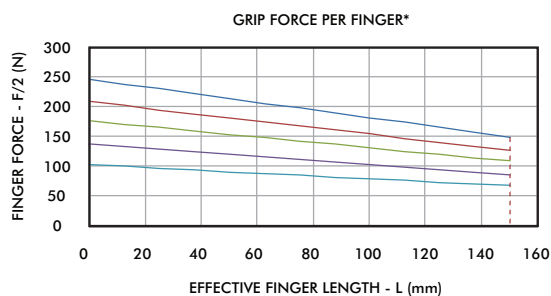
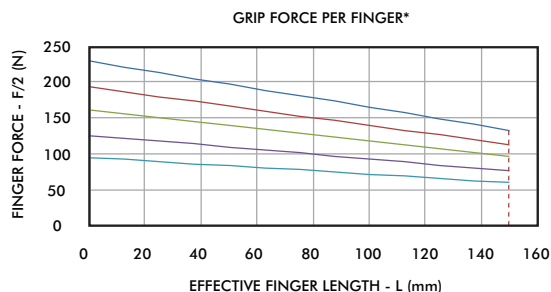
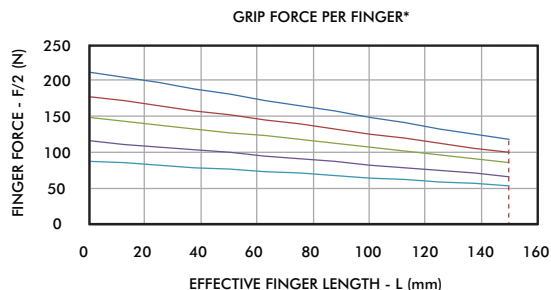

Specifications	Units	25M-10
Stroke	mm [in]	10 [0.39]
Weight	kg [lbs]	0.42 [0.92]
Displacement	cc [cu-in]	5.06 [0.31]
Actuation (open/close)	sec.	0.28
Max Tensile Load on Jaws	N [lbf]	1550 [350]
Max Compressive Load on Jaws	N [lbf]	3550 [800]
Max Moment on Jaws	Nm [in-lbs]	35 [300]

Specifications	Units	25M-20
Stroke	mm [in]	20 [0.79]
Weight	kg [lbs]	0.64 [1.41]
Displacement	cc [cu-in]	10.12 [0.62]
Actuation (open/close)	sec.	0.36
Max Tensile Load on Jaws	N [lbf]	1750 [400]
Max Compressive Load on Jaws	N [lbf]	3775 [850]
Max Moment on Jaws	Nm [in-lbs]	40 [350]



Specifications	Units	25M-30
Stroke	mm [in]	30 [1.18]
Weight	kg [lbs]	0.85 [1.87]
Displacement	cc [cu-in]	15.19 [0.93]
Actuation (open/close)	sec.	0.44
Max Tensile Load on Jaws	N [lbf]	2000 [450]
Max Compressive Load on Jaws	N [lbf]	4000 [900]
Max Moment on Jaws	Nm [in-lbs]	45 [400]

Specifications	Units	25M-40
Stroke	mm [in]	40 [1.57]
Weight	kg [lbs]	1.03 [2.27]
Displacement	cc [cu-in]	20.3 [1.24]
Actuation (open/close)	sec.	0.52
Max Tensile Load on Jaws	N [lbf]	2225 [500]
Max Compressive Load on Jaws	N [lbf]	4225 [950]
Max Moment on Jaws	Nm [in-lbs]	50 [450]

Specifications	Units	25M-50
Stroke	mm [in]	50 [1.97]
Weight	kg [lbs]	1.22 [2.68]
Displacement	cc [cu-in]	25.31 [1.55]
Actuation (open/close)	sec.	0.61
Max Tensile Load on Jaws	N [lbf]	2450 [550]
Max Compressive Load on Jaws	N [lbf]	4450 [1000]
Max Moment on Jaws	Nm [in-lbs]	55 [500]

ELECTRIC PARALLEL GRIPPERS

Electric Parallel Grippers | Product Overview

Model		Stroke mm [in]	Grip Force N [lbs]	Operating Environment	Special Features	Page GR-CRP-#
DPE 400		10-20 [0.39-0.78]	445-1334 [100-300]	IP 50 Clean Room Class 100, ISO 5, General Industrial	Adjustable Force, Discrete on/off open and close control. Onboard controls. DIRECTCONNECT	5
DPE 200		25 [0.98]	111 [25]	IP54 Clean Room Class 1000, ISO 6 General Industrial	Discrete on/off open and close control. Sealed design. Multiple sensor positions. Onboard controls. DIRECTCONNECT	7
RPE		4 [0.16]	5 [1.1]	IP54 Clean Room Class 10, ISO 4 using Scavenge Port, General Industrial	Discrete on/off 50ms pulse open and close control. Small parts handling. High speed.	9

ELECTRIC PARALLEL GRIPPERS

Electric Parallel Grippers | DIRECTCONNECT™ Modular Connectivity Chart

Modular DIRECTCONNECT Mounting Style Examples:

Products can be mounted in multiple positions. Refer to datasheet for complete info.

Slide to Gripper

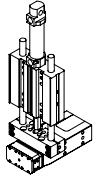

DLT Thruster Slide to DPE-200 Electric Gripper

Slide to Gripper

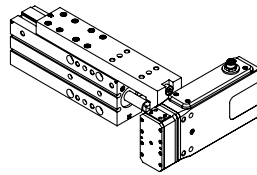

DLM Thruster Slide to DPE-200 Electric Gripper

Slide to Gripper

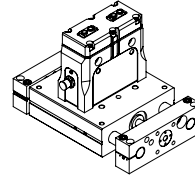

DLB Base Slide to DPE-400 Electric Gripper

Slide to Gripper

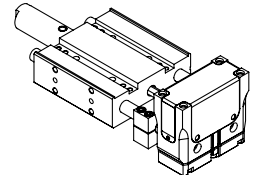

DLT Thruster Slide to DPE-400 Electric Gripper

DIRECTCONNECT™

Mounting Compatibility Chart

DESTACO's DIRECTCONNECT™ technology, allows all components of the system—grippers and slides—to be mounted together directly. Look for matching icons on product datasheets for mounting compatibility.

Note: The numbers in the cell represent the metric screw size and basic mounting pattern.

S=Square, R=Rectangle. ie; 5S = M5 Screw with square mounting pattern.

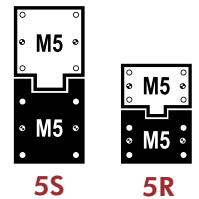

Catalog Models		2 Jaw Electric Parallel Grippers	
		DPE-200	DPE-400
Base Slides	DLB-06,08		
	DLB-10,12,16	5R	
	DLB-20,25		10R
Thruster Slides	DLT-06,08		
	DLT-10,12,16	5R	
	DLT-20,25	5R	10R
	DLM-07		
	DLM-9,12	5R	

E-GRIPPER SERIES

Electric Parallel Grippers | Features and Benefits

Plug-and-Play e-Grippers

Quick Installation

Unit installs quickly using one cable for both power and operation. DIRECTCONNECT™ feature on DPE units allows mounting to rotaries and slides without adapter plates.

Light Switch Operation

No tuning or programming required. Grippers use discrete PLC outputs to control open and close operation. Grippers are powered by 24VDC.

Zero Maintenance

Zero maintenance required for standard environments. Units are internally lubricated and sealed. No air lines, valves, tubing, filters or compressor to interfere with high reliable operations.

100% Duty Cycle Operation for Durability

DPE Series supports continuous open/close command signal operation. Tight mechanical tolerances minimize wear leading to high life cycle operations.



RPE 100
5N [1 lbf]

DPE 200
111N [25 lbf]

DPE 400
1334 N [300 lbf]

DESTACO vs. Others

Features	DESTACO Light Switch Operation	Competing Units
Direct Mechanical Drive ¹	<input checked="" type="checkbox"/>	
Integrated Motor Controls ²	<input checked="" type="checkbox"/>	
Zero Maintenance ³	<input checked="" type="checkbox"/>	
DIRECTCONNECT™ ⁴	<input checked="" type="checkbox"/>	
Programming Software ⁵		<input checked="" type="checkbox"/>
Clean Room Certified	<input checked="" type="checkbox"/>	<input checked="" type="checkbox"/>
Zero Backlash/Side Play	<input checked="" type="checkbox"/>	

- DESTACO uses a direct mechanical linkage to drive the jaws and eliminate finger play, as opposed to a belt drive design.
- Integrated electronics decreases cabling and space requirements, while increasing overall system integrity.
- Competing units recommend lubrication maintenance intervals.
- DIRECTCONNECT™ allows units to be mounted to rotaries or slides without adapter plates.
- Light Switch operation products require no software.

E-GRIPPER SERIES

Electric Parallel Grippers | Compare the eGripper Series

Features	DPE-400	DPE-200	RPE-100
Grip Force Range	445-1334N [100-300 lbf]	111N [25 lbf]	5N [1.1 lbf]
Stroke Range	10mm [0.39 in] or 20mm [0.78 in]	25mm [0.98 in]	4mm [0.16 in]
Actuation (open/close)	800 ms	250 ms	100 ms
Accuracy	±0.05mm [0.002 in]	±0.05mm [0.002 in]	±0.05mm [0.002 in]
Jaw Drive Mechanism	Lead Screw/Wedge	Rack-and-Pinion	Solenoid Plunger
Adjustable Grip Force	<input checked="" type="checkbox"/>		
100% Duty Cycle	<input checked="" type="checkbox"/>	<input checked="" type="checkbox"/>	
DIRECTCONNECT™ Feature	<input checked="" type="checkbox"/>	<input checked="" type="checkbox"/>	
FailSafe Operation			<input checked="" type="checkbox"/>
Internal Sensing	<input checked="" type="checkbox"/>		
IP Rating	IP50	IP54	IP54

Clean Room Rated:

DESTACO's electric products are ideal for food, medical and clean room applications. Electric products are internally lubricated and sealed, per the chart below:

Clean Room Rating	DPE-400	DPE-200	RPE-100
	100	1000	100
Lubricant	Magnalube	Krytox	Krytox

Contact DESTACO for a full range of clean room certified products at solutions@destaco.com

DPE-400 HEAVY-DUTY

Electric Parallel Grippers | Features and Benefits | Technical Specifications

Features:

- Two stroke ranges from 0 to 10mm and 0 to 20mm
- Grip Force adjust-ability from 100% to 50% controlled from the 0 to 5VDC analog input
- Fully integrated electronics, no programming or software Operates from PLC discrete open/close commands
- Reverse polarity protection to protect from application mis-wiring
- DIRECTCONNECT™ mounting to rotaries and slides without requiring adapter plates
- Open and close sensing via built-in motor feedback signal
- Clean room 100 rated



How To Order

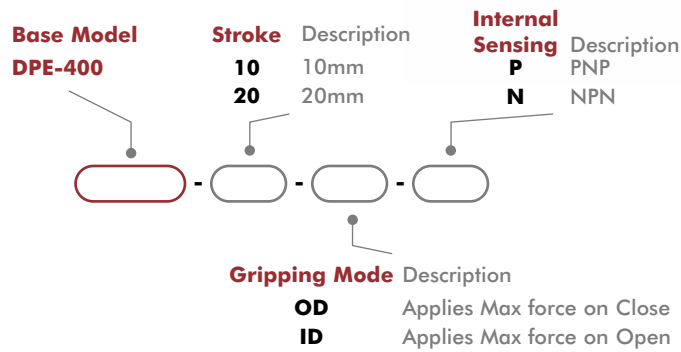

OD (Outside Diameter)



ID (Inside Diameter)

Accessories

Power and Sensor Accessories	Part Number
PNP Magneto-Resistive Position Sensor	OHSP-017
NPN Magneto-Resistive Position Sensor	OHSN-017
Quick Disconnect Sensor Cable, 5m long	CABL-013
8-wire Power and Signal Cable, 5m long with Straight M12 Connector	CABL-052
8-wire Power and Signal Cable, 5m long with 90° M12 Connector	CABL-053

*Sensor and cable sold separately.

Electrical Interface: Pin Out

(Looking into the head of the connector on gripper)

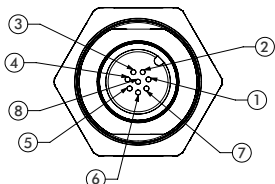

Voltage shown is applied to the FORCE pin, which accepts a 0-5V analog signal.

Pin #	Color	Signal	Description	Current
1	White	Force	0-5 VDC (Analog)	5mA
2	Brown	+24V	Motor Power	2A (max), 0.4 A (avg)
3	Green	Open	24 VDC Active (Inputs)	10mA
4	Yellow	Open Sense	NPN/PNP (Outputs)	300mA (max)
5	Gray	Close	24 VDC Active (Inputs)	10mA
6	Pink	Close Sense	NPN/PNP (Outputs)	300mA (max)
7	Blue	Ground	Motor Ground	2A (max),
8	Red	I/O Power	24 VDC (PNP Outputs Only)	300mA (max)

Electric Parallel Grippers | Dimensions and Technical Specifications

Specifications	Units	DPE-400
Total Rated Grip Force:		
DPE-400-10	N [lbf]	667-1334 [150-300]
DPE-400-20	N [lbf]	445-890 [100-200]
Total Stroke:		
DPE-400-10	mm [in]	10 [0.39]
DPE-400-20	mm [in]	20 [0.78]
Repeatability	mm [in]	±0.025 [0.001]
Accuracy	mm [in]	±0.05 [0.002]
Actuation Time	ms	800
Temperature Range	°C [°F]	0~55° [32°~131°]
Power Requirements @ 100% Duty Cycle	watts	10
Voltage	VDC	24
DC Current (Peak)	amps	2 (max)
DC Current: (Continuous)	amps	0.4
Ingress Protection Class (IP)		IP50
Clean Room		100 (MagnaLube)
Weight	kg [lbs]	2.52 [5.56]
Maximum Finger Length	mm [in]	125 [4.92]
Durability	cycles	3 Million



Shown with customer supplied fingers.

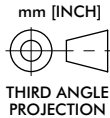
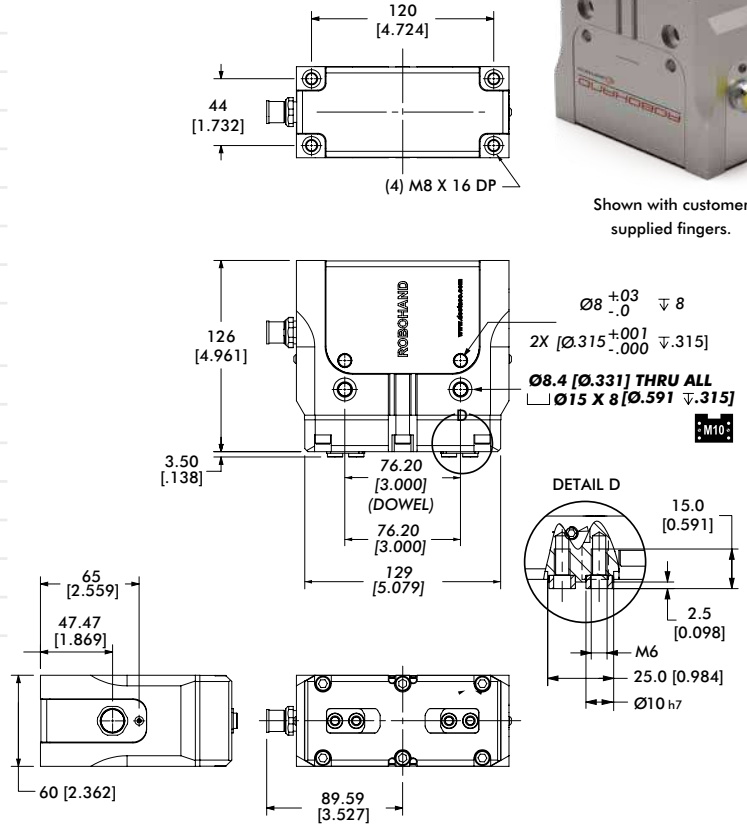

NOTE: REVERSE POLARITY PROTECTED

Loading Information

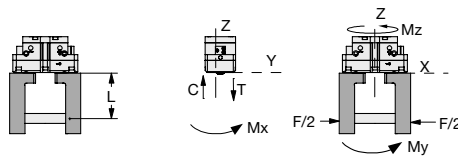
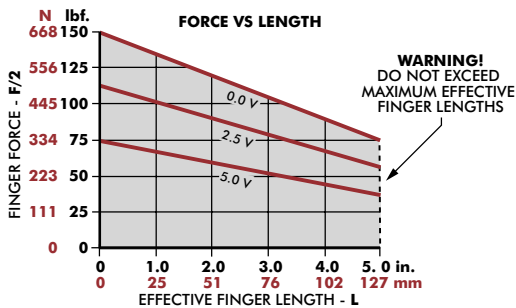

DPE-400-10	Static	Dynamic
Maximum Tensile T	1564 N [352 lbs]	259 N [58 lbs]
Maximum Compressive C	2070 N [465 lbs]	259 N [58 lbs]
Maximum Moment M_x	76 Nm [673 in-lbs]	10 Nm [89 in-lbs]
Maximum Moment M_y	106 Nm [938 in-lbs]	14 Nm [124 in-lbs]
Maximum Moment M_z	70 Nm [620 in-lbs]	14 Nm [124 in-lbs]

¹Capacities are per set of jaws and are not simultaneous

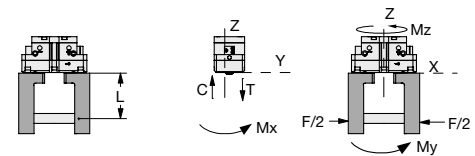
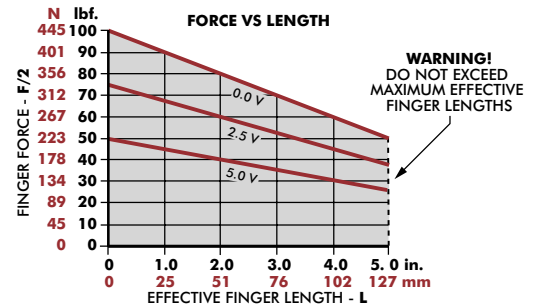

DPE-400-20	Static	Dynamic
Maximum Tensile T	1394 N [313 lbs]	168 N [38 lbs]
Maximum Compressive C	1845 N [415 lbs]	168 N [38 lbs]
Maximum Moment M_x	68 Nm [602 in-lbs]	6 Nm [53 in-lbs]
Maximum Moment M_y	84 Nm [743 in-lbs]	8 Nm [71 in-lbs]
Maximum Moment M_z	56 Nm [496 in-lbs]	8 Nm [71 in-lbs]

¹Capacities are per set of jaws and are not simultaneous

DPE-200 MEDIUM-DUTY

Electric Parallel Grippers | Features and Benefits | How To Order

Features:

- Ideal for semiconductor and life sciences laboratory applications
- Fast parts handling with grip speeds capable of 120 parts per minute with a 25mm stroke and 250ms actuation time
- High reliability up to four times longer than pneumatic equivalents
- Maintenance free internally lubricated and sealed
- Precision rack-and-pinion drive helps to maintain grip accuracy of +/- 0.05mm (0.002in)
- Fully integrated electronics, no programming or software. Operates from PLC discrete open/close commands
- Reverse polarity protection to protect from application mis-wiring
- DIRECTCONNECT™ mounting to rotaries and slides without requiring adapter plates
- Clean room 1000 rated

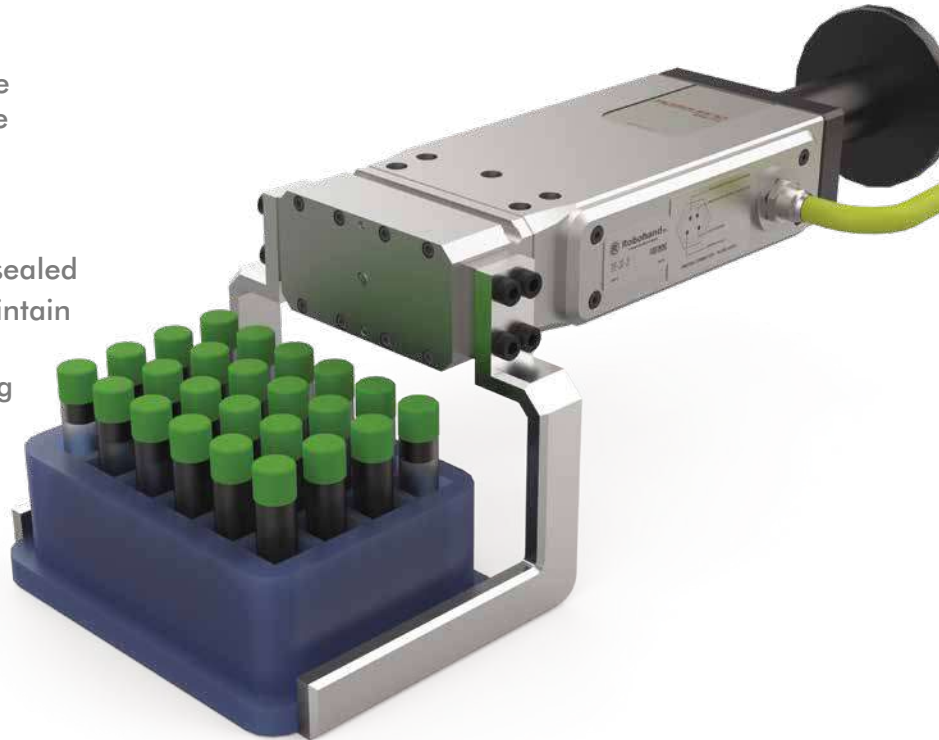

How To Order

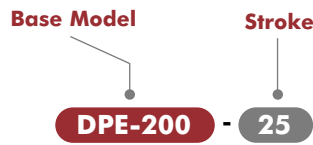

Accessories

Power and Sensor Accessories	Part Number
PNP Magneto-Resistive Position Sensor	OHSP-017
NPN Magneto-Resistive Position Sensor	OHSN-017
Quick Disconnect Sensor Cable, 5m Long	CABL-013
4-wire Power and Signal Cable, 5m Long	CABL-046

*Sensor and cable sold separately.

Electrical Interface: Pin Out

(Looking into the head of the connector on gripper)

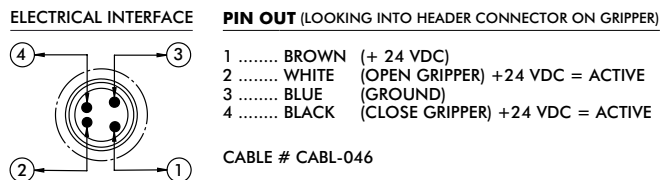

Electric Parallel Grippers | Dimensions and Technical Specifications



Shown with customer supplied fingers.

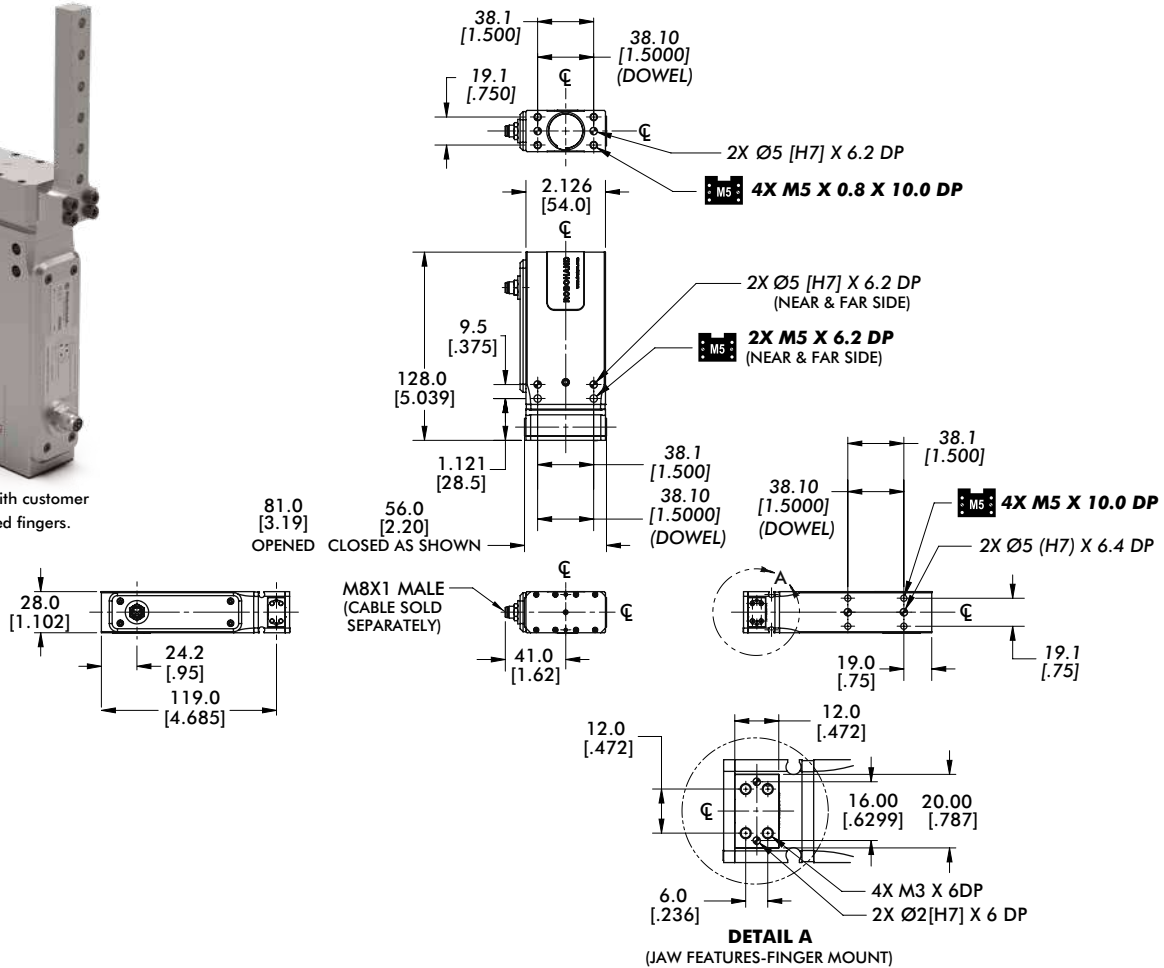

Specifications

Specifications	Units	DPE-200-25
Total Grip Force	N [lbf]	111 [25]
Stroke	mm [in]	25 [0.98]
Repeatability	mm [in]	±0.025 [0.001]
Accuracy	mm [in]	±0.051 [0.002]
Actuation Time	ms	250
Temperature Range	°C [°F]	5°~60° [41°~140°]
Power Requirement @ 100% duty cycle	W	4.2
Voltage	VDC	24
Current - Peak	amps	1.5 (max)
Current - Continuous	amps	0.175
Ingress Protection Class (IP)		IP54
Clean Room		1000 (Krytox)
Weight	kg [lbs]	0.53 [1.16]
Max Finger Length	mm [in]	76.2 [3.00]
Durability	cycles	20 Million

Loading Information

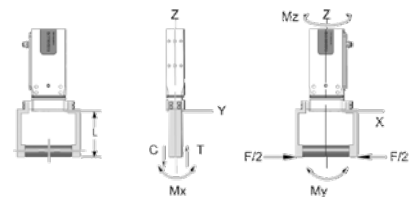
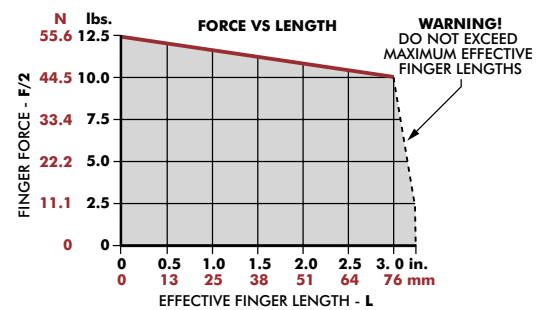

DPE-200-25	Static
Maximum Tensile T	10 N [75 lbs]
Maximum Compressive C	10 N [75 lbs]
Maximum Moment M_x	14 Nm [120 in-lbs]
Maximum Moment M_y	17 Nm [150 in-lbs]
Maximum Moment M_z	14 Nm [120 in-lbs]

*Capacities are per set of jaws and are not simultaneous

RPE-100 LIGHT-DUTY

Electric Parallel Grippers | Features and Benefits | How To Order

Features:

- Ideal for semiconductor and life sciences laboratory applications
- Compact design allows several units mounted closely together to grip multiple parts simultaneously
- Fully integrated electronics, no programming or software. Operates from PLC discrete open/close commands
- Fail-safe operation with spring closed maintains full grip force upon power loss
- No programming required. Gripper actuates using a 50ms discrete pulse from PLC or controller
- Minimized finger backlash and side play with low friction Dual-V bearing system
- Maintenance free internally lubricated and sealed
- Clean room 100 rated IP54

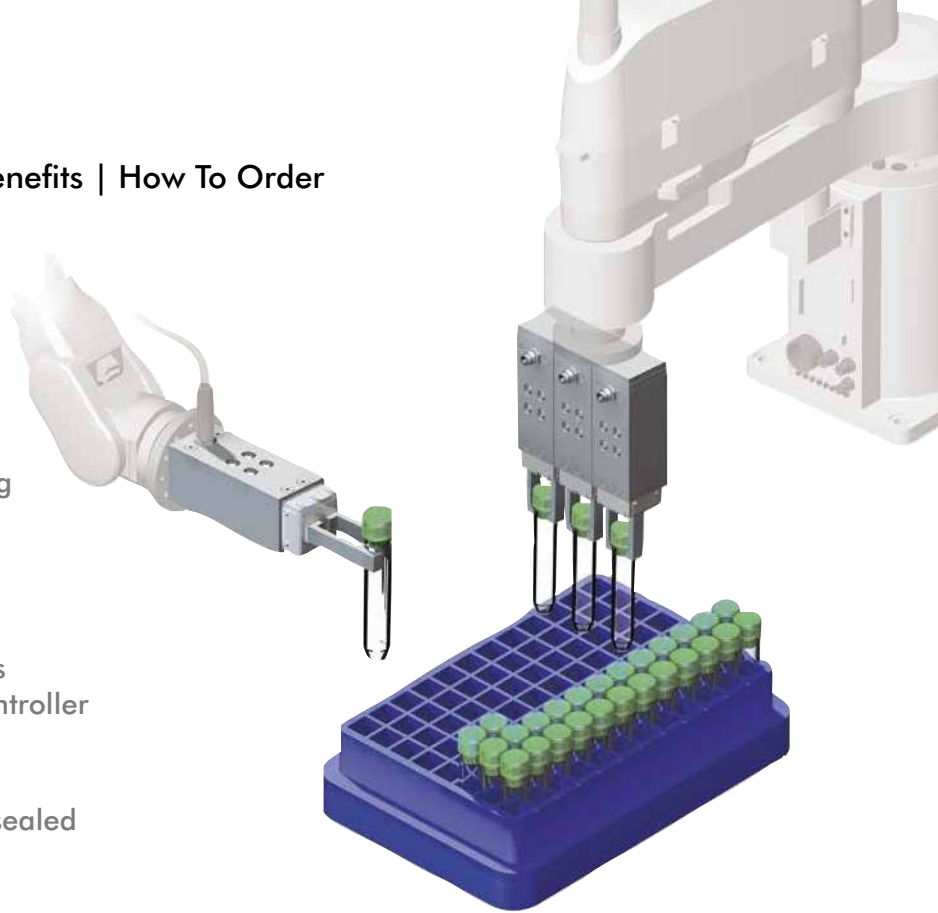

How To Order

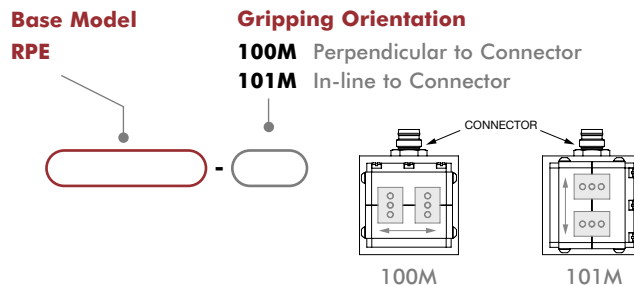

Accessories

Sensor Accessories	Part Number
Inductive Sensor Mounting Kit (Mounts 1 sensor)	OSMK-130
PNP Inductive Sensor with Quick Connect	OISP-019
NPN Inductive Sensor with Quick Connect	OISN-019
Quick Disconnect Sensor Cable, 2m long	CABL-010
Quick Disconnect Sensor Cable, 5m long	CABL-013

*Sensor and cable sold separately.

Electrical Interface: Pin Out

(Looking into the head of the connector on gripper)

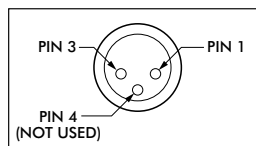

PIN ORIENTATION

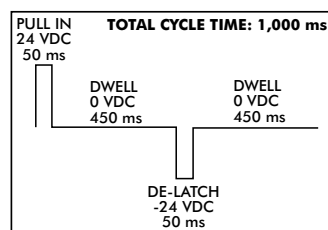

TIMING DIAGRAM

RPE-100 LIGHT-DUTY

Electric Parallel Grippers | Dimensions and Technical Specifications

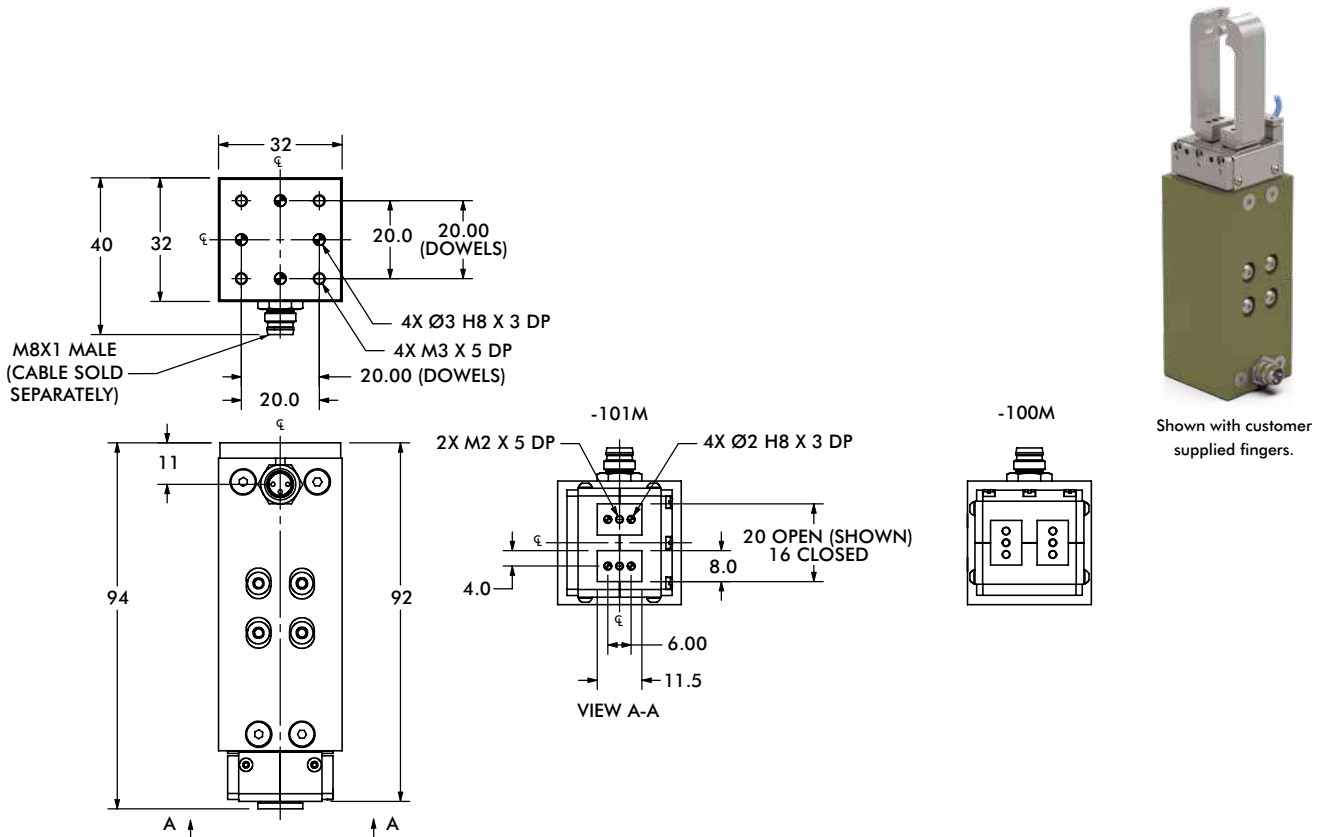

Specifications

Specifications	Units	RPE-100M/101M
Total Grip Force	N [lbf]	5 [1.1]
Stroke	mm [in]	4 [0.16]
Repeatability	mm [in]	±0.025 [0.001]
Accuracy	mm [in]	±0.051 [0.002]
Actuation Time	ms	100
Temperature Range	°C [°F]	5°~50° [40°~120°]
Power Requirement @ 100% duty cycle	W	40 (Peak)
Voltage	VDC	24
Current - Peak	amps	1.5 (max)
Current - Continuous	amps	0.175
Ingress Protection Class (IP)		IP54
Clean Room		100 (Krytox)
Weight	kg [lbs]	0.23 [0.50]
Max Finger Length	mm [in]	50 [1.90]
Durability	cycles	5 Million

Loading Information

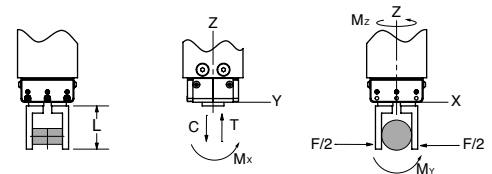
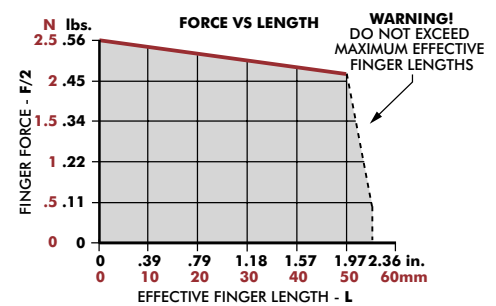

RPE-100, RPE-101	Static	Dynamic
Maximum Tensile T	59 N [13 lbs]	20 N [4.5 lbs]
Maximum Compressive C	59 N [13 lbs]	20 N [4.5 lbs]
Maximum Moment M_x	0.75 Nm [2.7 lbf-in]	0.3 Nm [6.6 lbf-in]
Maximum Moment M_y	1.2 Nm [10.6 lbf-in]	0.4 Nm [3.5 lbf-in]
Maximum Moment M_z	0.75 Nm [6.6 lbf-in]	1.1 Nm [9.7 lbf-in]

^tCapacities are per set of jaws and are not simultaneous

PRECISION PARALLEL GRIPPERS

2-Jaw Parallel Grippers | Product Overview

Model	Stroke mm [in]	Grip Force N [lbs]	Operating Environment	Special Features	Page #	
2P		10-50 [0.39-1.97]	432-11,475 [97-2579]	IP 54	Spring assist. Double force tandem cylinder option. Large choice of configurable options.	3
DGC		20-40 [0.79-1.57]	474-796 [106-179]	IP54 Using Purge Port	Rugged applications. Spring assist. DIRECTCONNECT	15
GC		50-60 [1.968-2.362]	1481-2318 [333-521]	IP54 Using Scavenge Port	Rugged applications. Spring assist.	15
DPL		40-140 [1.575-5.512]	618-2035 [138- 457]	IP54 Using Purge Port	Longest strokes in compact length. Long finger lengths. DIRECTCONNECT	23
DPP		6.35-50.8 [0.25-2]	111-934 [25-210]	IP43 Using Purge Port. Clean Room Class 10,000 ISO 7 Using Scavenge Port	Highest precision, low pressure applications. Zero side play with Dual-V bearing design. DIRECTCONNECT	33
RP-P		12.7-76.2 [0.5-3.0]	107-2224 [24-500]	IP33	Highest precision. Long finger lengths. Delicate parts handling.	39
RPL		6.4 -25.4 [0.25-1.0]	116-160 [26-36]	IP33	Low pressure applications, zero side play, Excellent repeatability, long finger lengths. Delicate parts Handling.	47
RPLC		6.4-25.4 [0.25-1.0]	116-160 [26-36]	IP64 Using Purge Port. Clean Room Class 10, ISO 4 Using Scavenge Port	Shielded for Clean or Harsh Environments. Low Pressure Applications, Zero Side Play. Excellent Repeatability	47

PRECISION PARALLEL GRIPPERS

2-Jaw Parallel Grippers | DIRECTCONNECT™ Modular Connectivity Chart

Modular DIRECTCONNECT Mounting Style Examples:

Products can be mounted in multiple positions. Refer to datasheet for complete info.

Slide to Gripper

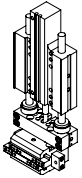

DLT Thruster Slide to DGC Parallel Gripper

Slide to Gripper

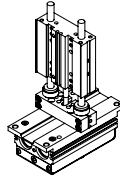

DLT Thruster Slide to DPL Parallel Gripper

Slide to Gripper

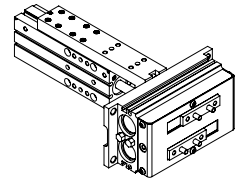

DLM Thruster Slide to DPL Parallel Gripper

Slide to Gripper

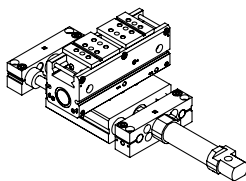

DLB Base Slide to DPP Parallel Gripper

Slide to Gripper

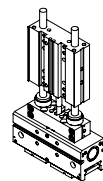

DLT Thruster Slide to DPP Parallel Gripper

Slide to Gripper

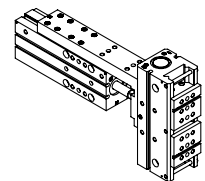

DLM Thruster Slide to DPP Parallel Gripper

DIRECTCONNECT™

Mounting Compatibility Chart

DESTACO's DIRECTCONNECT™ technology, allows all components of the system—grippers and slides—to be mounted together directly. Look for matching icons on product datasheets for mounting compatibility.

Note: The numbers in the cell represent the metric screw size and basic mounting pattern.

S=Square, R=Rectangle. ie; 5S = M5 Screw with square mounting pattern.

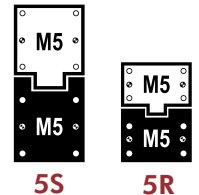

Catalog Models		2 Jaw Precision Parallel Grippers					
		DGC	DPL-25XX	DPL-32XX, 40XX	DPP-10 & 14	DPP-20	DPP-28
Base Slides	DLB-06,08				3R		
	DLB-10,12,16	5R	5R			5R	5R
	DLB-20,25			10R			10R
Thruster Slides	DLT-06,08				3R		
	DLT-10,12,16	5R	5R		3R	5R	5R
	DLT-20,25	5R	5R	10R		5R	10R
	DLM-07				3R		
	DLM-9,12	5R	5R		3R	5R	5R

2P SERIES

2-Jaw Precision Parallel Grippers | Features and Benefits | How To Order

Features:

- Robust and powerful precision multi-purpose gripper
- Pneumatic or hydraulic powered operation
- Optional tandem cylinder doubles grip force
- Protective boot and shielded design for harsh environments
- Spring assist option maintains grip in case of air pressure loss

Applications:

- Hydraulic powered gripping applications
- Confined spaces in harsh environment applications
- Welding applications with protective boot option



How To Order

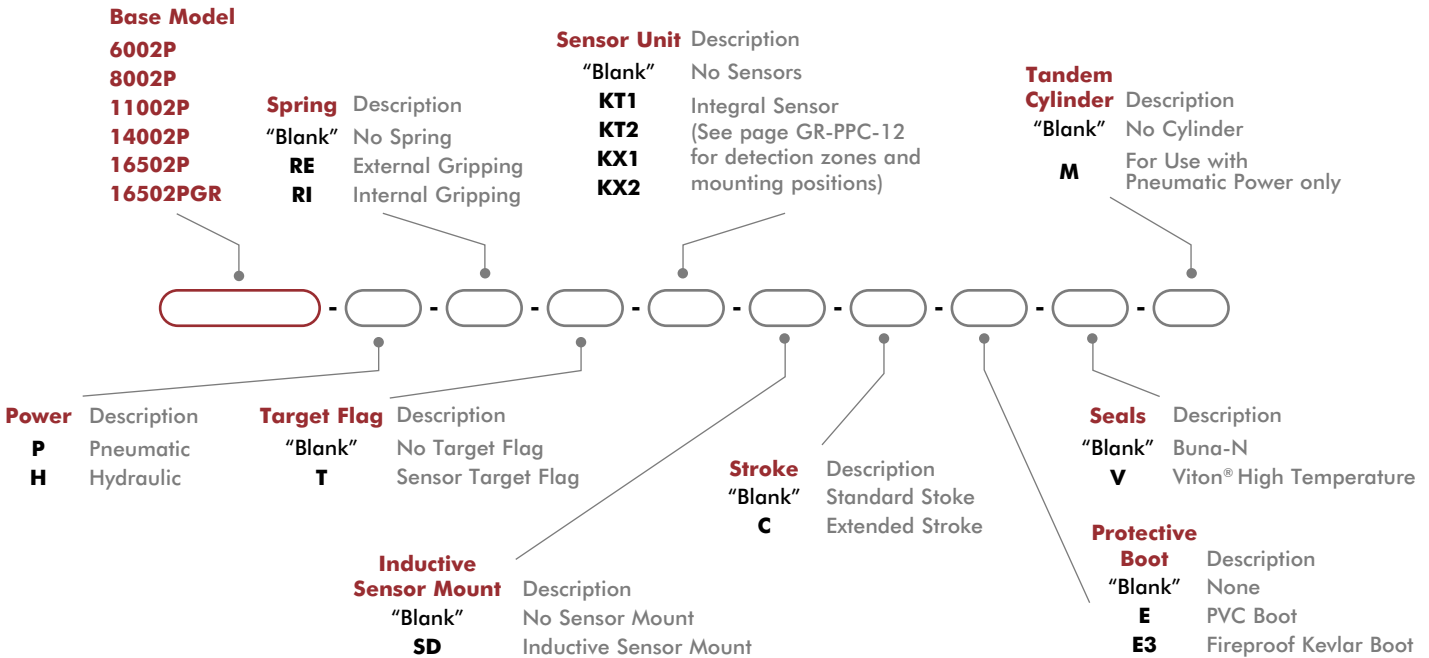

Accessories

Sensor Accessories	Model Numbers	Part Number	Qty/Unit
M8 Inductive Sensor PNP with M8 Connector	6002P, 8002P, 11002P	OISP-011	1-4
M8 Inductive Sensor NPN with M8 Connector	6002P, 8002P, 11002P	OISN-011	1-4
M8 Inductive Sensor PNP with M12 Connector	14002P, 16502P	OISP-017	1-4
M8 Inductive Sensor NPN with M12 Connector	14002P, 16502P	OISN-017	1-4
M8 Quick Disconnect 2 Meter Cable Length*	6002P, 8002P, 11002P	CABL-010	1-4
M12 Quick Disconnect 2 Meter Cable Length*	14002P, 16502P	CABL-014	1-4
Inductive Sensor Mounting Kit (1 holder + 1 flag)	6002P, 8002P	SD60-80P	1-2
Inductive Sensor Mounting Kit (1 holder + 1 flag)	11002P	SD110P	1-2
Inductive Sensor Mounting Kit (1 holder + 1 flag)	14002P	OSMK-114	1-2
Inductive Sensor Mounting Kit (1 holder + 1 flag)	16502P	OSMK-115	1-2

*Sensor and cable sold separately.

2-Jaw Precision Parallel Grippers | Technical Specifications

Specifications	Units	6002P-P	6002P-P-C	8002P-P	8002P-P-C	11002P-P	11002P-P-C
Grip Force (F6+R)1, 6 bar [87 psi], Springs Mid-Way, L=0	N [lb]	694 [156]	432 [97]	1946 [437]	1256 [282]	3043 [684]	2030 [456]
Grip Force (F0+R)2, 0 bars, Springs Mid-Way, L=0	N [lb]	176 [40]	109 [24]	635 [143]	410 [92]	965 [217]	644 [145]
Total Stroke	mm [in]	10 [0.39]	16 [0.63]	13 [0.51]	20 [0.79]	20 [0.79]	30 [1.18]
Weight	kg [lbs]	0.51 [1.12]		0.84 [1.85]		2.04 [4.50]	
Pressure Range w/o Spring	bar [psi]	2-7 [30-100]					
Pressure Range with Spring	bar [psi]	4-7 [60-100]					
Ingress Protection Class (IP)		IP54					
Displacement	cm ³ [in ³]	12 [0.73]		35 [2.14]		87 [5.31]	
Temperature Range (Buna-N seals)	°C [°F]	-35°~80° [-30°~180°]					
Temperature Range (Viton® seals)	°C [°F]	-30°~150° [-20°~300°]					
Actuation (open/close)	sec	0.07		0.08		0.10	
Repeatability	mm [in]	±0.02 [±0.001]					

Specifications	Units	14002P-P	14002P-P-C	16502P-P	16502P-P-C	1650PGR-P
Grip Force (F6+R)1, 6 bar [87 psi], Springs Mid-Way, L=0	N [lb]	6232 [1400]	4031 [906]	11475 [2579]	6878 [1546]	11475 [2579]
Grip Force (F0+R)2, 0 bars, Springs Mid-Way, L=0	N [lb]	2305 [518]	1490 [335]	3825 [860]	2292 [515]	3825 [860]
Total Stroke	mm [in]	26 [1.02]	40 [1.57]	30 [1.18]	50 [1.97]	30 [1.18]
Weight	kg [lbs]	4.2 [9.26]		8.74 [19.26]		2.04 [4.50]
Pressure Range w/o Spring	bar [psi]	2-7 Bar [30-100 psi]				
Pressure Range with Spring	bar [psi]	4-7 Bar [60-100 psi]				
Ingress Protection Class (IP)		IP54				
Displacement	cm ³ [in ³]	220 [13.43]		494 [30.15]		494 [30.15]
Temperature Range (Buna-N seals)	°C [°F]	-35°~80° [-30°~180°]				
Temperature Range (Viton® seals)	°C [°F]	-30°~150° [-20°~300°]				
Actuation (open/close)	sec	0.16		0.29		0.29
Repeatability		±0.02 [±0.001]				

6002P, 6002P-C

2-Jaw Precision Parallel Grippers | Dimensions and Technical Specifications

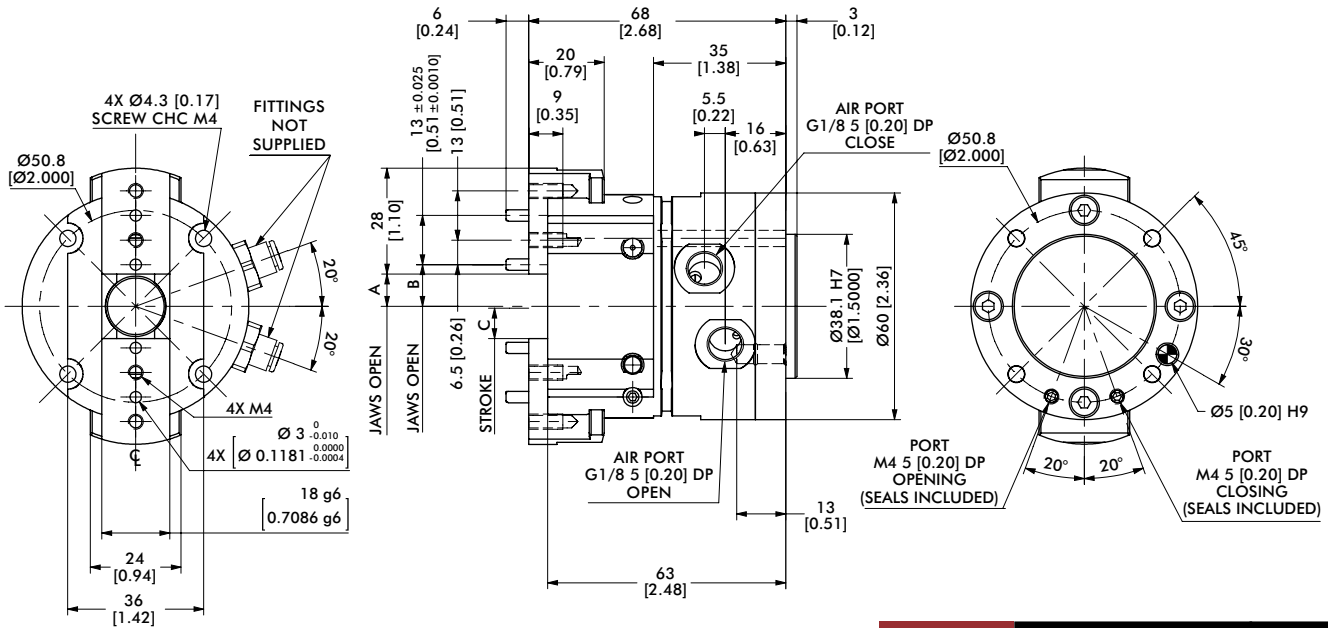

OUR GRIPPERS ARE SUPPLIED WITH OPEN SIDE AIR PORTS AND TOP AIR PORTS PLUGGED. WHEN OPERATING TOP AIR PORTS, PRODUCES MANIFOLD SEALING AS SHOWN.

GRIPPERS TOP AIR PORT
O-RING Ø1.5 X Ø4

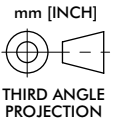

Model	A	B	C
6002P	5.5 [0.22]	8 [0.31]	5 [0.20]
6002P-C	8.5 [0.33]	11 [0.43]	8 [0.31]

Dimensions in mm [in]

Protective Boots	6002P
PVC Protective Boot, Brown or Black	ER62P
Fireproof KEVLAR Protective Boot, Red	E3R62P

Seal Repair Kits	6002P
Buna-N Seal Repair Kit	SLKT-156
Viton® Seal Repair Kit	SLKT-156V
Hydraulic Seal Repair Kit	SLKT-330

Loading Information

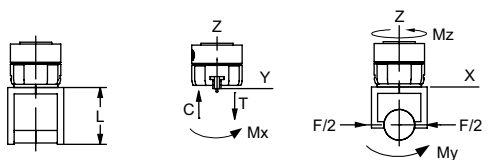
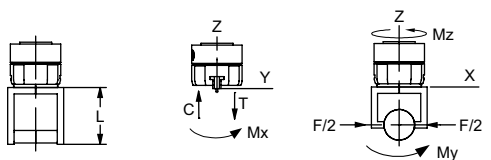
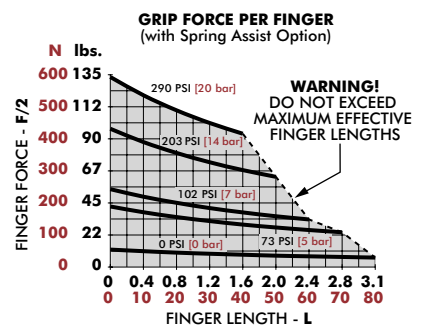
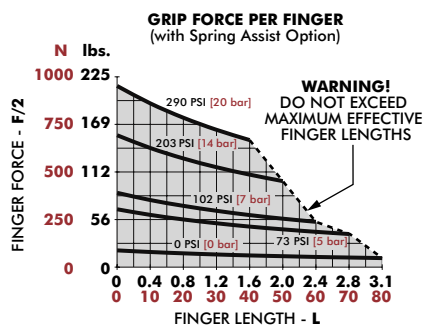

6002P	Static	Dynamic
Maximum Tensile T	410 N [92 lbs]	95 N [21 lbs]
Maximum Compressive C	780 N [175 lbs]	95 N [21 lbs]
Maximum Moment M_x	21 Nm [186 in-lbs]	3 Nm [27 in-lbs]
Maximum Moment M_y	16 Nm [142 in-lbs]	3 Nm [27 in-lbs]
Maximum Moment M_z	[239 in-lbs] 27 Nm	3 Nm [27 in-lbs]

6002P-C	Static	Dynamic
Maximum Tensile T	546 N [123 lbs]	140 N [31 lbs]
Maximum Compressive C	1037 N [233 lbs]	140 N [31 lbs]
Maximum Moment M_x	28 Nm [248 in-lbs]	4 Nm [35 in-lbs]
Maximum Moment M_y	22 Nm [195 in-lbs]	4 Nm [35 in-lbs]
Maximum Moment M_z	36 Nm [319 in-lbs]	4 Nm [35 in-lbs]

*Capacities are per set of jaws and are not simultaneous

*Capacities are per set of jaws and are not simultaneous

8002P, 8002P-C

2-Jaw Precision Parallel Grippers | Dimensions and Technical Specifications

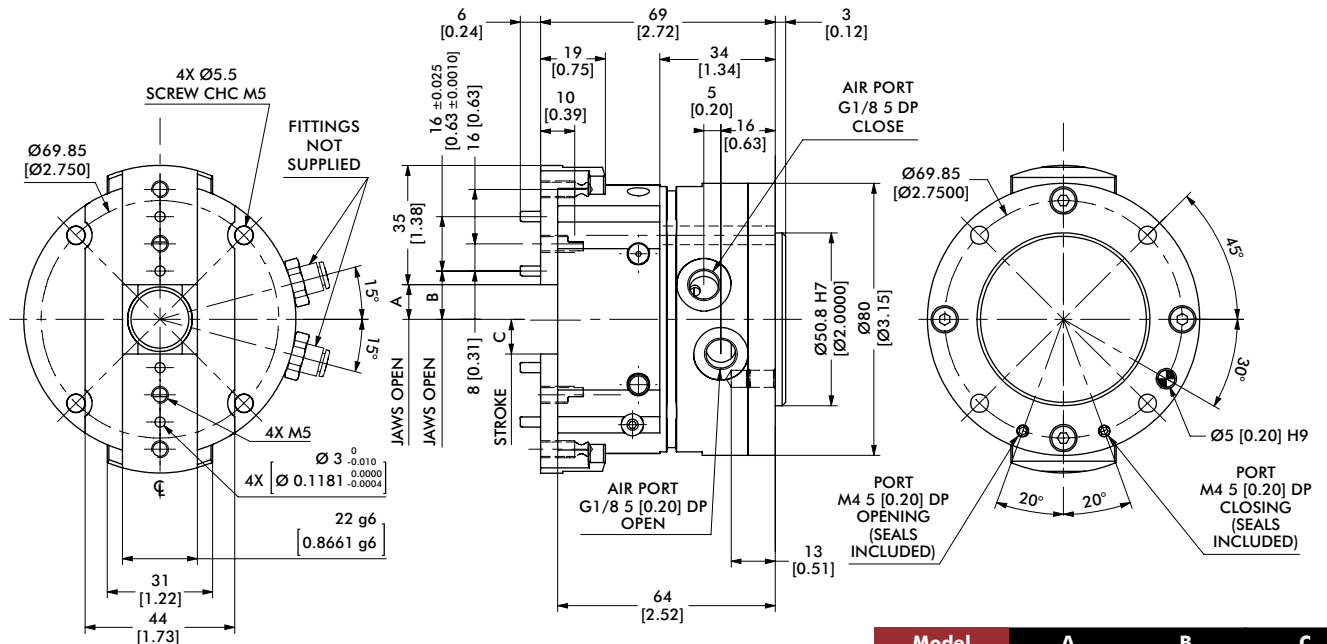

OUR GRIPPERS ARE SUPPLIED WITH OPEN SIDE AIR PORTS AND TOP AIR PORTS PLUGGED. WHEN OPERATING TOP AIR PORTS, PRODUCES MANIFOLD SEALING AS SHOWN.

GRIPPERS TOP AIR PORT
 Ø3 [Ø0.12]
 1.2 [0.05]
 O-RING Ø1.5 X Ø4

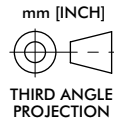

Model	A	B	C
8002P	6.8 [0.27]	10.8 [0.43]	6.5 [0.26]
8002P-C	10.2 [0.40]	14.2 [0.56]	10 [0.39]

Dimensions in mm [in]

Protective Boots	8002P
PVC Protective Boot, Brown or Black	ER82P
Fireproof KEVLAR Protective Boot, Red	E3R82P

Seal Repair Kits	8002P
Buna-N Seal Repair Kit	S80
Viton® Seal Repair Kit	S80V
Hydraulic Seal Repair Kit	S80H

Loading Information

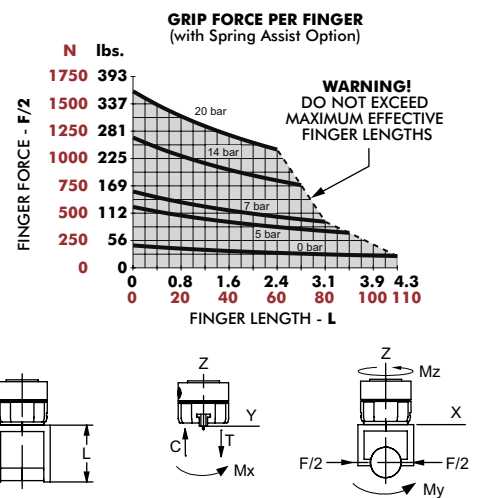
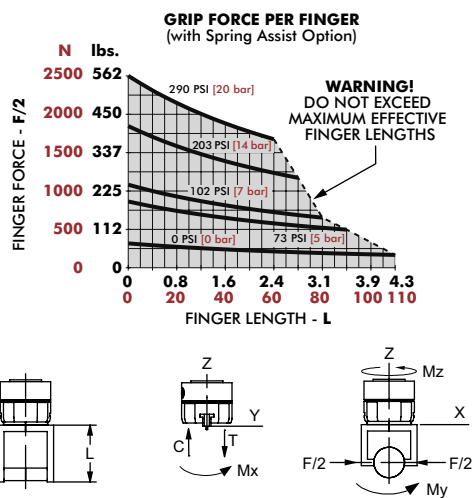

8002P	Static	Dynamic
Maximum Tensile T	819 N [184 lbs]	348 N [78 lbs]
Maximum Compressive C	1383 N [311 lbs]	348 N [78 lbs]
Maximum Moment M_x	40 Nm [354 in-lbs]	13 Nm [115 in-lbs]
Maximum Moment M_y	45 Nm [398 in-lbs]	15 Nm [133 in-lbs]
Maximum Moment M_z	25 Nm [221 in-lbs]	15 Nm [133 in-lbs]

8002P-C	Static	Dynamic
Maximum Tensile T	615 N [138 lbs]	236 N [53 lbs]
Maximum Compressive C	1040 N [234 lbs]	236 N [53 lbs]
Maximum Moment M_x	30 Nm [266 in-lbs]	9 Nm [80 in-lbs]
Maximum Moment M_y	33 Nm [292 in-lbs]	10 Nm [89 in-lbs]
Maximum Moment M_z	18 Nm [159 in-lbs]	10 Nm [89 in-lbs]

¹Capacities are per set of jaws and are not simultaneous

¹Capacities are per set of jaws and are not simultaneous

11002P, 11002P-C

2-Jaw Precision Parallel Grippers | Dimensions and Technical Specifications

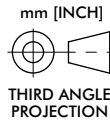
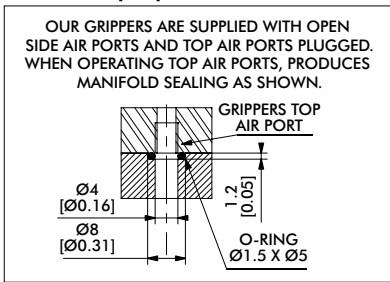
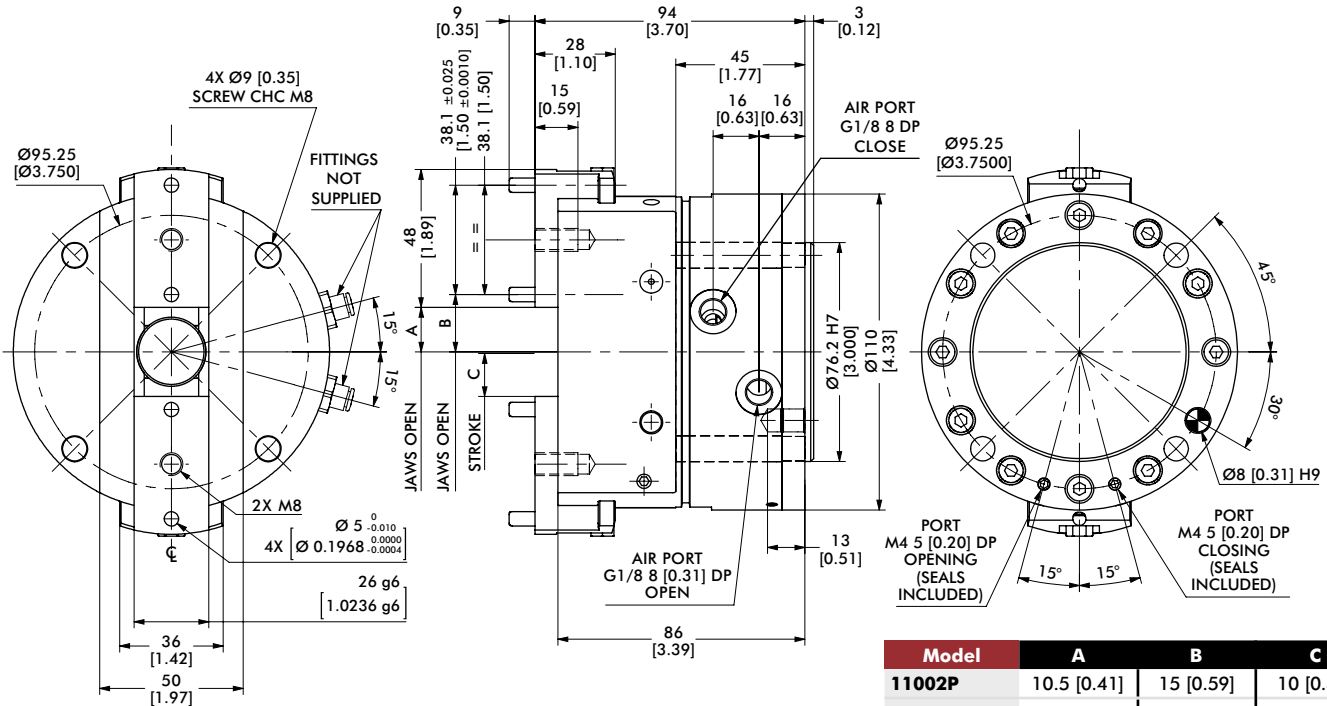

Model	A	B	C
11002P	10.5 [0.41]	15 [0.59]	10 [0.39]
11002P-C	15.5 [0.61]	20 [0.79]	15 [0.59]

Dimensions in mm [in]

Protective Boots	11002P
PVC Protective Boot, Brown or Black	ER112P
Fireproof KEVLAR Protective Boot, Red	E3R112P

Seal Repair Kits	11002P
Buna-N Seal Repair Kit	S110
Viton® Seal Repair Kit	S110V
Hydraulic Seal Repair Kit	S110H

Loading Information

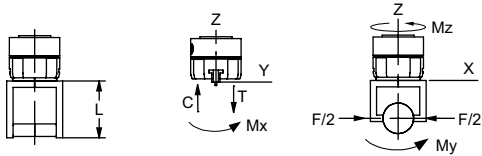
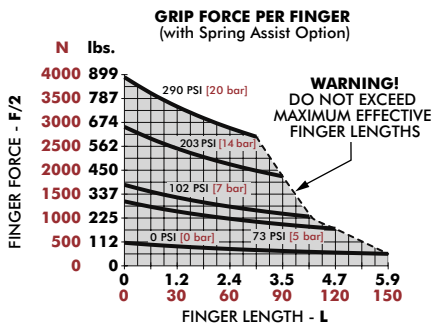

11002P	Static	Dynamic
Maximum Tensile T	1040 N [234 lbs]	556 N [125 lbs]
Maximum Compressive C	1768 N [397 lbs]	556 N [125 lbs]
Maximum Moment M_x	39 Nm [345 in-lbs]	25 Nm [221 in-lbs]
Maximum Moment M_y	53 Nm [469 in-lbs]	33 Nm [292 in-lbs]
Maximum Moment M_z	63 Nm [558 in-lbs]	33 Nm [292 in-lbs]

*Capacities are per set of jaws and are not simultaneous

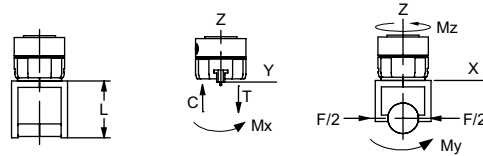
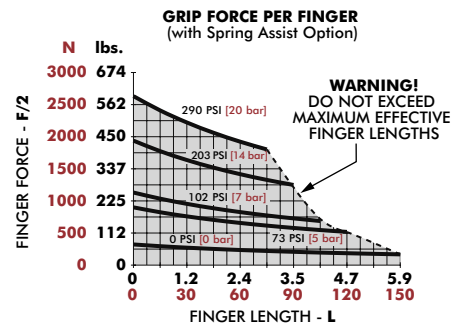

11002P-C	Static	Dynamic
Maximum Tensile T	945 N [212 lbs]	370 N [83 lbs]
Maximum Compressive C	1607 N [361 lbs]	370 N [83 lbs]
Maximum Moment M_x	35 Nm [310 in-lbs]	18 Nm [159 in-lbs]
Maximum Moment M_y	47 Nm [416 in-lbs]	24 Nm [212 in-lbs]
Maximum Moment M_z	56 Nm [496 in-lbs]	24 Nm [212 in-lbs]

*Capacities are per set of jaws and are not simultaneous

14002P, 14002P-C

2-Jaw Precision Parallel Grippers | Dimensions and Technical Specifications

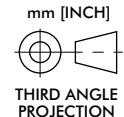
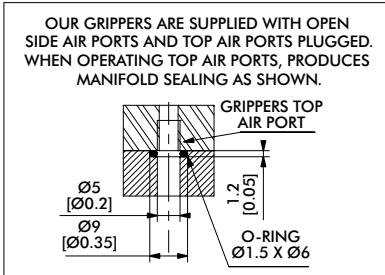
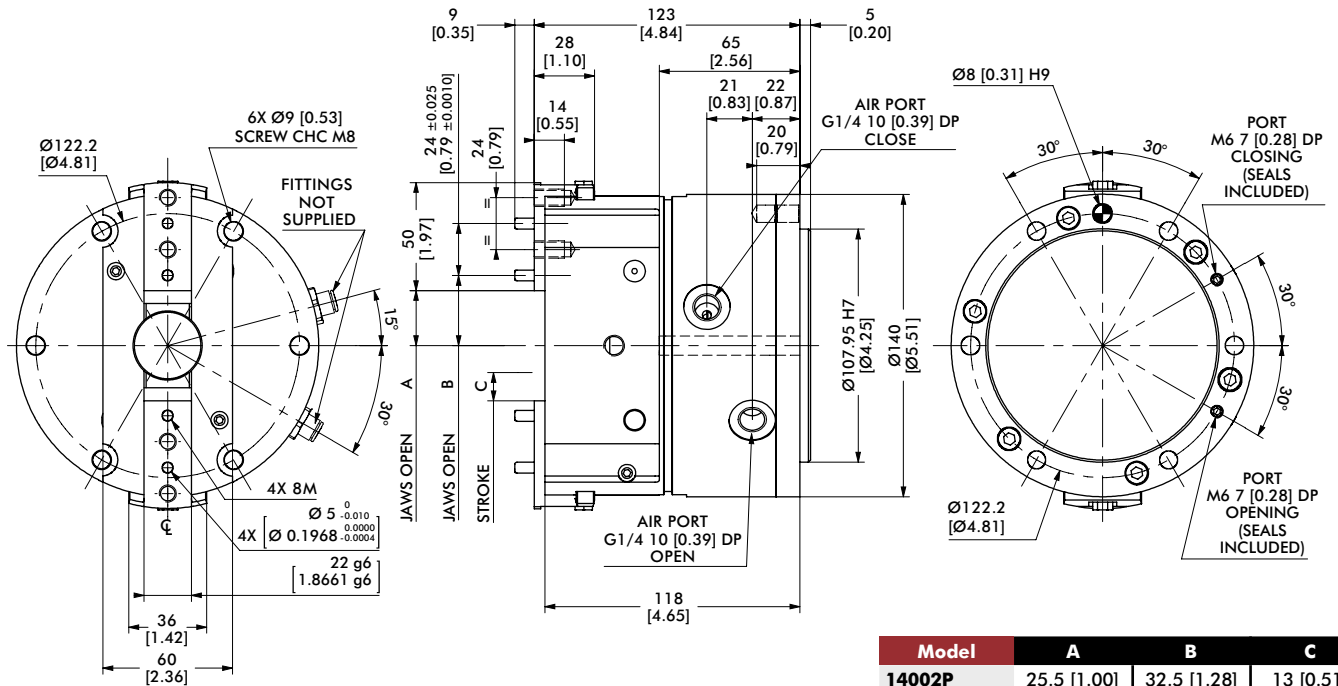

Model	A	B	C
14002P	25.5 [1.00]	32.5 [1.28]	13 [0.51]
14002P-C	32.5 [1.28]	39.5 [1.56]	20 [0.79]

Dimensions in mm [in]

Protective Boots	14002P
PVC Protective Boot, Brown or Black	KP-311
Fireproof KEVLAR Protective Boot, Red	KP-313

Seal Repair Kits	14002P
Buna-N Seal Repair Kit	SLKT-333
Viton® Seal Repair Kit	SLKT-333V
Hydraulic Seal Repair Kit	SLKT-334

Loading Information

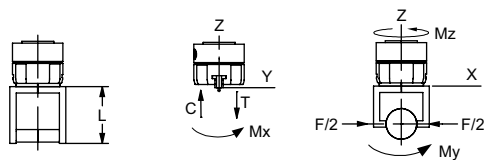
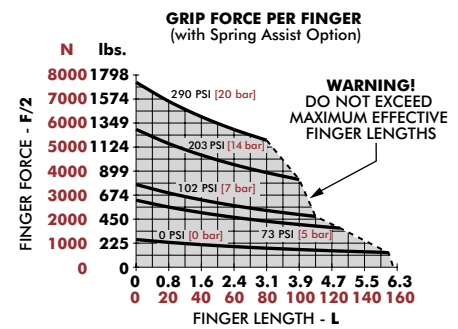

14002P	Static	Dynamic
Maximum Tensile T	1600 N [360 lbs]	550 N [124 lbs]
Maximum Compressive C	1820 N [409 lbs]	550 N [124 lbs]
Maximum Moment M_x	55 Nm [487 in-lbs]	18 Nm [159 in-lbs]
Maximum Moment M_y	90 Nm [797 in-lbs]	30 Nm [266 in-lbs]
Maximum Moment M_z	90 Nm [797 in-lbs]	30 Nm [266 in-lbs]

[†]Capacities are per set of jaws and are not simultaneous

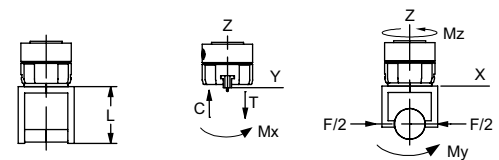
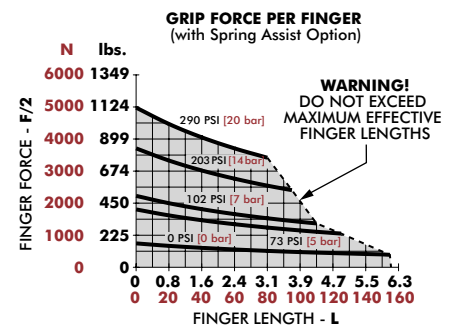

14002P-C	Static	Dynamic
Maximum Tensile T	1450 N [326 lbs]	400 N [90 lbs]
Maximum Compressive C	1450 N [326 lbs]	400 N [90 lbs]
Maximum Moment M_x	50 Nm [443 in-lbs]	15 Nm [133 in-lbs]
Maximum Moment M_y	75 Nm [664 in-lbs]	25 Nm [221 in-lbs]
Maximum Moment M_z	75 Nm [664 in-lbs]	25 Nm [221 in-lbs]

[†]Capacities are per set of jaws and are not simultaneous

16502P, 16502P-C

2-Jaw Precision Parallel Grippers | Dimensions and Technical Specifications

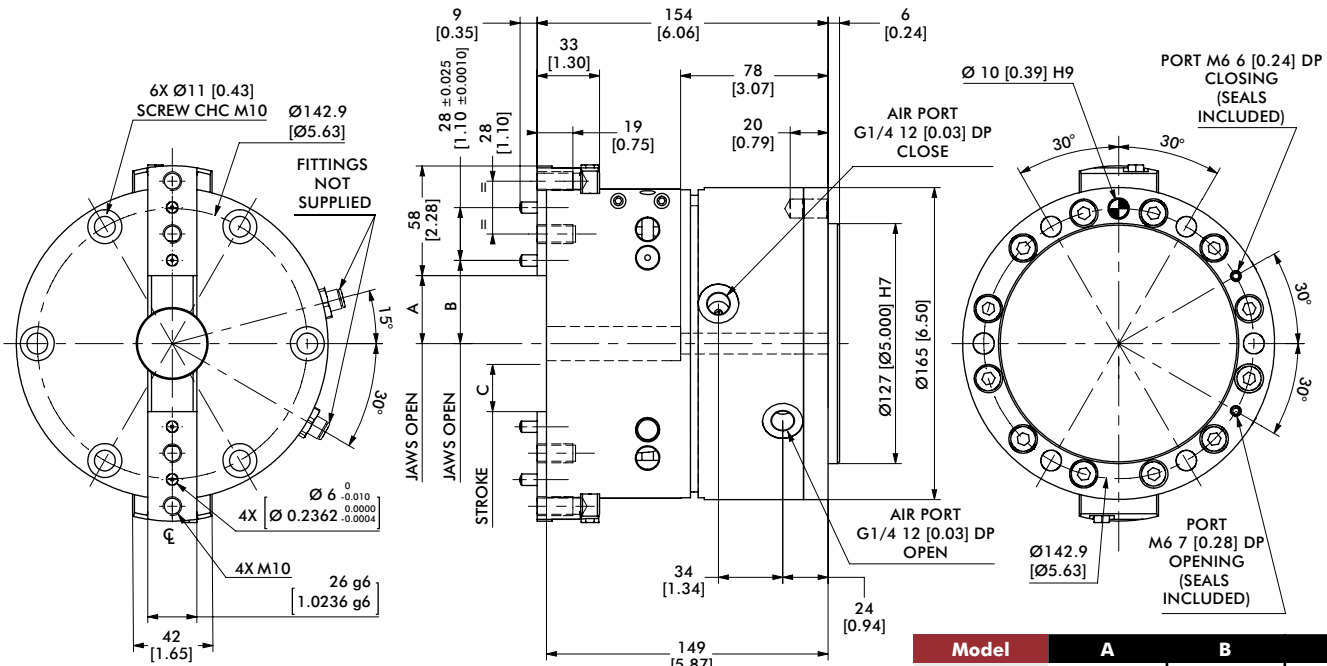

OUR GRIPPERS ARE SUPPLIED WITH OPEN SIDE AIR PORTS AND TOP AIR PORTS PLUGGED. WHEN OPERATING TOP AIR PORTS, PRODUCES MANIFOLD SEALING AS SHOWN.

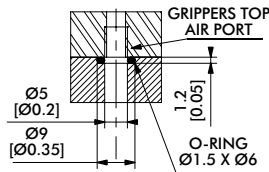

mm [INCH]
THIRD ANGLE PROJECTION

Model	A	B	C
16502P	31 [1.22]	39 [1.54]	15 [0.59]
16502P-C	36 [1.42]	44 [1.73]	25 [0.98]

Dimensions in mm [in]

Protective Boots	16502P
PVC Protective Boot, Brown or Black	KP-314
Fireproof KEVLAR Protective Boot, Red	KP-316
Seal Repair Kits	16502P
Buna-N Seal Repair Kit	SLKT-335
Viton® Seal Repair Kit	SLKT-335V
Hydraulic Seal Repair Kit	SLKT-336

Loading Information

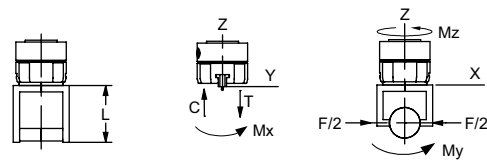
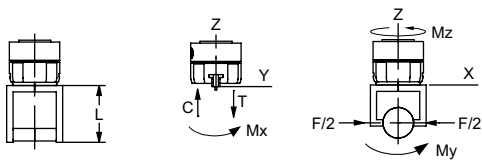
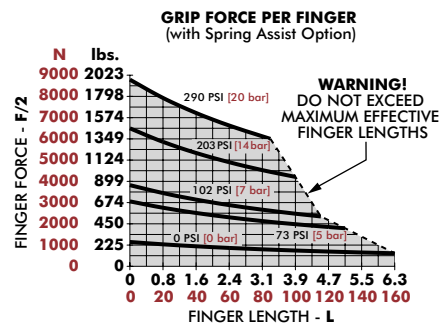
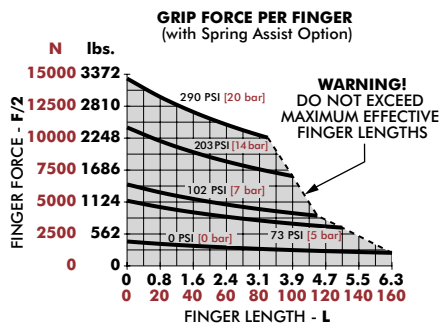

16502P	Static	Dynamic
Maximum Tensile T	1720 N [387 lbs]	650 N [146 lbs]
Maximum Compressive C	2160 N [485 lbs]	650 N [146 lbs]
Maximum Moment M_x	70 Nm [620 in-lbs]	17 Nm [150 in-lbs]
Maximum Moment M_y	100 Nm [885 in-lbs]	30 Nm [266 in-lbs]
Maximum Moment M_z	100 Nm [885 in-lbs]	30 Nm [266 in-lbs]

*Capacities are per set of jaws and are not simultaneous

16502P-C	Static	Dynamic
Maximum Tensile T	1550 N [348 lbs]	580 N [130 lbs]
Maximum Compressive C	1950 N [438 lbs]	580 N [130 lbs]
Maximum Moment M_x	60 Nm [531 in-lbs]	20 Nm [177 in-lbs]
Maximum Moment M_y	80 Nm [708 in-lbs]	25 Nm [221 in-lbs]
Maximum Moment M_z	90 Nm [797 in-lbs]	25 Nm [221 in-lbs]

*Capacities are per set of jaws and are not simultaneous

2-Jaw Precision Parallel Grippers | Dimensions and Technical Specifications

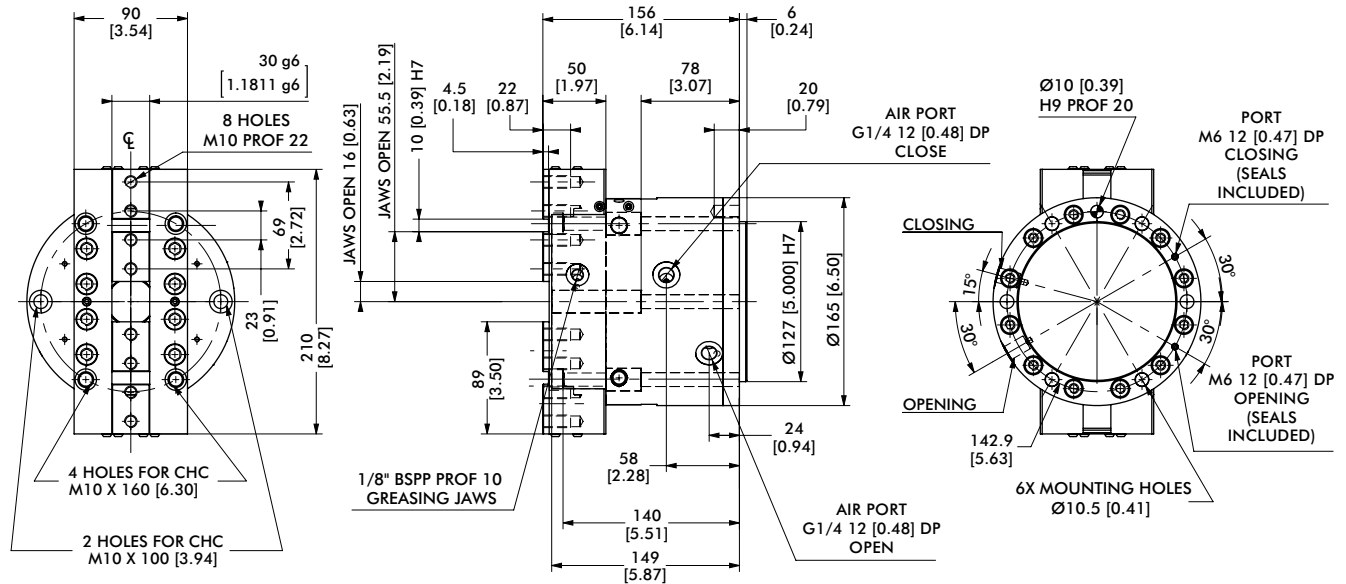

OUR GRIPPERS ARE SUPPLIED WITH OPEN SIDE AIR PORTS AND TOP AIR PORTS PLUGGED. WHEN OPERATING TOP AIR PORTS, PRODUCES MANIFOLD SEALING AS SHOWN.

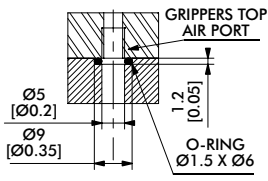

mm [INCH]

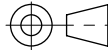

THIRD ANGLE PROJECTION

Protective Boots	16502PGR
Fireproof KEVLAR Protective Boot, Red	KENVE2-21384
Seal Repair Kits	16502PGR
Buna-N Seal Repair Kit	SLKT-335
Viton® Seal Repair Kit	SLKT-335V
Hydraulic Seal Repair Kit	SLKT-336

Loading Information

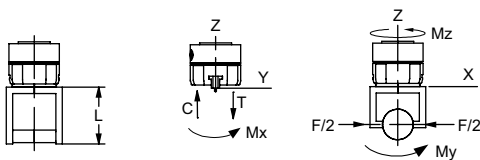
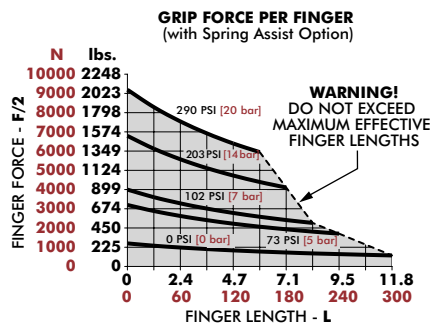

16502PGR	Static
Maximum Tensile T	5200 N [1169 lbs]
Maximum Compressive C	6400 N [1438 lbs]
Maximum Moment M_x	270 Nm [2390 in-lbs]
Maximum Moment M_y	350 Nm [3098 in-lbs]
Maximum Moment M_z	300 Nm [2655 in-lbs]

†Capacities are per set of jaws and are not simultaneous

2P OPTIONS & ACCESSORIES

2-Jaw Parallel Grippers | Dimensions and Technical Specifications

SUPPLY: (P) Pneumatic (H) Hydraulic

As standard, the clamp is supplied with air to a pressure of 7 bar. On request (contact us) the gripper can be supplied with hydraulic fluid. The clamp is fitted with seals Viton Quad-Ring.

- Choice (H) allows a hydraulic power to a pressure of 20 bar max. In this case the overall dimensions do not change. For better security the gripper must be fixed on their support before being fired.

CAUTION: Hydraulic cycle times are longer.

The hydraulic power is incompatible with the option tandem (M).

Option (RE) or (RI): Spring Assist

The internal springs of the gripper ensures grip force is maintained by retaining the component during pressure loss, to increase the gripforce, or allows the usage of the gripper in single acting operation.

Option (RE) for external gripping. Option (RI) for internal gripping.

The (RE) is incompatible with the option (RI).

Option (T): Sensor Rod

Option (T) is a steel rod which comes out on the rear side of the gripper. The rod is fixed with the piston and has the same stroke movement. The open end of the rod allows for mounting a cam which allows to control the position of the jaws by using inductive sensors, micro switches, etc

WARNING: when screwing on cam rod, make sure the sensor rod does not rotate to prevent twisting of the springs of options (RE) or (RI).

Option (T) is incompatible with option (K).

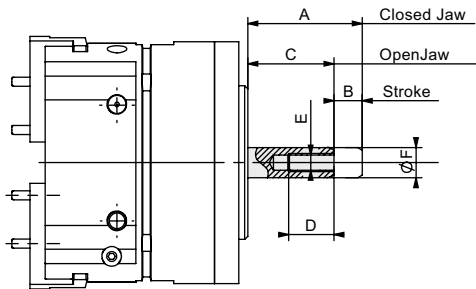

Model	A	B	C	D	E	F
6002P & 6002P-C	35	5	30	15	M6	10
8002P & 8002P-C	35	6.5	28.5	15	M6	10
11002P & 11002P-C	35	10	25	15	M6	15
14002P & 14002P-C	55	13	42	20	M8	15
16502P & 16502P-C	53	23	30	20	M8	15

Option (M): Tandem Cylinder

The (M) is a cylinder light-alloy that fits behind the bottom plate. This actuator's integral action allows to double the gripforce by using the same pressure. The combination of tandem option tandem (M) and Option (RE) or (RI) can double the clamping forces of the spring assist option. For cycle times of the tandem option, apply a factor of 3 to the actuation time.

The (M) is incompatible with the option (H).

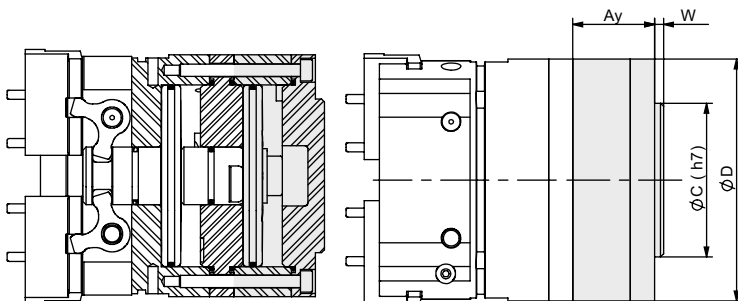

Model	Ay	ØC	ØD	W	Weight (kg)
6002P & 6002P-C	28.5	38.1	60	3	0.200
8002P & 8002P-C	27	50.8	80	3	0.300
11002P & 11002P-C	34	76.2	110	3	0.750
14002P & 14002P-C	49	107.95	140	5	2.100
16502P & 16502P-C	65	127	165	6	3.600

2P OPTIONS & ACCESSORIES

2-Jaw Parallel Grippers | Dimensions and Technical Specifications

Option (KT1), (KX1), (KT2), (KX2): Sensor Unit

The **(K)** is a lightweight alloy housing that fits on the back of the gripper. An integrated shaft follows the movement of the piston to provide information to the sensor attached to the side of the unit. It can control two positions of the grippers jaws. 2 types of inductive sensors (**KT, KX**) and 2 detection zones (**1, 2**) are possible to allow for the combination of 2 to 4 possible positions (**KT1, KX1, KT2, KX2**). For **KT, KX** sensor specifications.

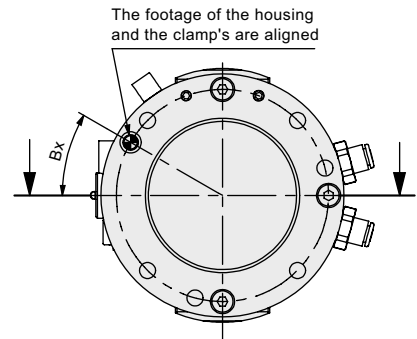
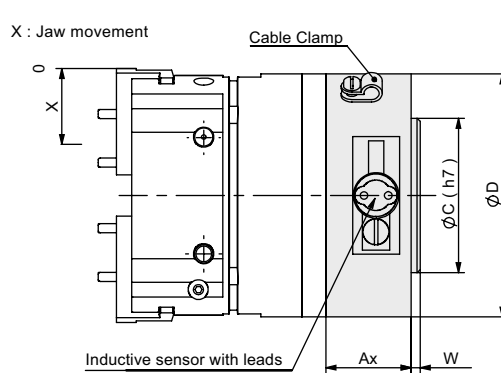
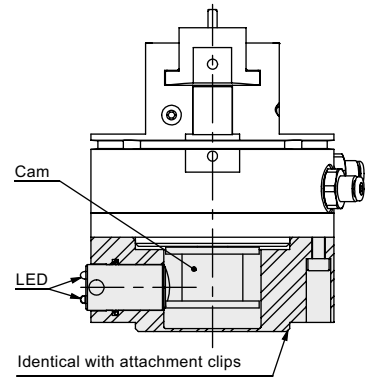

Model	Ax	Bx	ØC	ØD	W	Weight (kg)	No. of Sensing Positions (please specify when ordering)	Information area from the open grip position (green LED) X (mm)	Area information relative to the closed grip position (yellow LED) X (mm)
6002P	23	30°	38.1	60	3	0.180	1	0 or 1	4
							2	0 or 2	3
6002P-C	23	30°	38.1	60	3	0.180	1	0 or 1.6	7
							2	0 or 3.2	4.8
8002P	28	30°	50.8	80	3	0.400	1	0 or 1	5.5
							2	0 or 2	4.5
8002P-C	28	30°	50.8	80	3	0.400	1	0 or 1.5	8.5
							2	0 or 3.1	6.9
11002P	36	30°	76.2	110	3	0.900	1	0 or 1	9
							2	0 or 3	7
11002P-C	36	30°	76.2	110	3	0.900	1	0 or 1.5	13.5
							2	0 or 4.5	10.5
14002P	45.5	165°	107.95	140	5	1.670	1	0 or 2	11
							2	0 or 4	9
14002P-C	45.5	165°	107.95	140	5	1.670	1	0 or 3	17
							2	0 or 6.2	13.8
16002P	65.5	165°	127	165	6	2.670	1	0 or 2	13
							2	0 or 4	11
16002P-C	65.5	165°	127	165	6	2.670	1	0 or 3.3	21.7
							2	0 or 7	18

2P OPTIONS & ACCESSORIES

2-Jaw Parallel Grippers | Dimensions and Technical Specifications

Option (V): Viton® Seals

Gripper with Viton® seals allows for use in high temperature environments [-30 ° C or 150 ° C].

Accessory (E): Protective Boot

The accessory (E) is a protective boot that fits over the gripper. It protects the mechanism and thus improves the life of the gripper in hostile environments. The accessory (E) causes a different location of the fingers on the jaws as compared to the standard installation. Before attaching the boot, perform the following steps:

1. Mount gripper to machine.
2. Slip boot over gripper and secure in place.
3. Attached fingers to jaws using finger adapter.

Depending on the environment 2 types of envelopes are available:

- (E) Envelope of black or brown PVC for environmental grinding with emery presence.
- (E3) red envelope containing KEVLAR fireproof silicone environment for hot chips and weld spatter.

The accessory (E) is incompatible with the accessory (SD)

Model Code	Order #	Model	A	B	C	D	E	F	G	H	J	K	S	T	TX	V	Y
E	ER62P	6002P & 6002P-C	88	98	35	13.5	8	29	29	17.5	13	-	3	M4	9	13	6
E3	E3R62P																
E	ER82P	8002P & 8002P-C	89	110	34	13.5	10	33	30	22.3	16	-	3	M5	10	16	6
E3	E3R82P																
E	ER112P	11002P & 11002P-C	See Drawing														
E3	E3R112P																
E	KP-311	14002P & 14002P-C	143	185	50	18	12	55	34	19.5	24	18	5	M8	14	-	8
E3	KP-313																
E	KP-314	16002P & 16002P-C	172	220	70	16	14	67	37	24 19	28	23	6	M10	19	-	8
E3	KP-316																

6002P & 8002P

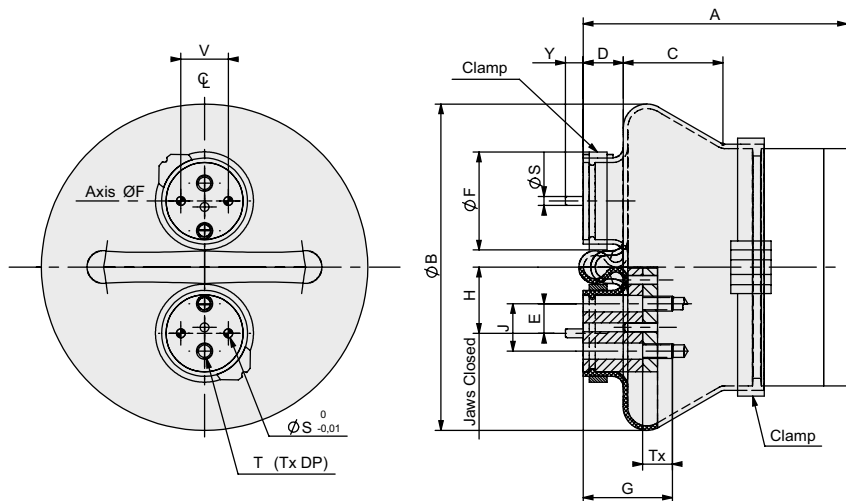

2P OPTIONS & ACCESSORIES

2-Jaw Parallel Grippers | Dimensions and Technical Specifications

11002P

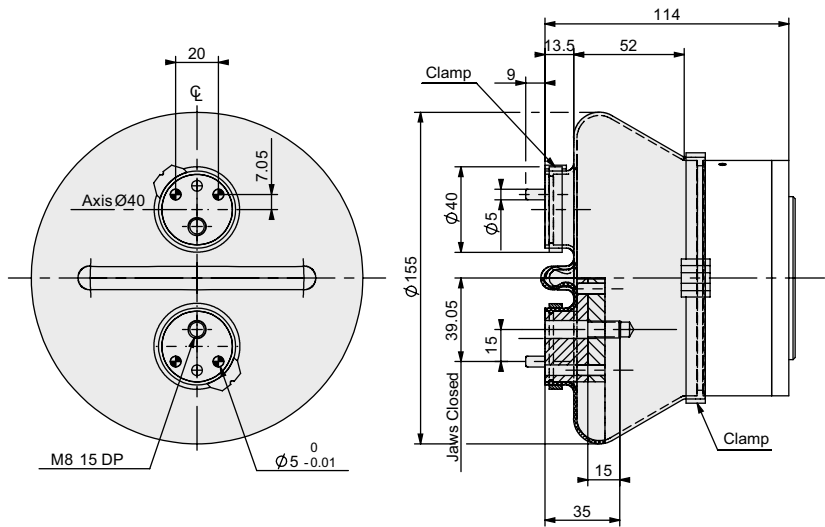

14002P & 16502P

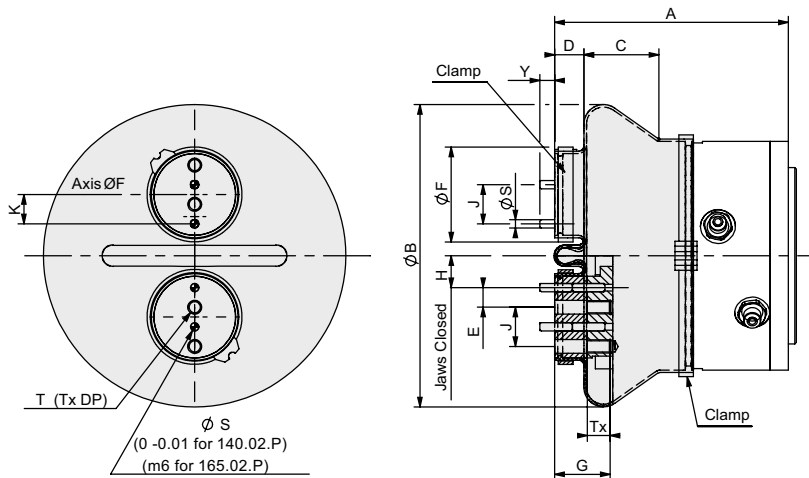

Accessory (SD): Inductive Sensor Mounting Kit

Allows for sensing of two positions: open and closed jaw. The accessory kit (SD) includes: 1 sensor bracket, 1 flag and screws. **Sensors are not provided.**

NOTES: To be usable, the cylindrical inductive sensors selected by the customer must have tapped their bodies to a minimum depth H (see table below).

Depending on their length, the cylindrical inductive sensors can extend below the clamp, requiring provision of suitable housing in the surrounding parts. It is possible to control more than 2 positions using a second attachment (SD).

Ability to adapt a second set of sensors on this jaw

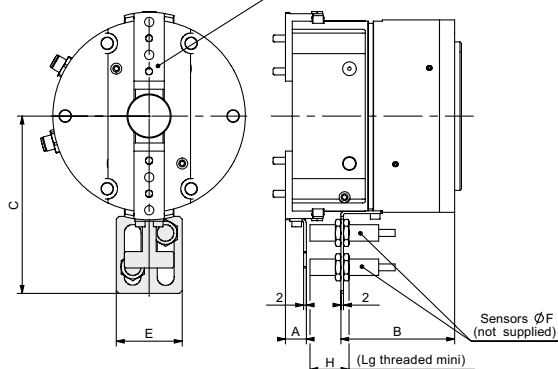

Order #	Model	A	B	C	E	F	H
SD60-80P	6002P & 6002P-C	20	35	67	32	8	35
SD60-80P	8002P & 8002P-C	19	34	77	32	8	35
SD110P	11002P & 11002P-C	19.5	45	97	32	8	35
OSMK-114	14002P & 14002P-C	15	83	129	48	12	28.5
OSMK-115	16502P & 16502P-C	29	96	147	48	12	33

DGC/GC SERIES

2-Jaw Precision Parallel Grippers | Features and Benefits | How To Order

Features:

- Rugged, high precision long stroke gripper
- High impact resistant with double wedge design
- Versatile mounting on top or sides of gripper
- Spring assist option maintains grip in case of air pressure loss
- Two end of stroke inductive sensing positions supported
- DIRECTCONNECT™ mounting (DGC only)
- Shielded design to repel chips and particulates

Applications:

- Machining and harsh environment applications
- High vibration and impact applications
- Pick and Place applications

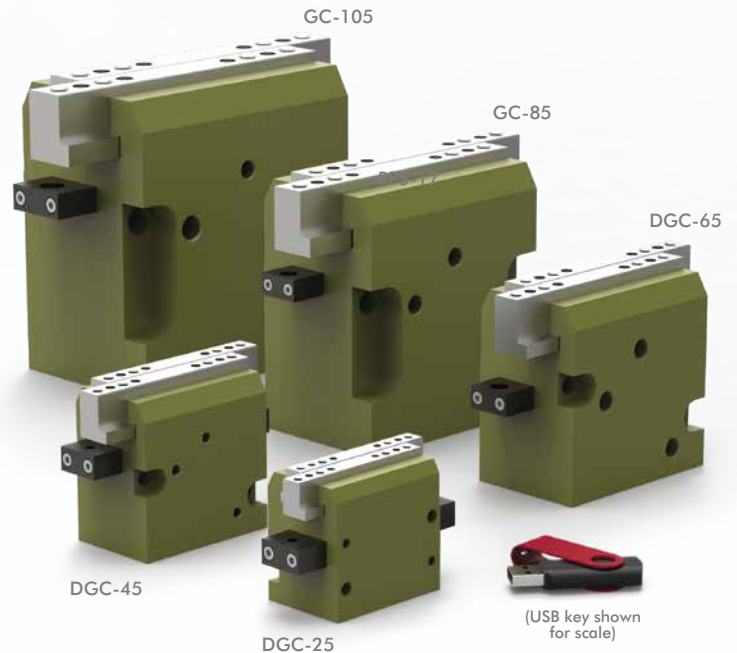

How To Order

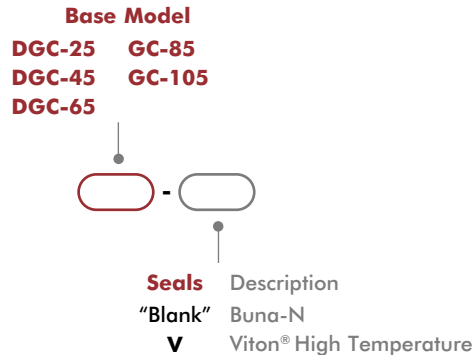

Accessories

Sensor Accessories	Model Numbers	Part Number	Qty/Unit
4mm NPN Inductive Sensor with Quick Disconnect*	25, 45	OISN-014	1-2
4mm PNP Inductive Sensor with Quick Disconnect*	25, 45	OISP-014	1-2
8mm NPN Inductive Sensor with Quick Disconnect*	65, 85	OISN-011	1-2
8mm PNP Inductive Sensor with Quick Disconnect*	65, 85	OISP-011	1-2
12mm NPN Inductive Sensor with Quick Disconnect*	105	OISN-017	1-2
12mm PNP Inductive Sensor with Quick Disconnect*	105	OISP-017	1-2
Quick Disconnect 2 Meter Cable Length*	24, 45, 65, 85	CABL-010	1-2
Quick Disconnect 5 Meter Cable Length*	24, 45, 65, 85	CABL-013	1-2
Quick Disconnect 2 Meter Cable Length*	105	CABL-014	1-2
Quick Disconnect 5 Meter Cable Length*	105	CABL-018	1-2

*Sensor and cable sold separately.

2-Jaw Precision Parallel Grippers | Technical Specifications

Specifications	Units	25	45	65	85	105
Total Rated Grip Force F @ 100 psi [7 bar]	N [lb]	474 [106]	481 [108]	796 [179]	1480 [333]	2318 [521]
Total Stroke	mm [in]	20 [0.787]	30 [1.181]	40 [1.575]	50 [1.968]	60 [2.362]
Weight	kg [lbs]	0.35 [0.77]	0.60 [1.32]	1.30 [2.87]	2.20 [4.85]	4.31 [9.50]
Pressure Range	bar [psi]	3-7 [45-100]				
Ingress Protection Class (IP)		IP54				
Displacement	cm ³ [in ³]	16 [0.98]	29 [1.77]	62 [3.78]	136 [8.30]	261 [15.93]
Temperature Range (Buna-N seals)	°C [°F]	-35°~80° [-30°~180°]				
Temperature Range (Viton® seals)	°C [°F]	-30°~150° [-20°~300°]				
Actuation (open/close)	sec	0.20	0.25	0.35	0.50	0.70
Accuracy	mm [in]	±0.02 [±0.0009]				
Repeatability	mm [in]	±0.01 [±0.0004]				
Valve to Required Actuate Single Acting		3-way, 2-position				
Valve to Required Actuate Double Acting		4-way, 2-position				

2-Jaw Precision Parallel Grippers | Dimensions and Technical Specifications

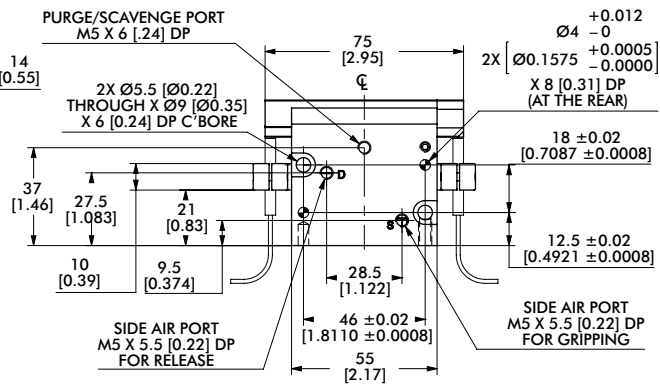
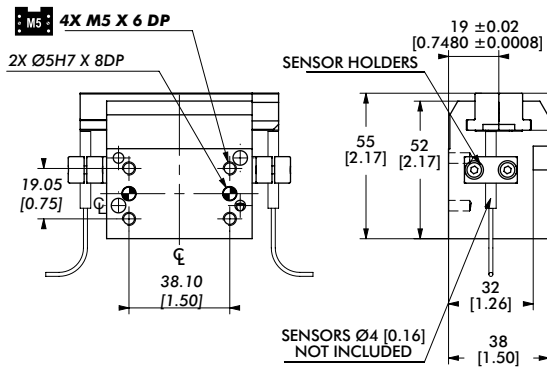
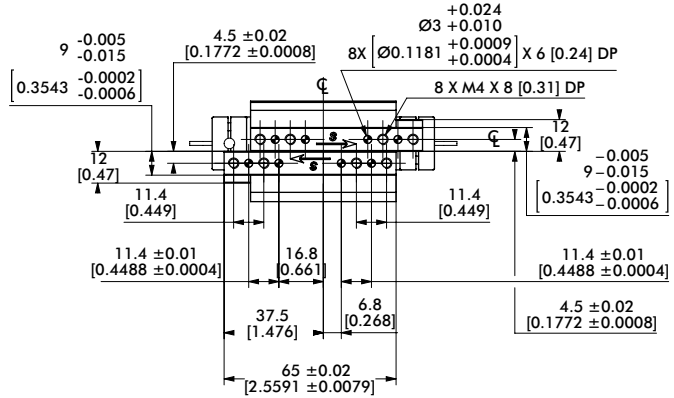
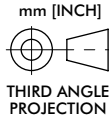
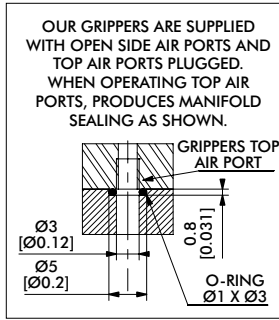

NOTE:

To benefit from safety springs power, on open or on close, gripper must always be operated with "S" for GRIPPING and with "D" for RELEASE.

Drawing hereafter shows gripper gripping at the end of stroke (inlet through "S")

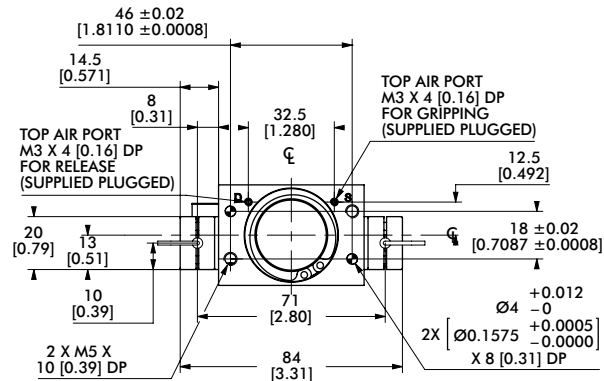

Seal Repair Kits	DGC-25
Buna-N Seal Repair Kit	SLKT-319
Viton® Seal Repair Kit	SLKT-319V

Loading Information

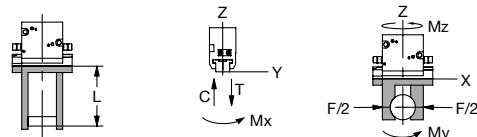
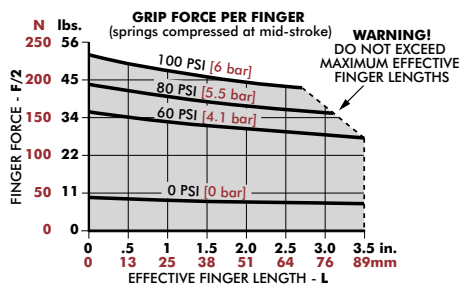

DGC-25	Static	Dynamic
Maximum Tensile T	125 N [28 lbs]	25 N [6 lbs]
Maximum Compressive C	145 N [33 lbs]	29 N [7 lbs]
Maximum Moment M_x	2 Nm [18 in-lbs]	0.5 Nm [4 in-lbs]
Maximum Moment M_y	4 Nm [35 in-lbs]	1 Nm [9 in-lbs]
Maximum Moment M_z	6 Nm [53 in-lbs]	1.5 Nm [13 in-lbs]

*Capacities are per set of jaws and are not simultaneous

2-Jaw Precision Parallel Grippers | Dimensions and Technical Specifications

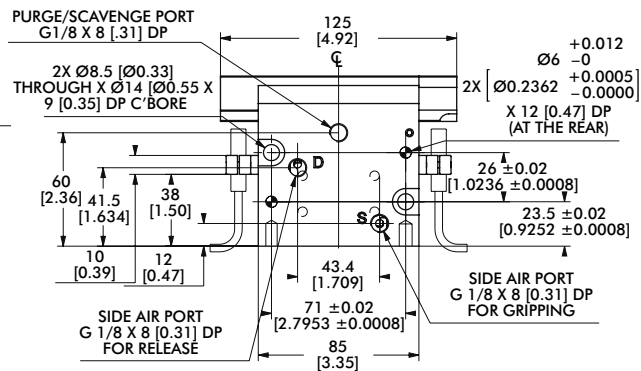
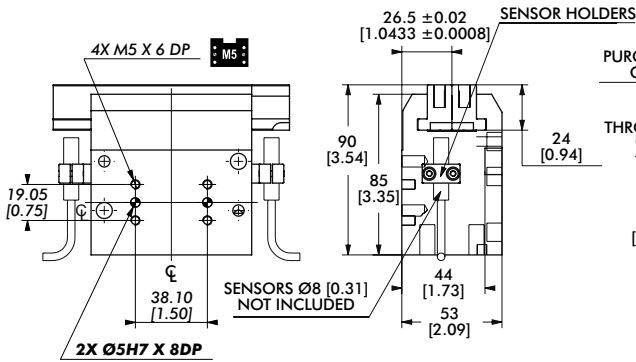
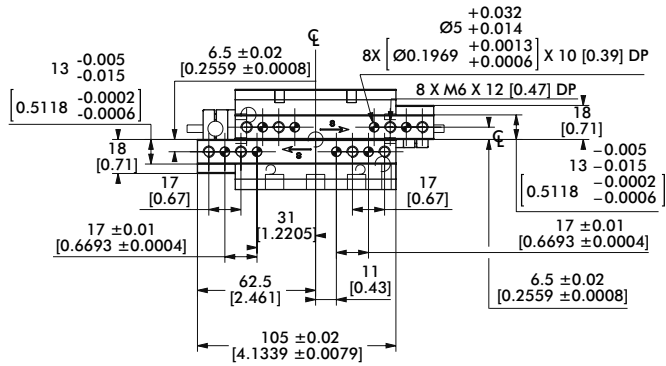
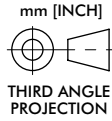
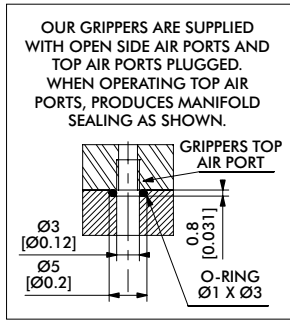

NOTE:

To benefit from safety springs power, on open or on close, gripper must always be operated with "S" for GRIPPING and with "D" for RELEASE.

Drawing hereafter shows gripper gripping at the end of stroke (inlet through "S")

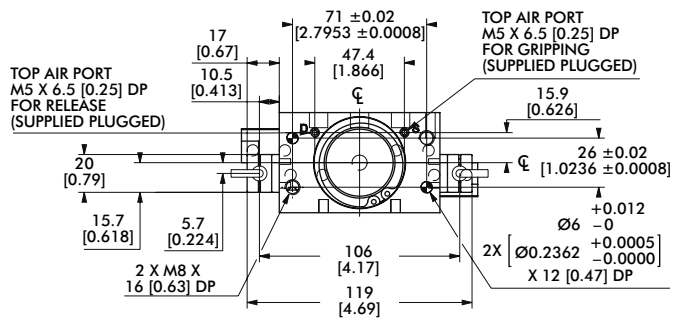

Seal Repair Kits	DGC-65
Buna-N Seal Repair Kit	SLKT-323
Viton® Seal Repair Kit	SLKT-323V

Loading Information

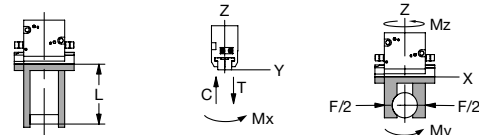
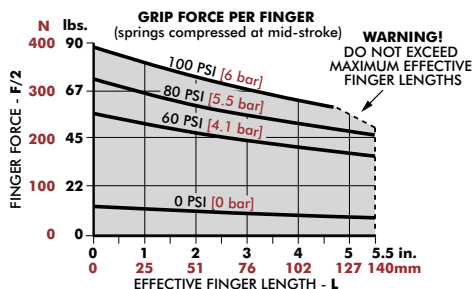

DGC-65	Static	Dynamic
Maximum Tensile T	270 N [61 lbs]	54 N [12 lbs]
Maximum Compressive C	305 N [69 lbs]	61 N [14 lbs]
Maximum Moment M_x	4 Nm [35 in-lbs]	1 Nm [9 in-lbs]
Maximum Moment M_y	10 Nm [89 in-lbs]	2.5 Nm [22 in-lbs]
Maximum Moment M_z	17 Nm [150 in-lbs]	4.25 Nm [38 in-lbs]

^cCapacities are per set of jaws and are not simultaneous

GC-105

2-Jaw Precision Parallel Grippers | Dimensions and Technical Specifications

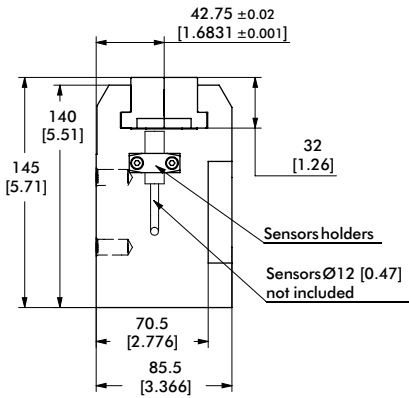
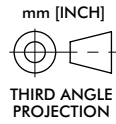
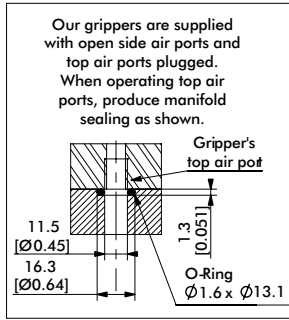

NOTE:

To benefit from safety springs power, on open or on close, gripper must always be operated with "S" for GRIPPING and with "D" for RELEASE.

Drawing hereafter shows gripper gripping at the end of stroke (inlet through "S")

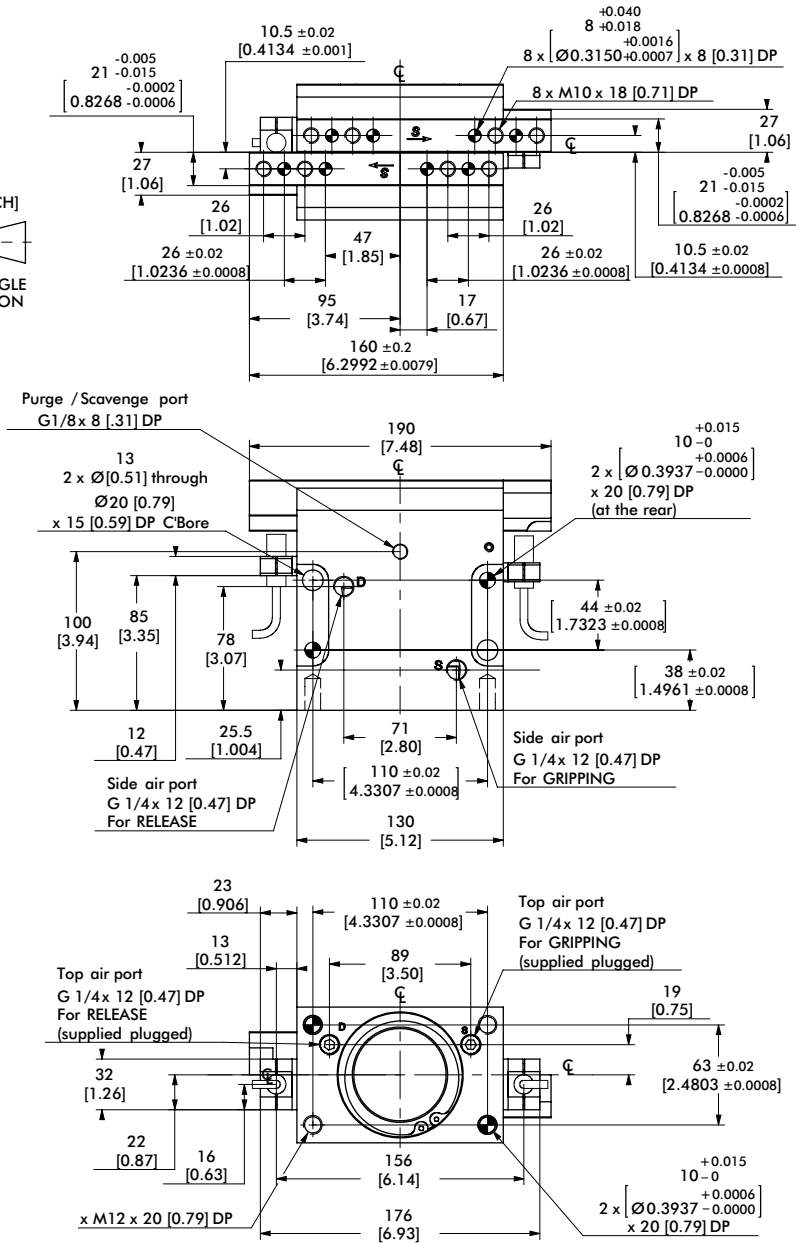

Seal Repair Kits	DGC-105
Buna-N Seal Repair Kit	SLKT-27
Viton® Seal Repair Kit	SLKT-327V

Loading Information

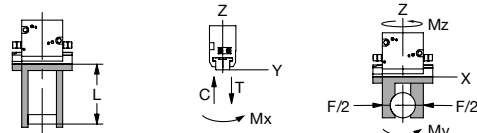
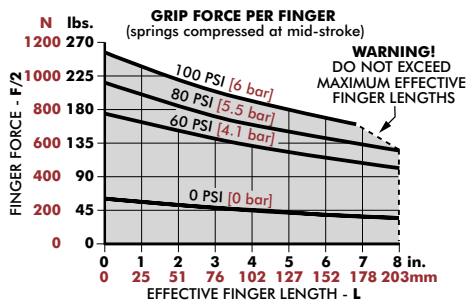

GC-105	Static	Dynamic
Maximum Tensile T	415 N [93 lbs]	83 N [19 lbs]
Maximum Compressive C	455 N [102 lbs]	91 N [20 lbs]
Maximum Moment M_x	8 Nm [71 in-lbs]	2 Nm [18 in-lbs]
Maximum Moment M_y	19 Nm [168 in-lbs]	4.75 Nm [42 in-lbs]
Maximum Moment M_z	40 Nm [354 in-lbs]	10 Nm [89 in-lbs]

*Capacities are per set of jaws and are not simultaneous

DPL SERIES

2-Jaw Precision Parallel Grippers | Features and Benefits | How To Order

Features:

- Robust long stroke, high grip force precision gripper
- Rack and pinion design with double acting pistons
- Shielded design to repel chips and particulates
- Synchronous or non-synchronous jaw operation
- Spring assist option maintains grip in case of air pressure loss
- Multi-position sensing up to 3 locations

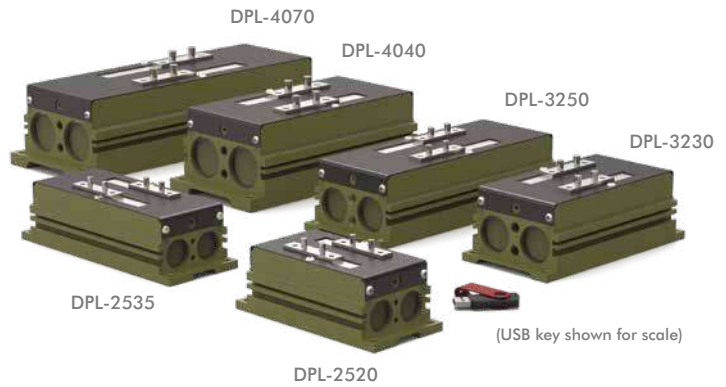

Applications:

- Packaging, pick and place applications
- Long finger gripping applications
- Large and heavy part handling

How To Order

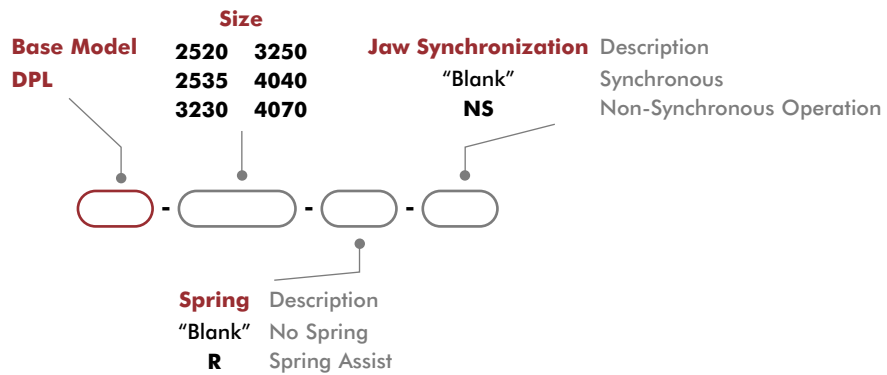

Accessories

Sensor Accessories	Model Numbers	Part Number	Qty/Unit
M8 PNP Magneto Resistive Sensor with Quick Disconnect*	All Models	OHSP-017	1-3
M8 NPN Magneto Resistive Sensor with Quick Disconnect*	All Models	OHSN-017	1-3
M8 PNP Magneto Resistive Sensor (90° barrel) w/Qk. Disc.*	All Models	OHSP-011	1-3
M8 NPN Magneto Resistive Sensor (90° barrel) w/Qk. Disc.*	All Models	OHSN-011	1-3
M8 PNP Inductive Sensor with Quick Disconnect*	2520, 2535, 3230, 3250	OISP-011	1-3
M8 NPN Inductive Sensor with Quick Disconnect*	2520, 2535, 3230, 3250	OISN-011	1-3
M12 PNP Inductive Sensor with Quick Disconnect*	4040, 4070	OISP-017	1-3
M12 NPN Inductive Sensor with Quick Disconnect*	4040, 4070	OISN-017	1-3
Inductive Sensor Mounting Kit (3 Holders + 2 Flags)	See Datasheet		1
M8 Quick Disconnect 2 Meter Cable Length*	All Models	CABL-010	1-3
M8 Quick Disconnect 5 Meter Cable Length*	All Models	CABL-013	1-3
M12 Quick Disconnect 2 Meter Cable Length*	4040, 4070	CABL-014	1-3
M12 Quick Disconnect 5 Meter Cable Length*	4040, 4070	CABL-018	1-3

Pneumatic Accessories	Model Numbers	Part Number	Qty/Unit
Fitting Push-in Straight M5 - 6mm O.D. Tube	2520, 2535	PLFT-037	1-2
Fitting Push-in 90° Elbow M5 - 6mm O.D. Tube	2520, 2535	PLFT-041	1-2
Fitting Push-in Straight G1/8 - 6mm O.D. Tube	3230, 3250, 4040, 4070	PLFT-038	1-2
Fitting Push-in 90° Elbow G1/8 - 6mm O.D. Tube	3230, 3250, 4040, 4070	PLFT-042	1-2

* Sensor and cable sold separately.

2-Jaw Precision Parallel Grippers | Technical Specifications

Specifications	Units	2520	2535	3230
Total Rated Grip Force F @ 100 psi	N [lb]	811 [182]	768 [173]	1359 [306]
Total Stroke	mm [in]	40 [1.57]	70 [2.76]	60 [2.36]
Weight	kg [lbs]	1.38 [3.04]	1.80 [3.97]	2.26 [4.98]
Pressure Range (without springs)	bar [psi]	2-7 [30-100]		
Pressure Range (with springs)	bar [psi]	4-7 [60-100]		
Ingress Protection Class (IP)		IP54		
Displacement	cm ³ [in ³]	39 [2.38]	68 [4.15]	96 [5.86]
Temperature Range	°C [°F]	-20°~80° [-4°~180°]		
Actuation	sec	0.3	0.4	0.4
Accuracy	mm [in]	±0.08 [±0.003]		
Repeatability	mm [in]	±0.025 [±0.0010]		
Valve to Actuate Single Acting		3-way, 2-position		
Valve to Actuate Double Acting		4-way, 2-position		

Specifications	Units	3250	4040	4070
Total Rated Grip Force F @ 100 psi	N [lb]	1306 [294]	2035 [457]	2035 [457]
Total Stroke	mm [in]	100 [3.94]	80 [3.15]	140 [5.51]
Weight	kg [lbs]	3.02 [6.66]	4.30 [9.48]	6.00 [13.23]
Pressure Range (without springs)	bar [psi]	2-7 [30-100]		
Pressure Range (with springs)	bar [psi]	4-7 [60-100]		
Ingress Protection Class (IP)		IP54		
Displacement	cm ³ [in ³]	160 [9.96]	200 [12.20]	350 [21.36]
Temperature Range	°C [°F]	-20°~80° [-4°~180°]		
Actuation	sec	0.5	0.5	0.7
Accuracy	mm [in]	±0.08 [±0.003]		
Repeatability	mm [in]	±0.025 [±0.0010]		
Valve to Actuate Single Acting		3-way, 2-position		
Valve to Actuate Double Acting		4-way, 2-position		

2-Jaw Precision Parallel Grippers | Dimensions and Technical Specifications

Sensor Accessories	2520
Inductive Sensor Mounting Kit (3 holders + 2 flags)	OSMK-099
Seal Repair Kits	2520
Buna-N Seal Repair Kit	SLKT-233
Rear Inlet Seal Repair Kit	SLKT-316
Mounting Accessories	2520
In-line Jaw Mounting Kit	ODPL-001

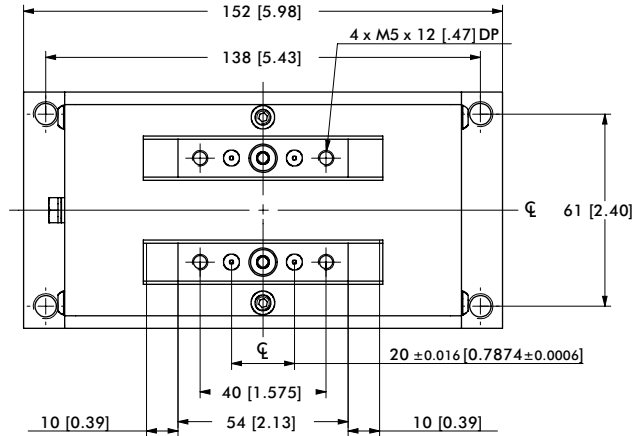
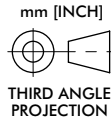
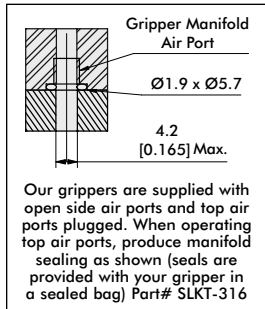

Jaws shown at mid stroke

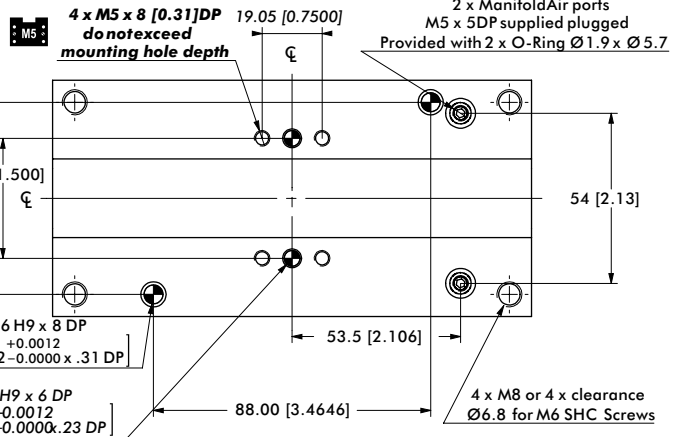
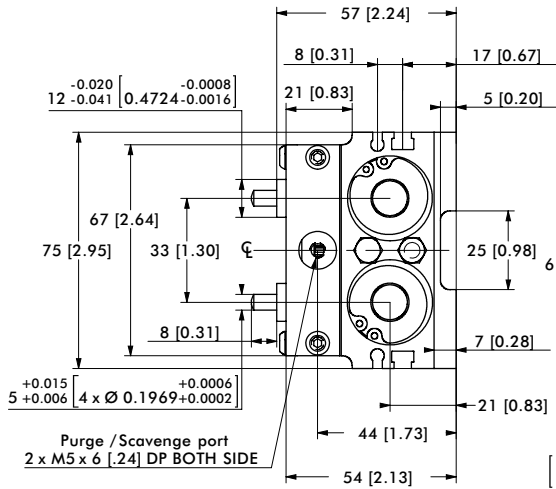
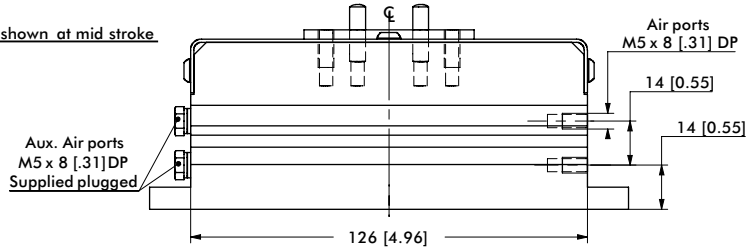

Loading Information

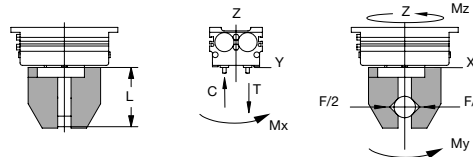
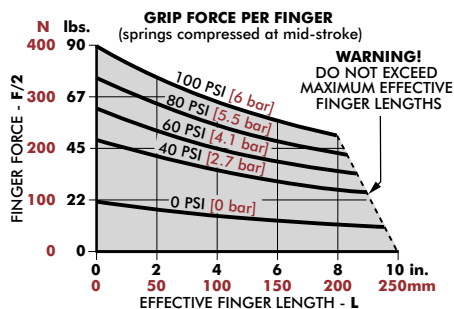

DPL-2520	Static	Dynamic
Maximum Tensile T	222 N [50 lbs]	67 N [15 lbs]
Maximum Compressive C	222 N [50 lbs]	67 N [15 lbs]
Maximum Moment M_x	6 Nm [50 in-lbs]	1 Nm [12 in-lbs]
Maximum Moment M_y	7 Nm [60 in-lbs]	2 Nm [15 in-lbs]
Maximum Moment M_z	6 Nm [50 in-lbs]	1 Nm [12 in-lbs]

*Capacities are per set of jaws and are not simultaneous

2-Jaw Precision Parallel Grippers | Dimensions and Technical Specifications

Sensor Accessories	2535
Inductive Sensor Mounting Kit (3 holders + 2 flags)	OSMK-099
Seal Repair Kits	2535
Buna-N Seal Repair Kit	SLKT-233
Rear Inlet Seal Repair Kit	SLKT-316
Mounting Accessories	2535
In-line Jaw Mounting Kit	ODPL-002

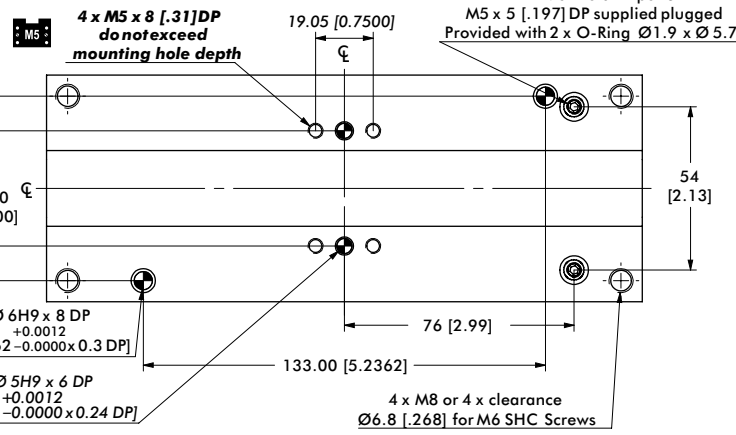
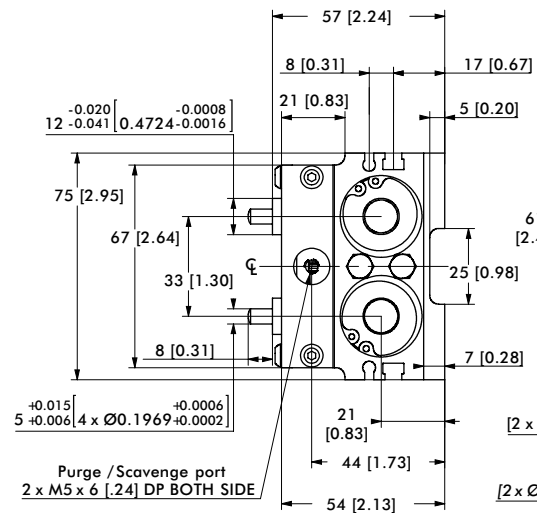
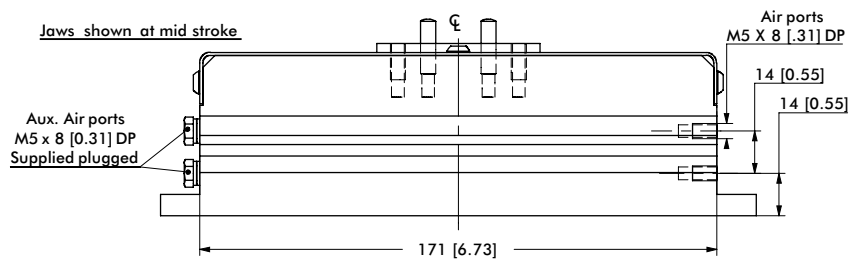
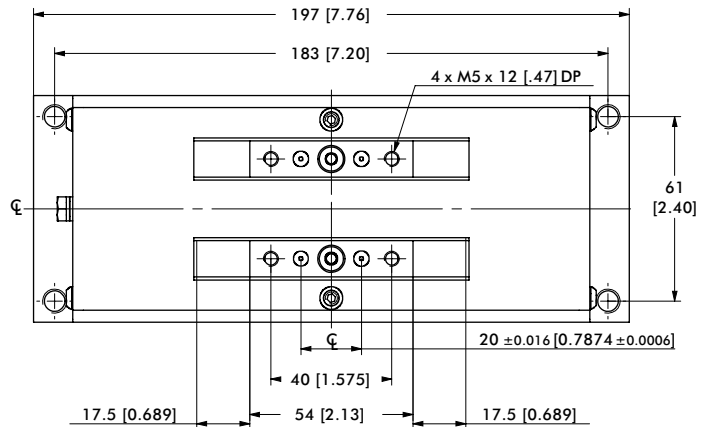
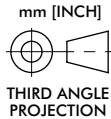
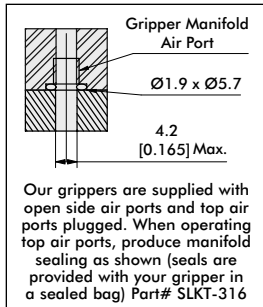

Loading Information

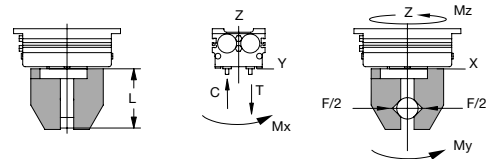
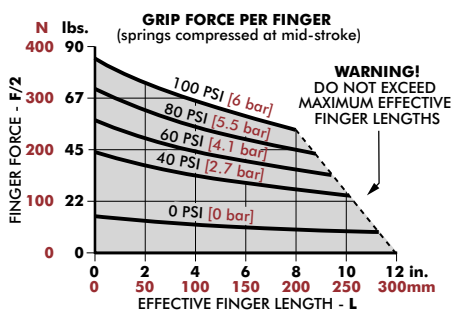

DPL-2335	Static	Dynamic
Maximum Tensile T	267 N [60 lb]	89 N [20 lb]
Maximum Compressive C	267 N [60 lb]	89 N [20 lb]
Maximum Moment M_x	11 Nm [100 in-lb]	3 Nm [25 in-lb]
Maximum Moment M_y	14 Nm [120 in-lb]	3 Nm [30 in-lb]
Maximum Moment M_z	11 Nm [100 in-lb]	3 Nm [25 in-lb]

*Capacities are per set of jaws and are not simultaneous

2-Jaw Precision Parallel Grippers | Dimensions and Technical Specifications

Sensor Accessories	3230
Inductive Sensor Mounting Kit (3 holders + 2 flags)	OSMK-100
Seal Repair Kits	3230
Buna-N Seal Repair Kit	SLKT-234
Rear Inlet Seal Repair Kit	SLKT-316
Mounting Accessories	3230
In-line Jaw Mounting Kit	ODPL-003

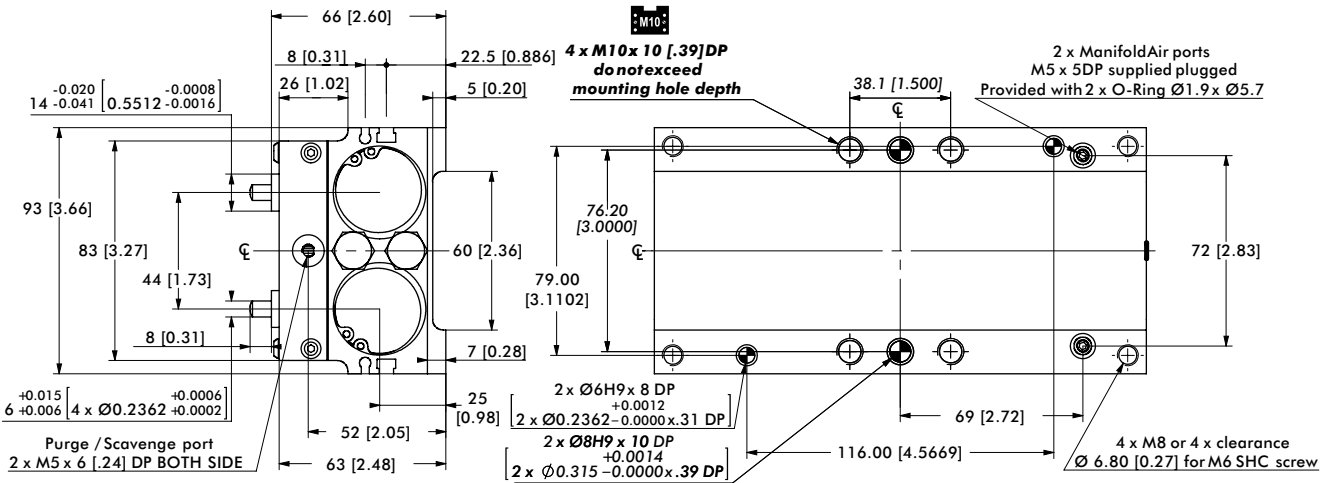
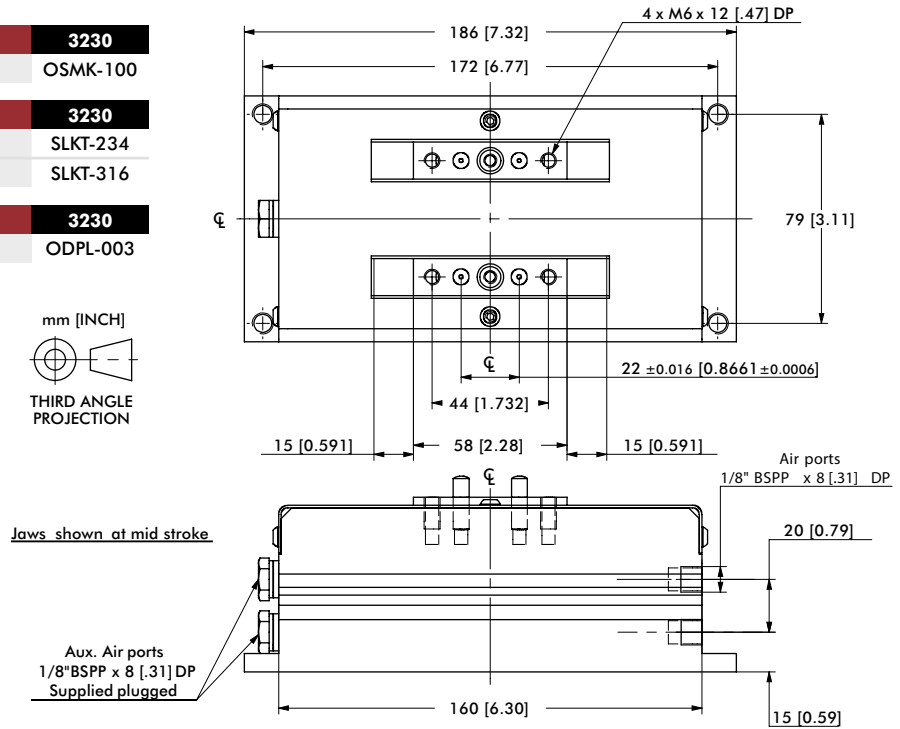
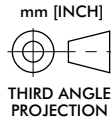
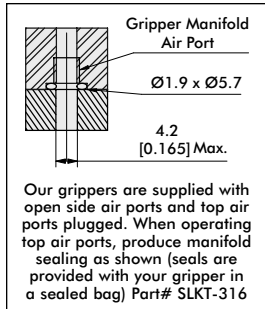

Loading Information

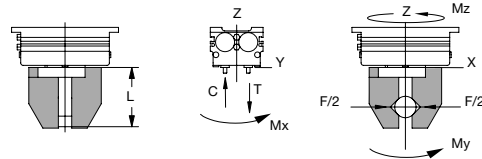
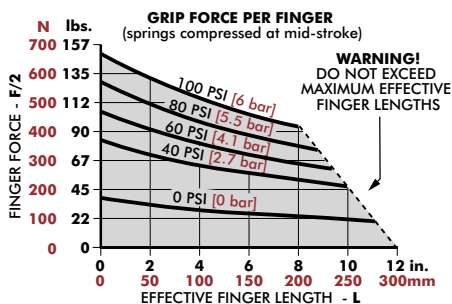

DPL-3230	Static	Dynamic
Maximum Tensile T	1525 N [343 lbs]	270 N [61 lbs]
Maximum Compressive C	1900 N [427 lbs]	270 N [61 lbs]
Maximum Moment M_x	76 Nm [673 in-lbs]	8 Nm [71 in-lbs]
Maximum Moment M_y	227 Nm [2009 in-lbs]	22 Nm [195 in-lbs]
Maximum Moment M_z	120 Nm [1062 in-lbs]	22 Nm [195 in-lbs]

*Capacities are per set of jaws and are not simultaneous

2-Jaw Precision Parallel Grippers | Dimensions and Technical Specifications

Sensor Accessories	3250
Inductive Sensor Mounting Kit (3 holders + 2 flags)	OSMK-100
Seal Repair Kits	3250
Buna-N Seal Repair Kit	SLKT-234
Rear Inlet Seal Repair Kit	SLKT-316
Mounting Accessories	3250
In-line Jaw Mounting Kit	ODPL-004

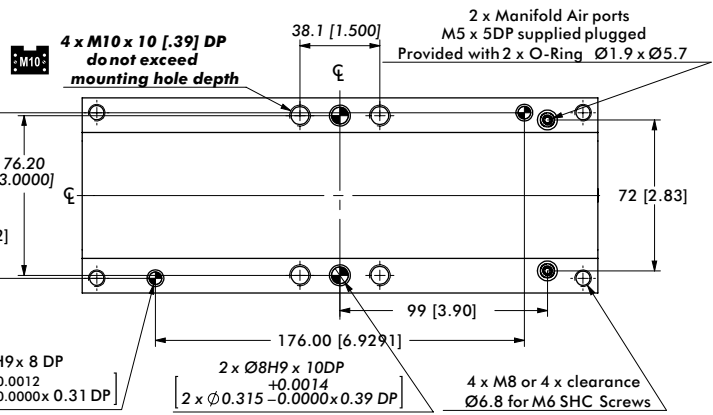
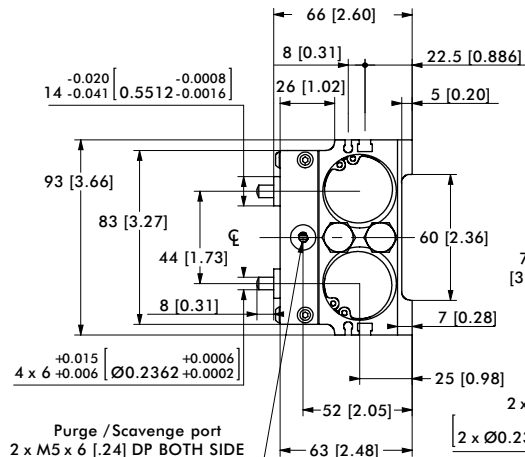
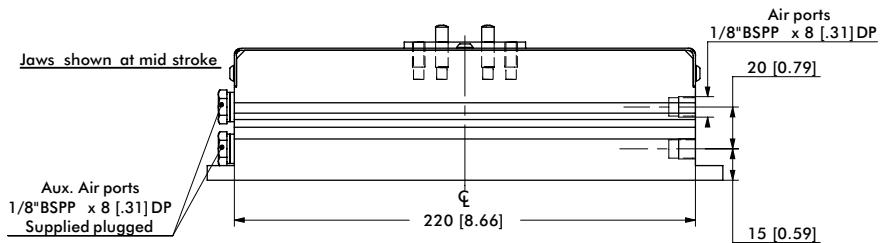
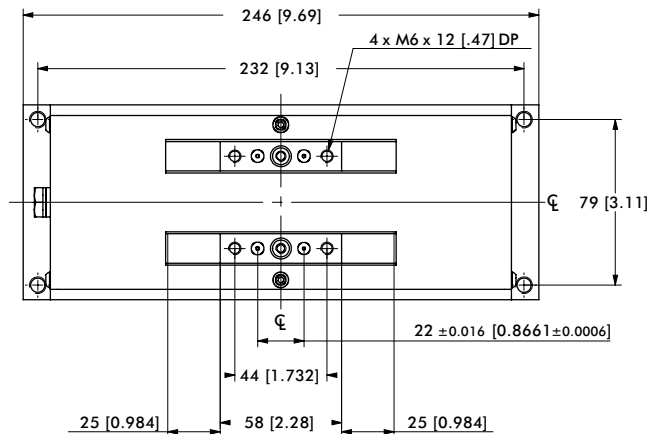
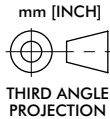
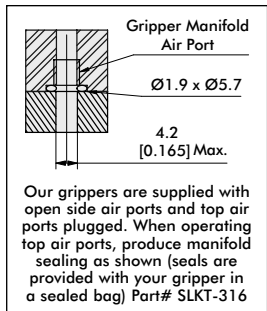

Loading Information

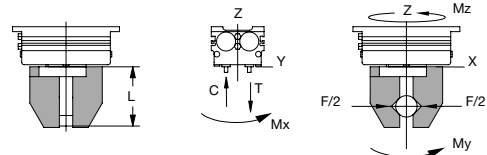
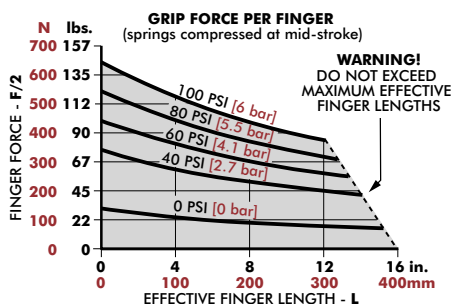

DPL-3250	Static	Dynamic
Maximum Tensile T	1850 N [416 lbs]	260 N [58 lbs]
Maximum Compressive C	2315 N [520 lbs]	260 N [58 lbs]
Maximum Moment M_x	87 Nm [770 in-lbs]	8 Nm [71 in-lbs]
Maximum Moment M_y	350 Nm [3098 in-lbs]	32 Nm [283 in-lbs]
Maximum Moment M_z	190 Nm [1682 in-lbs]	32 Nm [283 in-lbs]

*Capacities are per set of jaws and are not simultaneous

2-Jaw Precision Parallel Grippers | Dimensions and Technical Specifications

Sensor Accessories	4070
Inductive Sensor Mtg Kit (3 holders + 2 flags)	OSMK-101
Seal Repair Kits	4070
Buna-N Seal Repair Kit	SLKT-235
Rear Inlet Seal Repair Kit	SLKT-316
Mounting Accessories	4070
In-line Jaw Mounting Kit	ODPL-006

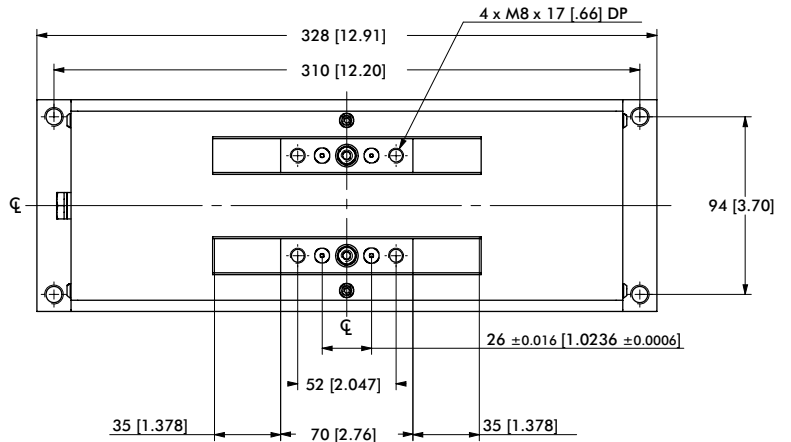
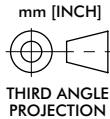
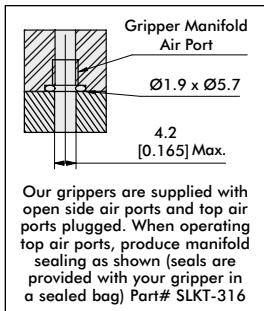

Jaws shown at mid stroke

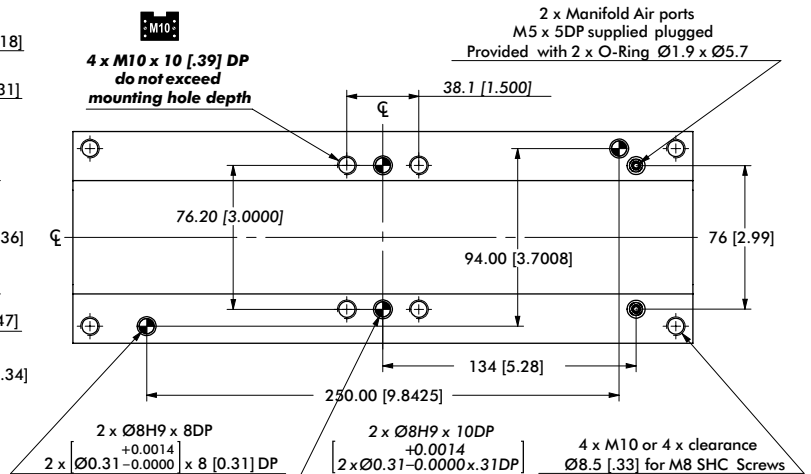
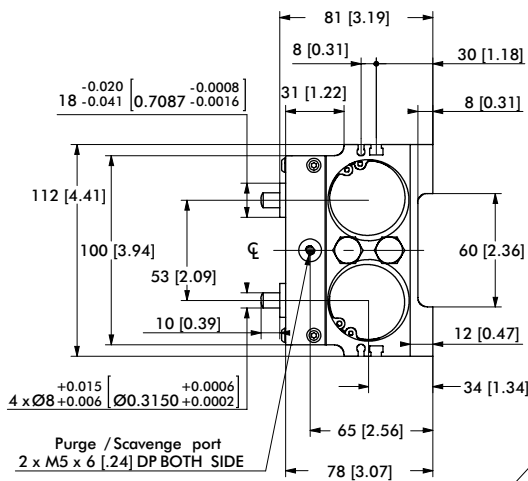
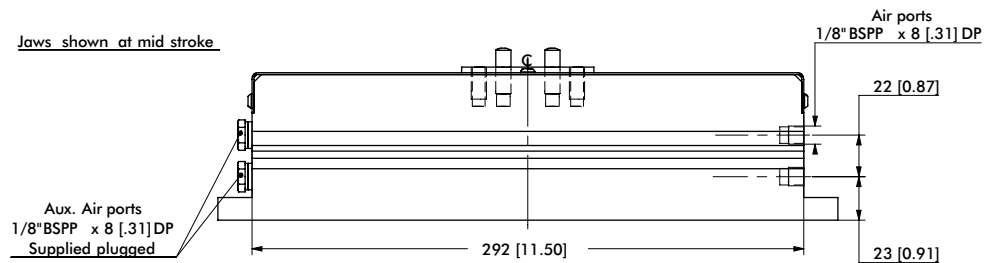

Loading Information

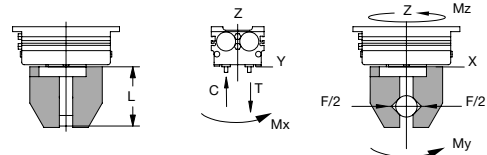
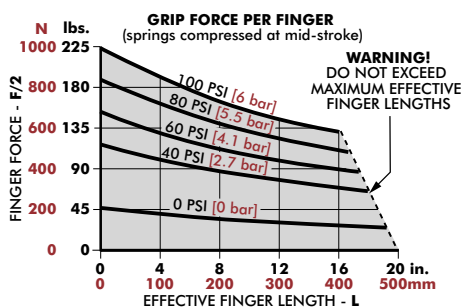

DPL-4070	Static	Dynamic
Maximum Tensile T	2510 N [564 lbs]	400 N [90 lbs]
Maximum Compressive C	3010 N [677 lbs]	400 N [90 lbs]
Maximum Moment M_x	160 Nm [1416 in-lbs]	15 Nm [133 in-lbs]
Maximum Moment M_y	665 Nm [5885 in-lbs]	64 Nm [566 in-lbs]
Maximum Moment M_z	350 Nm [3098 in-lbs]	64 Nm [566 in-lbs]

*Capacities are per set of jaws and are not simultaneous

DPL OPTIONS & ACCESSORIES

2-Jaw Precision Parallel Grippers | Dimensions and Technical Specifications

In-Line Jaw Adapter:

The In-Line Jaw Adapter allows for the simplification of the finger design. It provides for "in-line" alignment of the finger mounting holes. The kit includes 2 interfaces, screws, and dowel kit.

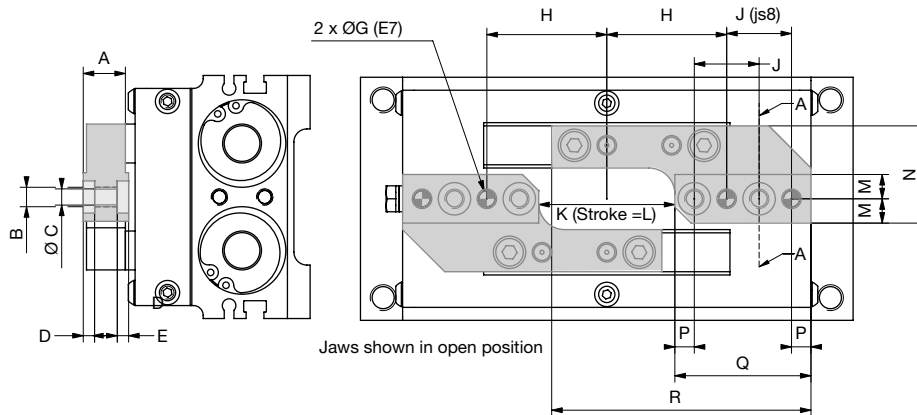

Fingers can be mounted on the accessory from the top (using SHC screws) or from the bottom (using low head SHC screws)

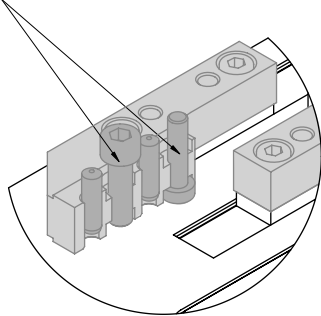

Second direction for mounting the accessory When used with the -R option, it allows to secure for internal or external clamping

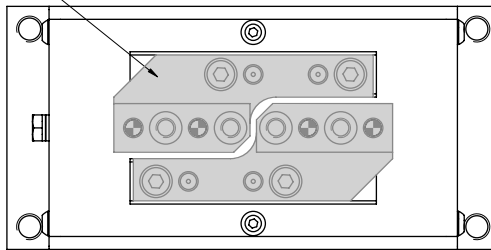

Order #	Use With	A	B	C	D	E	F	G	H	J	K	L	M	N	P	Q	R
ODPL-001	DPL-2520	[0.51] 13	M6	[0.20] 5	[0.14] 3.5	[0.28] 7	M5	[0.20] 5	[1.46] 37	[0.79] 20	[1.65] 42	[1.57] 40	[0.30] 7.5	[1.18] 30	[0.24] 6	[1.65] 42	[3.15] 80
ODPL-002	DPL-2535								[2.05] 52		[2.83] 72	[2.76] 70					[3.44] 87.5
ODPL-003	DPL-3230	[0.59] 15	M8	[0.27] 6.8	[0.12] 3	[0.39] 10	M6	[0.24] 6	[1.97] 50	[0.87] 22	[2.44] 62	[2.36] 60	[0.39] 10	[1.54] 39	[0.31] 8	[1.93] 49	[3.70] 94
ODPL-004	DPL-3250								[2.76] 70		[4.02] 102	[3.94] 100					[4.09] 104
ODPL-005	DPL-4040	[0.83] 21	M10	[0.33] 8.5	[0.20] 5	[0.47] 12	M8	[0.31] 8	[2.48] 63	[1.02] 26	[3.23] 82	[3.15] 80	[0.47] 12	[1.87] 47.5	[0.35] 9	[2.24] 57	[4.45] 113
ODPL-006	DPL-4070								[3.66] 93		[5.59] 142	[5.51] 140					[5.04] 128

DPL OPTIONS & ACCESSORIES

2-Jaw Precision Parallel Grippers | Dimensions and Technical Specifications

Optional Spring Assist (-R):

The safety spring allows the gripper to retain the part should the air supply fail or allows the gripper to be used in single acting mode. The -R option is ideal for internal (ID) or external gripping (OD). The ID or OD will depend on the finger design. The fingers will face towards center of gripper for OD gripping or will face outward for ID gripping.

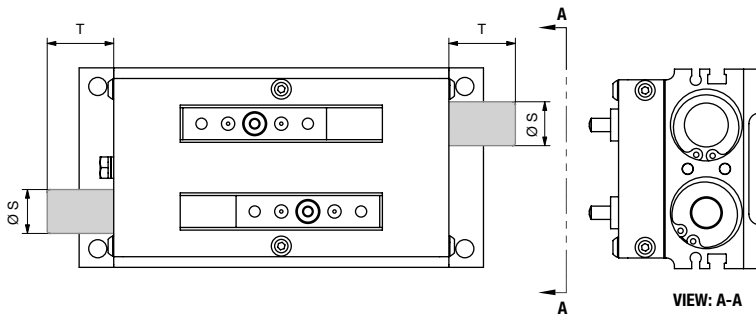

Model #	S	T
DPL-2520-R	[0.65] 16.5	[0.98] 25
DPL-2535-R		[1.18] 30
DPL-3230-R	[0.98] 25	[0.76] 19.3
DPL-3250-R		[0.96] 24.3
DPL-4040-R	[1.10] 28	[1.69] 42.8
DPL-4070-R	[1.16] 29.5	[0.98] 24.8

Inductive Sensors Holder:

Sense up to 3 jaw positions; open jaws, closed jaws, and part present. The kit includes 3 sensor holders and 2 flags. Sensors are not included.

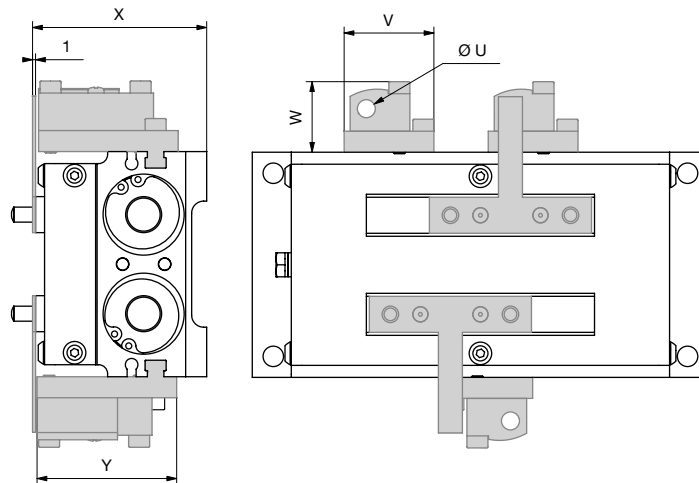

Order #	Use With	U	V	W	X	Y
OSMK-099	DPL-2520	[0.31] 8	[1.18] 30	[0.95] 24	[2.28] 58	[1.83] 46.5
	DPL-2535					
OSMK-100	DPL-3230		[0.87] 22	[0.95] 24	[2.64] 67	[1.97] 50
	DPL-3250					
OSMK-101	DPL-4040	[0.47] 12	[0.87] 22	[1.06] 27	[3.23] 82	[2.26] 57.5
	DPL-4070					

DPP SERIES

2-Jaw Precision Parallel Grippers | Features and Benefits | How To Order

Features:

- Highest precision gripper with excellent part position repeatability
- Zero side play and smooth operation with shielded Dual-V roller bearing design
- Spring assist closed option for increased grip force or maintain grip upon air loss.
- Multiple air port locations simplifies air line routing
- Supports up to four sensing positions of jaws
- Synchronous or non-synchronous jaw operation
- Long life supported with shielded design
- Purge/scavenge ports for clean & harsh environments

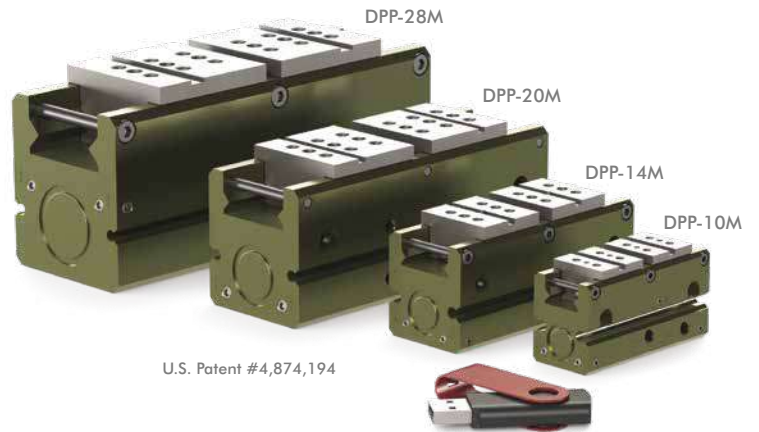

U.S. Patent #4,874,194

(USB key shown for scale)

Applications:

- Delicate part handling, low friction, low pressure applications
- Long finger gripping applications
- Non-synchronous applications requiring independent jaw motion

How To Order

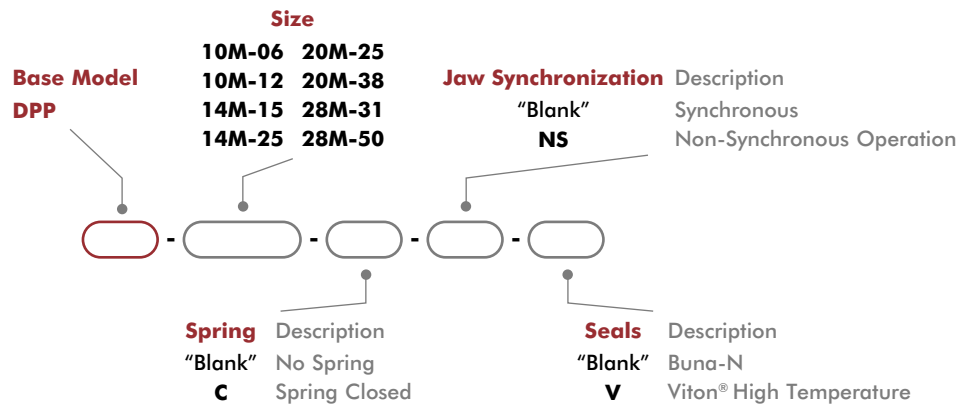

Accessories

Sensor Accessories	Model Numbers	Part Number	Qty/Unit
Inductive Sensor Mounting Kit (Mounts 2 sensors)	10M, 14M	OSMK-119	1-2
Inductive Sensor Mounting Kit (Mounts 2 sensors)	20M, 28M	OSMK-120	1-2
NPN Inductive Sensor (with Qk. Disc.)*	All Models	OISN-014	1-4
PNP Inductive Sensor (with Qk. Disc.)*	All Models	OISP-014	1-4
NPN Magneto Resistive Sensor (with Qk. Disc.)*†	All Models	OHSN-017	1-4
PNP Magneto Resistive Sensor (with Qk. Disc.)*†	All Models	OHSP-017	1-4
NPN Magneto Resistive Sensor 90° (with Qk. Disc.)*†	All Models	OHSN-011	1-4
PNP Magneto Resistive Sensor 90° (with Qk. Disc.)*†	All Models	OHSP-011	1-4
Quick Disconnect Cable (2 meters long)*	All Models	CABL-010	1-4
Quick Disconnect Cable (5 meters long)*	All Models	CABL-013	1-4
Pneumatic Accessories	Model Numbers	Part Number	Qty/Unit
Adjustable Flow Control-M3 Elbow-3MM OD Tube Push-in Style	10M, 14M	VLVF-018	1-2
Adjustable Flow Control-M5 Elbow-6MM OD Tube Push-in Style	20M, 28M	VLVF-008	1-2
Fail Safe Valve - M5	All Models	OFSV-004	1

*Sensor and cable sold separately. †Piston magnet standard.

2-Jaw Precision Parallel Grippers | Technical Specifications

Specifications	Units	10M-6	10M-12	14M-15	14M-25
Total Rated Grip Force F @ 100 psi [7 bar]*	N [lb]	120 [27]		227 [51]	214 [48]
Total Stroke	mm [in]	6.4 [0.25]	12.7 [0.50]	15.9 [0.63]	25.4 [1.00]
Weight	kg [lbs]	0.16 [0.35]	0.20 [0.45]	0.48 [1.05]	0.57 [1.25]
Pressure Range (without spring)	bar [psi]	0.3-7 [5-100]			
Pressure Range (with spring)	bar [psi]	1.4-7 [20-100]		3.4-7 [50-100]	
Ingress Protection Class (IP)		IP43			
Displacement	cm ³ [in ³]	0.5 [0.032]	1.1 [0.065]	2.5 [0.156]	4.1 [0.249]
Temperature Range (Buna-N seals)	°C [°F]	-35°~80° [-30°~180°]			
Temperature Range (Viton® seals)	°C [°F]	-30°~120° [-20°~250°]			
Actuation (without spring)	sec	0.10	0.11	0.15	0.19
Actuation (with spring)	sec	0.11	0.12	0.16	0.20
Accuracy	mm [in]	±0.03 [±0.001]			
Repeatability	mm [in]	±0.01 [±0.0005]			
Valve to Actuate Single Acting		3-way, 2-position			
Valve to Actuate Double Acting		4-way, 2-position			

*With springs

Specifications	Units	20M-25	20M-38	28M-31	28M-50
Total Rated Grip Force F @ 100 psi [7 bar]*	N [lb]	458 [103]	449 [101]	912 [205]	934 [210]
Total Stroke	mm [in]	25.4 [1.00]	38.1 [1.50]	31.8 [1.50]	50.8 [2.00]
Weight	kg [lbs]	1.02 [2.25]	1.41 [3.10]	2.06 [4.55]	2.83 [6.25]
Pressure Range (without spring)	bar [psi]	0.3-7 [5-100]			
Pressure Range (with spring)	bar [psi]	2.8-7 [40-100]	2.1-7 [30-100]	2.1-7 [30-100]	2.8-7 [40-100]
Ingress Protection Class (IP)		IP43			
Displacement	cm ³ [in ³]	8.5 [0.519]	12.8 [0.779]	20.4 [1.243]	32.6 [1.998]
Temperature Range (Buna-N seals)	°C [°F]	-35°~80° [-30°~180°]			
Temperature Range (Viton® seals)	°C [°F]	-30°~120° [-20°~250°]			
Actuation (without spring)		0.20	0.24	0.19	0.23
Actuation (with spring)		0.22	0.29	0.25	0.30
Accuracy	mm [in]	±0.03 [±0.001]			
Repeatability	mm [in]	±0.01 [±0.0005]			
Valve to Actuate Single Acting		3-way, 2-position			
Valve to Actuate Double Acting		4-way, 2-position			

*With springs

DPP-10M-06, 10M-12



2-Jaw Precision Parallel Grippers | Dimensions and Technical Specifications

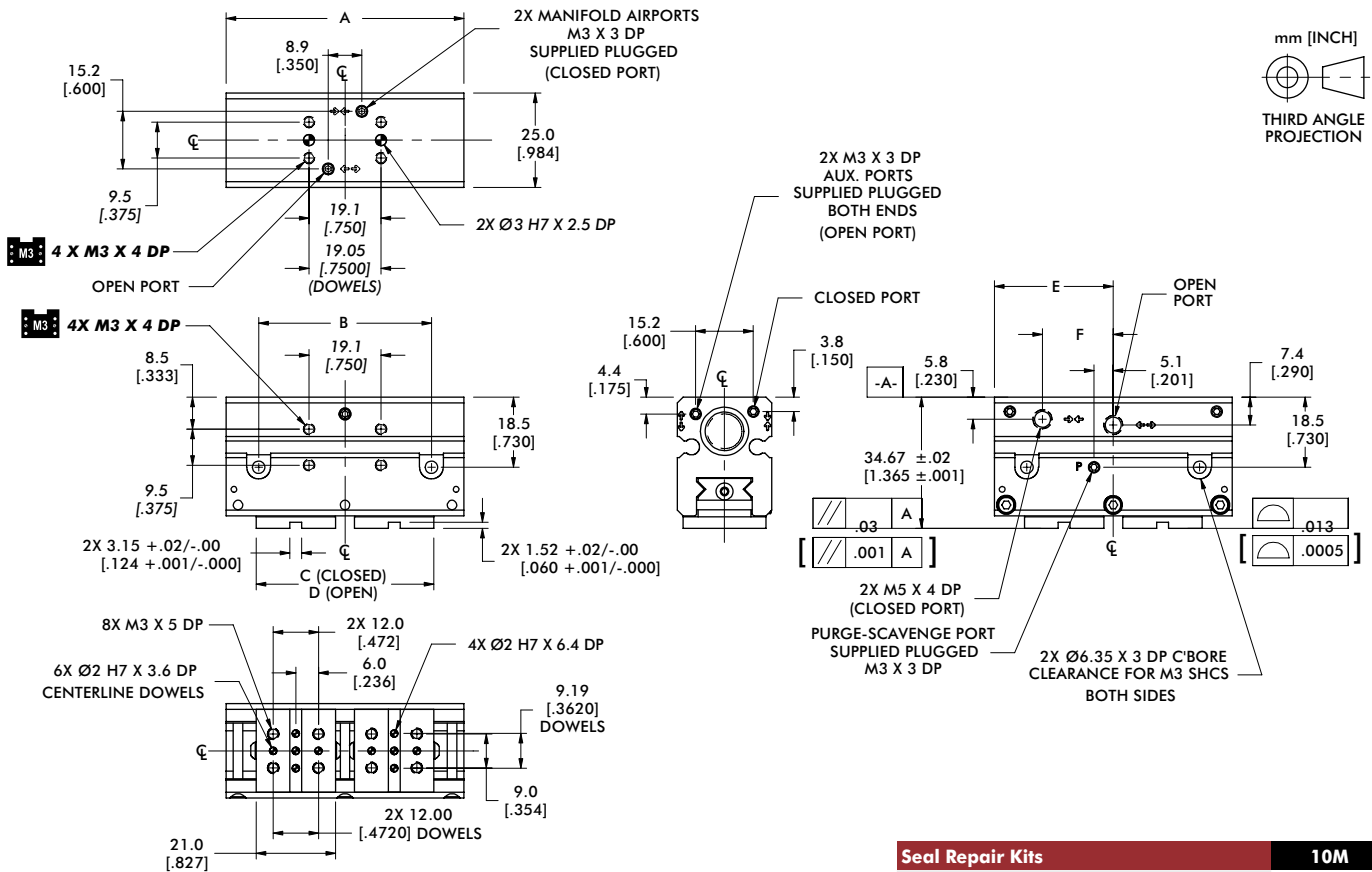

Model	A	B	C	D	E	F
DPP-10M-06	62.9 [2.475]	45.7 [1.800]	47 [1.85]	53 [2.10]	31.4 [1.238]	18.7 [0.738]
DPP-10M-12	73.7 [2.900]	53.3 [2.100]	49 [1.93]	62 [2.43]	36.8 [1.450]	24.1 [0.950]

Dimensions in mm [in]

Seal Repair Kits	10M
Buna-N Seal Repair Kit	SLKT-343
Viton® Seal Repair Kit	SLKT-343V
Manifold Seal Kit (Viton® only)	SLKT-241V

Loading Information

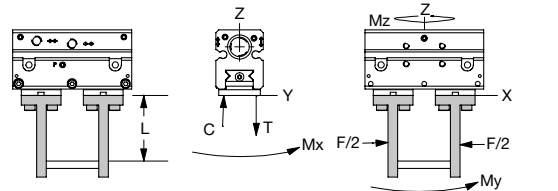
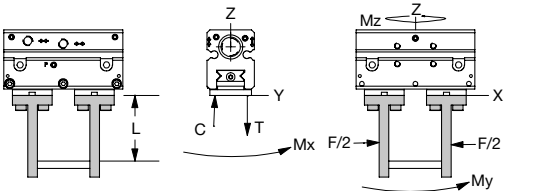
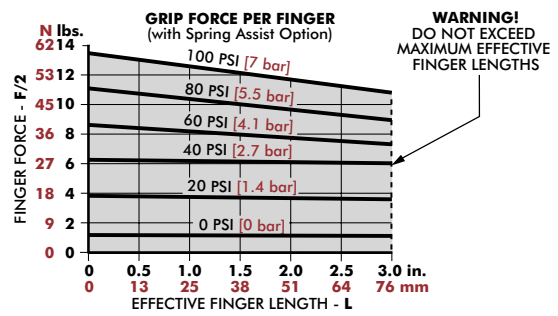
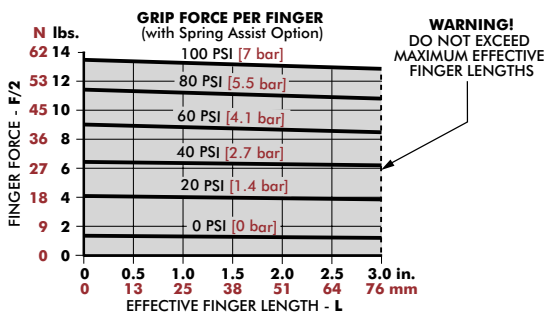

DPP-10M-06	Static	Dynamic
Maximum Tensile T	267 N [60 lbs]	89 N [20 lbs]
Maximum Compressive C	267 N [60 lbs]	89 N [20 lbs]
Maximum Moment M_x	4.0 Nm [35 in-lbs]	1.4 Nm [12 in-lbs]
Maximum Moment M_y	5.6 Nm [50 in-lbs]	1.9 Nm [17 in-lbs]
Maximum Moment M_z	4.0 Nm [35 in-lbs]	1.4 Nm [12 in-lbs]

*Capacities are per set of jaws and are not simultaneous

DPP-10M-12	Static	Dynamic
Maximum Tensile T	311 N [70 lbs]	102 N [23 lbs]
Maximum Compressive C	311 N [70 lbs]	102 N [23 lbs]
Maximum Moment M_x	5.6 Nm [50 in-lbs]	1.9 Nm [17 in-lbs]
Maximum Moment M_y	7.3 Nm [65 in-lbs]	2.5 Nm [22 in-lbs]
Maximum Moment M_z	5.6 Nm [50 in-lbs]	1.9 Nm [17 in-lbs]

*Capacities are per set of jaws and are not simultaneous

2-Jaw Precision Parallel Grippers | Dimensions and Technical Specifications

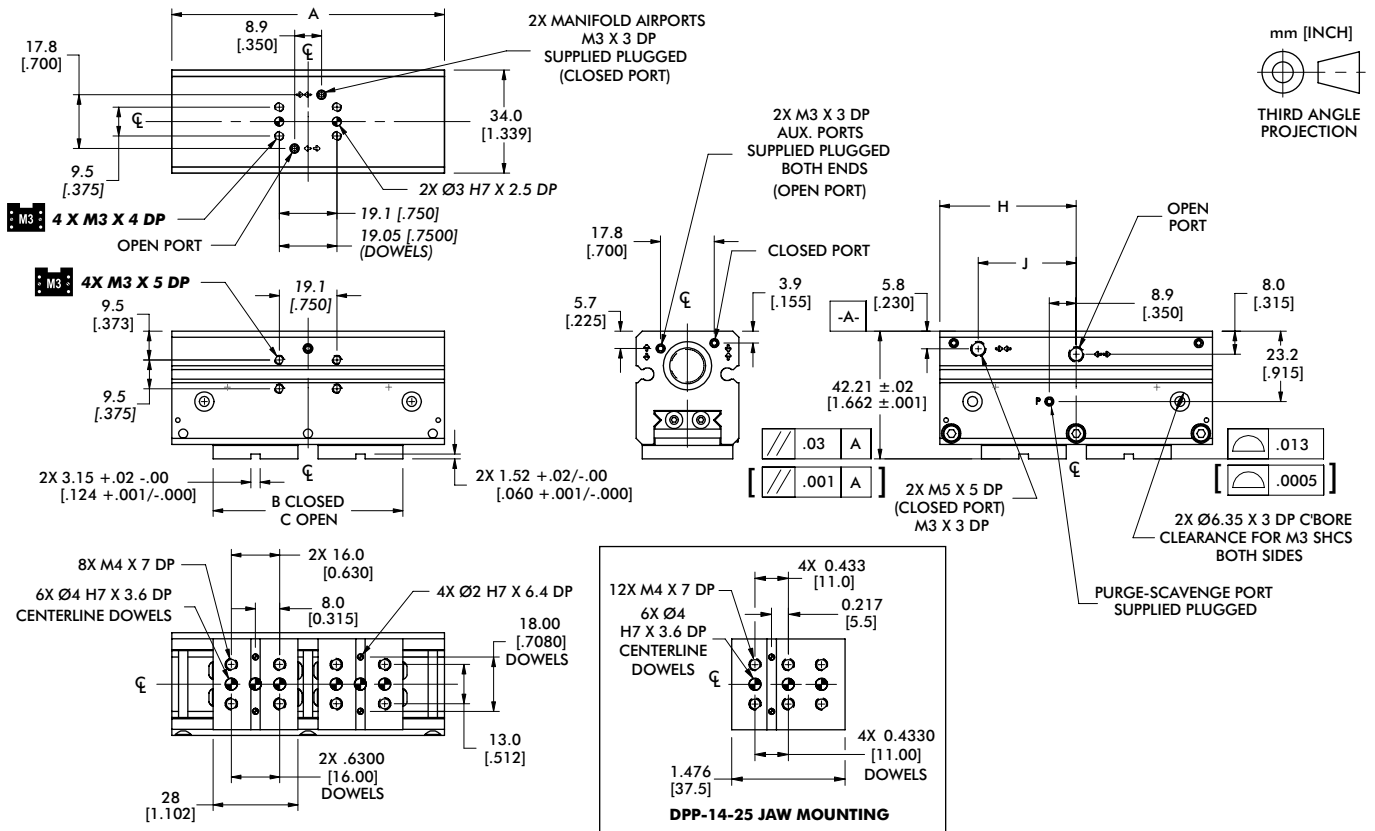

Model	A	B	C	D	E
DPP-14M-15	90.2 [3.550]	63 [2.47]	79 [3.10]	45.1 [1.775]	32.4 [1.275]
DPP-14M-25	118.7 [4.675]	82 [3.23]	107 [4.23]	59.4 [2.338]	46.7 [1.838]

Dimensions in mm [in]

Seal Repair Kits	14M
Buna-N Seal Repair Kit	SLKT-344
Viton® Seal Repair Kit	SLKT-344V
Manifold Seal Kit (Viton® only)	SLKT-241V

Loading Information

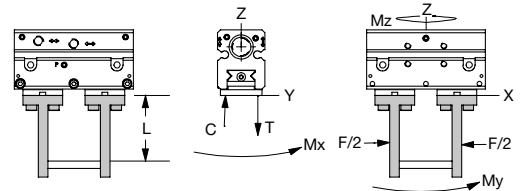
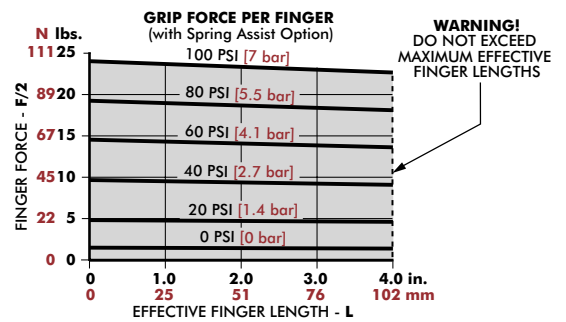
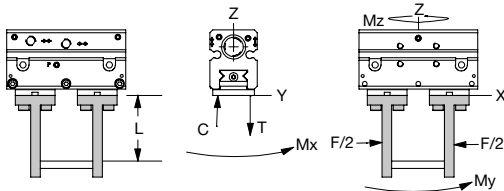
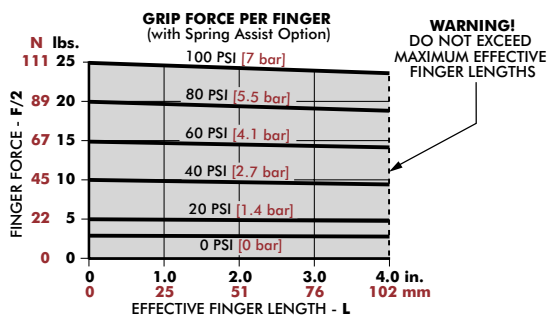

DPP-14M-15	Static	Dynamic
Maximum Tensile T	556 N [125 lbs]	187 N [42 lbs]
Maximum Compressive C	556 N [125 lbs]	187 N [42 lbs]
Maximum Moment M_x	9.0 Nm [80 in-lbs]	3.1 Nm [27 in-lbs]
Maximum Moment M_y	12 Nm [105 in-lbs]	4.0 Nm [35 in-lbs]
Maximum Moment M_z	9.0 Nm [80 in-lbs]	3.1 Nm [27 in-lbs]

Capacities are per set of jaws and are not simultaneous

DPP-14M-25	Static	Dynamic
Maximum Tensile T	734 N [165 lbs]	245 N [55 lbs]
Maximum Compressive C	734 N [165 lbs]	245 N [55 lbs]
Maximum Moment M_x	11 Nm [100 in-lbs]	3.7 Nm [33 in-lbs]
Maximum Moment M_y	14 Nm [125 in-lbs]	4.7 Nm [42 in-lbs]
Maximum Moment M_z	11 Nm [100 in-lbs]	3.7 Nm [33 in-lbs]

Capacities are per set of jaws and are not simultaneous

DPP-20M-25, 20M-38



2-Jaw Precision Parallel Grippers | Dimensions and Technical Specifications

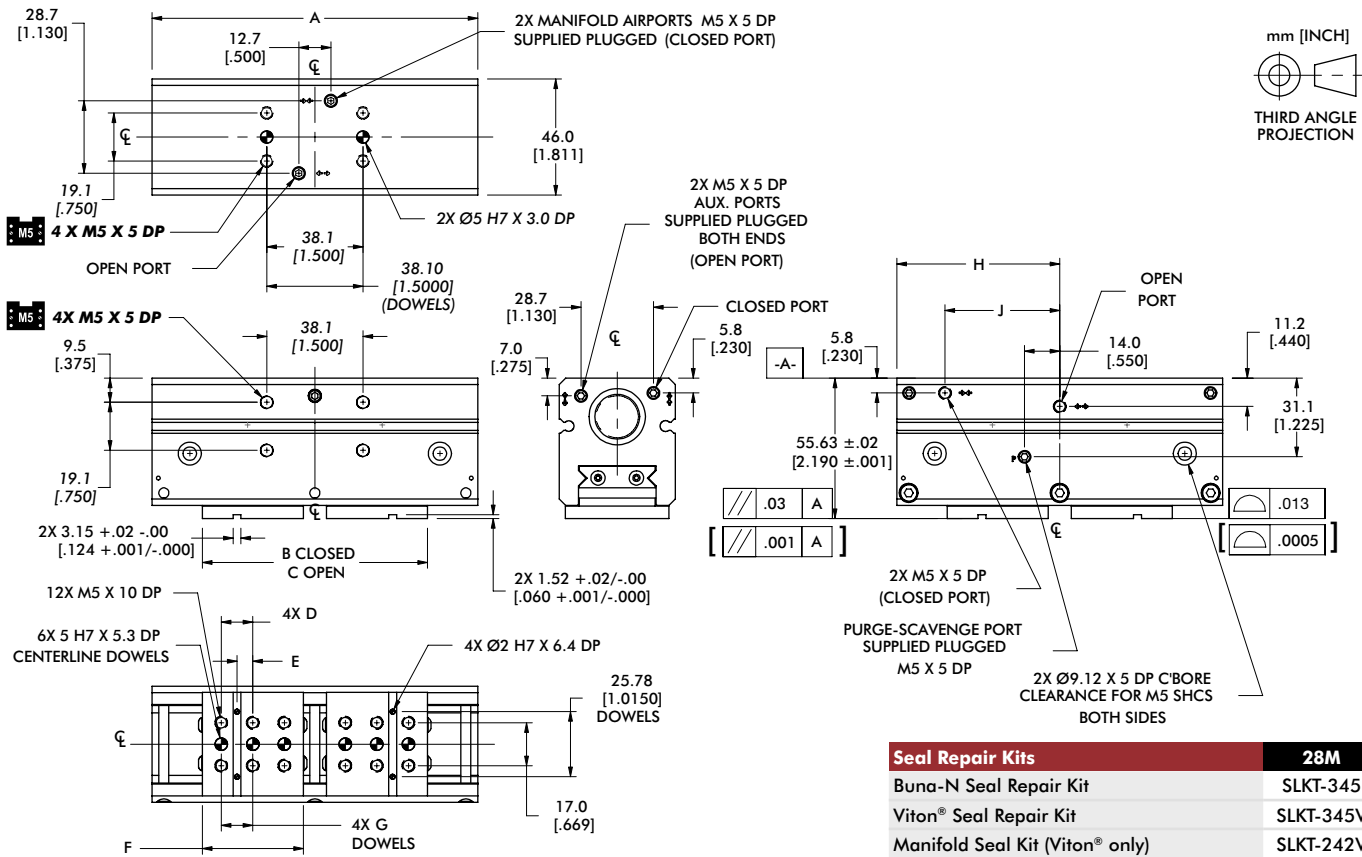

Seal Repair Kits	28M
Buna-N Seal Repair Kit	SLKT-345
Viton® Seal Repair Kit	SLKT-345V
Manifold Seal Kit (Viton® only)	SLKT-242V

Model	A	B	C	D	E	F	G	H	J
DPP-20M-25	129.0 [5.080]	89 [3.51]	115 [4.51]	12.5 [0.492]	6.2 [0.246]	40.0 [1.575]	12.50 [0.4920]	64.5 [2.540]	45.5 [1.790]
DPP-20M-38	175.5 [6.910]	123 [4.85]	161 [6.35]	16.0 [0.630]	8.0 [0.315]	58.0 [2.283]	16.00 [0.6300]	87.8 [3.455]	68.7 [2.705]

Dimensions in mm [in]

Loading Information

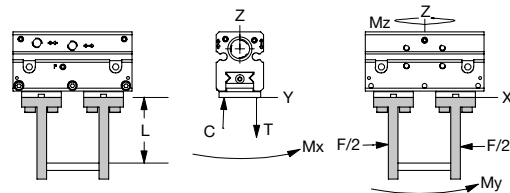
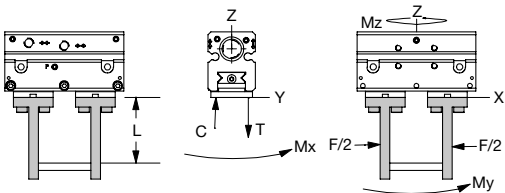
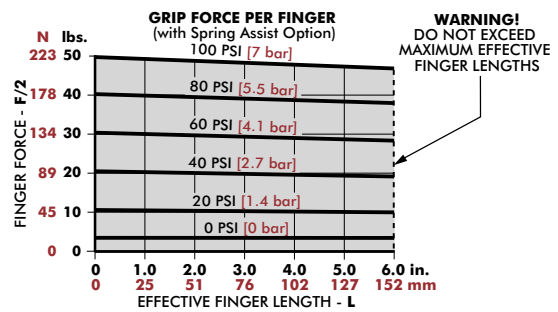
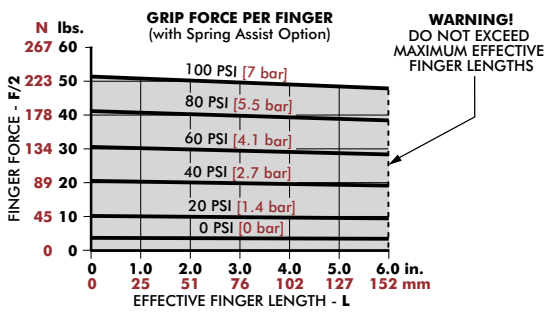

DPP-20M-25	Static	Dynamic
Maximum Tensile T	667 N [150 lbs]	222 N [50 lbs]
Maximum Compressive C	667 N [150 lbs]	222 N [50 lbs]
Maximum Moment M_x	34 Nm [300 in-lbs]	11 Nm [100 in-lbs]
Maximum Moment M_y	40 Nm [350 in-lbs]	13 Nm [117 in-lbs]
Maximum Moment M_z	34 Nm [300 in-lbs]	11 Nm [100 in-lbs]

DPP-20M-38	Static	Dynamic
Maximum Tensile T	890 N [200 lbs]	298 N [67 lbs]
Maximum Compressive C	890 N [200 lbs]	298 N [67 lbs]
Maximum Moment M_x	45 Nm [400 in-lbs]	15 Nm [133 in-lbs]
Maximum Moment M_y	51 Nm [450 in-lbs]	17 Nm [150 in-lbs]
Maximum Moment M_z	45 Nm [400 in-lbs]	15 Nm [133 in-lbs]

[†]Capacities are per set of jaws and are not simultaneous

[†]Capacities are per set of jaws and are not simultaneous

2-Jaw Precision Parallel Grippers | Dimensions and Technical Specifications

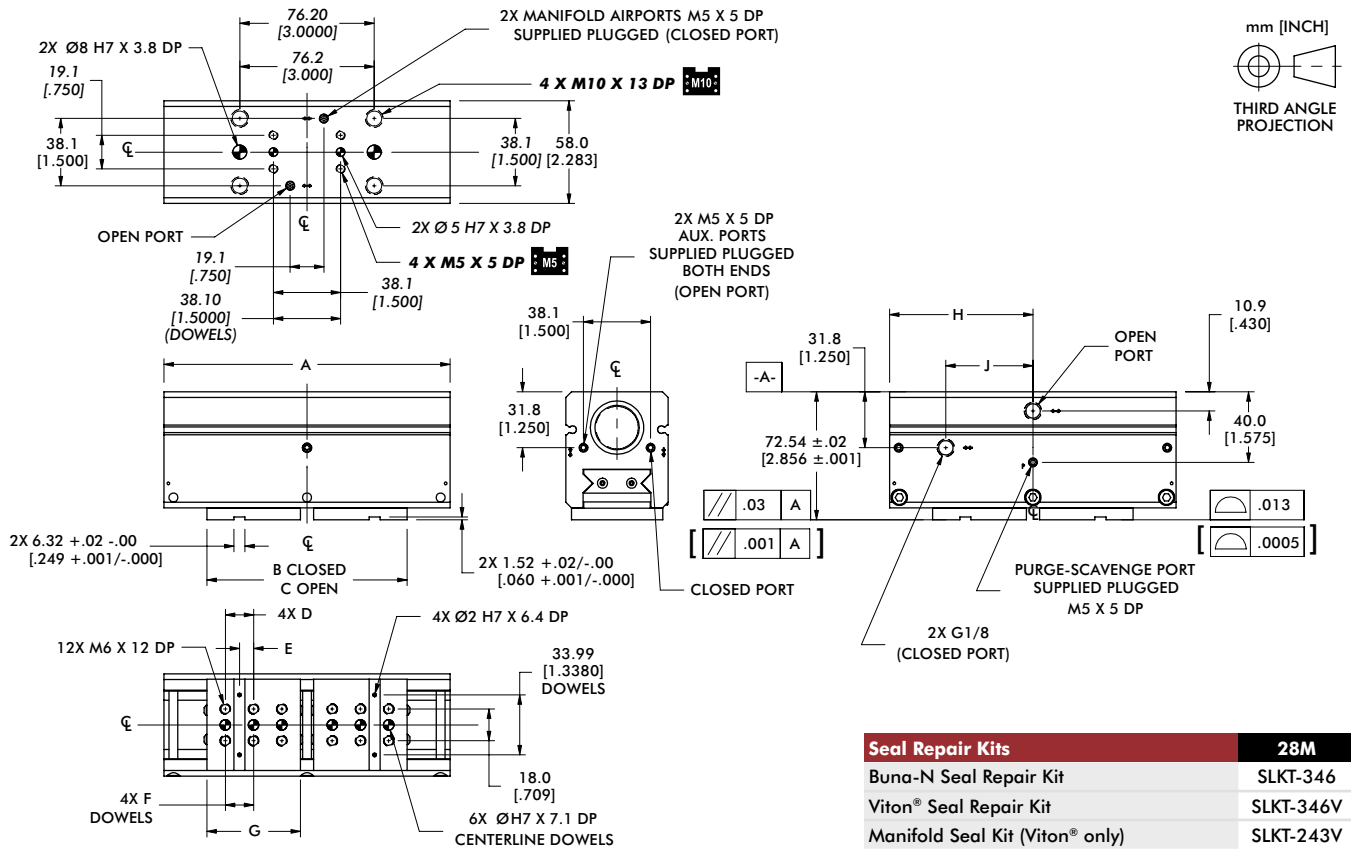

Seal Repair Kits	28M
Buna-N Seal Repair Kit	SLKT-346
Viton® Seal Repair Kit	SLKT-346V
Manifold Seal Kit (Viton® only)	SLKT-243V

Model	A	B	C	D	E	F	G	H	J
DPP-28M-31	162.3 [6.390]	114 [4.47]	145 [5.72]	16.0 [0.630]	8.0 [0.315]	16.00 [0.6300]	53.0 [2.087]	81.2 [3.195]	49.4 [1.945]
DPP-28M-50	221.5 [8.720]	153 [6.04]	204 [8.04]	25.0 [0.984]	12.5 [0.492]	25.00 [0.9840]	73.0 [2.874]	110.7 [4.360]	79.0 [3.110]

Dimensions in mm [in]

Loading Information

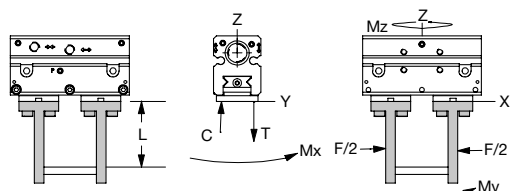
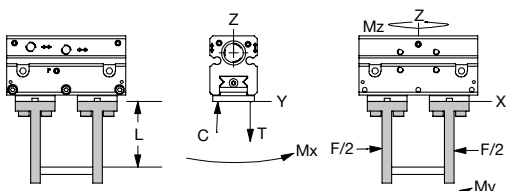
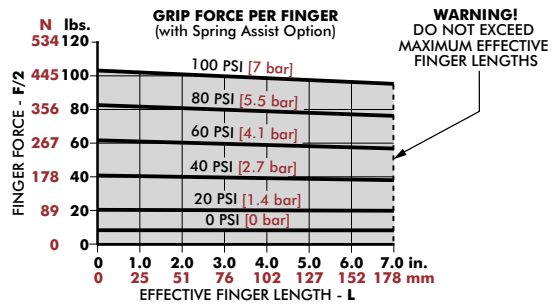
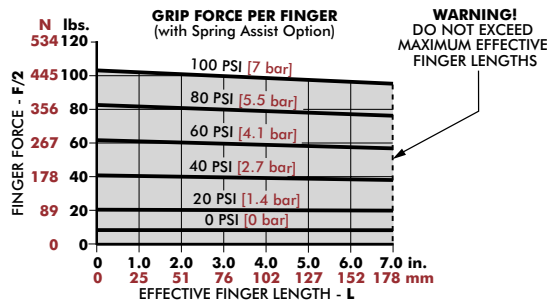

DPP-28M-31	Static	Dynamic
Maximum Tensile T	1001 N [225 lbs]	334 N [75 lbs]
Maximum Compressive C	1001 N [225 lbs]	334 N [75 lbs]
Maximum Moment M_x	64 Nm [570 in-lbs]	21 Nm [190 in-lbs]
Maximum Moment M_y	77 Nm [685 in-lbs]	26 Nm [228 in-lbs]
Maximum Moment M_z	64 Nm [570 in-lbs]	21 Nm [190 in-lbs]

DPP-28M-50	Static	Dynamic
Maximum Tensile T	1379 N [310 lbs]	458 N [103 lbs]
Maximum Compressive C	1379 N [310 lbs]	458 N [103 lbs]
Maximum Moment M_x	89 Nm [785 in-lbs]	30 Nm [262 in-lbs]
Maximum Moment M_y	106 Nm [940 in-lbs]	35 Nm [313 in-lbs]
Maximum Moment M_z	89 Nm [785 in-lbs]	30 Nm [262 in-lbs]

*Capacities are per set of jaws and are not simultaneous

*Capacities are per set of jaws and are not simultaneous

RP-P SERIES

2-Jaw Precision Parallel Grippers | Features and Benefits | How To Order

Features:

- Precision gripper with excellent part position repeatability
- Rack and pinion design for precise jaw synchronization
- Low friction and smooth operation with Dual-V roller bearings
- Maintenance free lubricated cylinder and drive mechanism
- Zero side play and maximum jaw support with preloaded bearings
- Supports up to two sensing positions

Applications:

- Delicate part handling applications
- Highly repeatable and precise gripping
- Clean application environments



How To Order

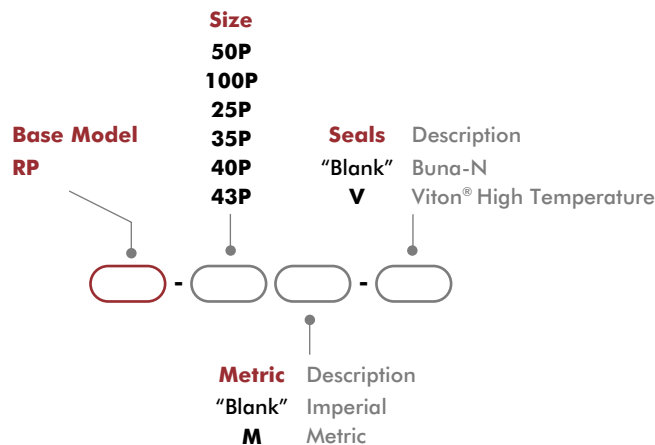

Accessories

Sensor Accessories	Model Numbers	Part Number	Qty/Unit
3mm NPN Inductive Sensor with Quick Disconnect*	RP-50P	OISN-019	1-2
3mm PNP Inductive Sensor with Quick Disconnect*	RP-50P	OISP-019	1-2
4mm NPN Inductive Sensor with Quick Disconnect*	RP-100P, -25P, RP-50P, -110P, -25P	OISN-014	1-2
4mm PNP Inductive Sensor with Quick Disconnect*	RP-100P, -25P, RP-50P, -110P, -25P	OISP-014	1-2
Inductive Sensor Mounting Kit for (mounts 2 sensors)	See Datasheet		1
Quick Disconnect 2 Meter Cable Length*	All Models	CABL-010	1-2
Quick Disconnect 5 Meter Cable Length*	All Models	CABL-013	1-2

Pneumatic Accessories	Model Numbers	Part Number	Qty/Unit
Fail Safe Valve (Imperial)	RP-50P, -110P, -25P	OFSV-001	1
Fail Safe Valve (Metric)	RP-50P, -110P, -25P	OFSV-004	1
Fail Safe Valve (Imperial)	RP-35P, -40P, -43P	OFSV-002	1
Fail Safe Valve (Metric)	RP-50P, -110P, -25P	OFSV-005	1
Stroke Limited Opening Valve (LTD)	RP-35P, -40P, -43P	OLTD-001	1
Stroke Limited Opening Valve (LTD)	RP-50P, -110P, -25P	OLTD-002	1

*Sensor and cable sold separately.

2-Jaw Precision Parallel Grippers | Technical Specifications

Specifications	Units	50P	100P	25P	35P	40P	43P
Total Rated Grip Force F @ 100 psi [7 bar]	N [lb]	107 [24]	160 [36]	356 [80]	778 [175]	890 [200]	2224 [500]
Total Stroke	mm [in]	12.7 [0.50]	25.4 [1.00]	28.7 [1.13]	25.4 [1.00]	50.8 [2.00]	76.2 [3.00]
Weight	kg [lbs]	0.14 [0.31]	0.23 [0.50]	0.45 [1.0]	1.6 [3.5]	2.7 [6.0]	7.3 [16]
Pressure Range	bar [psi]	0.3-7 [5-100]					
Ingress Protection Class (IP)		IP 33					
Displacement	cm ³ [in ³]	1.64 [0.100]	3.6 [0.220]	8.2 [0.500]	17.0 [1.036]	28.0 [1.710]	120.6 [7.360]
Temperature Range (Buna-N seals)	°C [°F]	-35°~80° [-30°~180°]					
Temperature Range (Viton® seals)	°C [°F]	-30°~120° [-20°~250°]					
Actuation (open/close)	sec	0.14	0.18	0.20	0.33	0.39	0.59
Accuracy	mm [in]	±0.03 [±0.001]				±0.05 [±0.002]	
Repeatability	mm [in]	±0.01 [±0.0005]				±0.03 [±0.001]	
Valve to Actuate Double Acting		4-way, 2-position					

RP-50P

2-Jaw Precision Parallel Grippers | Dimensions and Technical Specifications

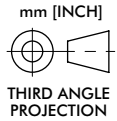
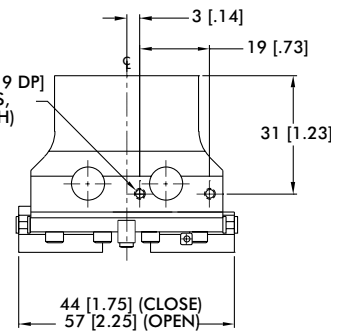
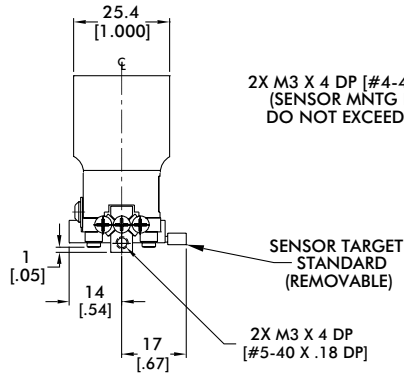
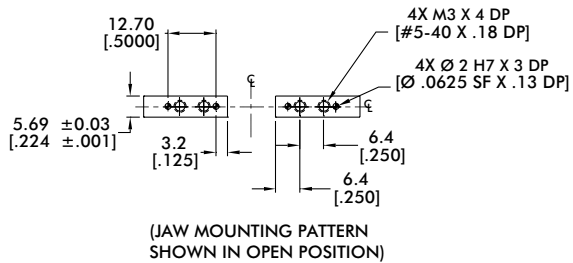
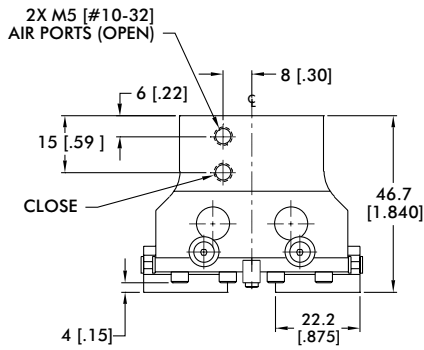
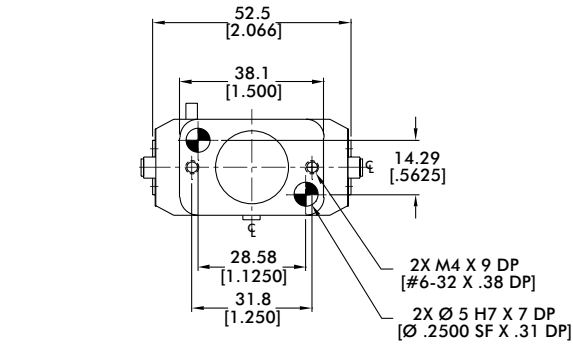

Sensor Accessories	RP-50P
Inductive Sensor Mounting Kit for (mounts 2 sensors)	OSMK-003
Seal Repair Kits	RP-50P
Buna-N Seal Repair Kit	SLKT-053
Viton® Seal Repair Kit	SLKT-053V

Loading Information

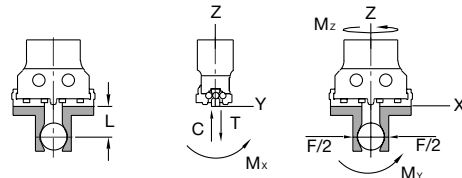
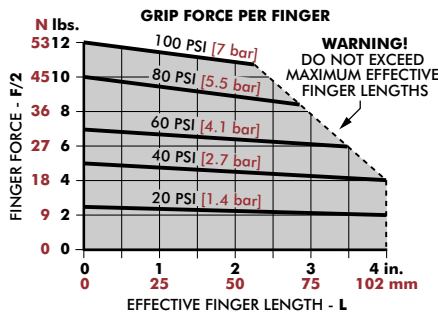

RP-50P	Static	Dynamic
Maximum Tensile T	222 N [50 lbs]	67 N [15 lbs]
Maximum Compressive C	222 N [50 lbs]	67 N [15 lbs]
Maximum Moment M_x	6 Nm [50 in-lbs]	1 Nm [12 in-lbs]
Maximum Moment M_y	7 Nm [60 in-lbs]	2 Nm [15 in-lbs]
Maximum Moment M_z	6 Nm [50 in-lbs]	1 Nm [12 in-lbs]

*Capacities are per set of jaws and are not simultaneous

RP-25P

2-Jaw Precision Parallel Grippers | Dimensions and Technical Specifications

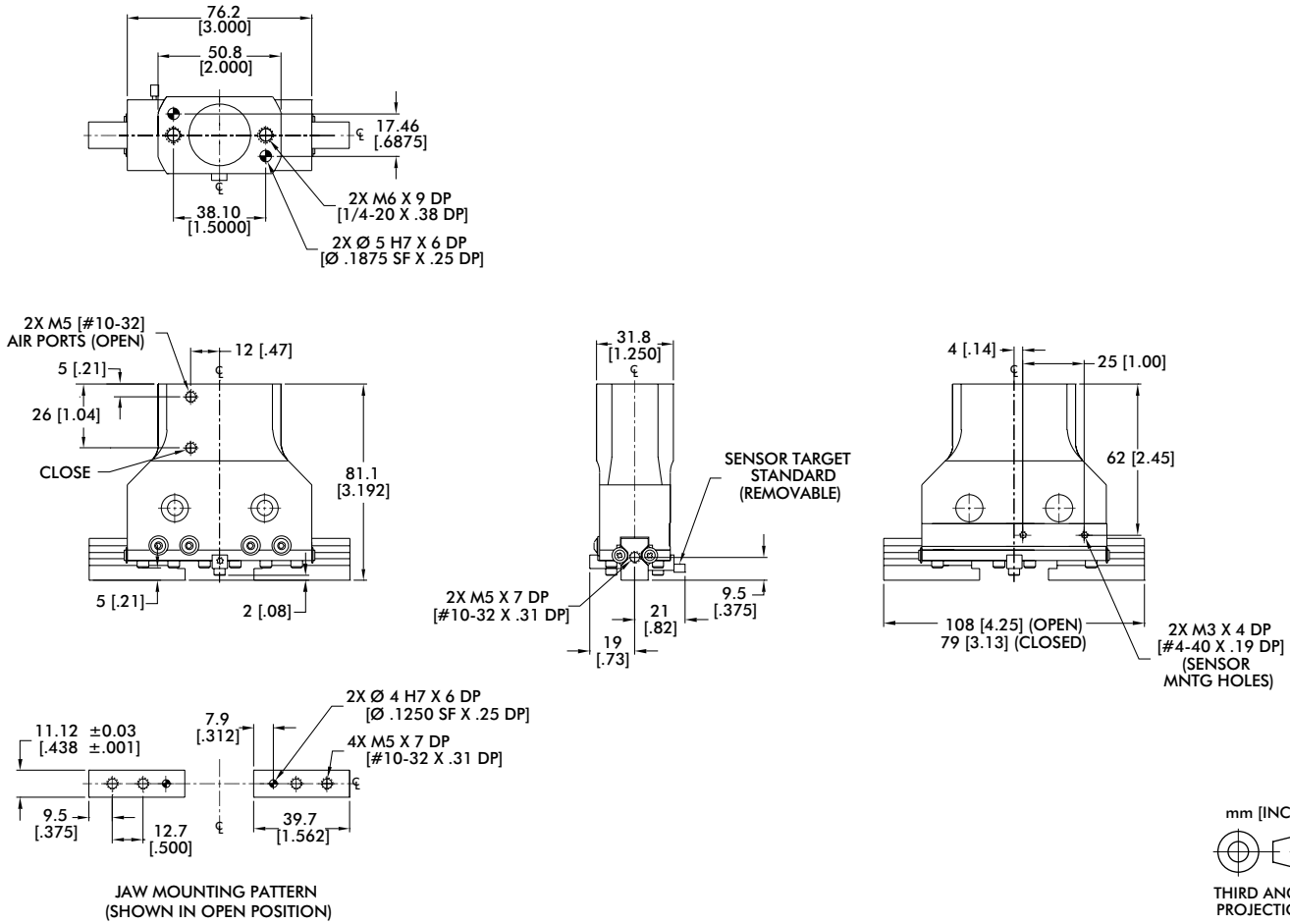

Sensor Accessories	RP-25P
Inductive Sensor Mounting Kit for (mounts 2 sensors)	OSMK-004

Seal Repair Kits	RP-25P
Buna-N Seal Repair Kit	SLKT-046
Viton® Seal Repair Kit	SLKT-046V

Loading Information

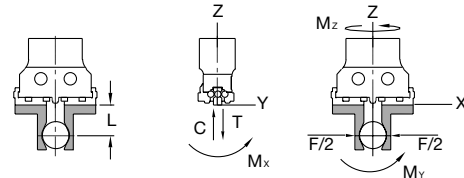
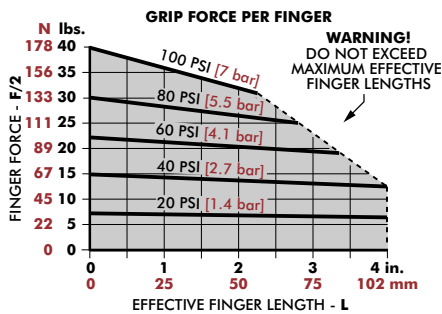

RP-25P	Static	Dynamic
Maximum Tensile T	445 N [100 lbs]	133 N [30 lbs]
Maximum Compressive C	445 N [100 lbs]	133 N [30 lbs]
Maximum Moment M_x	23 Nm [200 in-lbs]	6 Nm [50 in-lb]
Maximum Moment M_y	28 Nm [250 in-lbs]	7 Nm [60 in-lbs]
Maximum Moment M_z	23 Nm [200 in-lbs]	6 Nm [50 in-lbs]

^cCapacities are per set of jaws and are not simultaneous

2-Jaw Precision Parallel Grippers | Dimensions and Technical Specifications

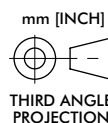
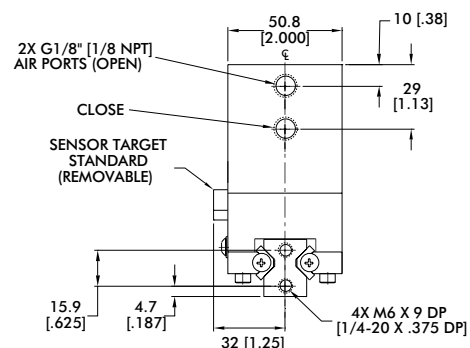
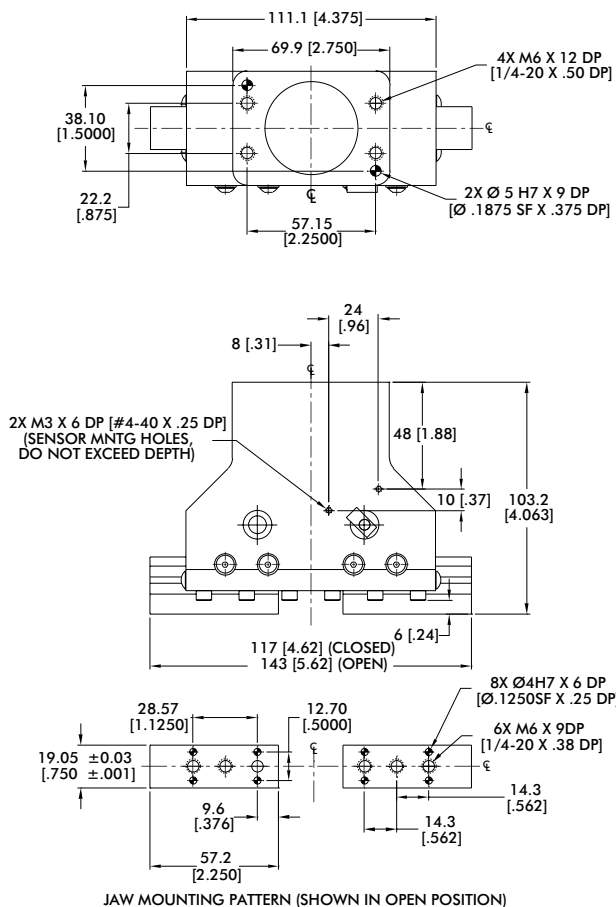

Sensor Accessories

Inductive Sensor Mounting Kit for (mounts 2 sensors) OSMK-023

Seal Repair Kits

Buna-N Seal Repair Kit SLKT-049

Viton® Seal Repair Kit SLKT-049V

Loading Information

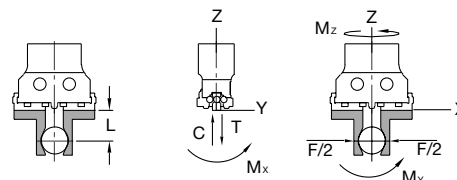
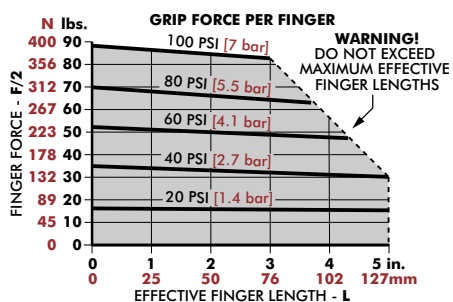

RP-35P	Static	Dynamic
Maximum Tensile T	890 N [200 lb]	334 N [75 lb]
Maximum Compressive C	890 N [200 lb]	334 N [75 lb]
Maximum Moment M_x	57 Nm [500 in-lb]	14 Nm [125 in-lb]
Maximum Moment M_y	68 Nm [600 in-lb]	17 Nm [150 in-lb]
Maximum Moment M_z	57 Nm [500 in-lb]	14 Nm [125 in-lb]

*Capacities are per set of jaws and are not simultaneous

RP-40P

2-Jaw Precision Parallel Grippers | Dimensions and Technical Specifications

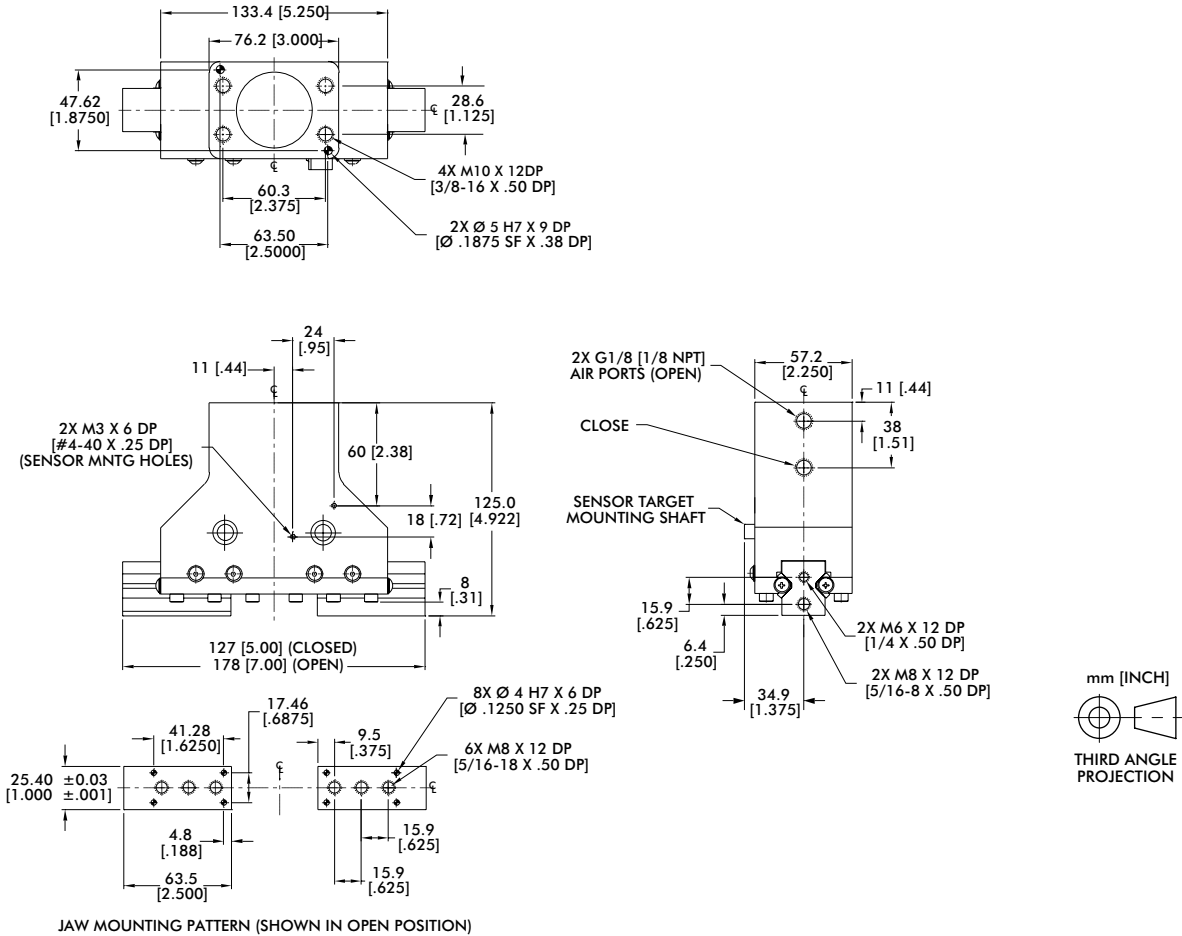

Sensor Accessories

Inductive Sensor Mounting Kit for (mounts 2 sensors) **RP-40P** OSMK-023

Seal Repair Kits

Buna-N Seal Repair Kit **RP-40P** SLKT-050
Viton® Seal Repair Kit SLKT-050V

Loading Information

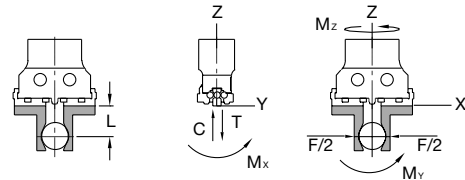
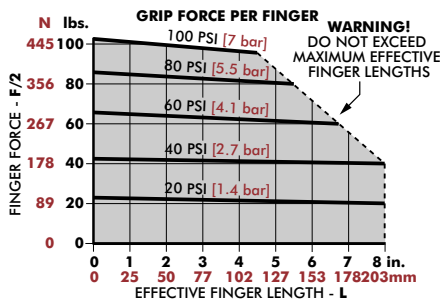

RP-40P	Static	Dynamic
Maximum Tensile T	1779 N [400 lb]	667 N [150 lb]
Maximum Compressive C	1779 N [400 lb]	667 N [150 lb]
Maximum Moment M_x	113 Nm [1000 in-lb]	28 Nm [250 in-lb]
Maximum Moment M_y	136 Nm [1200 in-lb]	34 Nm [300 in-lb]
Maximum Moment M_z	113 Nm [1000 in-lb]	28 Nm [250 in-lb]

*Capacities are per set of jaws and are not simultaneous

2-Jaw Precision Parallel Grippers | Dimensions and Technical Specifications

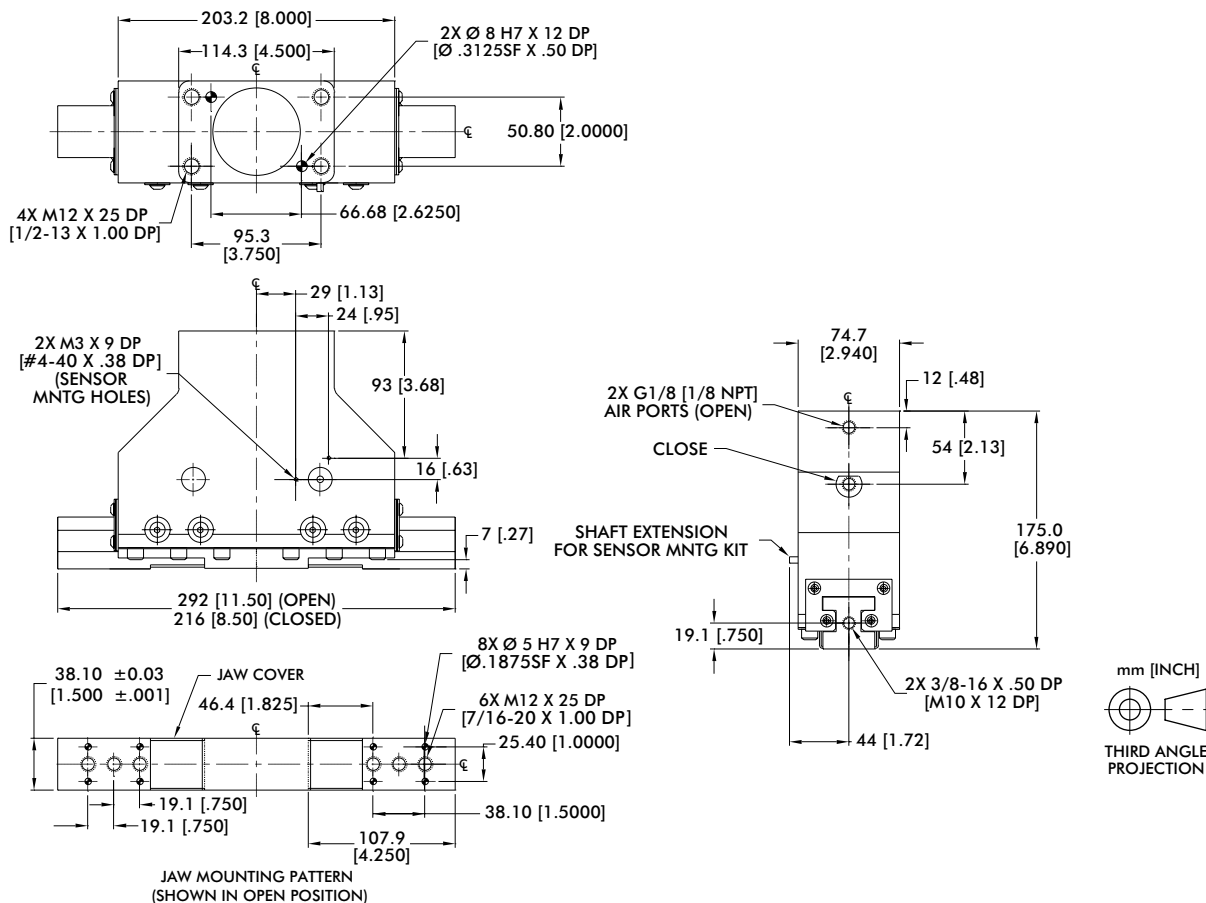

Sensor Accessories RP-43P

Inductive Sensor Mounting Kit for (mounts 2 sensors) OSMK-023

Seal Repair Kits RP-43P

Buna-N Seal Repair Kit SLKT-051

Viton® Seal Repair Kit SLKT-051V

Loading Information

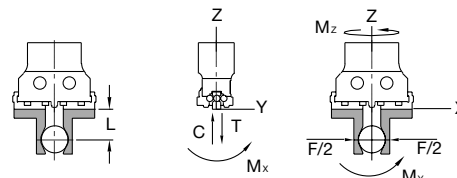
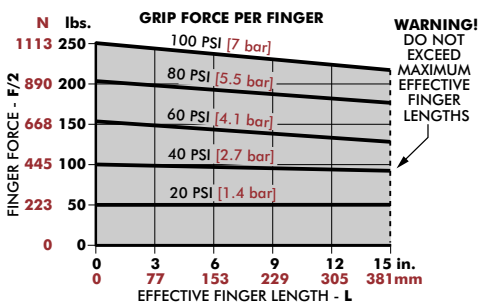

RP-43P	Static	Dynamic
Maximum Tensile T	4448 N [1000 lb]	1557 N [350 lb]
Maximum Compressive C	4448 N [1000 lb]	1557 N [350 lb]
Maximum Moment M_x	283 Nm [2500 in-lb]	57 Nm [500 in-lb]
Maximum Moment M_y	339 Nm [3000 in-lb]	68 Nm [600 in-lb]
Maximum Moment M_z	283 Nm [2500 in-lb]	57 Nm [500 in-lb]

*Capacities are per set of jaws and are not simultaneous

RPL/RPLC SERIES

2-Jaw Precision Parallel Grippers | Features and Benefits | How To Order

Features:

- Excellent part positioning and repeatability
- Zero side play using low friction Dual-V roller bearings
- Class 10 rated clean-room (RPLC) fits life Sciences applications
- Low friction for operation in low pressure applications, corrosion resistant design (RPLC)
- Optional non-synchronous jaw operation
- 30°C to +150°C [-20°F to +300°F] operating environment using Viton® seals option
- Purge port (RPLC) to prevent contaminants entering gripper
- Scavenge port (RPLC) prevents gripper grease from contaminating working environment

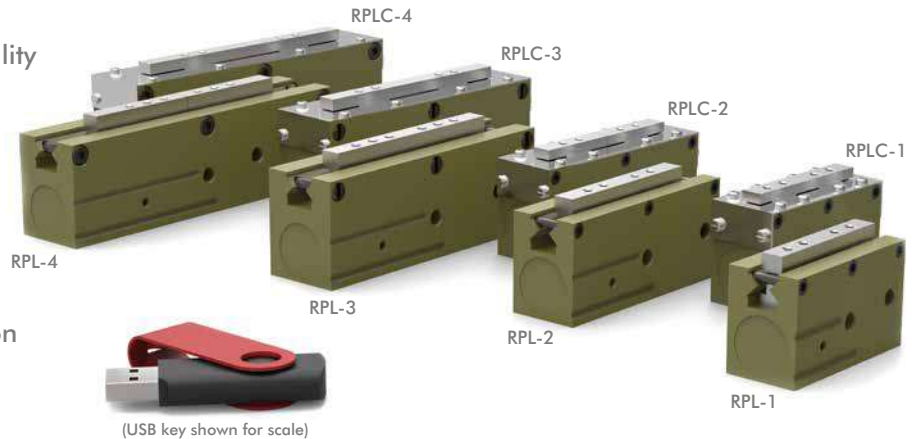

Applications:

- Clean room and harsh environments (RPLC)
- Delicate part handling with valve controls
- Long gripper finger requirements with precision
- High temperature applications using Viton® seals

How To Order

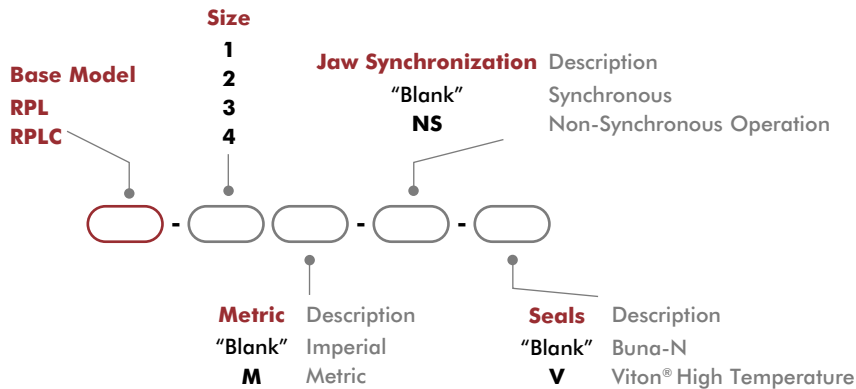

Accessories

Sensor Accessories	Model Numbers	Part Number	Qty/Unit
Sensor Mounting Kit for Imperial & Metric Units (mounts 2 sensors)	All Models	OSMK-008	1
NPN Magneto Resistive Sensor with Quick Disconnect*	All Models	OHSN-017	1-2
PNP Magneto Resistive Sensor with Quick Disconnect*	All Models	OHSP-017	1-2
Quick Disconnect 2 Meter Cable Length*	All Models	CABL-010	1-2
Quick Disconnect 5 Meter Cable Length*	All Models	CABL-013	1-2
Pneumatic Accessories	Model Numbers	Part Number	Qty/Unit
Fail Safe Valve (Imperial)	All Models	OFSV-001	1
Fail Safe Valve (Metric)	All Models	OFSV-004	1

*Sensor and cable sold separately.

RPL/RPLC SERIES

2-Jaw Precision Parallel Grippers | Technical Specifications

Specifications	Units	1	2	3	4
Total Rated Grip Force F @ 100 psi [7 bar]	N [lb]	116 [26]		160 [36]	
Total Stroke	mm [in]	6.4 [0.25]	12.7 [0.50]	19.1 [0.75]	25.4 [1.00]
Weight	kg [lbs]	0.07 [0.16]	0.09 [0.20]	0.15 [0.32]	0.17 [0.38]
Pressure Range	bar [psi]	0.3-7 [5-100]			
Ingress Protection Class (IP)		IP 33 (RPL) / IP64 (RPLC)			
Displacement	cm ³ [in ³]	0.6 [0.038]	1.2 [0.075]	2.4 [0.147]	3.2 [0.196]
Temperature Range (Buna-N seals)	°C [°F]	-35°~80° C [-30°~180° F]			
Temperature Range (Viton® seals)	°C [°F]	-30°~120° C [-20°~250° F]			
Actuation (open/close)	sec	0.10	0.13	0.14	0.19
Accuracy	mm [in]	±0.05 [±0.002]			
Repeatability	mm [in]	±0.03 [±0.001]			
Valve to Actuate		4-way, 2-position			

RPL/RPLC-1, RPL/RPLC-2

2-Jaw Precision Parallel Grippers | Dimensions and Technical Specifications

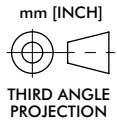
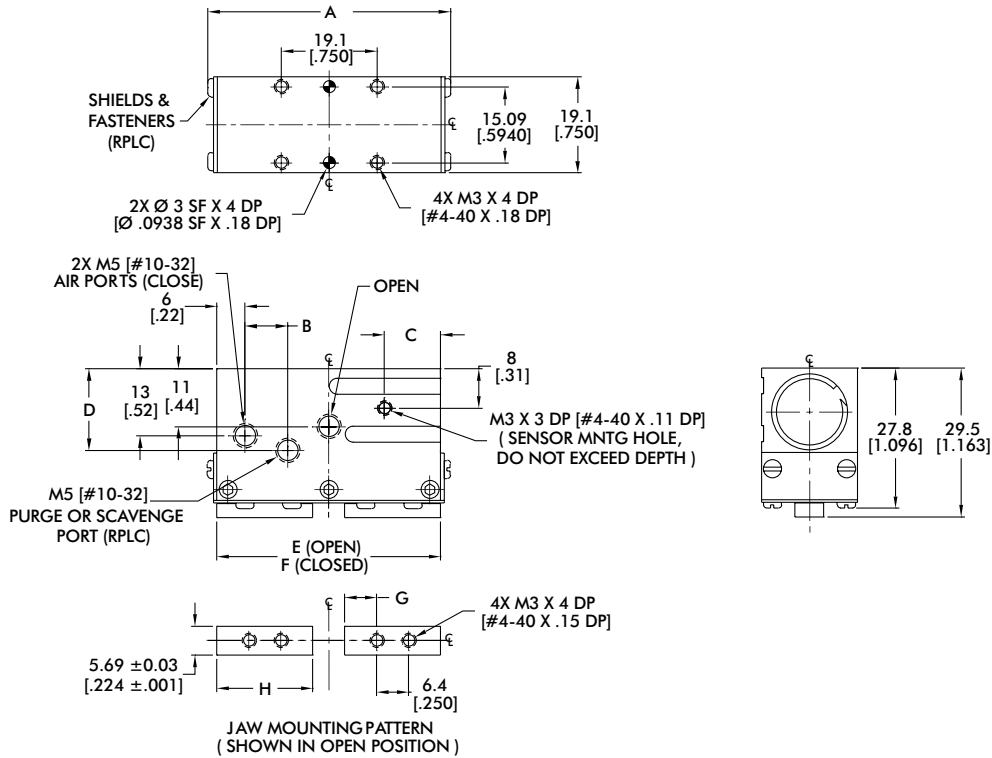

Model	A	B	C	D	E	F	G	H
RPL-1	44.5 [1.750]	--	11 [0.45]	--	44 [1.75]	38 [1.50]	6.4 [0.250]	19.1 [0.750]
RPL-2	59.5 [2.344]	--	16 [0.62]	--	57 [2.25]	44 [1.75]	6.4 [0.250]	22.2 [0.875]

Model	A	B	C	D	E	F	G	H
RPLC-1	48.3 [1.900]	8 [0.33]	11 [0.44]	17.3 [0.68]	44 [1.75]	38 [1.50]	6.4 [0.250]	19.1 [0.750]
RPLC-2	62.9 [2.476]	13 [0.50]	16 [0.62]	17.3 [0.68]	59 [2.33]	46 [1.83]	8.3 [0.328]	23.2 [0.913]

Dimensions in mm [in]

Seal Repair Kits	1, 2
Buna-N Seal Repair Kit	SLKT-010
Viton® Seal Repair Kit	SLKT-010V

Loading Information

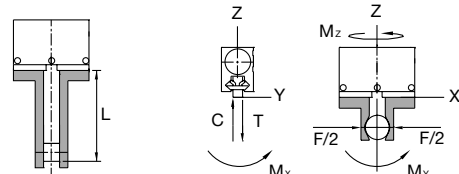
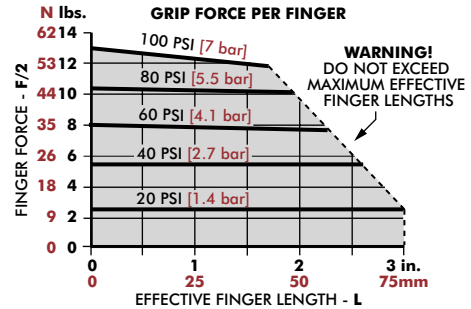
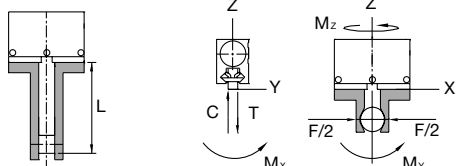
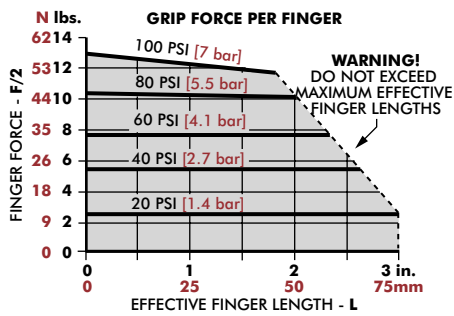

RPL-1	Static	Dynamic
Maximum Tensile T	222 N [50 lbs]	67 N [15 lbs]
Maximum Compressive C	222 N [50 lbs]	67 N [15 lbs]
Maximum Moment M_x	3.4 Nm [30 in-lbs]	1.1 Nm [10 in-lbs]
Maximum Moment M_y	4.5 Nm [40 in-lbs]	1.4 Nm [12 in-lbs]
Maximum Moment M_z	3.4 Nm [30 in-lbs]	1.1 Nm [10 in-lbs]

†Capacities are per set of jaws and are not simultaneous

RPL-2	Static	Dynamic
Maximum Tensile T	289 N [65 lbs]	89 N [20 lbs]
Maximum Compressive C	289 N [65 lbs]	89 N [20 lbs]
Maximum Moment M_x	5.1 Nm [45 in-lbs]	1.7 Nm [15 in-lbs]
Maximum Moment M_y	6.8 Nm [60 in-lbs]	2.3 Nm [20 in-lbs]
Maximum Moment M_z	5.1 Nm [45 in-lbs]	1.7 Nm [15 in-lbs]

†Capacities are per set of jaws and are not simultaneous

RPL/RPLC-3, RPL/RPLC-4

2-Jaw Precision Parallel Grippers | Dimensions and Technical Specifications

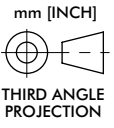
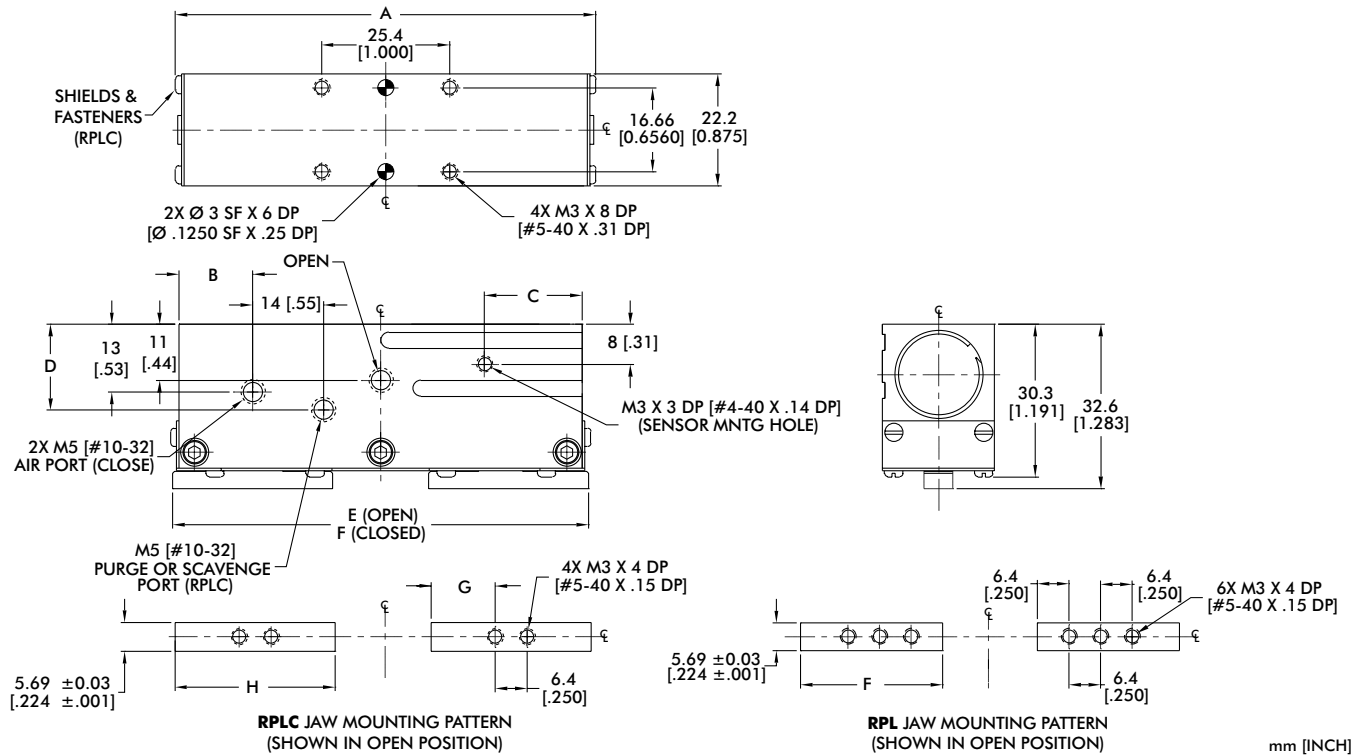

Model	A	B	C	D	E	F	G	H
RPL-3	80 [3.150]	15 [0.58]	19 [0.76]	--	76 [3.00]	57 [2.25]	--	28.6 [1.125]
RPL-4	98.4 [3.875]	30 [1.19]	25 [1.00]	--	92 [3.63]	66 [2.63]	--	33.3 [1.313]

Model	A	B	C	D	E	F	G	H
RPLC-3	83.4 [3.282]	15 [1.58]	19 [0.76]	18 [0.74]	83 [3.25]	63 [2.50]	12.7 [0.500]	31.8 [1.250]
RPLC-4	101.8 [4.007]	24 [0.94]	25 [1.00]	18 [0.74]	101 [4.00]	76 [3.00]	15.9 [0.625]	38.1 [1.50]

Dimensions in mm [in]

Seal Repair Kits	3, 4
Buna-N Seal Repair Kit	SLKT-012
Viton® Seal Repair Kit	SLKT-012V

Loading Information

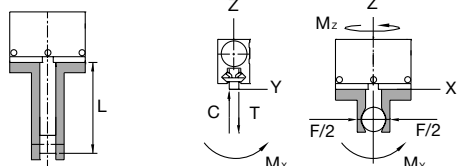
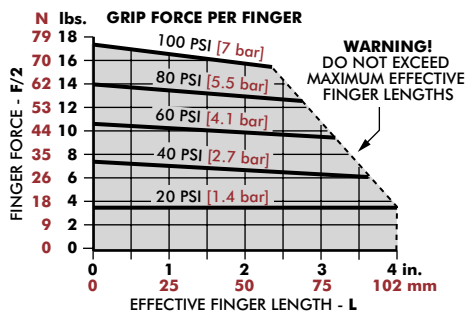

RPL-3	Static	Dynamic
Maximum Tensile T	400 N [90 lbs]	133 N [30 lbs]
Maximum Compressive C	400 N [90 lbs]	133 N [30 lbs]
Maximum Moment M_x	6.8 Nm [60 in-lbs]	2.3 Nm [20 in-lbs]
Maximum Moment M_y	9.0 Nm [80 in-lbs]	2.8 Nm [25 in-lbs]
Maximum Moment M_z	6.8 Nm [60 in-lbs]	2.3 Nm [20 in-lbs]

*Capacities are per set of jaws and are not simultaneous

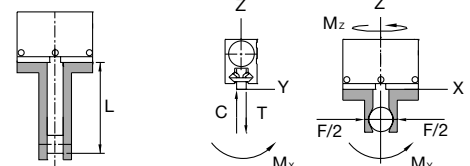
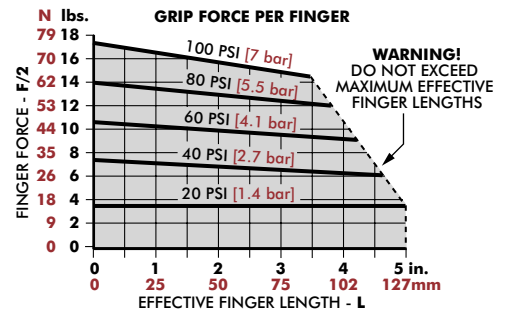

RPL-4	Static	Dynamic
Maximum Tensile T	534 N [120 lbs]	178 N [40 lbs]
Maximum Compressive C	534 N [120 lbs]	178 N [40 lbs]
Maximum Moment M_x	8.5 Nm [75 in-lbs]	2.8 Nm [25 in-lbs]
Maximum Moment M_y	11.3 Nm [100 in-lbs]	4.0 Nm [35 in-lbs]
Maximum Moment M_z	8.5 Nm [75 in-lbs]	2.8 Nm [25 in-lbs]

*Capacities are per set of jaws and are not simultaneous

PNEUMATIC INDUSTRIAL GRIPPERS

2-Jaw General Industrial Grippers | Product Overview

	Model	Stroke mm [in]	Grip Force N [lbs]	Operating Environment	Special Features	Page GR-GEN-#
CP		4-32 [0.16-1.26]	60-2749 [13-618]	IP54	Compact Design with High Grip Force.	3
DPDL		3.2-19.1 [0.13-0.75]	62-1779 [14-400]	IP66 Using Purge Port & Boot Option. Clean Room Class 100, ISO 5 Using Scavenge Port	Sealed Gripper. Dirty and Caustic Environments. Wide Range of Sizes. DIRECTCONNECT	11
DPDS		4.8-50.8 [0.188-2]	62-1779 [14-400]	IP54 Using Purge Port. Clean Room Class 10, ISO 4 Using Scavenge Port	Rugged General Purpose Applications. Wide Range of Sizes. DIRECTCONNECT	19
DPG		6.35-25.4 [0.25-1.0]	222-249 [50-56]	IP54. Clean Room Class 100, ISO 5	8 Position Sensing General Purpose Gripper. Multiple Mounting/Porting Options. DIRECTCONNECT	27
RDH		4-70 [0.16-2.73]	361-28002 [81-6300]	IP55 Using Purge Port. Clean Room Class 100, ISO 5 Using Scavenge Port	Highest Force vs. Size & Weight. Wide Range of Sizes. High Precision. Long Fingers. Rugged Applications	31
REP2		10-30 [0.39-1.181]	480-3268 [108-753]	IP55. Class 100, ISO 5 Using Scavenge Port	Spring Assist. Rugged and Harsh Environments. High Precision.	41
RP		4.0-50.8 [0.16-2]	156-3336 [35-750]	IP43	Small General Purpose. Rugged Applications. Wide Range of Sizes. Cost Effective	47, 51
RPM		3.2-6.3 [0.13-0.25]	36 [8]	IP33	Smallest Gripper, Low Friction, Small Parts Handling.	59
RPMC		3.2-6.3 [0.13-0.25]	36 [8]	IP64 Using Purge Port. Clean Room Class 10, ISO 4 Using Scavenge Port	Smallest Shielded Gripper for Clean or Harsh Environments. Small Delicate Parts Handling.	59
RPS		4-43 [0.16-1.7]	222-2669 [50-600]	IP43	Spring Assist, General Purpose Gripper. Rugged Applications. Wide Range of Sizes. Cost Effective	63

PNEUMATIC INDUSTRIAL GRIPPERS

2-Jaw General Industrial Grippers | DIRECTCONNECT™ Mounting Compatibility Chart

DIRECTCONNECT Modular Direct Mounting System without Adapter Plates

Products can be mounted in multiple positions. Refer to datasheet for complete info.

Slide to Gripper

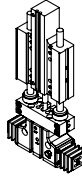

DLT Thruster Slide to DPDL Parallel Gripper

Slide to Gripper

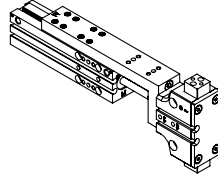

DLM Thruster Slide to DPDL Parallel Gripper

Slide to Gripper

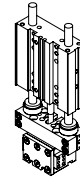

DLT Thruster Slide to DPDS Parallel Gripper

Slide to Gripper

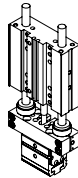

DLT Thruster Slide to DPDS Parallel Gripper

Slide to Gripper

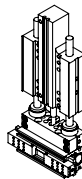

DLT Thruster Slide to DPG Parallel Gripper

Slide to Gripper

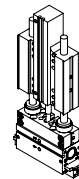

DLT Thruster Slide to DPG Parallel Gripper

DIRECTCONNECT

Mounting Compatibility Chart

DESTACO's DIRECTCONNECT™ technology, allows all components of the system—grippers and slides—to be mounted together directly. Look for matching icons on product datasheets for mounting compatibility.

Note: The numbers in the cell represent the metric screw size and basic mounting pattern.

S=Square, R=Rectangle. ie; 5S = M5 Screw with square mounting pattern.

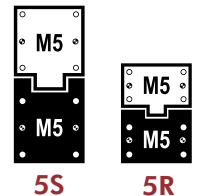

Catalog Models								
		DPDS-047, 056	DPDS-088, 125	DPDS-175, 250	DPDL-047, 056	DPDL-088, 125	DPDL-175, 250	DPG
Base Slides	DLB-06,08		3R			3R		
	DLB-10,12,16	5R		5R			5R	5R
	DLB-20,25				10R			
Thruster Slides	DLT-06,08		3R			3R		
	DLT-10,12,16	5R	3R	5R		3R	5R	5R
	DLT-20,25	5R		5R	10R		5R	5R
	DLM-07		3R			3R		
	DLM-9,12	5R	3R	5R		3R	5R	5R

CP SERIES

2-Jaw General Industrial Grippers | Features and Benefits | How To Order

Features:

- Compact cam lever design general purpose square gripper
- Two jaw styles available, parallel or extended finger jaw
- Spring assist option for part retention in case of air pressure loss
- Standard and extended stroke option available
- Shielded design for harsh environments
- Magneto-resistive and Inductive sensing

Applications:

- OEM pick and place machines
- Packaging applications
- General purpose gripping

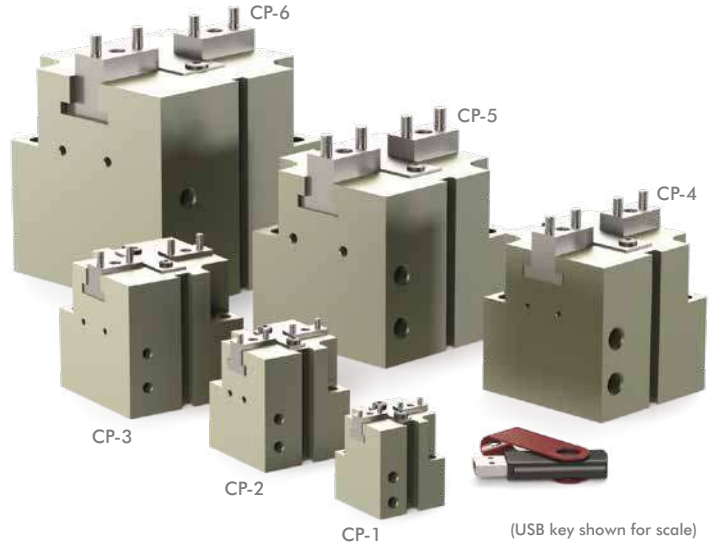

How To Order

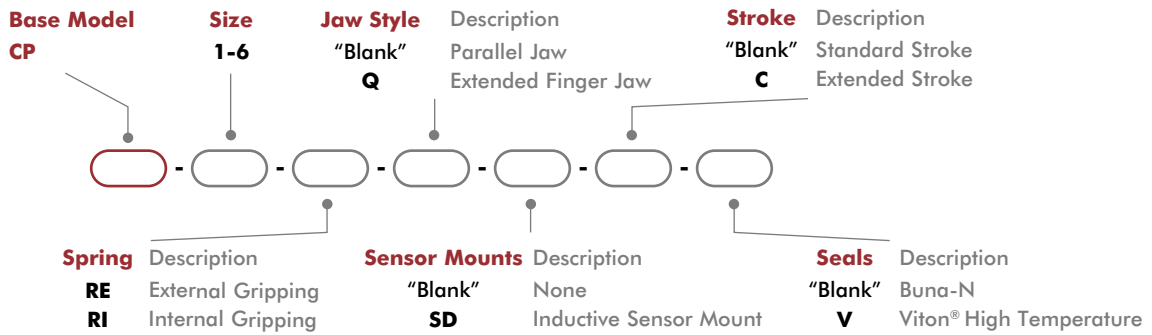

Accessories

Sensor Accessories	Model Numbers	Part Number	Qty/Unit
PNP Sensor with 0.3m Output Cable with 90° with M8 connector*	All Models	D1	1-2
NPN Sensor with 0.3m Output Cable with 90° with M8 connector*	CP-2, -3, -4, -5, -6	D10	1-2
PNP Sensor with 0.3m Output Cable with M8 connector*	All Models	D4	1-2
NPN Sensor with 0.3m Output Cable with M8 connector*	CP-2, -3, -4, -5, -6	D7	1-2
Inductive Sensor Mounting Kit (mounts 2 sensors) (SD)	See Datasheet		1
Inductive PNP Sensor with M8 Connector*	CP-2, -3, -4	OISP-011	1-2
Inductive NPN Sensor with M8 Connector*	CP-2, -3, -4	OISN-011	1-2
Inductive PNP Sensor with M12 Connector*	CP-5, -6	OISP-017	1-2
Inductive NPN Sensor with M12 Connector*	CP-5, -6	OISN-017	1-2
M8 Quick Disconnect 2 Meter Cable Length*	All Models	CABL-010	1-2
M12 Quick Disconnect 2 Meter Cable Length*	All Models	CABL-014	1-2

* Sensor and cable sold separately.

2-Jaw General Industrial Grippers | Technical Specifications

Specifications	Units	1	1-C	2	2-C	3	3-C
Total Rated Grip Force F @ 100 psi [7 bar] w/o Spring Assist	N [lbs]	89 [20]	60 [13]	238 [53]	161 [36]	677 [152]	407 [91]
Total Rated Grip Force F @ 100 psi [7 bar] with Spring Assist	N [lbs]	15 [3]	10 [2]	43 [10]	29 [7]	161 [36]	97 [22]
Total Stroke	mm [in]	4 [0.16]	6 [0.24]	6 [0.24]	9 [0.35]	10 [0.39]	16 [0.63]
Weight	kg [lbs]	0.09 [0.20]	0.09 [0.20]	0.21 [0.46]	0.20 [0.44]	0.45 [0.99]	0.47 [1.04]
Pressure Range w/o Spring	bar [psi]	2-10 [29-145]					
Pressure Range with Spring	bar [psi]	2.5-10 [36-145]					
Ingress Protection Class (IP)		IP54					
Displacement	cm ³ [in ³]	0.7 [0.04]		2.7 [0.16]		11.7 [0.71]	
Temperature Range	°C [°F]	-35°~80° [-30°~180°]					
Actuation (open/close)	sec	0.06				0.07	
Repeatability	mm [in]	±0.025 [±0.001]					
Valve to Actuate Single Acting		3-way, 2-position					
Valve to Actuate Double Acting		4-way, 2-position					

Specifications	Units	4	4-C	5	5-C	6	6-C
Total Rated Grip Force F @ 100 psi [7 bar] w/o Spring Assist	N [lbs]	1016 [228]	665 [149]	1591 [358]	1081 [243]	2749 [618]	2092 [470]
Total Rated Grip Force F @ 100 psi [7 bar] with Spring Assist	N [lbs]	222 [50]	145 [33]	322 [72]	219 [49]	711 [160]	541 [122]
Total Stroke	mm [in]	13 [0.51]	20 [0.79]	18 [0.71]	27 [1.06]	24 [0.94]	32 [1.26]
Weight	kg [lbs]	0.73 [1.61]	0.75 [1.65]	1.25 [2.76]	1.27 [2.80]	2.5 [5.51]	2.56 [5.64]
Pressure Range w/o Spring	bar [psi]	2-10 [29-145]					
Pressure Range with Spring	bar [psi]	2.5-10 [36-145]					
Ingress Protection Class (IP)		IP54					
Displacement	cm ³ [in ³]	24.2 [1.48]		53.5 [3.26]		114.8 [7.01]	
Temperature Range	°C [°F]	-35°~80° [-30°~180°]					
Actuation (open/close)	sec	0.07		0.09		0.12	
Repeatability	mm [in]	±0.025 [±0.001]					
Valve to Actuate Single Acting		3-way, 2-position					
Valve to Actuate Double Acting		4-way, 2-position					

CP-1, CP-1-C

2-Jaw General Industrial Grippers | Dimensions and Technical Specifications

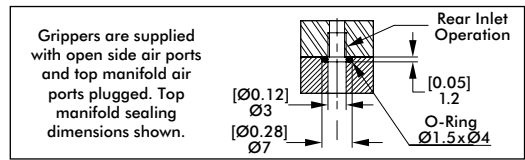
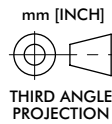
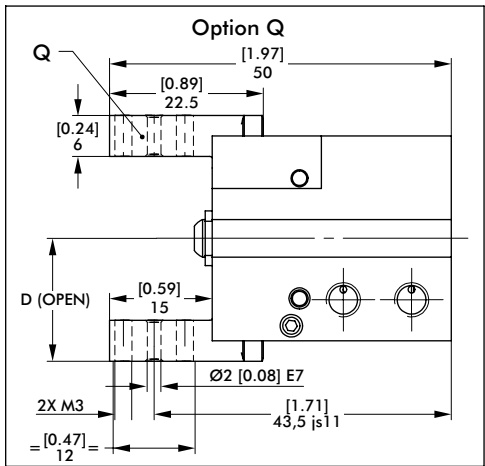
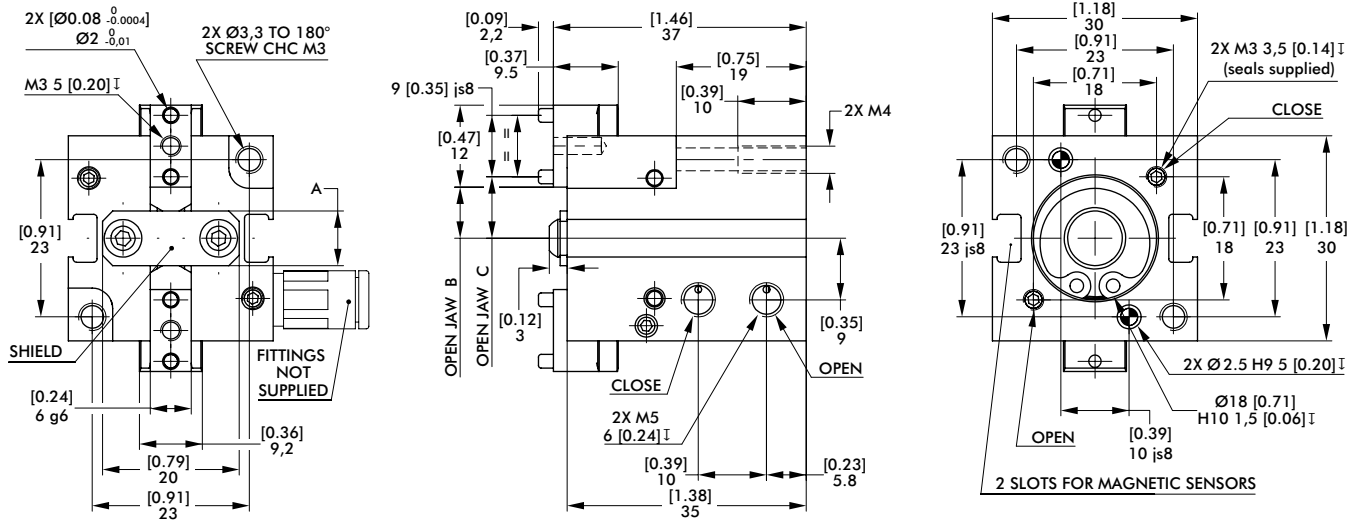

Seal Repair Kits	Buna-N	Viton®
Seal Repair Kit	SCP1	SCP1V
Repair Kit (screws, springs, seals)	KSCP1	KSCP1V

Model	A	B	C	D
CP-1	6 [0.24]	5.3 [0.21]	6.8 [0.27]	15.8 [0.62]
CP-1-C	8 [0.31]	7.5 [0.30]	9 [0.35]	18 [0.71]

Dimensions in mm [in]

Loading Information

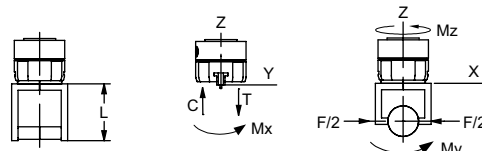
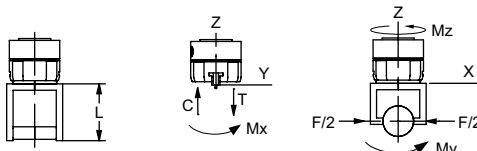
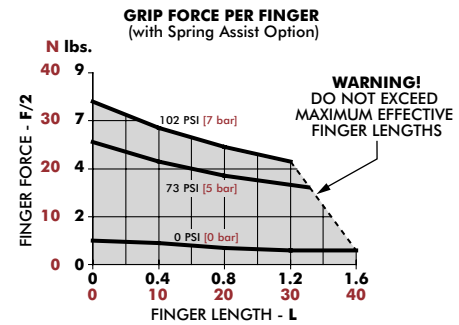
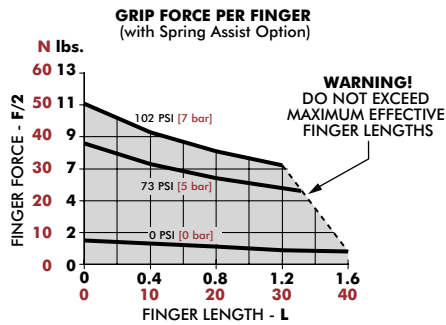

CP-1	Static	Dynamic
Maximum Tensile T	110 N [25 lbs]	10 N [2 lbs]
Maximum Compressive C	190 N [43 lbs]	10 N [2 lbs]
Maximum Moment M_x	1 Nm [9 in-lbs]	0.2 Nm [2 in-lbs]
Maximum Moment M_y	2 Nm [18 in-lbs]	0.4 Nm [4 in-lbs]
Maximum Moment M_z	2 Nm [18 in-lbs]	0.4 Nm [4 in-lbs]

*Capacities are per set of jaws and are not simultaneous

CP-1-C	Static	Dynamic
Maximum Tensile T	110 N [25 lbs]	8 N [2 lbs]
Maximum Compressive C	190 N [43 lbs]	8 N [2 lbs]
Maximum Moment M_x	1 Nm [9 in-lbs]	0.2 Nm [2 in-lbs]
Maximum Moment M_y	2 Nm [18 in-lbs]	0.3 Nm [3 in-lbs]
Maximum Moment M_z	2 Nm [18 in-lbs]	0.3 Nm [3 in-lbs]

*Capacities are per set of jaws and are not simultaneous

2-Jaw General Industrial Grippers | Dimensions and Technical Specifications

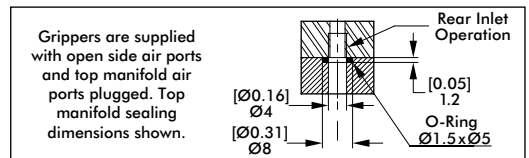
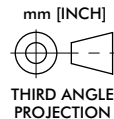
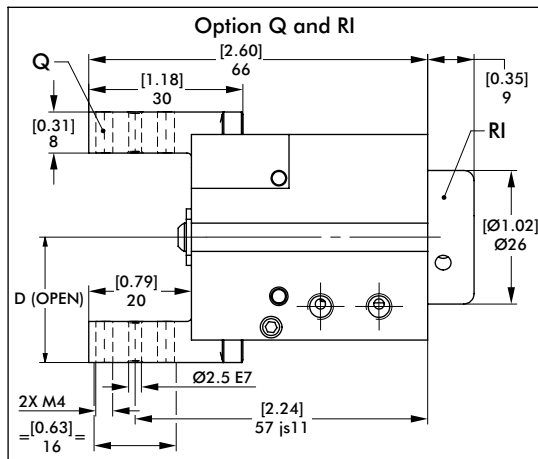
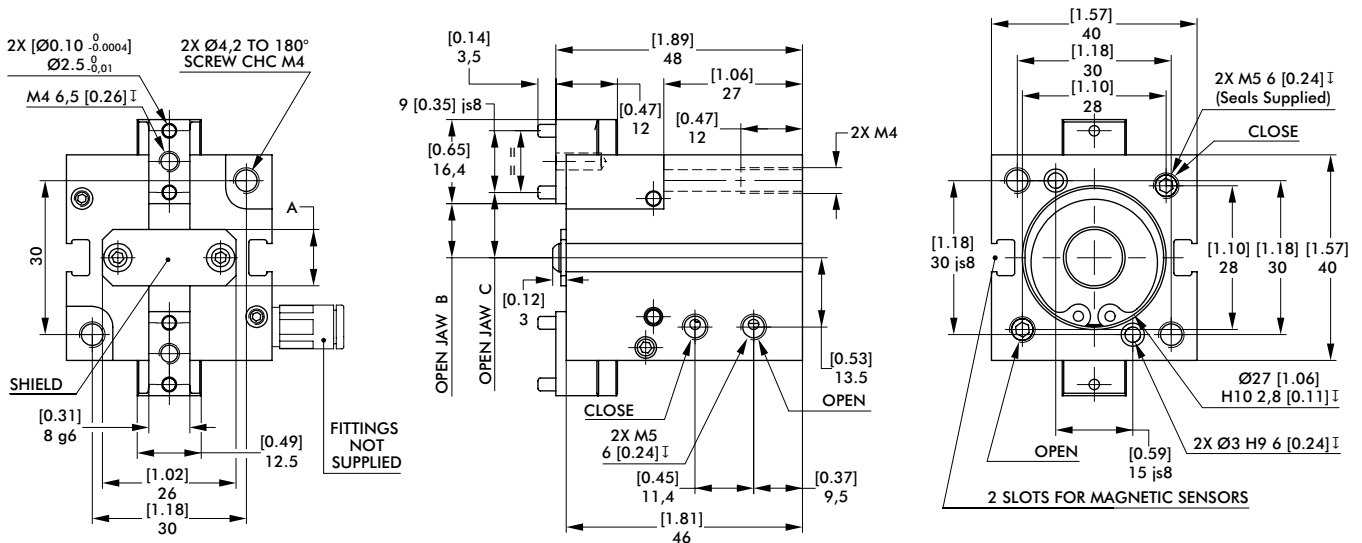

Sensor Accessories		CP-2
Inductive Sensor Mounting Kit (mounts 2 sensors) (SD)		SDCP2

Seal Repair Kits	Buna-N	Viton®
Seal Repair Kit	SCP2	SCP2V
Repair Kit (screws, springs, seals)	KSCP2	KSCP2V

Model	A	B	C	D
CP-2	7,5 [0.30]	7,1 [0.28]	9,3 [0.37]	21 [0.83]
CP-2-C	11 [0.43]	10,5 [0.41]	12,7 [0.50]	24,4 [0.96]

Dimensions in mm [in]

Loading Information

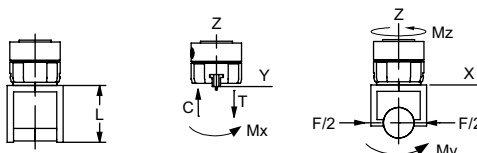
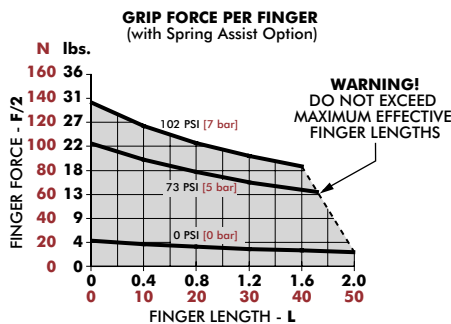

	Static	Dynamic
Maximum Tensile T	260 N [58 lbs]	26 N [6 lbs]
Maximum Compressive C	375 N [84 lbs]	26 N [6 lbs]
Maximum Moment M_x	5 Nm [44 in-lbs]	0.9 Nm [8 in-lbs]
Maximum Moment M_y	8 Nm [71 in-lbs]	1.5 Nm [13 in-lbs]
Maximum Moment M_z	8 Nm [71 in-lbs]	1.5 Nm [13 in-lbs]

*Capacities are per set of jaws and are not simultaneous

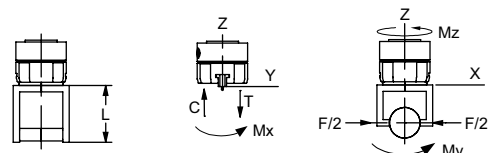
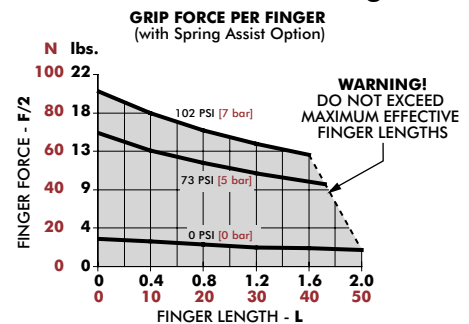

	Static	Dynamic
Maximum Tensile T	260 N [58 lbs]	22 N [5 lbs]
Maximum Compressive C	375 N [84 lbs]	22 N [5 lbs]
Maximum Moment M_x	4 Nm [35 in-lbs]	0.7 Nm [6 in-lbs]
Maximum Moment M_y	8 Nm [71 in-lbs]	1.2 Nm [11 in-lbs]
Maximum Moment M_z	8 Nm [71 in-lbs]	1.2 Nm [11 in-lbs]

*Capacities are per set of jaws and are not simultaneous

CP-3, CP-3-C

2-Jaw General Industrial Grippers | Dimensions and Technical Specifications

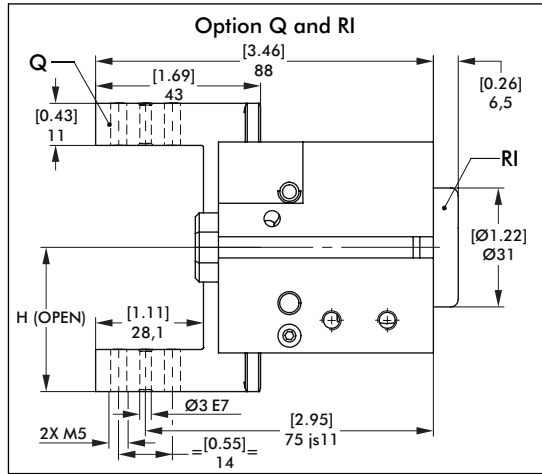
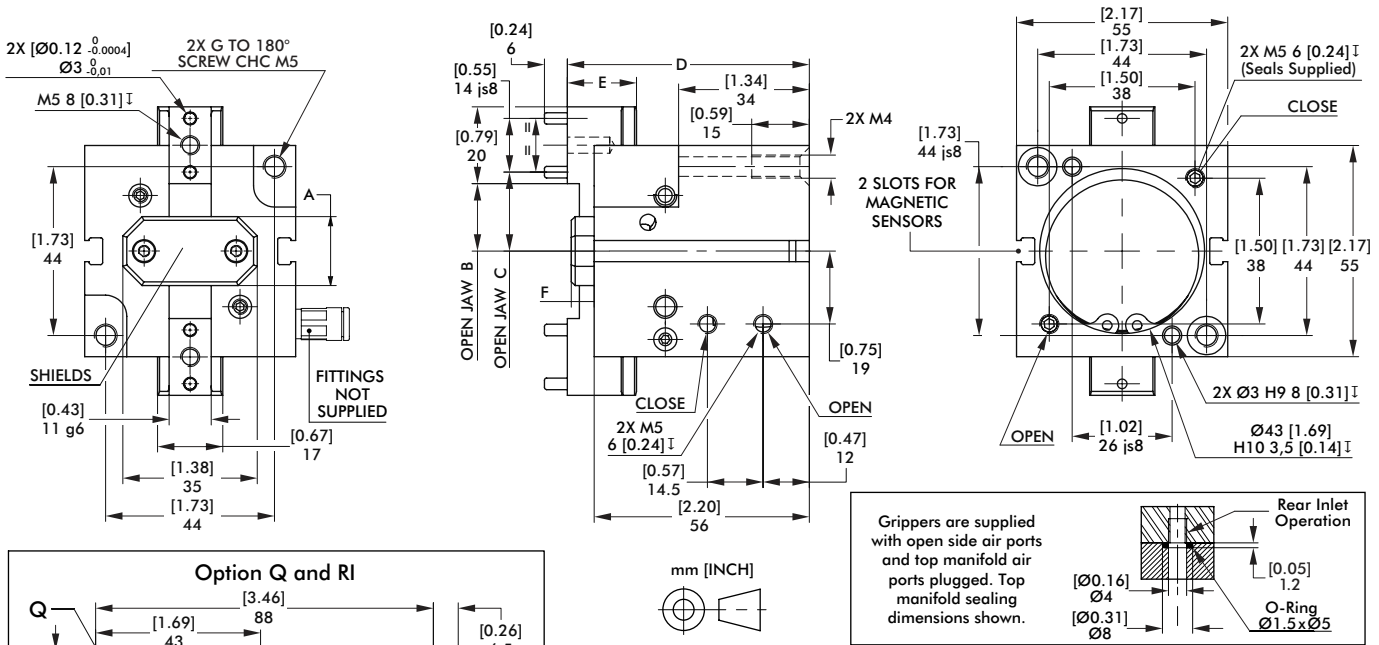

Sensor Accessories	CP-3
Inductive Sensor Mounting Kit (mounts 2 sensors) (SD)	SDCP3

Seal Repair Kits	Buna-N	Viton®
Seal Repair Kit	SCP3	SCP3V
Repair Kit (screws, springs, seals)	KSCP3	KSCP3V

Model	A	B	C	D	E
CP-3	12 [0.47]	12 [0.47]	15 [0.59]	58 [2.28]	13 [0.51]
CP-3-C	18 [0.71]	17.6 [0.69]	20.6 [0.81]	63 [2.48]	18 [0.71]

Model	F	G	H	J
CP-3	3 [0.12]	3.3 [0.13]	84 [3.31]	32 [1.26]
CP-3-C	6 [0.24]	5.1 [0.20]	88 [3.46]	37.6 [1.48]

Dimensions in mm [in]

Loading Information

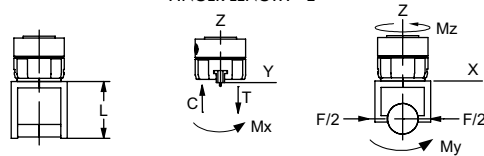
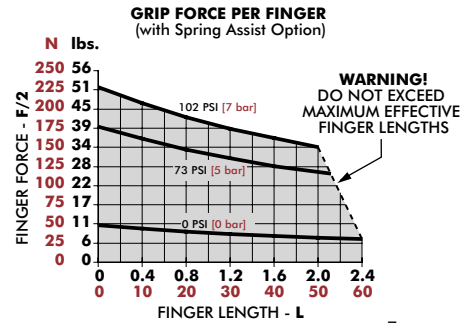
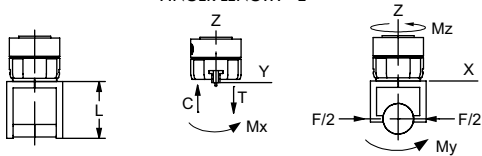
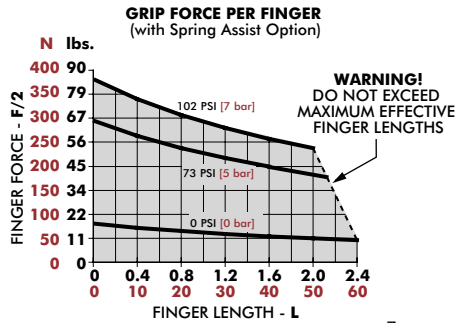

CP-3	Static	Dynamic
Maximum Tensile T	520 N [117 lbs]	72 N [16 lbs]
Maximum Compressive C	690 N [155 lbs]	72 N [16 lbs]
Maximum Moment M_x	11 Nm [97 in-lbs]	3.5 Nm [31 in-lbs]
Maximum Moment M_y	18 Nm [159 in-lbs]	6 Nm [53 in-lbs]
Maximum Moment M_z	17 Nm [150 in-lbs]	6 Nm [53 in-lbs]

[†]Capacities are per set of jaws and are not simultaneous

CP-3-C	Static	Dynamic
Maximum Tensile T	500 N [112 lbs]	55 N [12 lbs]
Maximum Compressive C	675 N [152 lbs]	55 N [12 lbs]
Maximum Moment M_x	9 Nm [80 in-lbs]	2.5 Nm [22 in-lbs]
Maximum Moment M_y	16 Nm [142 in-lbs]	4 Nm [35 in-lbs]
Maximum Moment M_z	17 Nm [150 in-lbs]	4 Nm [35 in-lbs]

[†]Capacities are per set of jaws and are not simultaneous

2-Jaw General Industrial Grippers | Dimensions and Technical Specifications

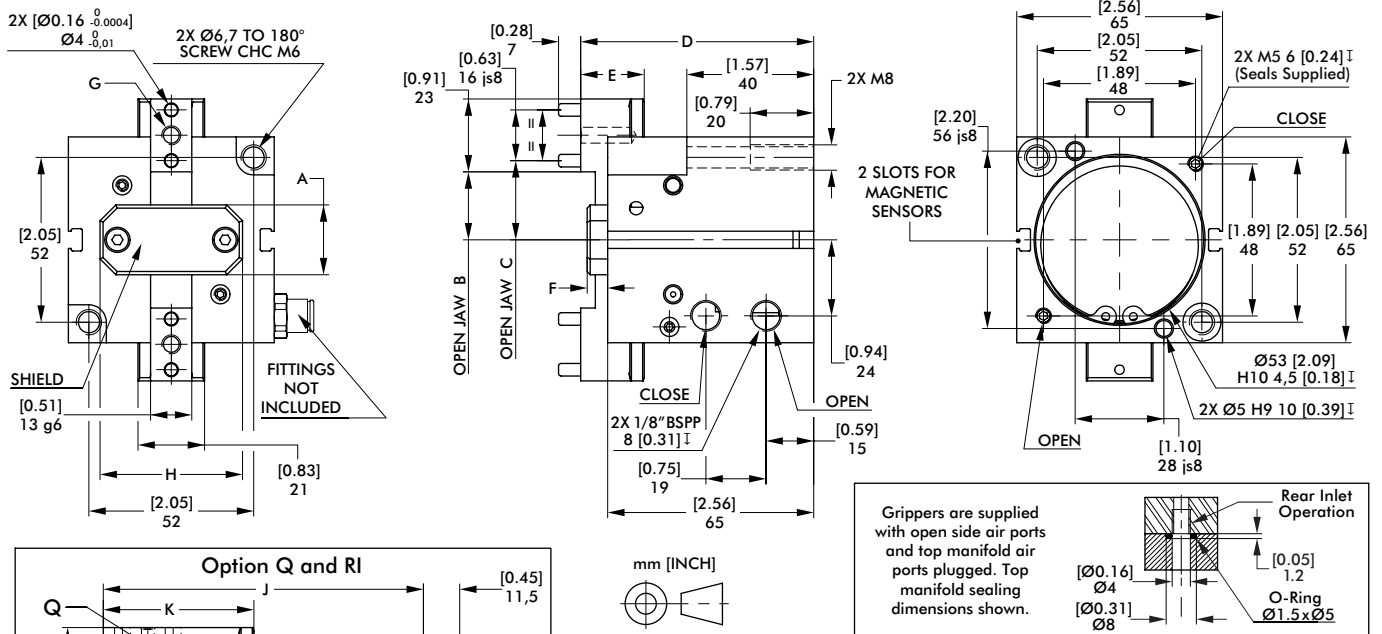

Grippers are supplied with open side air ports and top manifold air ports plugged. Top manifold sealing dimensions shown.

Rear Inlet Operation

Sensor Accessories

Inductive Sensor Mounting Kit (mounts 2 sensors) (SD) **CP-4**
SDCP4

Seal Repair Kits

Seal Repair Kit **Buna-N** SCP4 **Viton®** SCP4V

Repair Kit (screws, springs, seals) KSCP4 KSCP4V

Model	A	B	C	D	E	F
CP-4	16 [0.63]	16 [0.63]	19.5 [0.77]	73 [2.87]	19.5 [0.77]	3 [0.12]
CP-4-C	22 [0.87]	21.5 [0.85]	25 [0.98]	73.5 [2.89]	20 [0.79]	6.5 [0.26]

Model	G	H	J	K	L	M
CP-4	M5 8 [0.31]	46 [1.81]	97 [3.82]	43.5 [1.71]	83 [3.27]	39 [1.54]
CP-4-C	M6 12 [0.47]	45 [1.77]	101 [3.98]	47.5 [1.87]	87 [3.43]	44.5 [1.75]

Dimensions in mm [in]

Loading Information

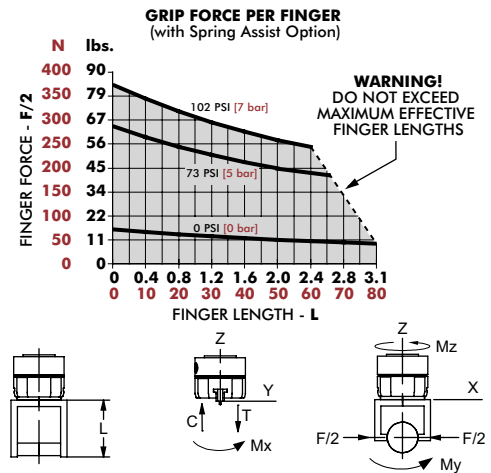
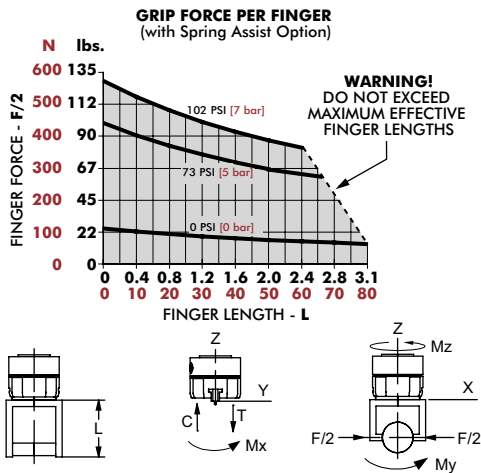

	Static	Dynamic
Maximum Tensile T	740 N [166 lbs]	109 N [24 lbs]
Maximum Compressive C	830 N [187 lbs]	109 N [24 lbs]
Maximum Moment M_x	23 Nm [204 in-lbs]	6.5 Nm [58 in-lbs]
Maximum Moment M_y	35 Nm [310 in-lbs]	10 Nm [89 in-lbs]
Maximum Moment M_z	25 Nm [221 in-lbs]	8 Nm [71 in-lbs]

Capacities are per set of jaws and are not simultaneous

	Static	Dynamic
Maximum Tensile T	710 N [160 lbs]	89 N [20 lbs]
Maximum Compressive C	800 N [180 lbs]	89 N [20 lbs]
Maximum Moment M_x	18 Nm [159 in-lbs]	4.7 Nm [42 in-lbs]
Maximum Moment M_y	30 Nm [266 in-lbs]	7.6 Nm [67 in-lbs]
Maximum Moment M_z	25 Nm [221 in-lbs]	7.6 Nm [67 in-lbs]

Capacities are per set of jaws and are not simultaneous

CP-5, CP-5-C

2-Jaw General Industrial Grippers | Dimensions and Technical Specifications

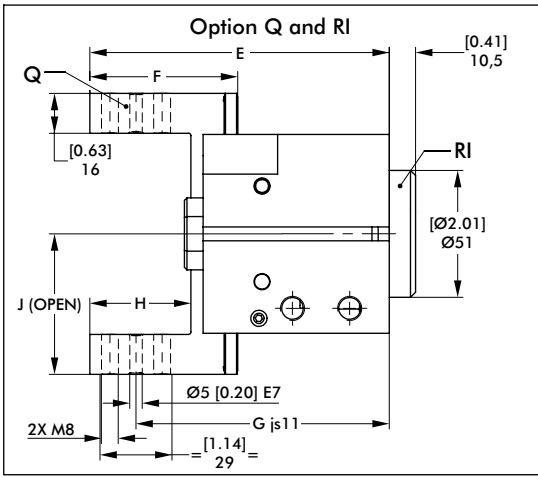
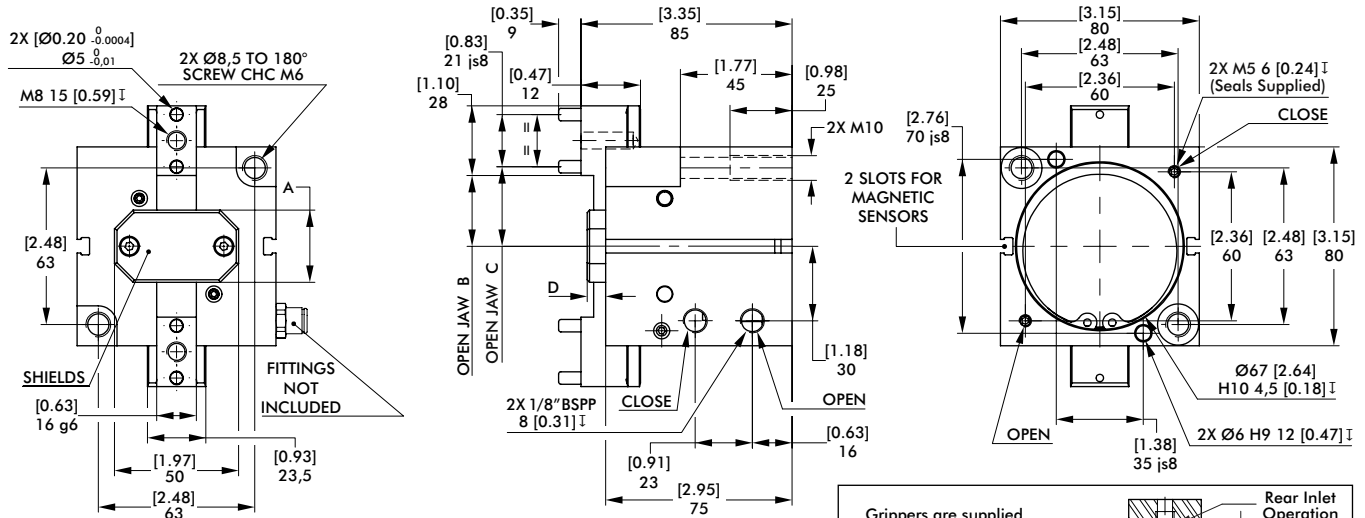

Sensor Accessories	CP-5
Inductive Sensor Mounting Kit (mounts 2 sensors) (SD)	SDCP5

Seal Repair Kits	Buna-N	Viton®
Seal Repair Kit	SCP5	SCP5V
Repair Kit (screws, springs, seals)	KSCP5	KSCP5V

Model	A	B	C	D	E
CP-5	20 [0.79]	19.5 [0.77]	23 [0.91]	3 [0.12]	115.5 [4.55]
CP-5-C	29 [1.14]	28.5 [1.12]	32 [1.26]	7.5 [0.30]	120.5 [4.74]

Model	F	G	H	J
CP-5	54.5 [2.15]	97 [3.82]	40.5 [1.59]	47.5 [1.87]
CP-5-C	59.5 [2.34]	102 [4.02]	40.6 [1.60]	56.5 [2.22]

Dimensions in mm [in]

Loading Information

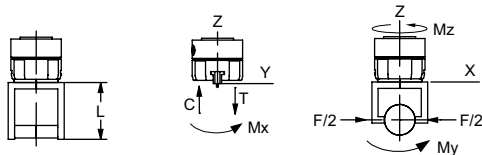
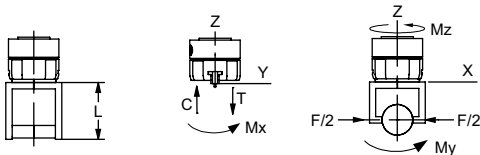
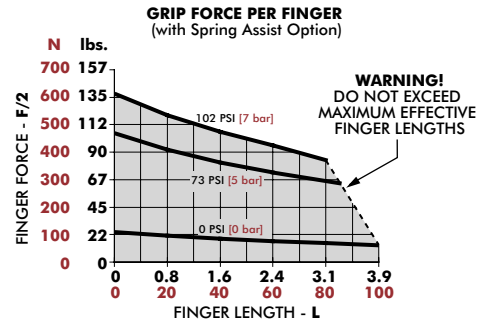
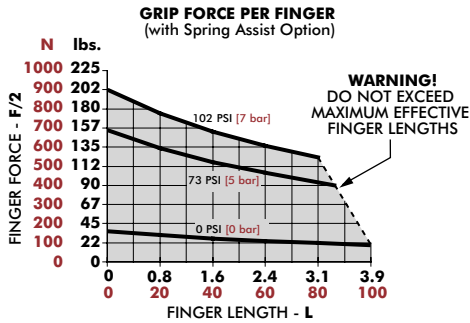

CP-5	Static	Dynamic
Maximum Tensile T	830 N [187 lbs]	169 N [38 lbs]
Maximum Compressive C	940 N [211 lbs]	169 N [38 lbs]
Maximum Moment M_x	27 Nm [6 in-lbs]	9 Nm [80 in-lbs]
Maximum Moment M_y	44 Nm [10 in-lbs]	14 Nm [124 in-lbs]
Maximum Moment M_z	30 Nm [7 in-lbs]	10 Nm [89 in-lbs]

*Capacities are per set of jaws and are not simultaneous

CP-5-C	Static	Dynamic
Maximum Tensile T	820 N [184 lbs]	144 N [32 lbs]
Maximum Compressive C	930 N [209 lbs]	144 N [32 lbs]
Maximum Moment M_x	22 Nm [195 in-lbs]	7 Nm [62 in-lbs]
Maximum Moment M_y	40 Nm [354 in-lbs]	13 Nm [115 in-lbs]
Maximum Moment M_z	30 Nm [266 in-lbs]	10 Nm [89 in-lbs]

*Capacities are per set of jaws and are not simultaneous

2-Jaw General Industrial Grippers | Dimensions and Technical Specifications

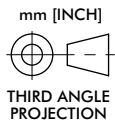
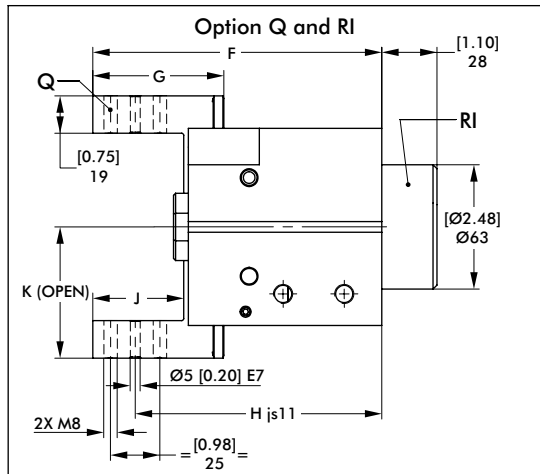
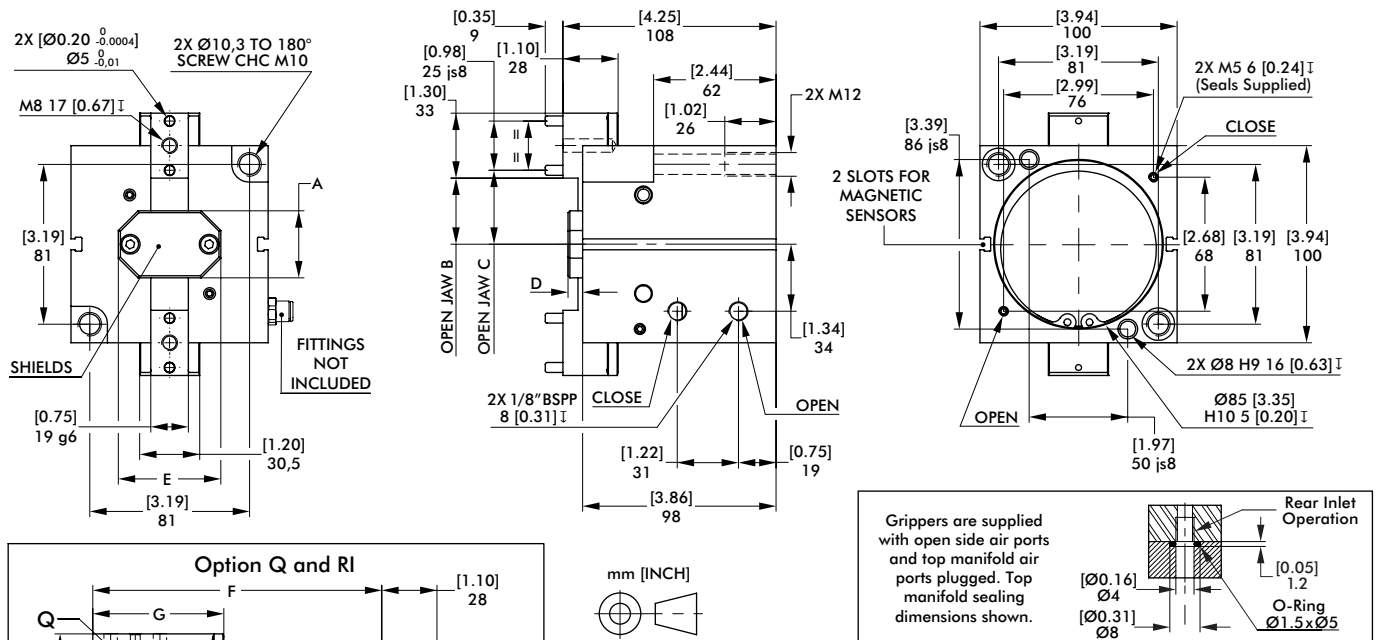

Sensor Accessories		CP-6
Inductive Sensor Mounting Kit (mounts 2 sensors) (SD)		SDCP6

Seal Repair Kits		Buna-N	Viton®
Seal Repair Kit		SCP6	SCP6V
Repair Kit (screws, springs, seals)		KSCP6	KSCP6V

Model	A	B	C	D	E
CP-6	26 [1.02]	25,5 [1.00]	29,5 [1.16]	3 [0.12]	50 [1.97]
CP-6-C	34 [1.34]	33,5 [1.32]	37,5 [1.48]	7,5 [0.30]	52 [2.05]

Model	F	G	H	J	K
CP-6	144 [5.67]	64 [2.52]	122,5 [4.82]	46 [1.81]	58,5 [2.30]
CP-6-C	146,5 [5.77]	66,5 [2.62]	125 [4.92]	46,1 [1.81]	66,5 [2.62]

Dimensions in mm [in]

Loading Information

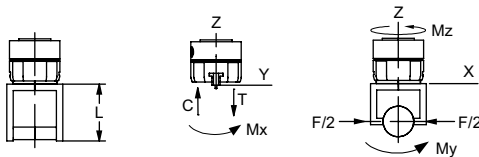
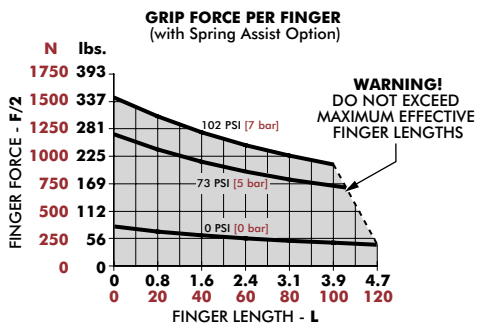

CP-6	Static	Dynamic
Maximum Tensile T	1375 N [309 lbs]	209 N [47 lbs]
Maximum Compressive C	1500 N [337 lbs]	209 N [47 lbs]
Maximum Moment M_x	48 Nm [11 in-lbs]	16 Nm [142 in-lbs]
Maximum Moment M_y	72 Nm [16 in-lbs]	24 Nm [212 in-lbs]
Maximum Moment M_z	68 Nm [15 in-lbs]	22 Nm [195 in-lbs]

Capacities are per set of jaws and are not simultaneous

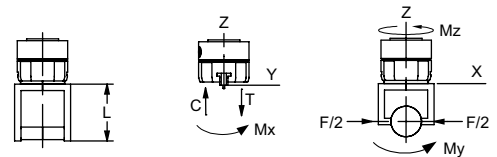
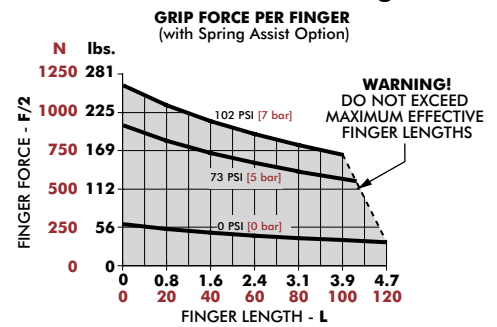

CP-6-C	Static	Dynamic
Maximum Tensile T	1340 N [301 lbs]	279 N [63 lbs]
Maximum Compressive C	1450 N [326 lbs]	279 N [63 lbs]
Maximum Moment M_x	42 Nm [372 in-lbs]	14 Nm [124 in-lbs]
Maximum Moment M_y	70 Nm [620 in-lbs]	23 Nm [204 in-lbs]
Maximum Moment M_z	64 Nm [566 in-lbs]	21 Nm [186 in-lbs]

Capacities are per set of jaws and are not simultaneous

DPDL SERIES

2-Jaw General Industrial Grippers | Features and Benefits | How To Order

Features:

- Rugged general purpose modular gripper
- High impact resistance with double wedge design
- Harsh environments with sealed rubber boot jaw option
- Thru-body mounting and multiple mounting features simplifies installation
- Multiple air ports support manifold interface using O-rings
- Purge and scavenge ports for harsh & clean environments

Applications:

- Use in machine coolant and metal chip environment applications
- High impact applications
- Paintbooths, sandblasting applications

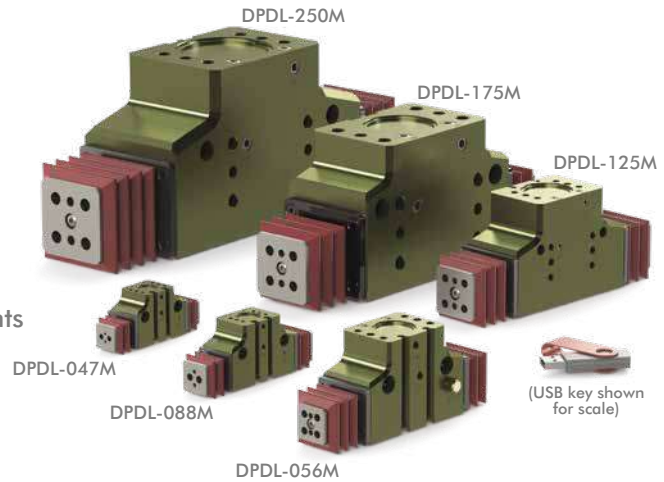

How To Order

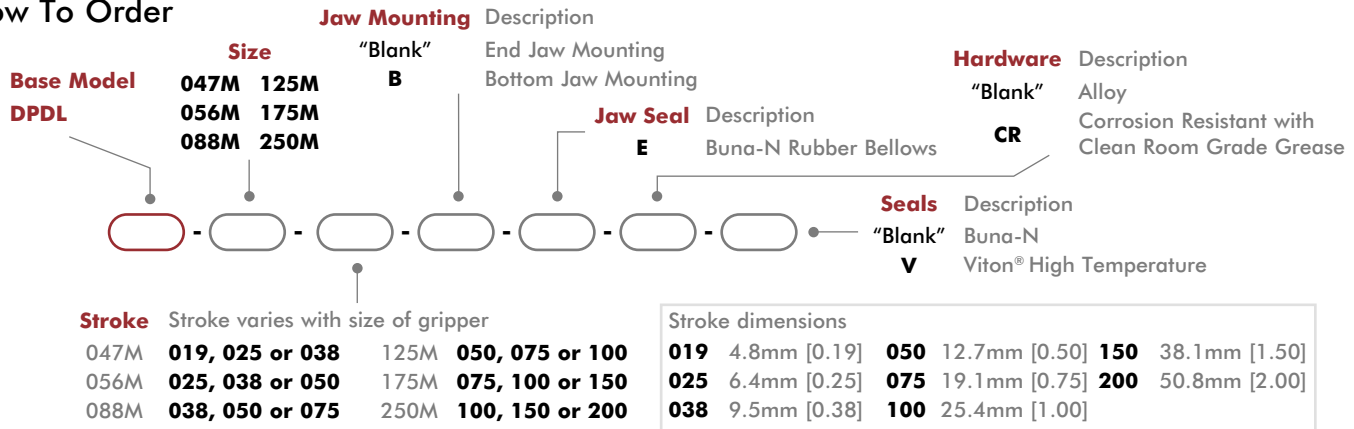

Accessories

Sensor Accessories	Model Numbers	Part Number	Qty/Unit
PNP Magneto Resistive Sensor with Quick Disconnect*	047M, 056M, 088M, 125M	OHSP-017	1-2
NPN Magneto Resistive Sensor with Quick Disconnect*	047M, 056M, 088M, 125M	OHSN-017	1-2
PNP Magneto Resistive Sensor with Quick Disconnect*	175M, 250M	OHSP-015	1-2
NPN Magneto Resistive Sensor with Quick Disconnect*	175M, 250M	OHSN-015	1-2
PNP Magneto Resistive Sensor (90° barrel) w/Qk. Disc.*	047M, 056M, 088M, 125M	OHSP-011	1-2
NPN Magneto Resistive Sensor (90° barrel) w/Qk. Disc.*	047M, 056M, 088M, 125M	OHSN-011	1-2
Quick Disconnect 2 Meter Cable Length*	All Models	CABL-010	1-2
Quick Disconnect 5 Meter Cable Length*	All Models	CABL-013	1-2

Pneumatic Accessories	Model Numbers	Part Number	Qty/Unit
Plumbing Fitting - M3 male to 3mm OD Tube Push-in Style	047M, 056M	PLFT-021	1-2
Plumbing Fitting - M3 male to 2mm ID Tube Barb Style	047M, 056M	PLFT-022	1-2
Plumbing Fitting - 1/8 NPT Male to 1/8 BSPP Female	125M, 250M	PLFT-028	1-2
Adjustable Flow Control G 1/8 Elbow - 6mm OD Push-in	125M, 250M	VLVF-005	1-2
Adjustable Flow Control M5 Elbow - 6mm OD Push-in	088M, 125M	VLVF-008	1-2
Fail Safe Valve M5	088M, 125M	OFSV-004	1
Fail Safe Valve G 1/8 (1/8 BSPP)	175M, 250M	OFSV-005	1

* Sensor and cable sold separately.

2-Jaw General Industrial Grippers | Technical Specifications

Specifications	Units	047M	056M	088M
Total Rated Grip Force F @ 100 psi	N [lbs]	62 [14]	98 [22]	222 [50]
Total Stroke	mm [in]	9.5 [0.38]	12.7 [0.50]	19.1 [0.75]
Weight	kg [lbs]	0.08 [0.19]	0.14 [0.32]	0.43 [0.95]
Pressure Range	bar [psi]	1.5-7 [20-100]		
Max. Vacuum for Scavenge Port	mm Hg [in. Hg]	200 [8]		
Max. Pressure for Purge Port	bar [psi]	1.4 [20]		
with -E Jaw Boot	bar [psi]	0.25 [4]		
Ingress Protection Class (IP)		IP66		
Displacement	cm ³ [in ³]	0.6 [0.038]	1.2 [0.074]	4.4 [0.269]
Temperature Range (Buna-N seals)	°C [°F]	-35°~80° [-30°~180°]		
Temperature Range (Viton® seals)	°C [°F]	-30°~150° [-20°~300°]		
Actuation	sec	0.20	0.25	0.30
Accuracy	mm [in]	±0.05 [±0.002]		
Repeatability	mm [in]	±0.03 [±0.001]		
Valve to Actuate Double Acting		4-way, 2-position		

Specifications	Units	125M	175M	250M
Total Rated Grip Force F @ 100 psi	N [lbs]	445 [100]	890 [200]	1779 [400]
Total Stroke	mm [in]	25.4 [1.00]	38.1 [1.50]	50.8 [2.00]
Weight	kg [lbs]	0.90 [1.99]	2.73 [6.02]	5.46 [12.04]
Pressure Range	bar [psi]	1.5-7 [20-100]		
Max. Vacuum for Scavenge Port	mm Hg [in. Hg]	200 [8]		
Max. Pressure for Purge Port	bar [psi]	1.4 [20]		
with -E Jaw Boot	bar [psi]	0.25 [4]		
Ingress Protection Class (IP)		IP66		
Displacement	cm ³ [in ³]	12.0 [0.730]	35.2 [2.150]	95.9 [5.850]
Temperature Range (Buna-N seals)	°C [°F]	-35°~80° [-30°~180°]		
Temperature Range (Viton® seals)	°C [°F]	-30°~150° [-20°~300°]		
Actuation	sec	0.50	0.70	0.90
Accuracy	mm [in]	±0.08 [±0.003]		
Repeatability	mm [in]	±0.03 [±0.001]		
Valve to Actuate Double Acting		4-way, 2-position		

DPDL-047M, 047M-B



2-Jaw General Industrial Grippers | Dimensions and Technical Specifications

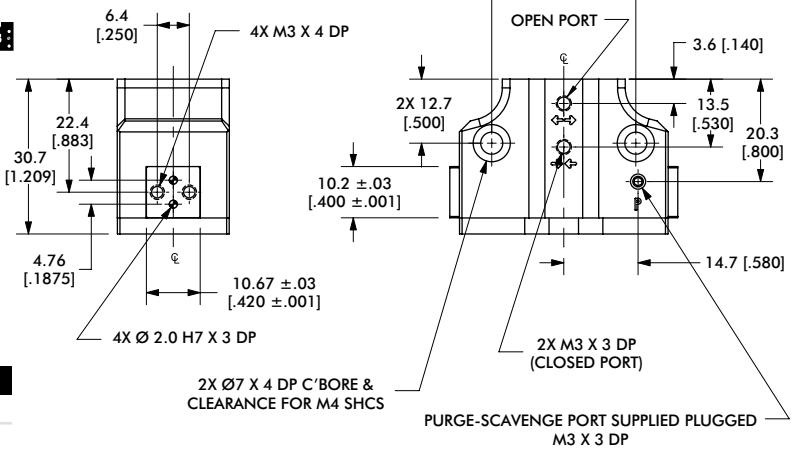
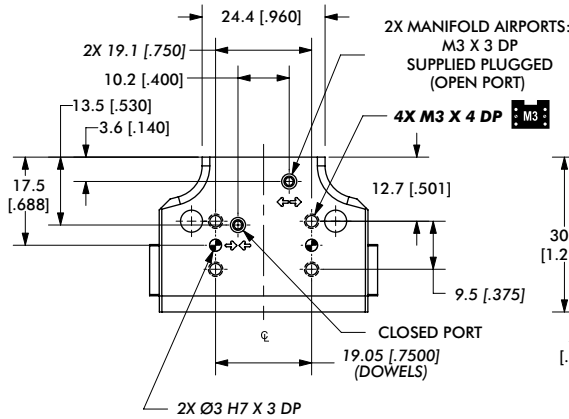
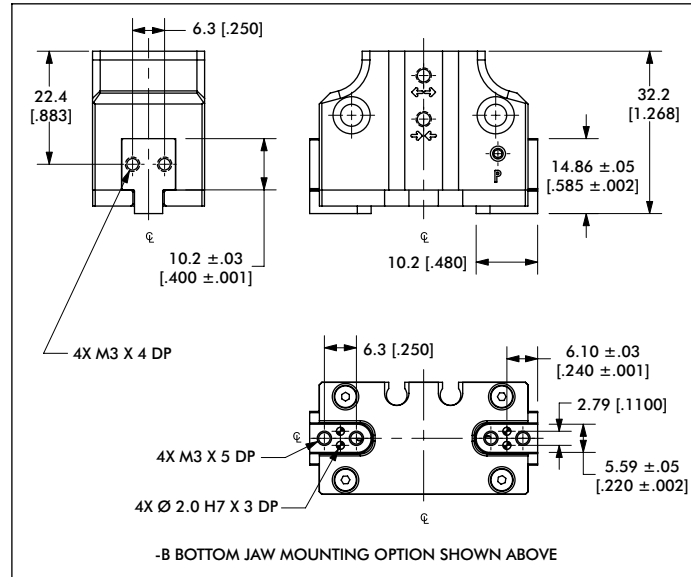
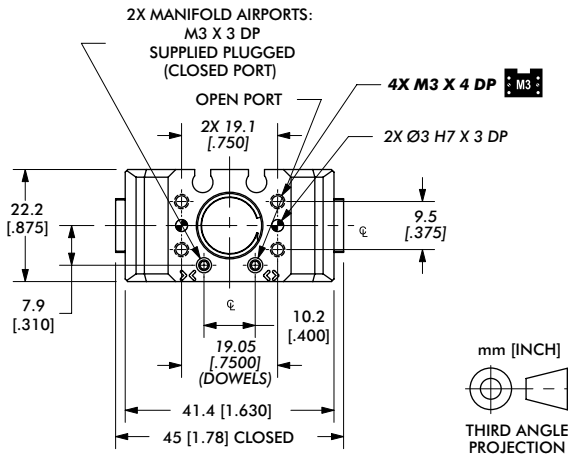

Seal Repair Kits	047M
Buna-N Seal Repair Kit	SLKT-185
Viton® Seal Repair Kit	SLKT-185V
Manifold Seal Kit (Viton® only)	SLKT-197V
Sealed Jaw Boot Replacement (1 Buna-N Boot only)	SLKT-191

Loading Information

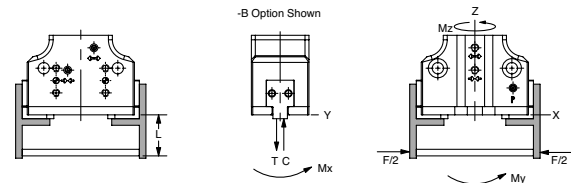
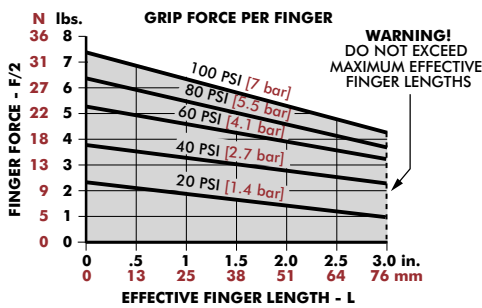

DPDL-047M	Static	Dynamic
Maximum Tensile T	445 N [100 lbs]	67 N [15 lbs]
Maximum Compressive C	668 N [150 lbs]	111 N [25 lbs]
Maximum Moment M_x	10 Nm [90 in-lbs]	2 Nm [15 in-lbs]
Maximum Moment M_y	10 Nm [90 in-lbs]	2 Nm [15 in-lbs]
Maximum Moment M_z	10 Nm [90 in-lbs]	2 Nm [15 in-lbs]

[†]Capacities are per set of jaws and are not simultaneous

DPDL-047M-B	Static	Dynamic
Maximum Tensile T	356 N [80 lbs]	53 N [12 lbs]
Maximum Compressive C	534 N [120 lbs]	89 N [20 lbs]
Maximum Moment M_x	8 Nm [72 in-lbs]	1 Nm [12 in-lbs]
Maximum Moment M_y	8 Nm [72 in-lbs]	1 Nm [12 in-lbs]
Maximum Moment M_z	8 Nm [72 in-lbs]	1 Nm [12 in-lbs]

[†]Capacities are per set of jaws and are not simultaneous

2-Jaw General Industrial Grippers | Dimensions and Technical Specifications

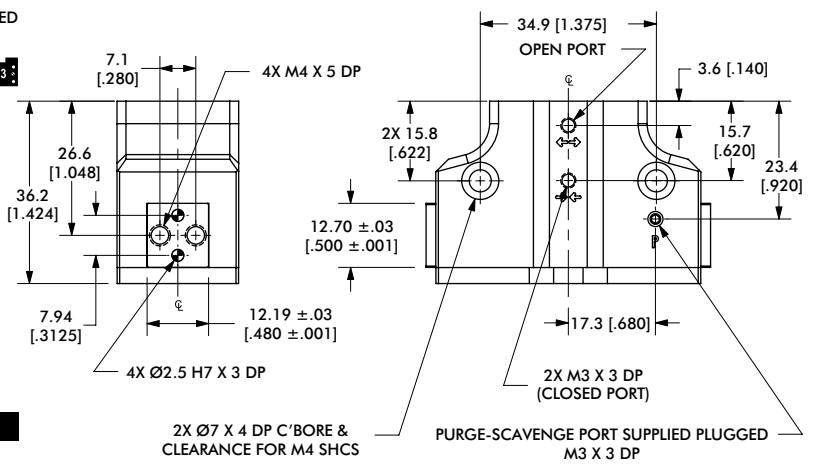
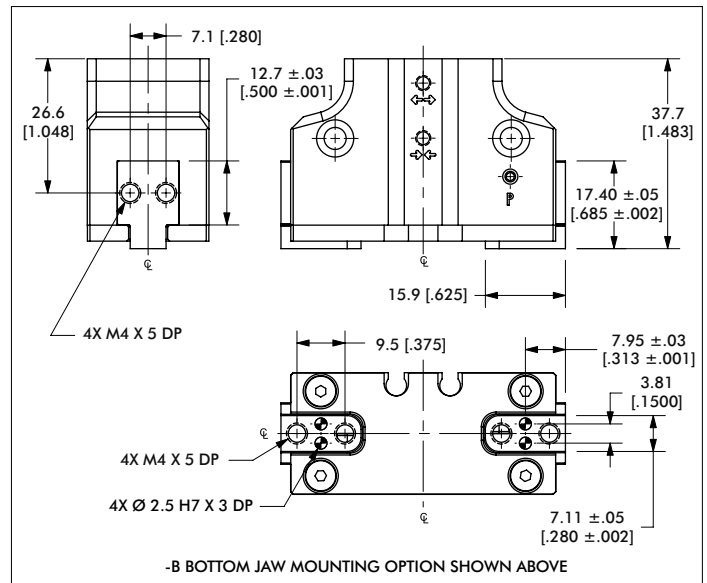
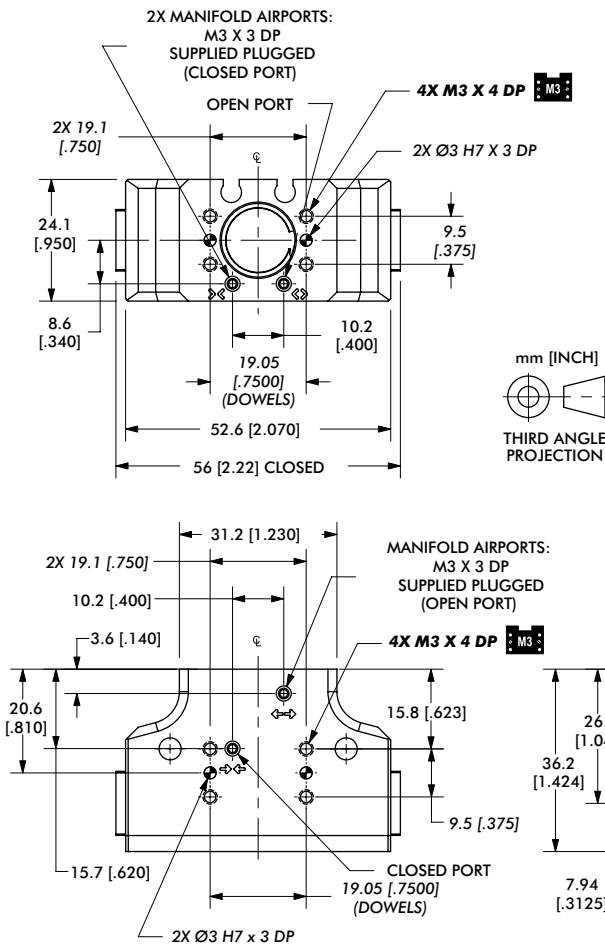

Seal Repair Kits	056M
Buna-N Seal Repair Kit	SLKT-186
Viton® Seal Repair Kit	SLKT-186V
Manifold Seal Kit (Viton® only)	SLKT-197V
Sealed Jaw Boot Replacement (1 Buna-N Boot only)	SLKT-192

Loading Information

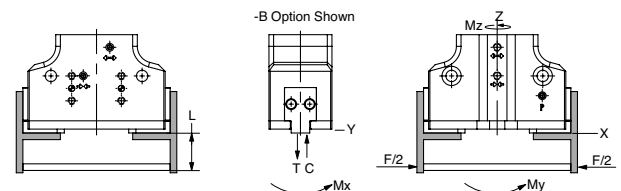
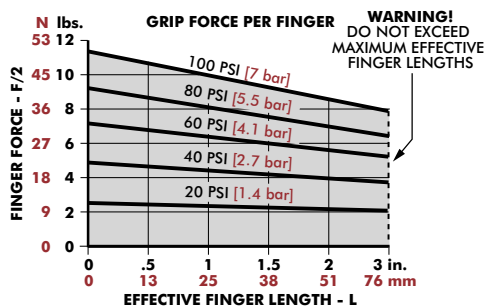

DPDL-056M	Static	Dynamic
Maximum Tensile T	556 N [125 lbs]	111 N [25 lbs]
Maximum Compressive C	1113 N [250 lbs]	111 N [25 lbs]
Maximum Moment M_x	13 Nm [115 in-lbs]	2 Nm [20 in-lbs]
Maximum Moment M_y	13 Nm [115 in-lbs]	2 Nm [20 in-lbs]
Maximum Moment M_z	13 Nm [115 in-lbs]	2 Nm [20 in-lbs]

DPDL-056M-B	Static	Dynamic
Maximum Tensile T	445 N [100 lbs]	89 N [20 lbs]
Maximum Compressive C	890 N [200 lbs]	89 N [20 lbs]
Maximum Moment M_x	10 Nm [92 in-lbs]	2 Nm [16 in-lbs]
Maximum Moment M_y	10 Nm [92 in-lbs]	2 Nm [16 in-lbs]
Maximum Moment M_z	10 Nm [92 in-lbs]	2 Nm [16 in-lbs]

*Capacities are per set of jaws and are not simultaneous

*Capacities are per set of jaws and are not simultaneous

DPDL-088M, 088M-B



2-Jaw General Industrial Grippers | Dimensions and Technical Specifications

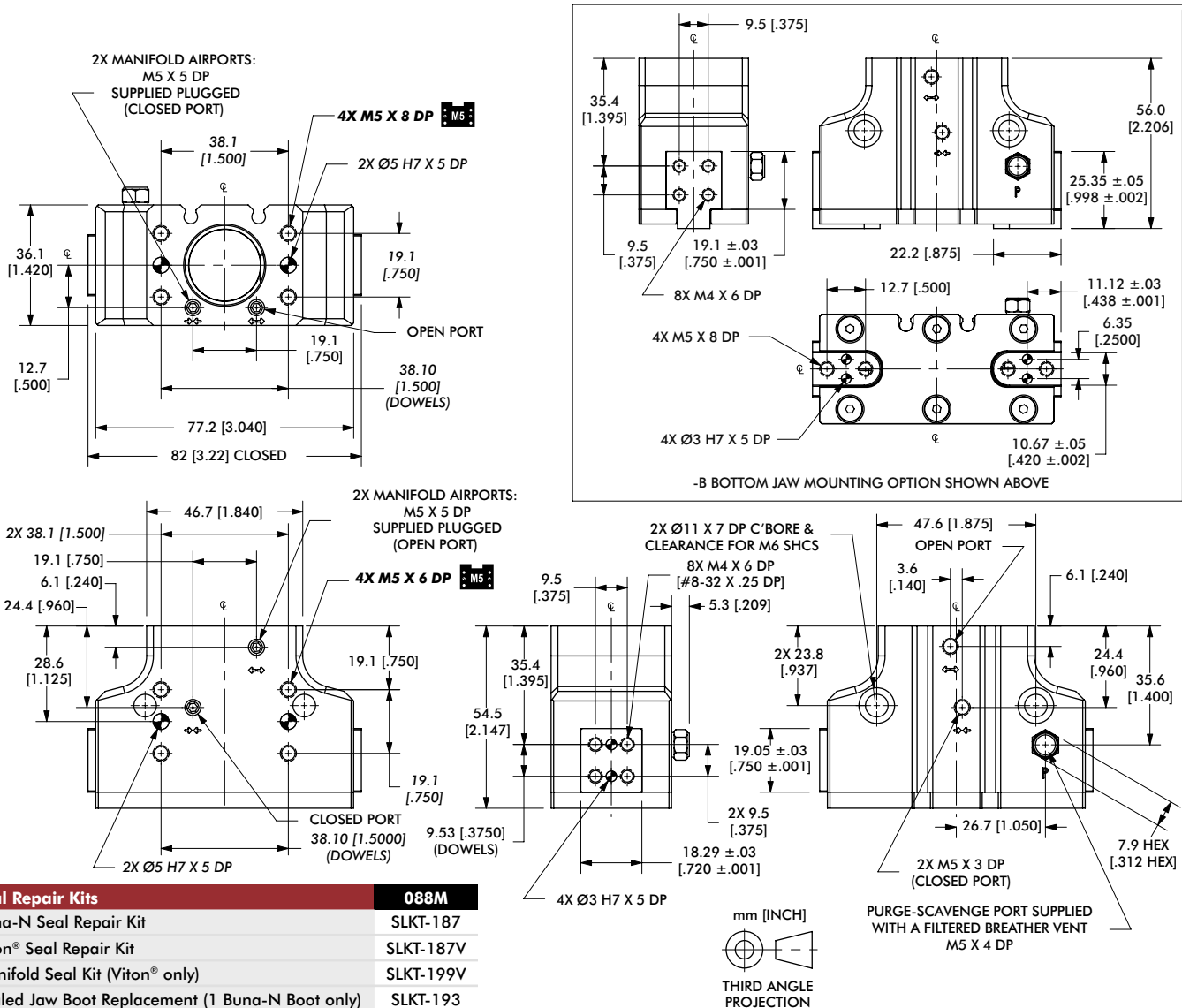

Loading Information

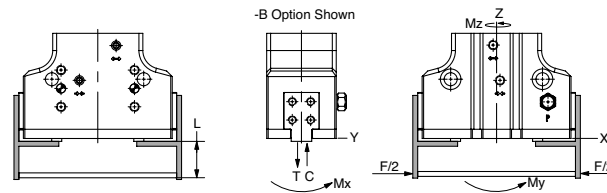
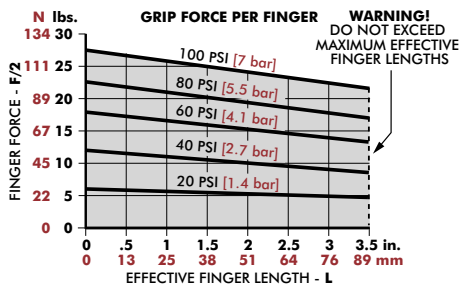

DPDL-088M	Static	Dynamic
Maximum Tensile T	1558 N [350 lbs]	178 N [40 lbs]
Maximum Compressive C	2893 N [650 lbs]	178 N [40 lbs]
Maximum Moment M_x	28 Nm [250 in-lbs]	5 Nm [40 in-lbs]
Maximum Moment M_y	28 Nm [250 in-lbs]	5 Nm [40 in-lbs]
Maximum Moment M_z	28 Nm [250 in-lbs]	5 Nm [40 in-lbs]

*Capacities are per set of jaws and are not simultaneous

DPDL-088M-B	Static	Dynamic
Maximum Tensile T	1246 N [280 lbs]	142 N [32 lbs]
Maximum Compressive C	2314 N [520 lbs]	142 N [32 lbs]
Maximum Moment M_x	23 Nm [200 in-lbs]	4 Nm [32 in-lbs]
Maximum Moment M_y	23 Nm [200 in-lbs]	4 Nm [32 in-lbs]
Maximum Moment M_z	23 Nm [200 in-lbs]	4 Nm [32 in-lbs]

*Capacities are per set of jaws and are not simultaneous

2-Jaw General Industrial Grippers | Dimensions and Technical Specifications

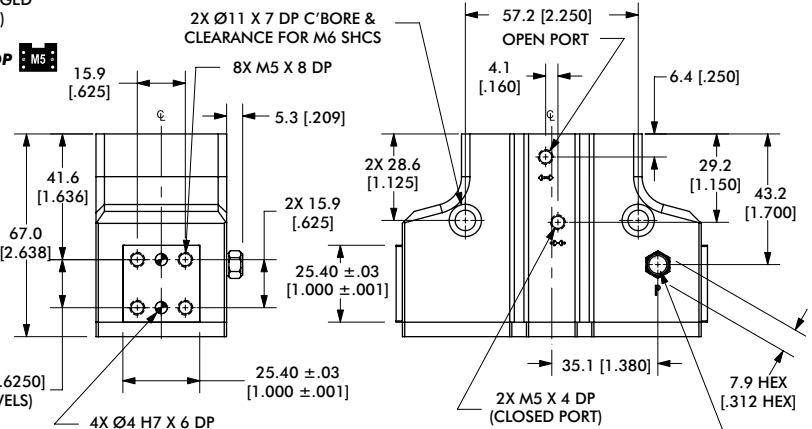
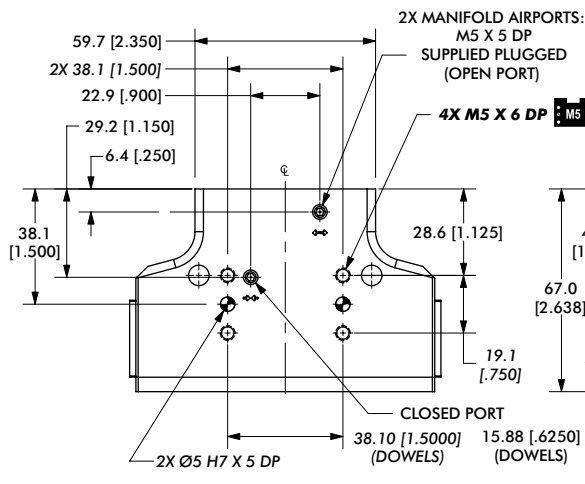
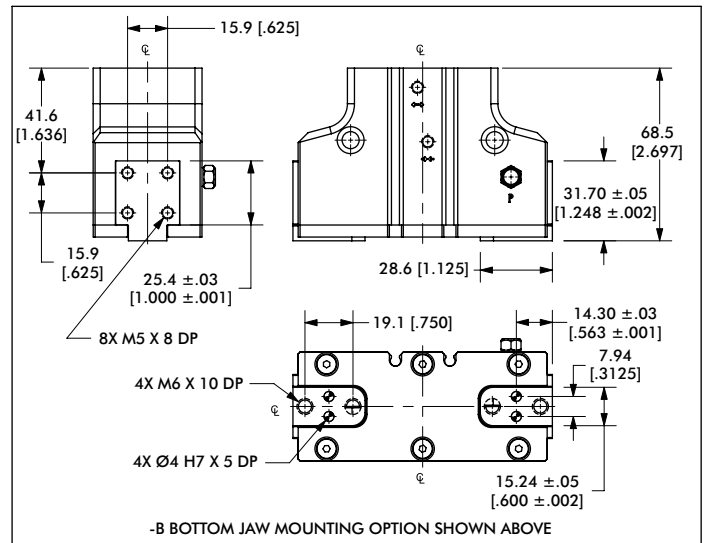
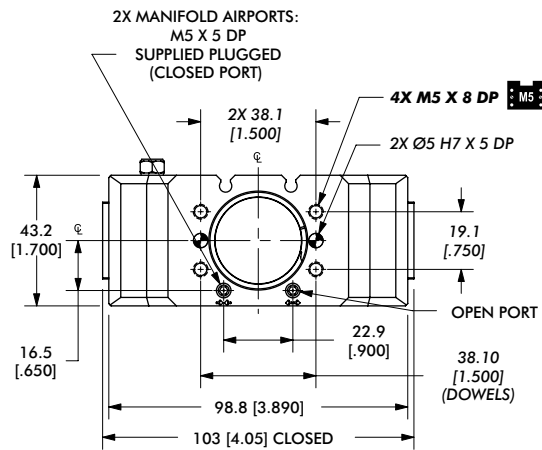

Seal Repair Kits	125M
Buna-N Seal Repair Kit	SLKT-188
Viton® Seal Repair Kit	SLKT-188V
Manifold Seal Kit (Viton® only)	SLKT-199V
Sealed Jaw Boot Replacement (1 Buna-N Boot only)	SLKT-194

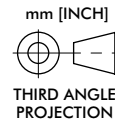

PURGE-SCAVENGE PORT SUPPLIED WITH A FILTERED BREATHER VENT M5 X 4 DP

Loading Information

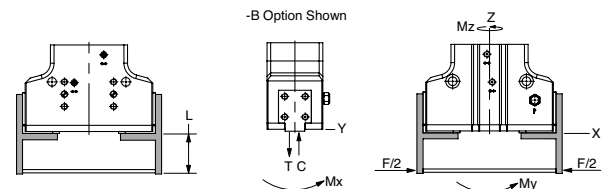
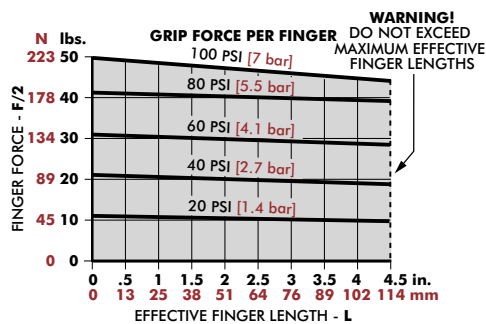

DPDL-125M	Static	Dynamic
Maximum Tensile T	3004 N [675 lbs]	401 N [90 lbs]
Maximum Compressive C	5785 N [1300 lbs]	401 N [90 lbs]
Maximum Moment M_x	73 Nm [650 in-lbs]	12 Nm [110 in-lbs]
Maximum Moment M_y	73 Nm [650 in-lbs]	12 Nm [110 in-lbs]
Maximum Moment M_z	73 Nm [650 in-lbs]	12 Nm [110 in-lbs]

*Capacities are per set of jaws and are not simultaneous

DPDL-125M-B	Static	Dynamic
Maximum Tensile T	2403 N [540 lbs]	320 N [72 lbs]
Maximum Compressive C	4628 N [1040 lbs]	320 N [72 lbs]
Maximum Moment M_x	59 Nm [520 in-lbs]	10 Nm [88 in-lbs]
Maximum Moment M_y	59 Nm [520 in-lbs]	10 Nm [88 in-lbs]
Maximum Moment M_z	59 Nm [520 in-lbs]	10 Nm [88 in-lbs]

*Capacities are per set of jaws and are not simultaneous

DPDL-175M, 175M-B



2-Jaw General Industrial Grippers | Dimensions and Technical Specifications

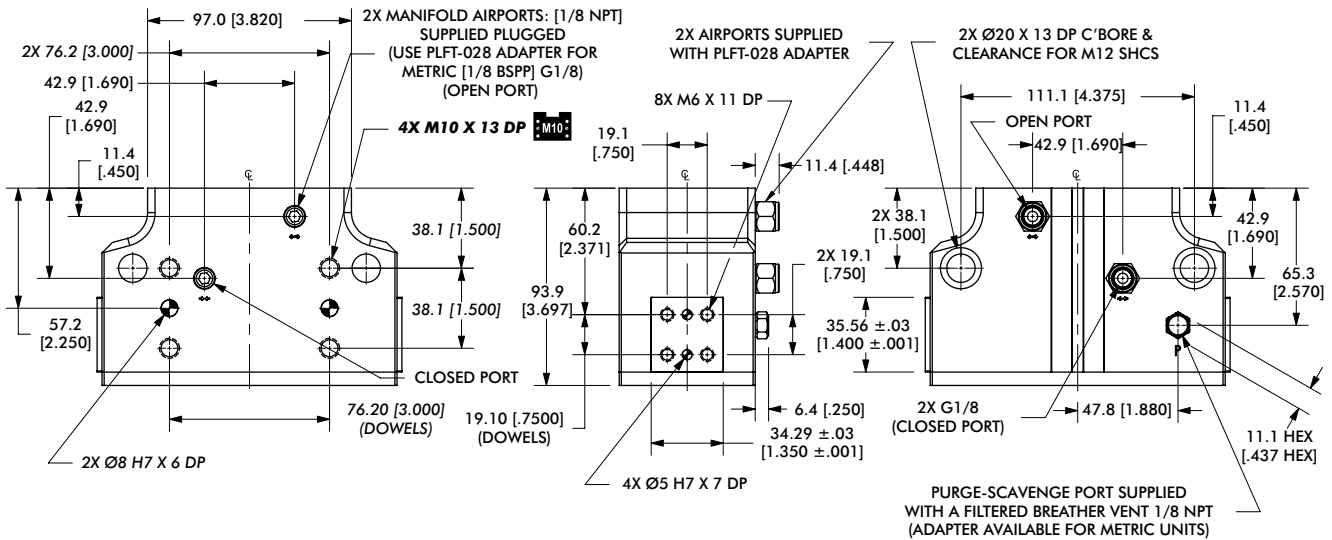
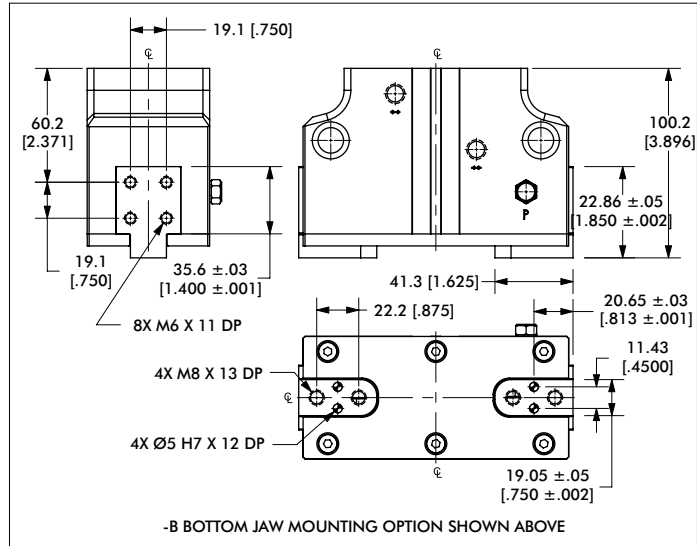
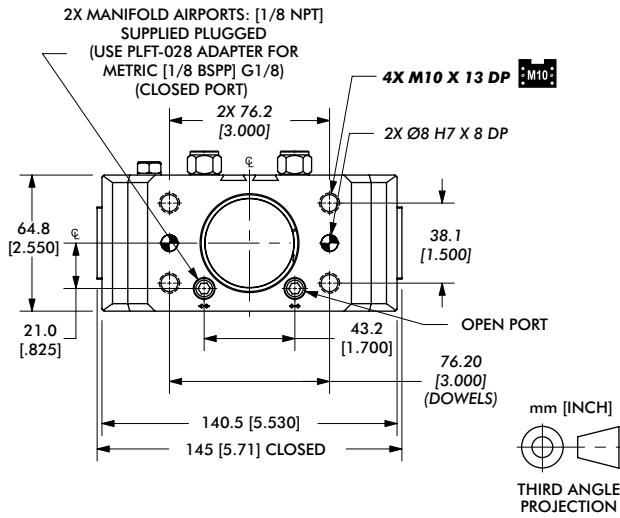

Loading Information

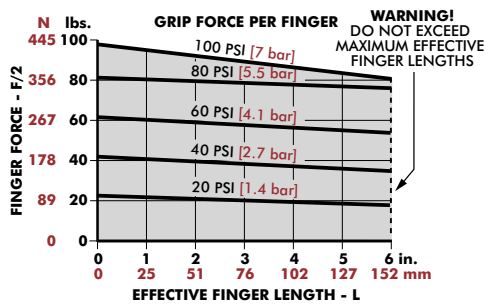

Seal Repair Kits	175M
Buna-N Seal Repair Kit	SLKT-189
Viton® Seal Repair Kit	SLKT-189V
Manifold Seal Kit (Viton® only)	SLKT-201V
Sealed Jaw Boot Replacement (1 Buna-N Boot only)	SLKT-195

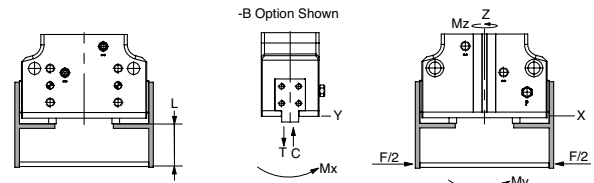

DPDL-175M	Static	Dynamic
Maximum Tensile T	5118 N [1150 lbs]	779 N [175 lbs]
Maximum Compressive C	10235 N [2300 lbs]	779 N [175 lbs]
Maximum Moment M_x	130 Nm [1150 in-lbs]	22 Nm [190 in-lbs]
Maximum Moment M_y	130 Nm [1150 in-lbs]	22 Nm [190 in-lbs]
Maximum Moment M_z	130 Nm [1150 in-lbs]	22 Nm [190 in-lbs]

*Capacities are per set of jaws and are not simultaneous

DPDL-175M-B	Static	Dynamic
Maximum Tensile T	4094 N [920 lbs]	623 N [140 lbs]
Maximum Compressive C	8188 N [1840 lbs]	623 N [140 lbs]
Maximum Moment M_x	104 Nm [920 in-lbs]	17 Nm [152 in-lbs]
Maximum Moment M_y	104 Nm [920 in-lbs]	17 Nm [152 in-lbs]
Maximum Moment M_z	104 Nm [920 in-lbs]	17 Nm [152 in-lbs]

*Capacities are per set of jaws and are not simultaneous

2-Jaw General Industrial Grippers | Dimensions and Technical Specifications

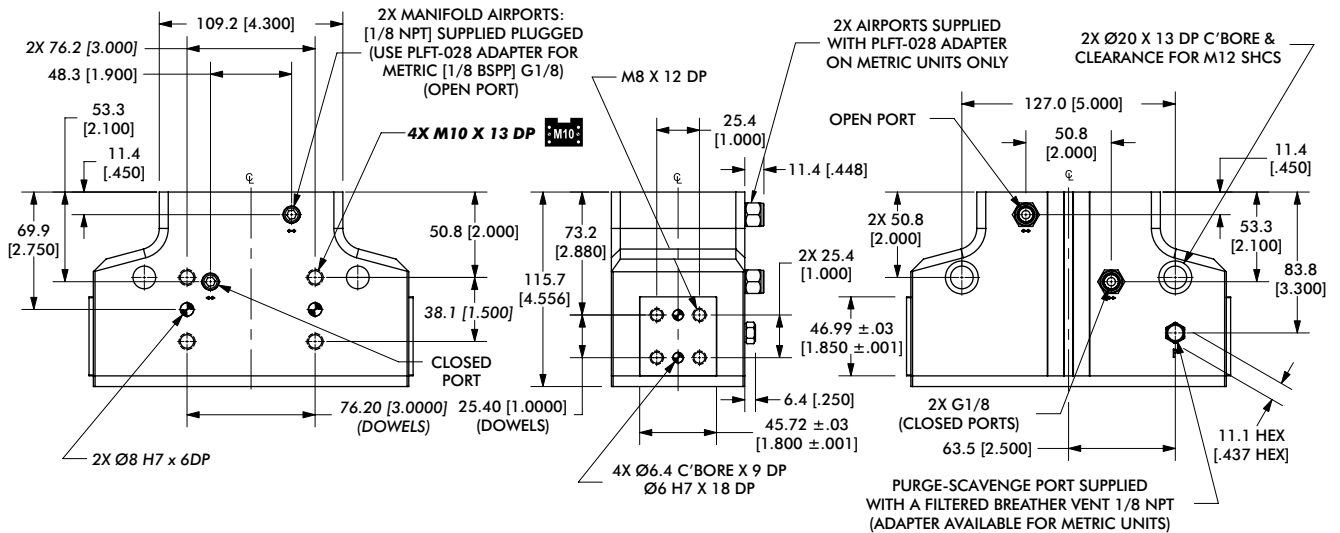
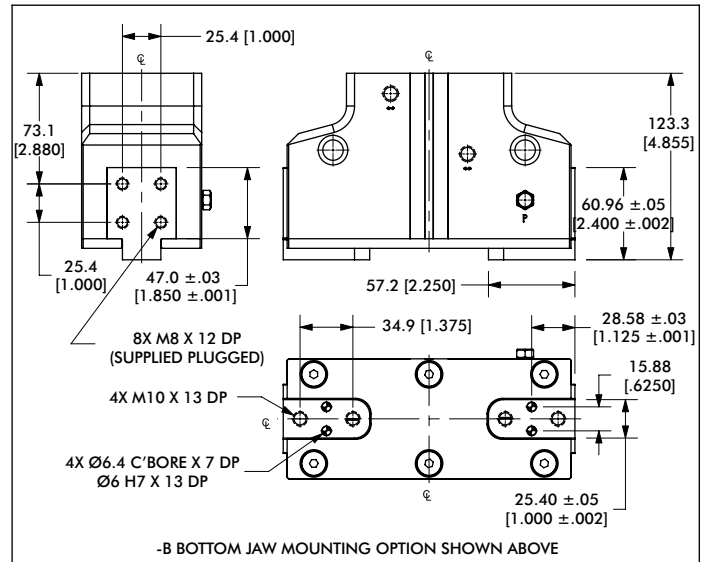
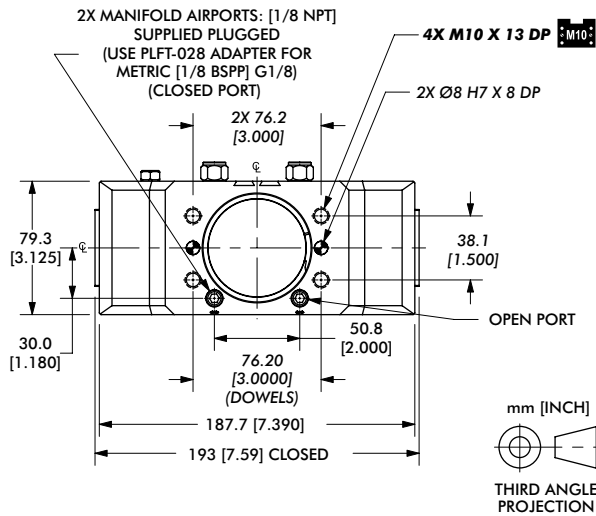

Loading Information

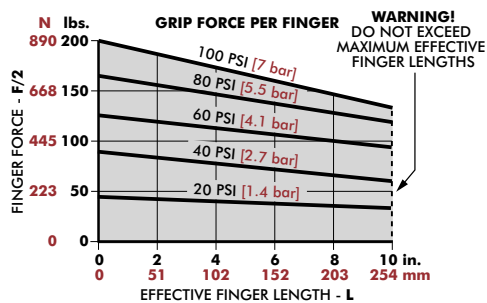

Seal Repair Kits	250M
Buna-N Seal Repair Kit	SLKT-190
Viton® Seal Repair Kit	SLKT-190V
Manifold Seal Kit (Viton® only)	SLKT-201V
Sealed Jaw Boot Replacement (1 Buna-N Boot only)	SLKT-196

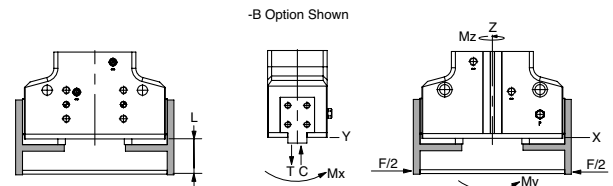

DPDL-250M	Static	Dynamic
Maximum Tensile T	9568 N [2150 lbs]	1224 N [275 lbs]
Maximum Compressive C	19135 N [4300 lbs]	1224 N [275 lbs]
Maximum Moment M_x	339 Nm [3000 in-lbs]	40 Nm [350 in-lbs]
Maximum Moment M_y	339 Nm [3000 in-lbs]	40 Nm [350 in-lbs]
Maximum Moment M_z	339 Nm [3000 in-lbs]	40 Nm [350 in-lbs]

*Capacities are per set of jaws and are not simultaneous

DPDL-250M-B	Static	Dynamic
Maximum Tensile T	7654 N [1720 lbs]	979 N [220 lbs]
Maximum Compressive C	15308 N [3440 lbs]	979 N [220 lbs]
Maximum Moment M_x	271 Nm [2400 in-lbs]	32 Nm [280 in-lbs]
Maximum Moment M_y	271 Nm [2400 in-lbs]	32 Nm [280 in-lbs]
Maximum Moment M_z	271 Nm [2400 in-lbs]	32 Nm [280 in-lbs]

*Capacities are per set of jaws and are not simultaneous

DPDS SERIES

2-Jaw General Industrial Grippers | Features and Benefits | How To Order

Features:

- Rugged general purpose modular gripper
- High impact resistant with double wedge design
- Finger mounting on end or bottom of jaws
- Thru-body mounting and multiple mounting features simplifies installation
- Multiple air ports support manifold interface using O-rings
- Purge/scavenge ports for harsh & clean environments
- Corrosion resistance hardware option

Applications:

- Compact, robust gripper for use in confined spaces requiring a high grip force
- Multiple part gripping using manifold feature to create gripper arrays
- Long finger gripping applications



How To Order

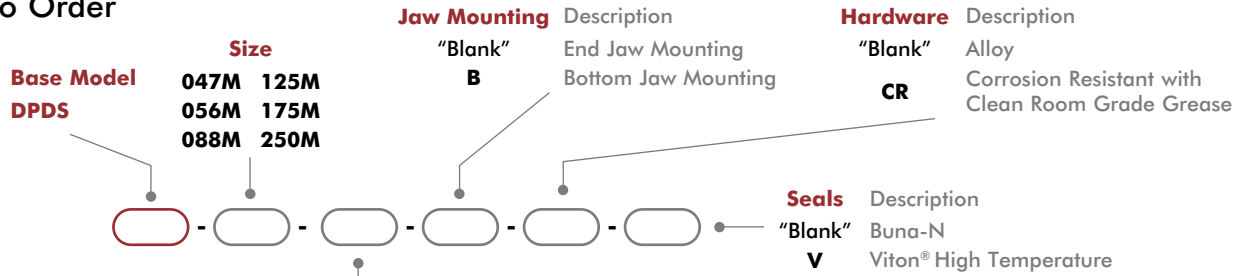

Stroke Stroke varies with size of gripper

047M	006, 009 or 013	125M	019, 025 or 038
056M	009, 013 or 019	175M	025, 038 or 050
088M	013, 019 or 025	250M	038, 050 or 075

Stroke dimensions

006	1.6mm [0.06]	019	4.8mm [0.19]	050	12.7mm [0.50]
009	2.4mm [0.09]	025	6.4mm [0.25]	075	19.1mm [0.75]
013	3.2mm [0.13]	038	9.5mm [0.38]		

Accessories

Sensor Accessories	Model Numbers	Part Number	Qty/Unit
PNP Magneto Resistive Sensor with Quick Disconnect*	047M, 056M, 088M, 125M	OHSP-017	1-2
NPN Magneto Resistive Sensor with Quick Disconnect*	047M, 056M, 088M, 125M	OHSN-017	1-2
PNP Magneto Resistive Sensor with Quick Disconnect*	175M, 250M	OHSP-015	1-2
NPN Magneto Resistive Sensor with Quick Disconnect*	175M, 250M	OHSN-015	1-2
PNP Magneto Resistive Sensor (90° barrel) w/Qk. Disc.*	047M, 056M, 088M, 125M	OHSP-011	1-2
NPN Magneto Resistive Sensor (90° barrel) w/Qk. Disc.*	047M, 056M, 088M, 125M	OHSN-011	1-2
Quick Disconnect 2 Meter Cable Length*	All Models	CABL-010	1-2
Quick Disconnect 5 Meter Cable Length*	All Models	CABL-013	1-2

Pneumatic Accessories	Model Numbers	Part Number	Qty/Unit
Plumbing Fitting - M3 male to 3mm OD Tube Push-in Style	047M, 056M	PLFT-021	1-2
Plumbing Fitting - M3 male to 2mm ID Tube Barb Style	047M, 056M	PLFT-022	1-2
Plumbing Fitting - 1/8 NPT Male to 1/8 BSPP Female	125M, 250M	PLFT-028	1-2
Adjustable Flow Control G 1/8 Elbow - 6mm OD Push-in	125M, 250M	VLVF-005	1-2
Adjustable Flow Control M5 Elbow - 6mm OD Push-in	088M, 125M	VLVF-008	1-2
Fail Safe Valve M5	088M, 125M	OFSV-004	1
Fail Safe Valve G 1/8 (1/8 BSPP)	175M, 250M	OFSV-005	1

*Sensor and cable sold separately.

2-Jaw General Industrial Grippers | Technical Specifications

Specifications	Units	047M	056M	088M
Total Rated Grip Force F @ 100 psi	N [lbs]	62 [14]	98 [22]	222 [50]
Total Stroke	mm [in]	3.2 [0.13]	4.8 [0.19]	6.4 [0.25]
Weight	kg [lbs]	0.086 [0.04]	0.155 [0.07]	0.23 [0.51]
Pressure Range	bar [psi]	1.5-7 [20-100]		
Max. Vacuum for Scavenge Port	mm Hg [in. Hg]	200 [8]		
Max. Pressure for Purge Port	bar [psi]	1.4 [20]		
Ingress Protection Class (IP)		IP54		
Displacement	cm ³ [in ³]	0.2 [0.013]	0.5 [0.028]	1.5 [0.090]
Temperature Range (Buna-N seals)	°C [°F]	-35°~80° [-30°~180°]		
Temperature Range (Viton® seals)	°C [°F]	-30°~150° [-20°~300°]		
Actuation	sec	0.13	0.16	0.20
Accuracy	mm [in]	±0.05 [±0.002]		
Repeatability	mm [in]	±0.03 [±0.001]		
Valve to Actuate Double Acting		4-way, 2-position		

Specifications	Units	125M	175M	250M
Total Rated Grip Force F @ 100 psi	N [lbs]	445 [100]	890 [200]	1779 [400]
Total Stroke	mm [in]	9.5 [0.38]	12.7 [0.50]	19.1 [0.75]
Weight	kg [lbs]	0.46 [1.03]	1.68 [3.70]	2.76 [6.08]
Pressure Range	bar [psi]	1.5-7 [20-100]		
Max. Vacuum for Scavenge Port	mm Hg [in. Hg]	200 [8]		
Max. Pressure for Purge Port	bar [psi]	1.4 [20]		
Ingress Protection Class (IP)		IP54		
Displacement	cm ³ [in ³]	4.5 [0.274]	11.7 [0.717]	36.0 [2.194]
Temperature Range (Buna-N seals)	°C [°F]	-35°~80° [-30°~180°]		
Temperature Range (Viton® seals)	°C [°F]	-30°~150° [-20°~300°]		
Actuation	sec	0.30	0.40	0.50
Accuracy	mm [in]	±0.08 [±0.003]		
Repeatability	mm [in]	±0.03 [±0.001]		
Valve to Actuate Double Acting		4-way, 2-position		

DPDS-047M, 047M-B



2-Jaw General Industrial Grippers | Dimensions and Technical Specifications

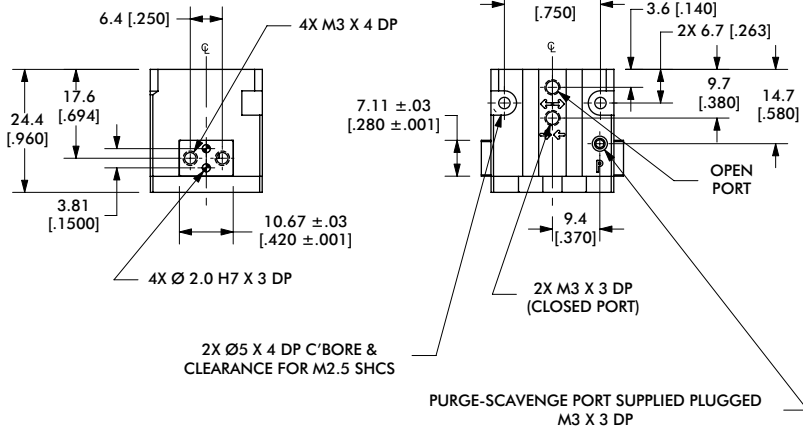
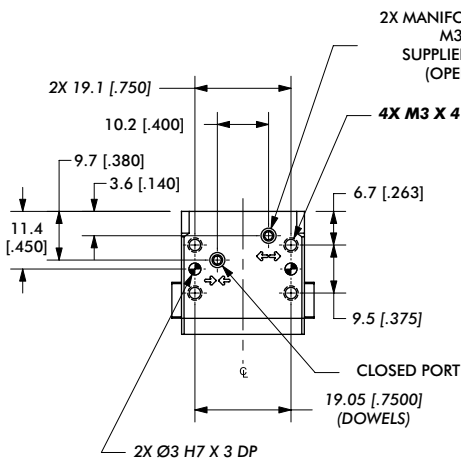
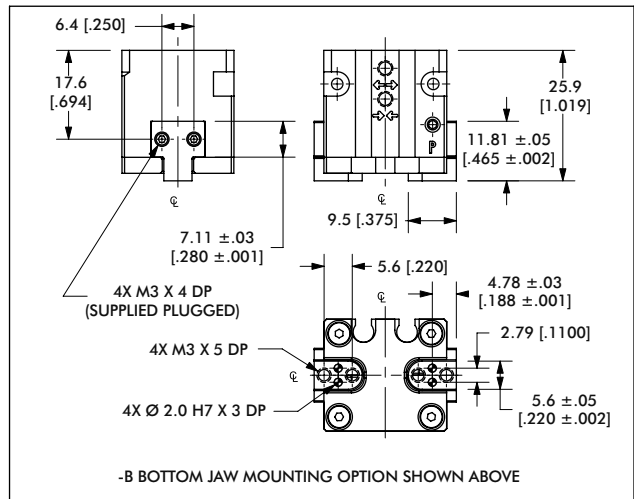
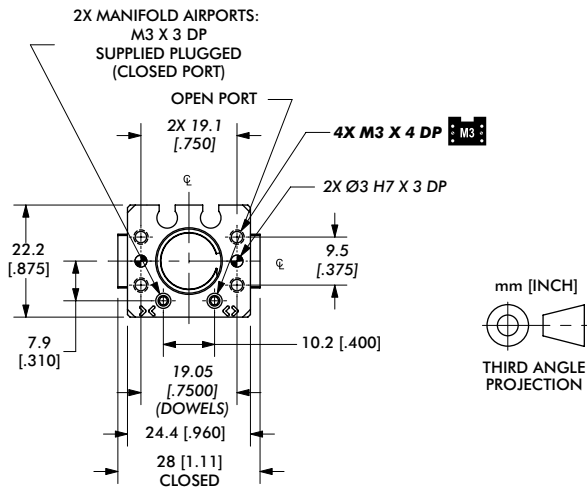

Seal Repair Kits	047M
Buna-N Seal Repair Kit	SLKT-185
Viton® Seal Repair Kit	SLKT-185V
Manifold Seal Kit (Viton® only)	SLKT-197V

Loading Information

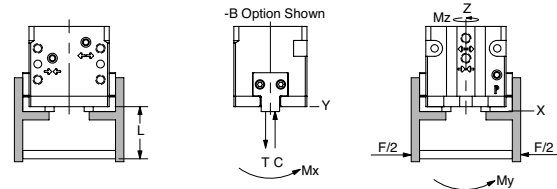
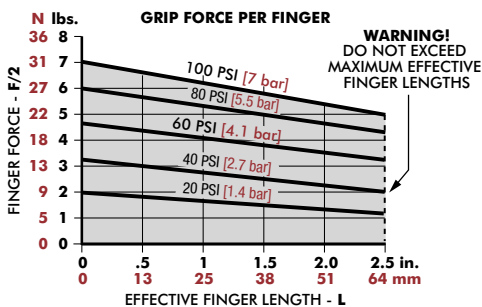

DPDS-047M	Static	Dynamic
Maximum Tensile T	134 N [30 lbs]	27 N [6 lbs]
Maximum Compressive C	223 N [50 lbs]	45 N [10 lbs]
Maximum Moment M_x	2 Nm [20 in-lbs]	0.6 Nm [5 in-lbs]
Maximum Moment M_y	2 Nm [20 in-lbs]	0.6 Nm [5 in-lbs]
Maximum Moment M_z	2 Nm [20 in-lbs]	0.6 Nm [5 in-lbs]

*Capacities are per set of jaws and are not simultaneous

DPDS-047M-B	Static	Dynamic
Maximum Tensile T	107 N [24 lbs]	22 N [5 lbs]
Maximum Compressive C	178 N [40 lbs]	36 N [8 lbs]
Maximum Moment M_x	2 Nm [16 in-lbs]	0.5 Nm [4 in-lbs]
Maximum Moment M_y	2 Nm [16 in-lbs]	0.5 Nm [4 in-lbs]
Maximum Moment M_z	2 Nm [16 in-lbs]	0.5 Nm [4 in-lbs]

*Capacities are per set of jaws and are not simultaneous

2-Jaw General Industrial Grippers | Dimensions and Technical Specifications

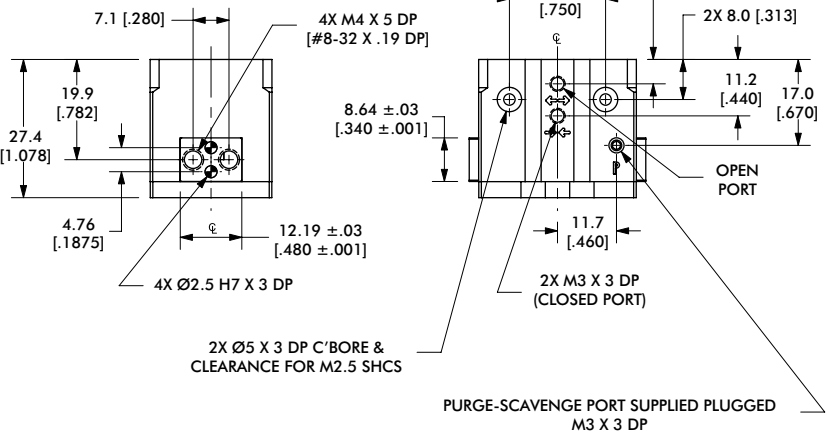
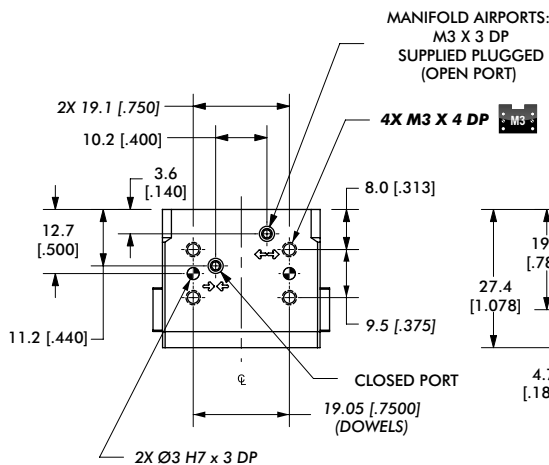
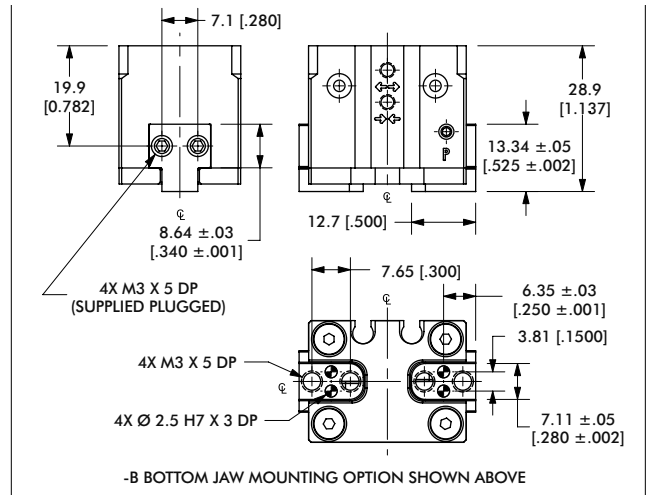
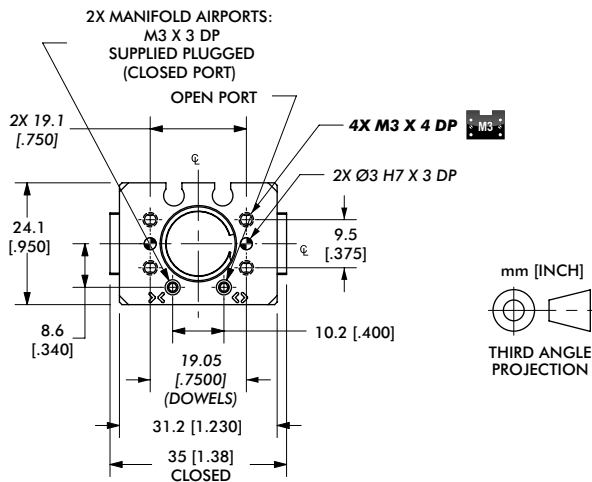

Seal Repair Kits	056M
Buna-N Seal Repair Kit	SLKT-186
Viton® Seal Repair Kit	SLKT-186V
Manifold Seal Kit (Viton® only)	SLKT-197V

Loading Information

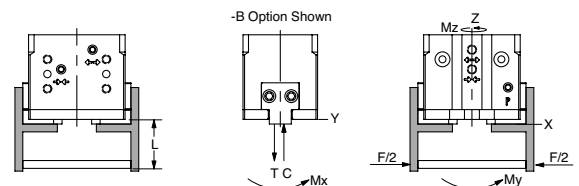
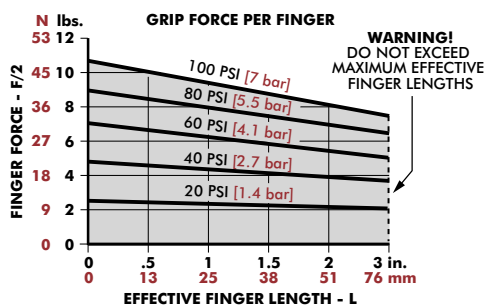

DPDS-056M	Static	Dynamic
Maximum Tensile T	267 N [60 lbs]	45 N [10 lbs]
Maximum Compressive C	401 N [90 lbs]	67 N [15 lbs]
Maximum Moment M_x	5 Nm [40 in-lbs]	0.8 Nm [7 in-lbs]
Maximum Moment M_y	5 Nm [40 in-lbs]	0.8 Nm [7 in-lbs]
Maximum Moment M_z	5 Nm [40 in-lbs]	0.8 Nm [7 in-lbs]

†Capacities are per set of jaws and are not simultaneous

DPDS-056M-B	Static	Dynamic
Maximum Tensile T	214 N [48 lbs]	36 N [8 lbs]
Maximum Compressive C	320 N [72 lbs]	53 N [12 lbs]
Maximum Moment M_x	4 Nm [32 in-lbs]	1 Nm [6 in-lbs]
Maximum Moment M_y	4 Nm [32 in-lbs]	1 Nm [6 in-lbs]
Maximum Moment M_z	4 Nm [32 in-lbs]	1 Nm [6 in-lbs]

†Capacities are per set of jaws and are not simultaneous

DPDS-088M, 088M-B



2-Jaw General Industrial Grippers | Dimensions and Technical Specifications

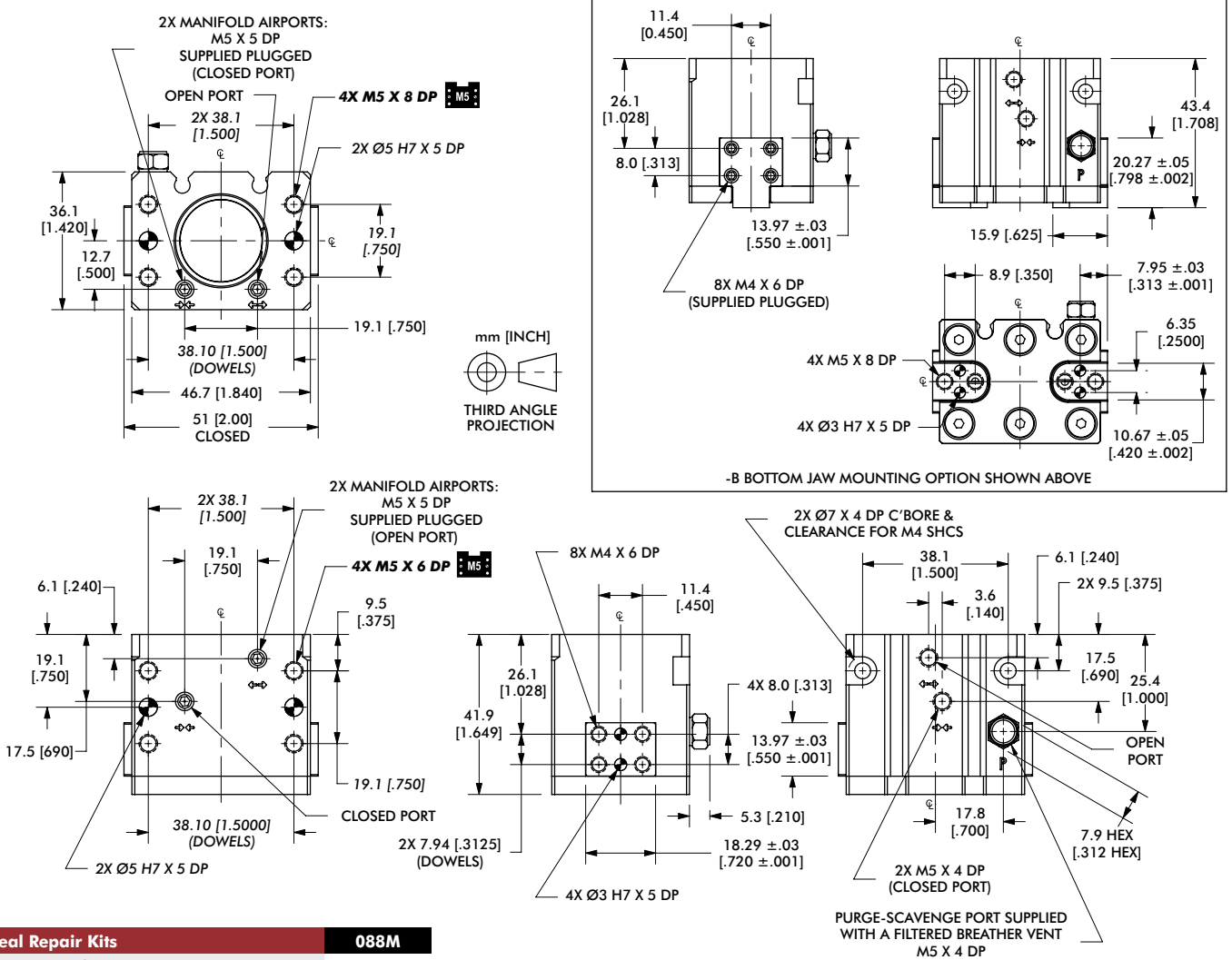

Seal Repair Kits	088M
Buna-N Seal Repair Kit	SLKT-187
Viton® Seal Repair Kit	SLKT-187V
Manifold Seal Kit (Viton® only)	SLKT-199V

Loading Information

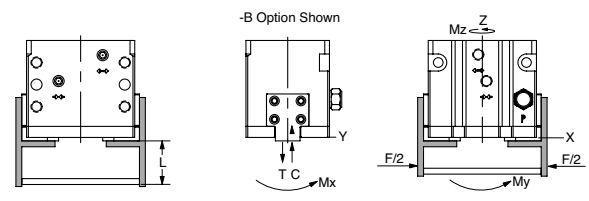
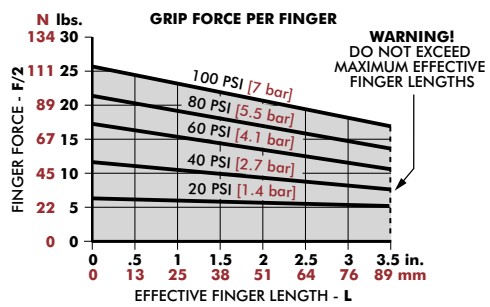

DPDS-088M	Static	Dynamic
Maximum Tensile T	614 N [138 lbs]	111 N [25 lbs]
Maximum Compressive C	1224 N [275 lbs]	111 N [25 lbs]
Maximum Moment M_x	14 Nm [120 in-lbs]	2 Nm [20 in-lbs]
Maximum Moment M_y	14 Nm [120 in-lbs]	2 Nm [20 in-lbs]
Maximum Moment M_z	14 Nm [120 in-lbs]	2 Nm [20 in-lbs]

DPDS-088M-B	Static	Dynamic
Maximum Tensile T	490 N [110 lbs]	89 N [20 lbs]
Maximum Compressive C	979 N [220 lbs]	89 N [20 lbs]
Maximum Moment M_x	11 Nm [96 in-lbs]	2 Nm [16 in-lbs]
Maximum Moment M_y	11 Nm [96 in-lbs]	2 Nm [16 in-lbs]
Maximum Moment M_z	11 Nm [96 in-lbs]	2 Nm [16 in-lbs]

*Capacities are per set of jaws and are not simultaneous

*Capacities are per set of jaws and are not simultaneous



2-Jaw General Industrial Grippers | Dimensions and Technical Specifications

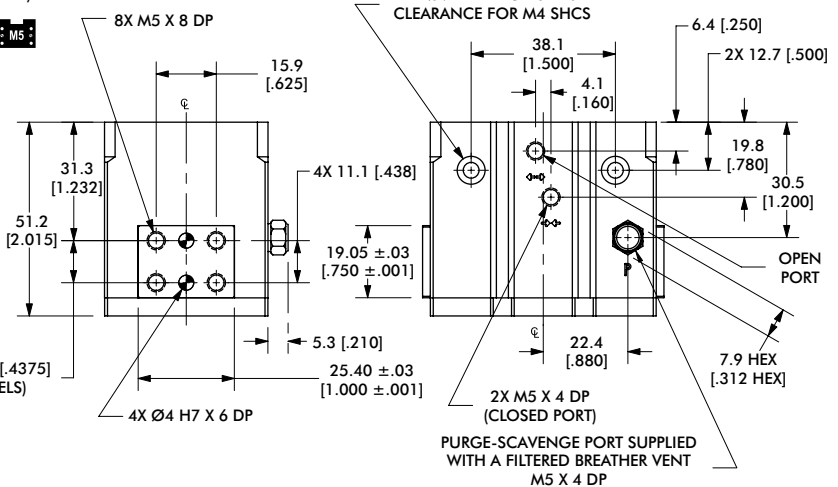
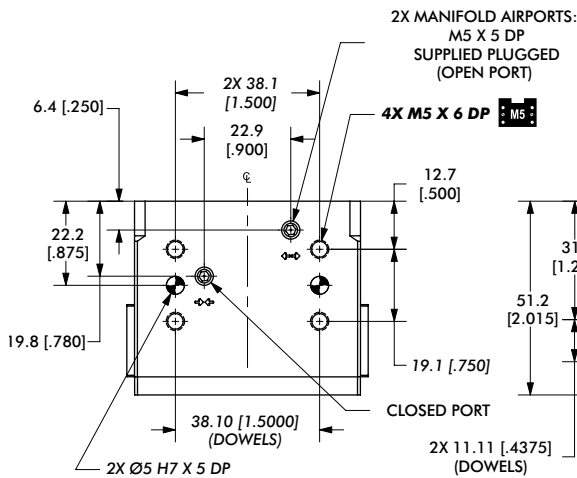
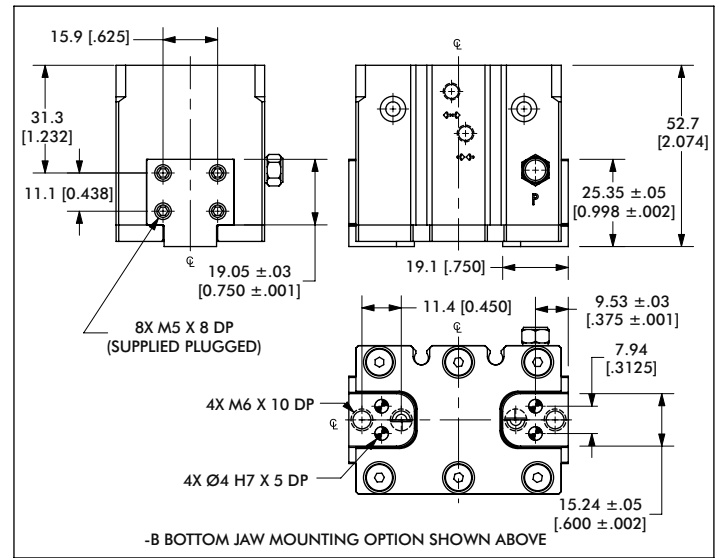
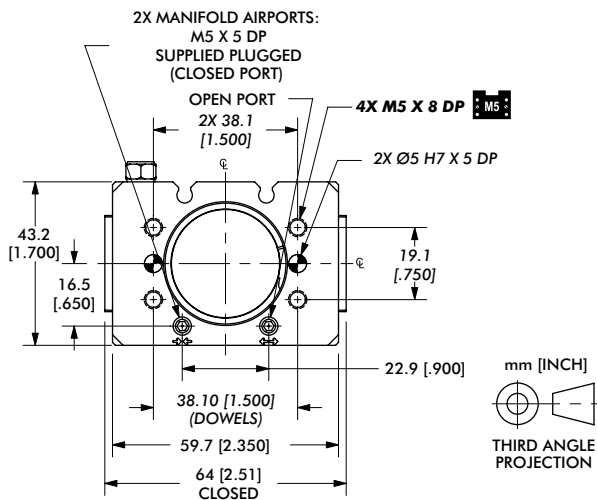

Seal Repair Kits	056M
Buna-N Seal Repair Kit	SLKT-188
Viton® Seal Repair Kit	SLKT-188V
Manifold Seal Kit (Viton® only)	SLKT-199V

Loading Information

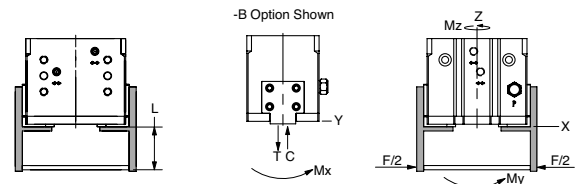
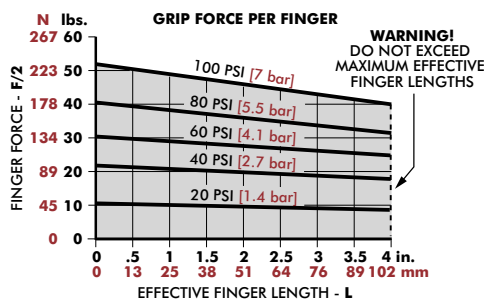

DPDS-125M	Static	Dynamic
Maximum Tensile T	2225 N [500 lbs]	289 N [65 lbs]
Maximum Compressive C	4228 N [950 lbs]	289 N [65 lbs]
Maximum Moment M_x	48 Nm [425 in-lbs]	8 Nm [70 in-lbs]
Maximum Moment M_y	48 Nm [425 in-lbs]	8 Nm [70 in-lbs]
Maximum Moment M_z	48 Nm [425 in-lbs]	8 Nm [70 in-lbs]

†Capacities are per set of jaws and are not simultaneous

DPDS-125M-B	Static	Dynamic
Maximum Tensile T	1780 N [400 lbs]	231 N [52 lbs]
Maximum Compressive C	3382 N [760 lbs]	231 N [52 lbs]
Maximum Moment M_x	8 Nm [340 in-lbs]	6 Nm [56 in-lbs]
Maximum Moment M_y	38 Nm [340 in-lbs]	6 Nm [56 in-lbs]
Maximum Moment M_z	38 Nm [340 in-lbs]	6 Nm [56 in-lbs]

†Capacities are per set of jaws and are not simultaneous

DPDS-175M, 175M-B



2-Jaw General Industrial Grippers | Dimensions and Technical Specifications

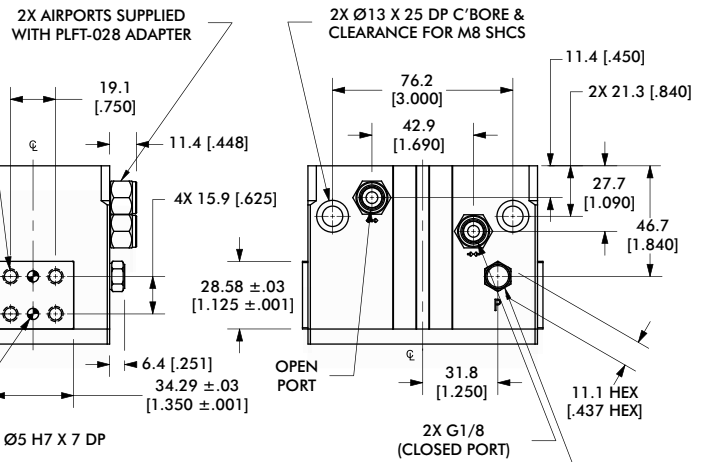
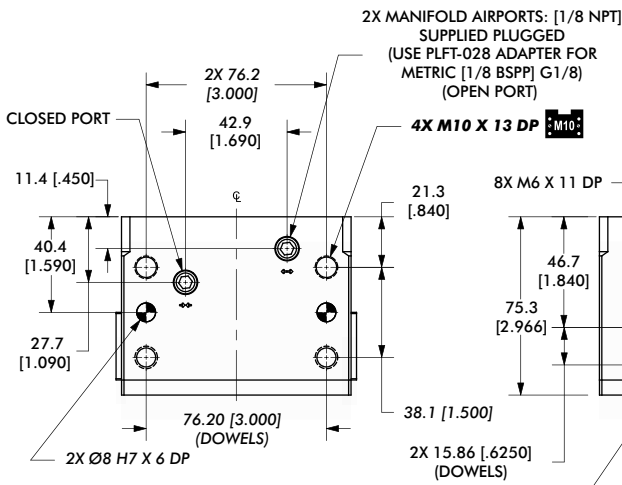
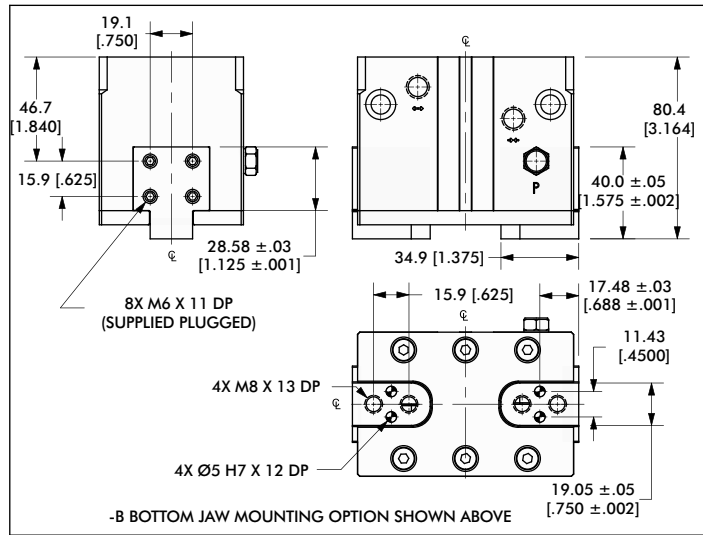
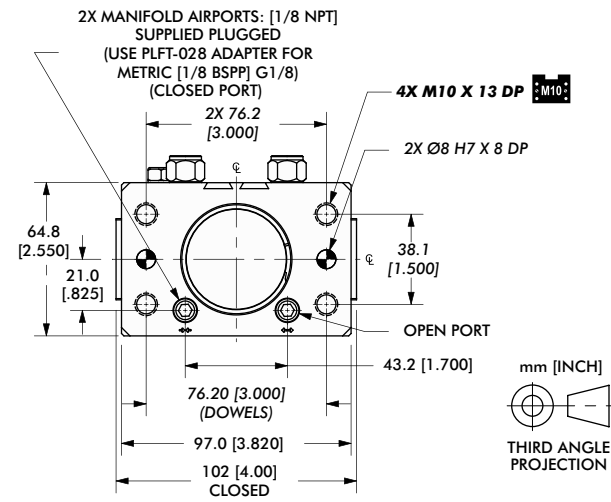

Seal Repair Kits	175M
Buna-N Seal Repair Kit	SLKT-189
Viton® Seal Repair Kit	SLKT-189V
Manifold Seal Kit (Viton® only)	SLKT-201V

Loading Information

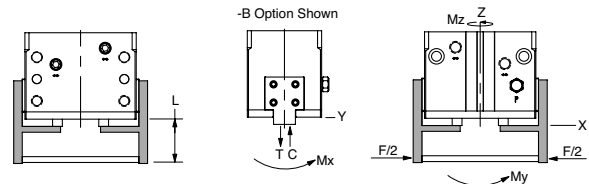
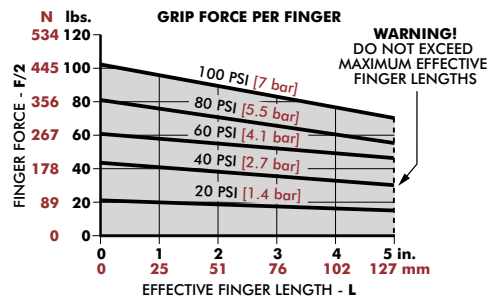

DPDS-175M	Static	Dynamic
Maximum Tensile T	4450 N [1000 lbs]	668 N [150 lbs]
Maximum Compressive C	8900 N [2000 lbs]	668 N [150 lbs]
Maximum Moment M_x	113 Nm [1000 in-lbs]	20 Nm [175 in-lbs]
Maximum Moment M_y	113 Nm [1000 in-lbs]	20 Nm [175 in-lbs]
Maximum Moment M_z	113 Nm [1000 in-lbs]	20 Nm [175 in-lbs]

[†]Capacities are per set of jaws and are not simultaneous

DPDS-175M-B	Static	Dynamic
Maximum Tensile T	3560 N [800 lbs]	534 N [120 lbs]
Maximum Compressive C	7120 N [1600 lbs]	534 N [120 lbs]
Maximum Moment M_x	90 Nm [800 in-lbs]	16 Nm [140 in-lbs]
Maximum Moment M_y	90 Nm [800 in-lbs]	16 Nm [140 in-lbs]
Maximum Moment M_z	90 Nm [800 in-lbs]	16 Nm [140 in-lbs]

[†]Capacities are per set of jaws and are not simultaneous

2-Jaw General Industrial Grippers | Dimensions and Technical Specifications

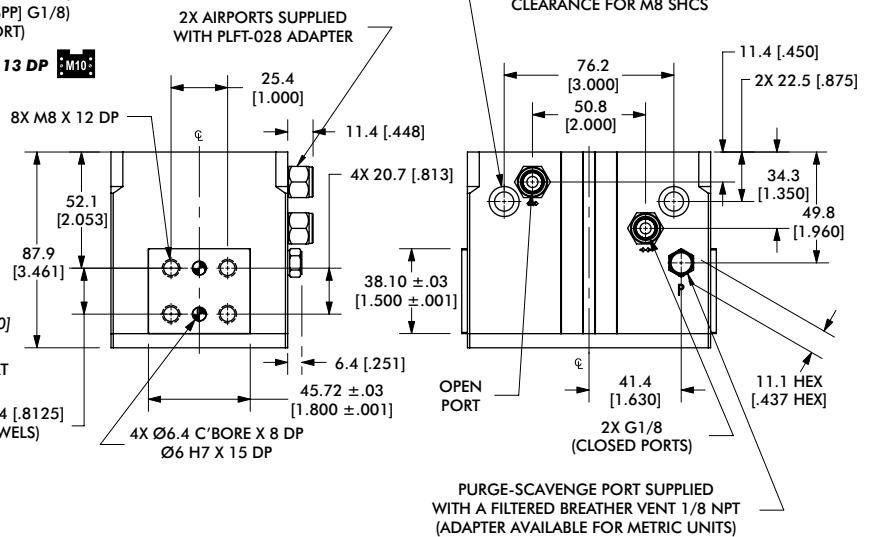
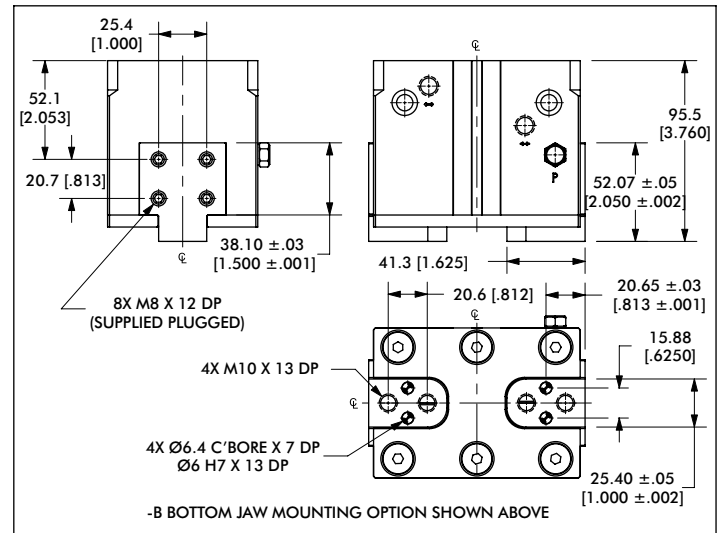
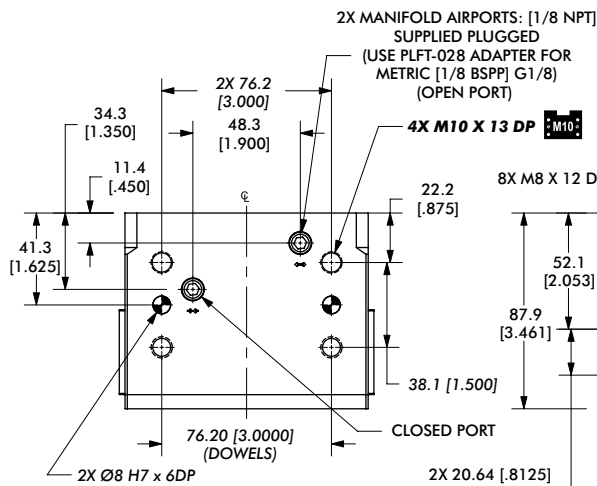
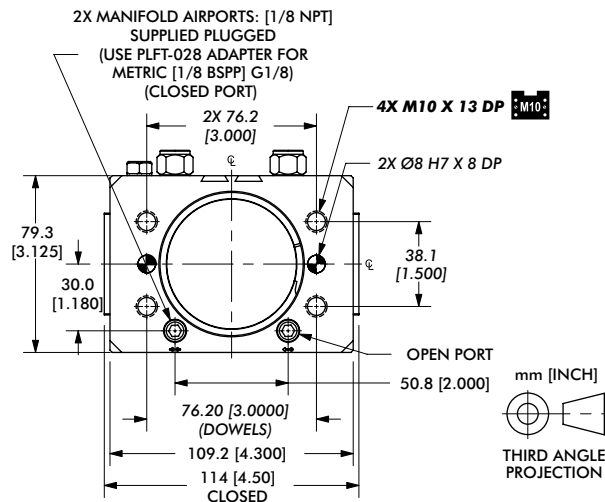

Seal Repair Kits	250M
Buna-N Seal Repair Kit	SLKT-190
Viton® Seal Repair Kit	SLKT-190V
Manifold Seal Kit (Viton® only)	SLKT-201V

Loading Information

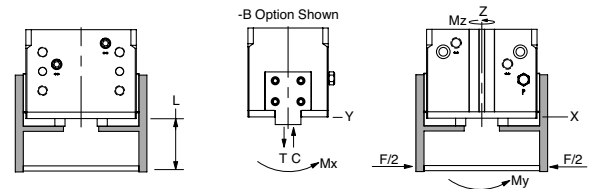
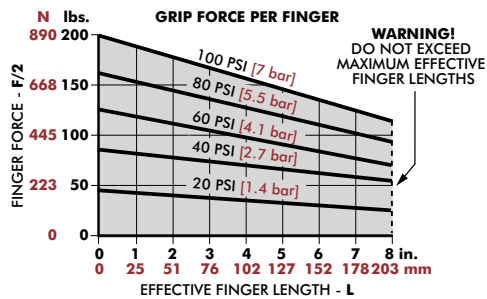

DPDS-250M	Static	Dynamic
Maximum Tensile T	5785 N [1300 lbs]	979 N [220 lbs]
Maximum Compressive C	12015 N [2700 lbs]	979 N [220 lbs]
Maximum Moment M_x	153 Nm [1350 in-lbs]	25 Nm [225 in-lbs]
Maximum Moment M_y	153 Nm [1350 in-lbs]	25 Nm [225 in-lbs]
Maximum Moment M_z	153 Nm [1350 in-lbs]	25 Nm [225 in-lbs]

*Capacities are per set of jaws and are not simultaneous

DPDS-250M-B	Static	Dynamic
Maximum Tensile T	4628 N [1040 lbs]	783 N [176 lbs]
Maximum Compressive C	9612 N [2160 lbs]	783 N [176 lbs]
Maximum Moment M_x	122 Nm [1080 in-lbs]	20 Nm [180 in-lbs]
Maximum Moment M_y	122 Nm [1080 in-lbs]	20 Nm [180 in-lbs]
Maximum Moment M_z	122 Nm [1080 in-lbs]	20 Nm [180 in-lbs]

*Capacities are per set of jaws and are not simultaneous

DPG SERIES

2-Jaw General Industrial Grippers | Features and Benefits | How To Order

Features:

- Rugged general purpose modular gripper
- Multi-position sensing up to 4 locations
- Shielded gripper to repel metal chips and particulates
- Spring assist option maintains grip in case of air pressure loss
- Synchronous or non-synchronous jaw operation
- Multiple air ports support manifold interface using O-rings
- Two finger mounting surfaces on each jaw

Applications:

- CNC Machining applications
- Chip and dry particulate harsh environments
- Non-synchronous jaw or fixed jaw clamp operations

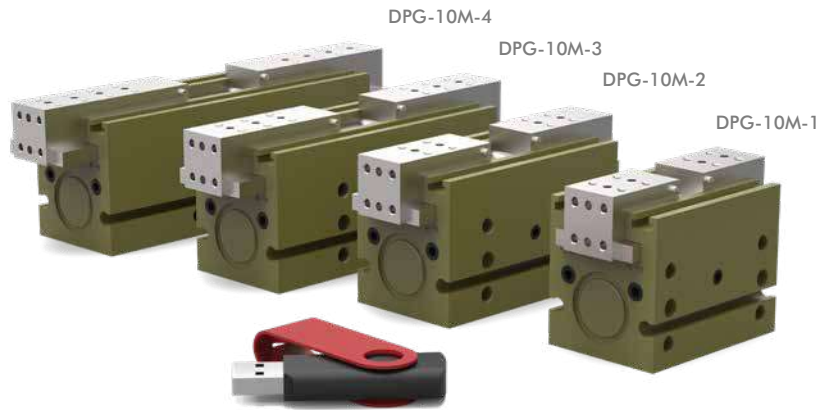

(USB key shown for scale)

How To Order

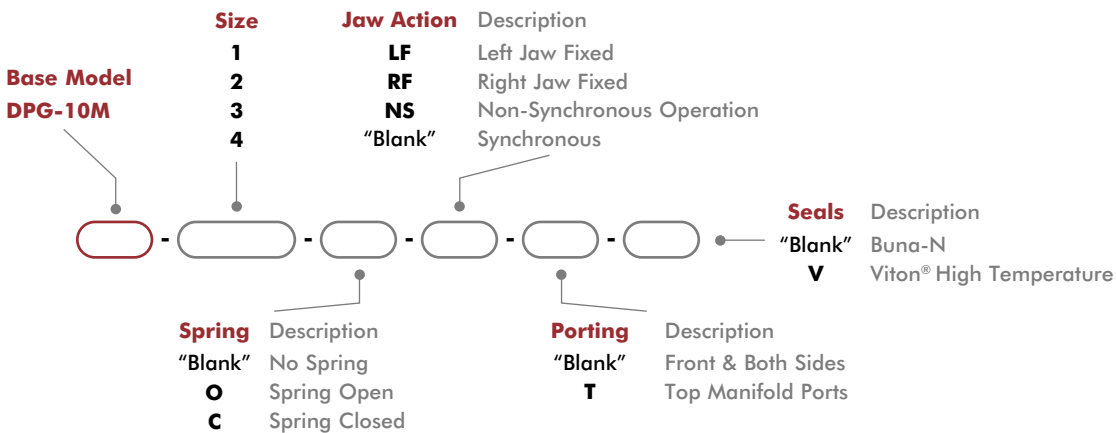

2-Jaw General Industrial Grippers | How To Order, Technical Specifications

Sensor Accessories	Model Numbers	Part Number	Qty/Unit
Inductive Sensor Mounting Kit (Mounts 2 Sensors)	All Models	OSMK-097	1-2
NPN Inductive Sensor with Qk. Disconnect*	All Models	OISN-019	1-4
PNP Inductive Sensor with Qk. Disconnect*	All Models	OISP-019	1-4
NPN Magneto Resistive Sensor w/Qk. Disconnect*	All Models	OHSN-017	1-4
PNP Magneto Resistive Sensor w/Qk. Disconnect*	All Models	OHSP-017	1-4
NPN Magneto Resistive Sensor (90°) w/Qk. Disconnect*	All Models	OHSN-011	1-4
PNP Magneto Resistive Sensor (90°) w/Qk. Disconnect*	All Models	OHSP-011	1-4
Quick Disconnect Cable (2 meters long)*	All Models	CABL-010	1-4
Quick Disconnect Cable (5 meters long)*	All Models	CABL-013	1-4
Quick Disconnect Cable Extension Cord (1 meter long)*	All Models	CABL-015	1-4
Quick Disconnect Cable Extension Cord (2 meters long)*	All Models	CABL-016	1-4

Pneumatic Accessories	Model Numbers	Part Number	Qty/Unit
Buna-N Seal Repair Kit	All Models	SLKT-183	1
Viton® Seal Repair Kit	All Models	SLKT-183V	1
-T Plumbing Fitting - M3 male to 3mm OD Tube Push-in Style	All Models	PLFT-021	1-2
-T Plumbing Fitting - M3 male to 2mm ID Tube Barb Style	All Models	PLFT-022	1-2
Fail Safe Valve - M5 (Metric)	All Models	OFSV-004	1
Adjustable Flow Control (Metric)	All Models	VLVF-008	1-2
Top Port Manifold Seal Kit	All Models	SLKT-184V	1

*Sensor and cable sold separately.

Specifications

Specifications	Units	10M-1	10M-2	10M-3	10M-4
Total Rated Grip Force F @ 100 psi [7 bar]	N [lbs]	222 [50]			
Total Stroke	mm [in]	6.4 [0.25]	12.7 [0.50]	19.1 [0.75]	25.4 [1.00]
Weight	kg [lbs]	0.17 [0.39]	0.24 [0.53]	0.68 [0.30]	0.81 [0.36]
Pressure Range (without spring)	bar [psi]	3-7 [40-100]			
Pressure Range (with spring)	bar [psi]	1.4-7 [20-100]		3.4-7 [50-100]	
Ingress Protection Class (IP)		IP54			
Displacement	cm ³ [in ³]	1.2 [0.076]	2.5 [0.153]	3.8 [0.230]	5.0 [0.306]
Temperature Range (Buna-N seals)	°C [°F]	-35°~80° [-30°~180°]			
Temperature Range (Viton® seals)	°C [°F]	-30°~150° [-20°~300°]			
Actuation	sec	0.13	0.19	0.29	0.40
Accuracy	mm [in]	±0.05 [±0.002]			
Repeatability	mm [in]	±0.05 [±0.002]			
Valve to Actuate Double Acting		4-way, 2-position			

2-Jaw General Industrial Grippers | Dimensions and Technical Specifications

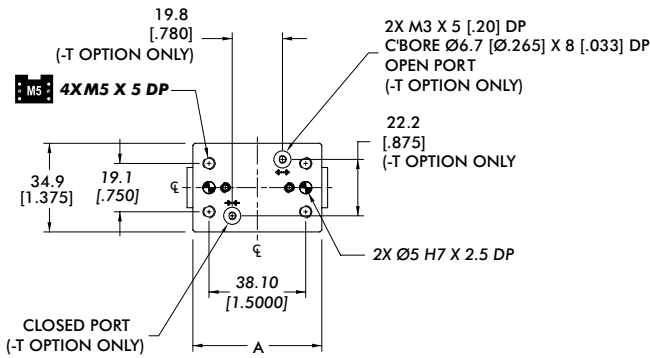

Model	A	B	C	D
DPG-10M-1	50.8 [2.000]	62.0 [2.44]	55.6 [2.19]	29.2 [1.15]
DPG-10M-2	68.3 [2.688]	85.6 [3.37]	72.9 [2.87]	36.8 [1.45]
DPG-10M-3	88.9 [3.500]	112.8 [4.44]	93.7 [3.69]	55.9 [2.20]
DPG-10M-4	106.4 [4.188]	136.7 [5.38]	111.3 [4.38]	61.7 [2.43]

Dimensions in mm [in]

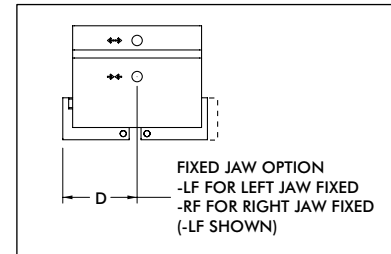
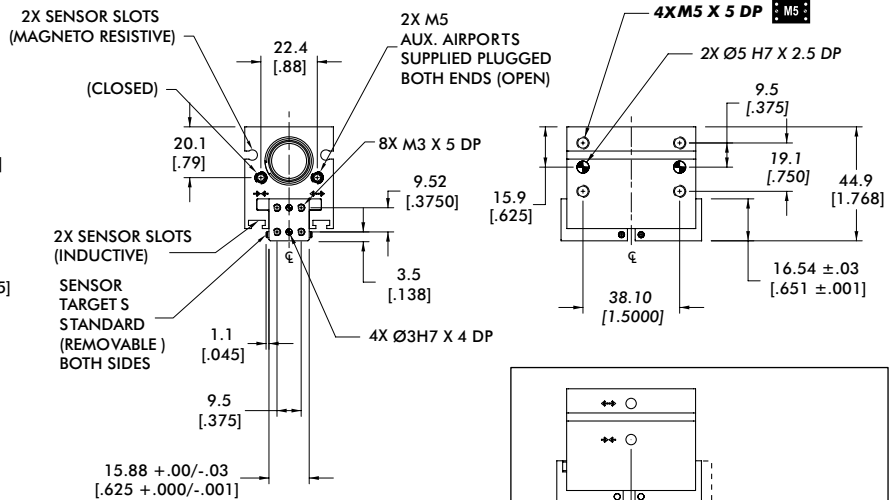
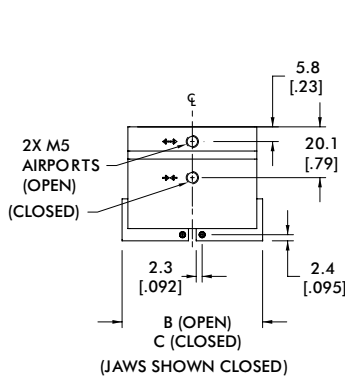

mm [INCH]
THIRD ANGLE PROJECTION

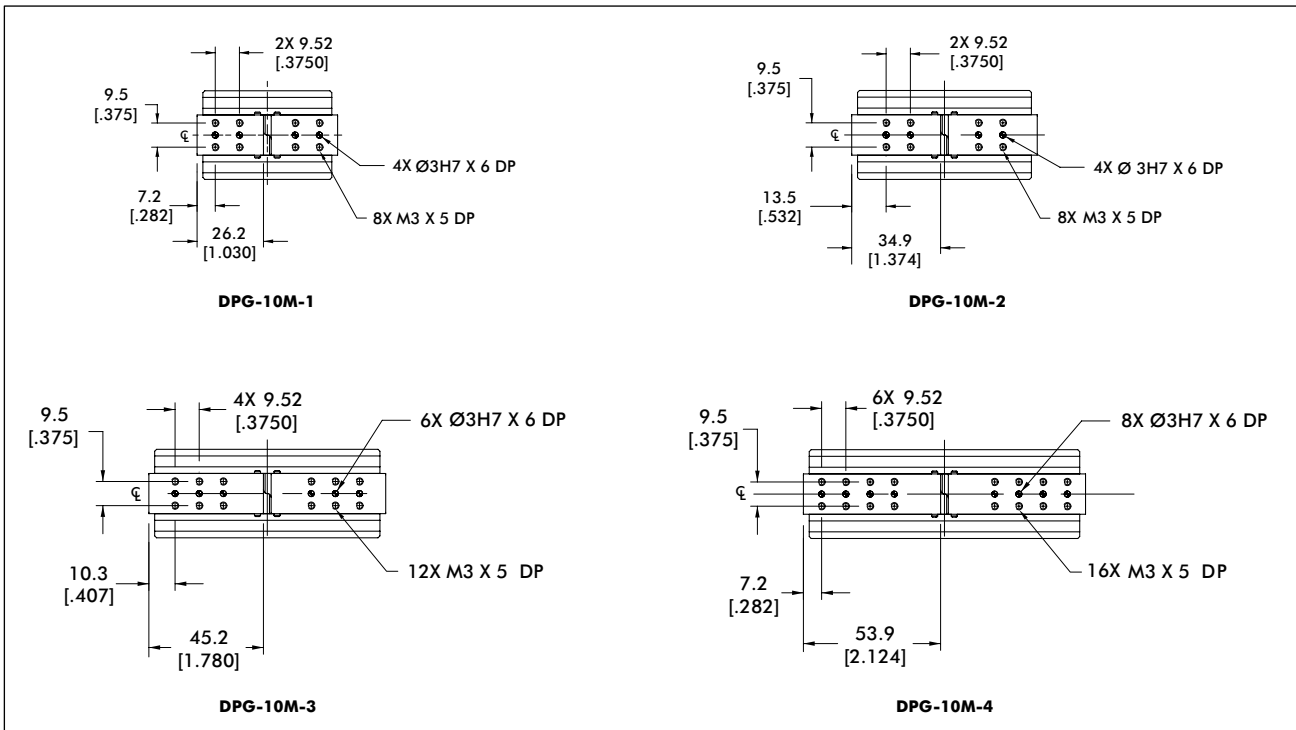

2-Jaw General Industrial Grippers | Loading Capacity

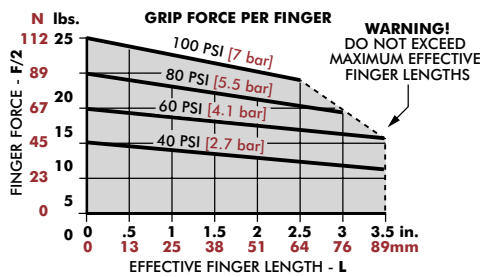

Total Additional Grip Force	Spring Open	Spring Close
@ Full Open	26 N [6 lbs]	40 N [9 lbs]
@ Full Close	49 N [11 lbs]	26 N [6 lbs]

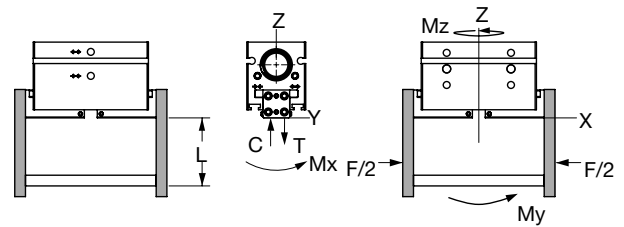

DPG-10M-1	Static	Dynamic
Maximum Tensile T	778 N [175 lbs]	89 N [20 lbs]
Maximum Compressive C	1779 N [400 lbs]	89 N [20 lbs]
Maximum Moment M_x	17 Nm [150 in-lbs]	2 Nm [20 in-lbs]
Maximum Moment M_y	20 Nm [175 in-lbs]	3 Nm [30 in-lbs]
Maximum Moment M_z	17 Nm [150 in-lbs]	2 Nm [20 in-lbs]

*Capacities are per set of jaws and are not simultaneous

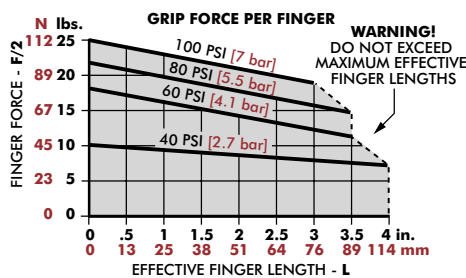

Total Additional Grip Force	Spring Open	Spring Close
@ Full Open	26 N [6 lbs]	62 N [14 lbs]
@ Full Close	66 N [15 lbs]	26 N [6 lbs]

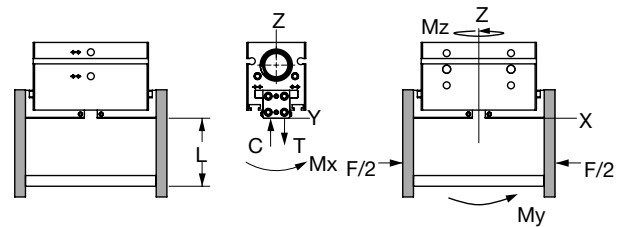

DPG-10M-2	Static	Dynamic
Maximum Tensile T	890 N [200 lbs]	111 N [25 lbs]
Maximum Compressive C	1890 N [425 lbs]	111 N [25 lbs]
Maximum Moment M_x	20 Nm [175 in-lbs]	3 Nm [25 in-lbs]
Maximum Moment M_y	23 Nm [200 in-lbs]	4 Nm [35 in-lbs]
Maximum Moment M_z	20 Nm [175 in-lbs]	3 Nm [25 in-lbs]

*Capacities are per set of jaws and are not simultaneous

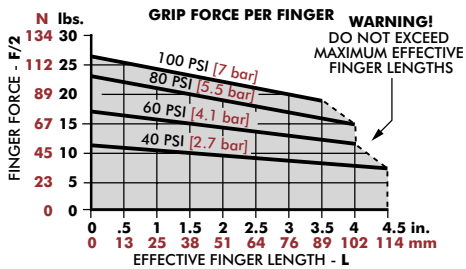

Total Additional Grip Force	Spring Open	Spring Close
@ Full Open	26 N [6 lbs]	66 N [15 lbs]
@ Full Close	102 N [23 lbs]	26 N [6 lbs]

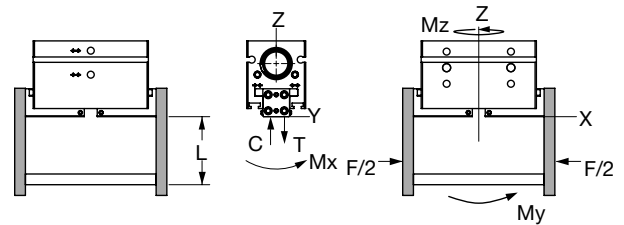

DPG-10M-3	Static	Dynamic
Maximum Tensile T	1001 N [225 lbs]	133 N [30 lbs]
Maximum Compressive C	2002 N [450 lbs]	133 N [30 lbs]
Maximum Moment M_x	23 Nm [200 in-lbs]	3 Nm [30 in-lbs]
Maximum Moment M_y	25 Nm [225 in-lbs]	5 Nm [40 in-lbs]
Maximum Moment M_z	23 Nm [200 in-lbs]	3 Nm [30 in-lbs]

*Capacities are per set of jaws and are not simultaneous

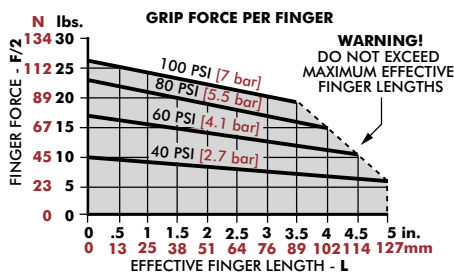

Total Additional Grip Force	Spring Open	Spring Close
@ Full Open	26 N [6 lbs]	66 N [15 lbs]
@ Full Close	97 N [22 lbs]	26 N [6 lbs]

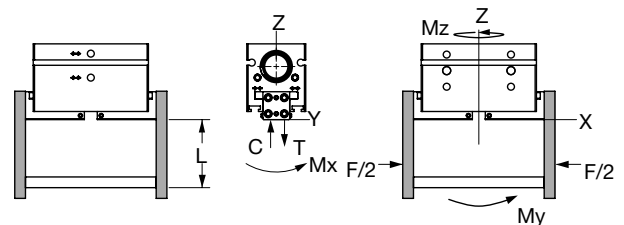

DPG-10M-4	Static	Dynamic
Maximum Tensile T	1112 N [250 lbs]	156 N [35 lbs]
Maximum Compressive C	2113 N [475 lbs]	156 N [35 lbs]
Maximum Moment M_x	25 Nm [225 in-lbs]	4 Nm [35 in-lbs]
Maximum Moment M_y	28 Nm [250 in-lbs]	5 Nm [45 in-lbs]
Maximum Moment M_z	25 Nm [225 in-lbs]	4 Nm [35 in-lbs]

*Capacities are per set of jaws and are not simultaneous

RDH SERIES

2-Jaw General Industrial Grippers | Features and Benefits | How To Order

Features:

- Rugged multi-purpose powerful gripper
- 8 sizes for small lightweight to very large and heavy part gripping
- High impact resistant with double wedge design
- Shielded gripper to repel metal chips and particulates
- Spring assist option maintains grip in case of air pressure loss
- Purge and scavenge ports for harsh & clean environments
- Multi-position sensing up to 4 locations

Applications:

- High particulate application environments
- Automotive engine block and gantry systems
- Ideal for very heavy part gripping

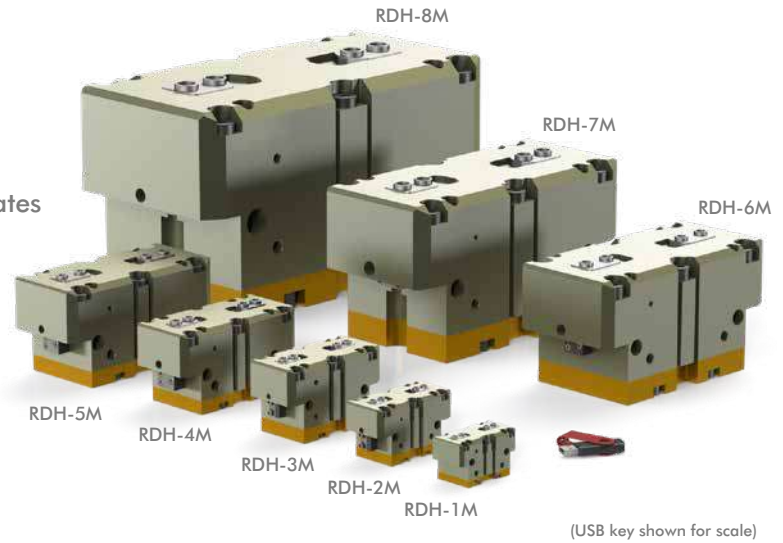

How To Order

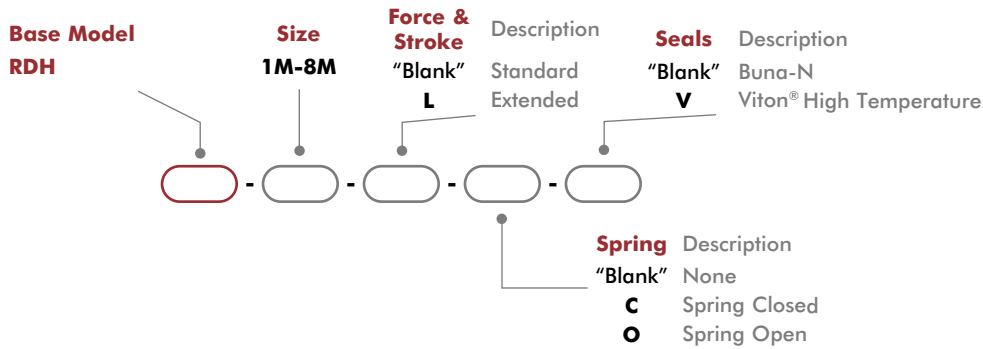

Accessories

Sensor Accessories	Model Numbers	Part Number	Qty/Unit
8mm PNP Magneto Resistive Sensor (90° barrel) w/ M8 Qk. Disc*	All Models	OHSP-011	1-4
8mm NPN Magneto Resistive Sensor (90° barrel) w/ M8 Qk. Disc*	All Models	OHSN-011	1-4
8mm PNP Magneto Resistive Sensor Short Barrel w/ M8 Qk Disc*	All Models	OHSP-017	1-4
8mm NPN Magneto Resistive Sensor Short Barrel w/ M8 Qk Disc*	All Models	OHSN-017	1-4
8mm PNP Inductive Sensor w/ M8 Quick Disconnect*	RDH-4M, -5M, -6M	OISP-011	1-2
8mm NPN Inductive Sensor w/ M8 Quick Disconnect*	RDH-4M, -5M, -6M	OISN-011	1-2
12mm PNP Inductive Sensor w/ M12 Quick Disconnect*	RDH-7M, -8M	OISP-017	1-2
12mm NPN Inductive Sensor w/ M12 Quick Disconnect*	RDH-7M, -8M	OISN-017	1-2
M8 Quick Disconnect 2 Meter Cable Length*	All Models	CABL-010	1-4
M8 Quick Disconnect 5 Meter Cable Length*	All Models	CABL-013	1-4
M12 Quick Disconnect 2 Meter Cable Length*	RDH-7M, -8M	CABL-014	1-2
M12 Quick Disconnect 5 Meter Cable Length*	RDH-7M, -8M	CABL-018	1-2

Pneumatic Accessories	Model Numbers	Part Number	Qty/Unit
M5 Adjustable Flow Control	RDH-1M, -2M, -3M	VLVF-008	1-2
G 1/4" Adjustable Flow Control	RDH-4M, -5M, -6M, -7M	VLVF-005	1-2
G 1/8" Adjustable Flow Control	RDH-8M	VLVF-010	1-2

* Sensor and cable sold separately.

2-Jaw General Industrial Grippers | Technical Specifications

Specifications	Units	1M	1M-L	2M	2M-L	3M	3M-L	4M	4M-L
Total Rated Grip Force F @ 100 psi [7 bar] w/o Spring Assist	N [lbs]	555 [125]	361 [81]	754 [170]	494 [111]	1317 [296]	854 [192]	2177 [490]	1414 [318]
Total Rated Grip Force F @ 100 psi [7 bar] with Spring Assist	N [lbs]	693 [156]	452 [102]	1006 [226]	661 [149]	1683 [379]	1094 [246]	2789 [628]	1814 [408]
Total Stroke	mm [in]	4 [0.16]	8 [0.32]	6 [0.24]	12 [0.47]	8 [0.31]	16 [0.63]	10 [0.39]	20 [0.79]
Weight	kg [lbs]	0.19 [0.4]	0.21 [0.5]	0.39 [0.86]	0.42 [0.93]	0.82 [1.81]	0.88 [1.94]	1.43 [3.15]	1.51 [3.33]
Pressure Range w/o Spring	bar [psi]	2-7 [30-100]							
Pressure Range with Spring	bar [psi]	3.5-7 [50-100]							
Max. Vacuum for Scavenge Port	mm Hg [in Hg]	200 [8]							
Max. Pressure for Purge Port	bar [psi]	2.1 [30]							
Ingress Protection Class (IP)		IP55							
Displacement	cm ³ [in ³]	5 [0.31]		10.3 [0.63]		23.4 [1.43]		47.5 [2.90]	
Temperature Range (Buna-N seals)	°C [°F]	-35°~80° [-30°~180°]							
Temperature Range (Viton® seals)	°C [°F]	-30°~150° [-20°~300°]							
Actuation (open/close)	sec.	0.06		0.07				0.08	
Accuracy	mm [in]			±0.04 [±0.002]					±0.06 [±0.0024]
Repeatability	mm [in]			±0.02 [±0.001]					±0.03 [±0.0012]
Valve to Actuate Single Acting		3-way, 2-position							
Valve to Actuate Double Acting		4-way, 2-position							

Specifications (cont.)	Units	5M	5M-L	6M	6M-L	7M	7M-L	8M	8M-L
Total Rated Grip Force F @ 100 psi [7 bar] w/o Spring Assist	N [lbs]	3593 [808]	2333 [525]	6250 [1406]	4062 [914]	9901 [2228]	6404 [1441]	21958 [4941]	14178 [3190]
Total Rated Grip Force F @ 100 psi [7 bar] with Spring Assist	N [lbs]	4609 [1037]	2999 [675]	8640 [1944]	5623 [1265]	12542 [2822]	8135 [1830]	28002 [6300]	18115 [4076]
Total Stroke	mm [in]	13 [0.51]	26 [1.02]	16 [0.63]	32 [1.26]	25 [0.98]	50 [1.97]	35 [1.38]	70 [2.76]
Weight	kg [lbs]	2.75 [6.06]	2.98 [6.57]	5.77 [12.72]		11.25 [24.8]		32.3 [71.1]	
Pressure Range w/o Spring	bar [psi]	2-7 [30-100]							
Pressure Range with Spring	bar [psi]	4-7 [60-100]		4.5-7 [65-100]		4-7 [60-100]		3.5-7 [50-100]	
Max. Vacuum for Scavenge Port	mm Hg [in Hg]	20 [8]							
Max. Pressure for Purge Port	bar [psi]	2.1 [30]							
Ingress Protection Class (IP)		IP55							
Displacement	cm ³ [in ³]	102 [6.22]		216 [13.18]		540 [32.95]		1689 [103.1]	
Temperature Range (Buna-N seals)	°C [°F]	-35°~80° [-30°~180°]							
Temperature Range (Viton® seals)	°C [°F]	-30°~150° [-20°~300°]							
Actuation (open/close)	sec.	0.14		0.20		0.55		1.3	
Accuracy	mm [in]	±0.06 [±0.0024]		±0.08 [±0.0031]				±0.1 [±0.0039]	
Repeatability	mm [in]	±0.03 [±0.0012]		±0.04 [±0.0016]				±0.05 [±0.002]	
Valve to Actuate Single Acting		3-way, 2-position							
Valve to Actuate Double Acting		4-way, 2-position							

RDH-1M, -1M-L

2-Jaw General Industrial Grippers | Dimensions and Technical Specifications

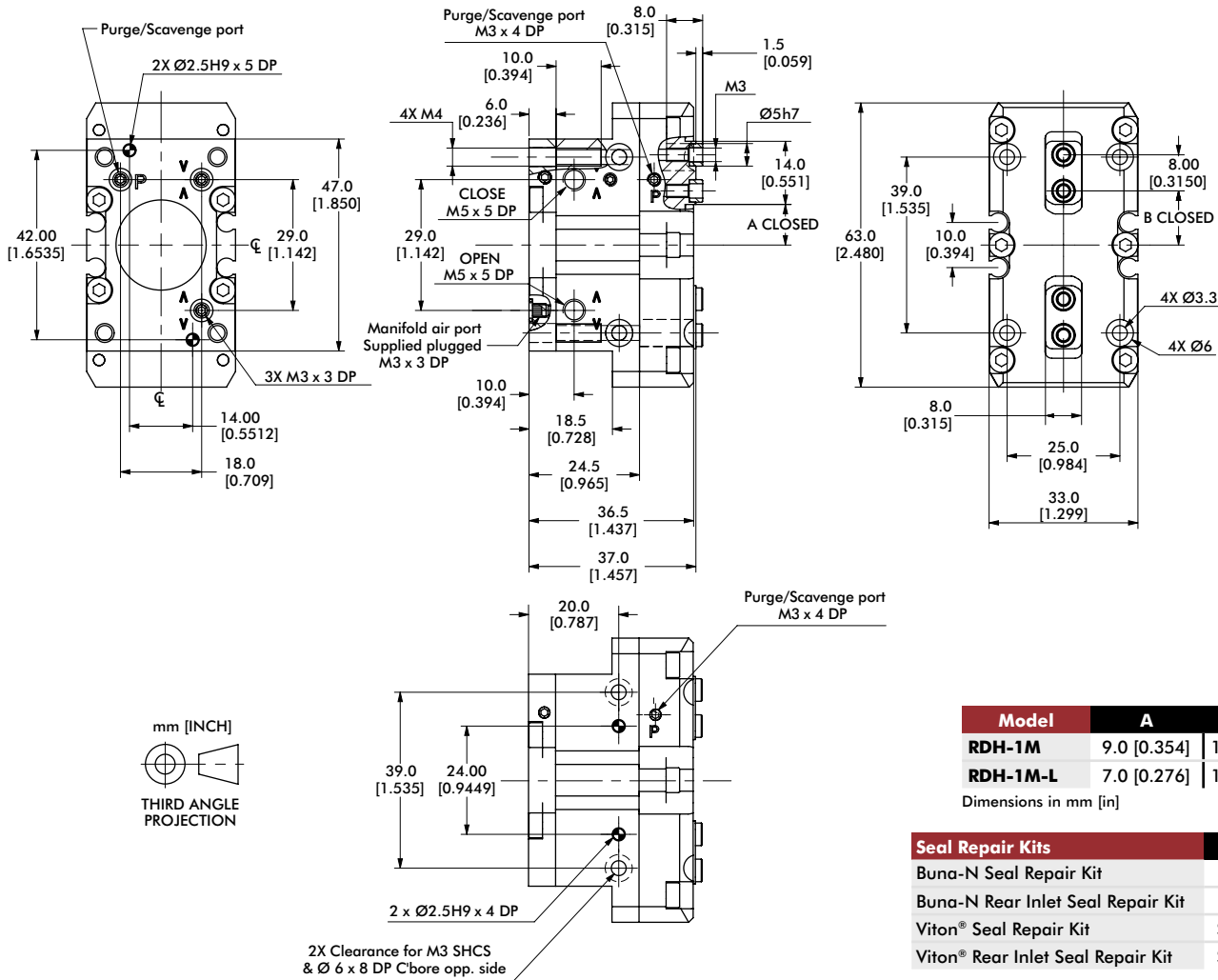

Loading Information

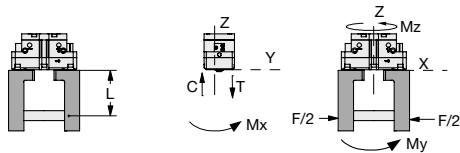
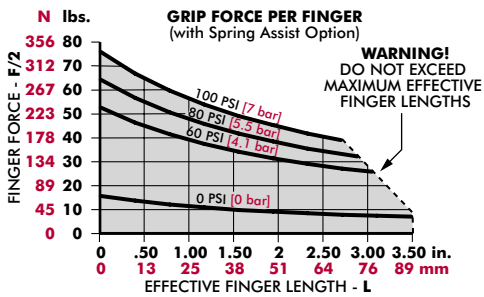

RDH-1M	Static	Dynamic
Maximum Tensile T	594 N [134 lbs]	74 N [17 lbs]
Maximum Compressive C	779 N [175 lbs]	74 N [17 lbs]
Maximum Moment M_x	18 Nm [159 in-lbs]	2 Nm [18 in-lbs]
Maximum Moment M_y	23 Nm [204 in-lbs]	2 Nm [18 in-lbs]
Maximum Moment M_z	14 Nm [124 in-lbs]	2 Nm [18 in-lbs]

*Capacities are per set of jaws and are not simultaneous

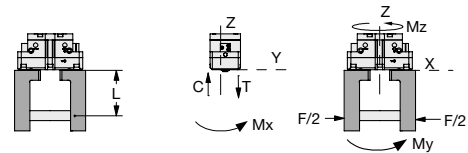
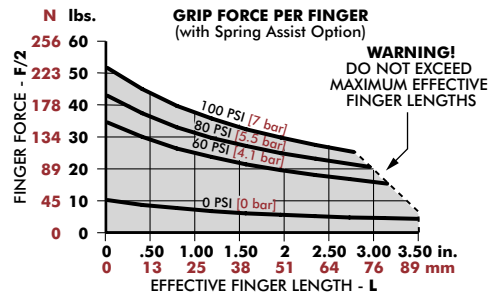

RDH-1M-L	Static	Dynamic
Maximum Tensile T	540 N [121 lbs]	48 N [11 lbs]
Maximum Compressive C	708 N [159 lbs]	48 N [11 lbs]
Maximum Moment M_x	16 Nm [142 in-lbs]	1 Nm [9 in-lbs]
Maximum Moment M_y	19 Nm [168 in-lbs]	1 Nm [9 in-lbs]
Maximum Moment M_z	12 Nm [106 in-lbs]	1 Nm [9 in-lbs]

*Capacities are per set of jaws and are not simultaneous

RDH-2M, -2M-L

2-Jaw General Industrial Grippers | Dimensions and Technical Specifications

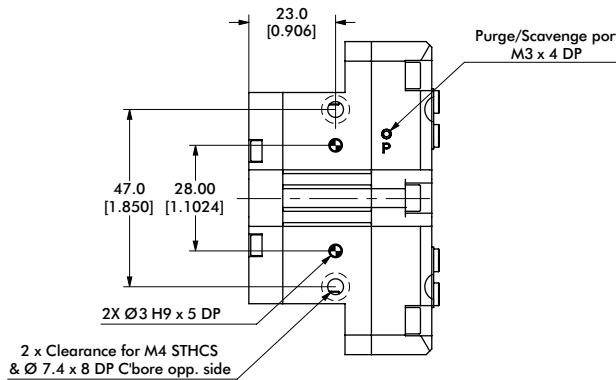
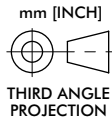
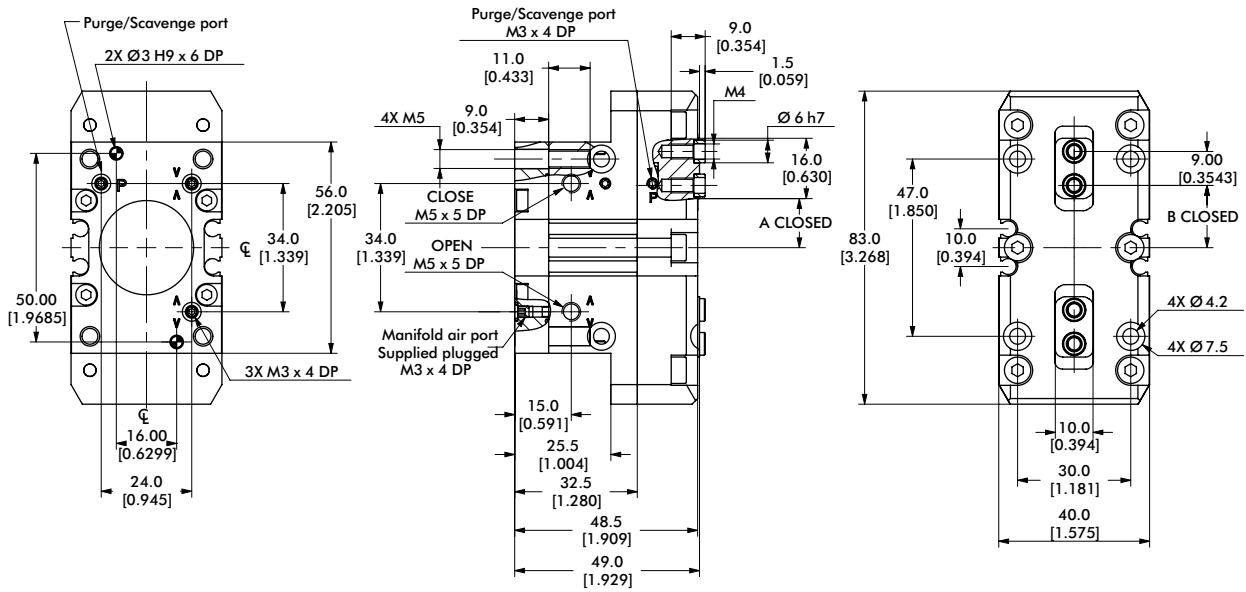

Model	A	B
RDH-2M	13.0 [0.512]	16.5 [0.650]
RDH-2M-L	10.0 [0.394]	13.5 [0.531]

Dimensions in mm [in]

Seal Repair Kits	RDH-2M
Buna-N Seal Repair Kit	SLKT-417
Buna-N Rear Inlet Seal Repair Kit	SLKT-363
Viton® Seal Repair Kit	SLKT-417V
Viton® Rear Inlet Seal Repair Kit	SLKT-363V

Loading Information

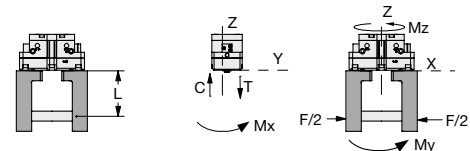
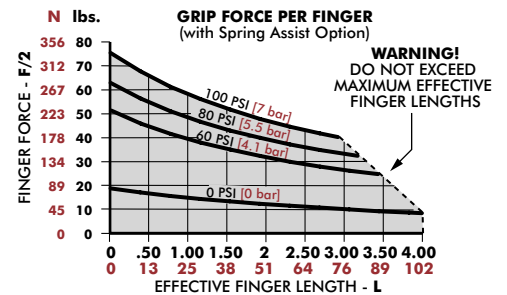
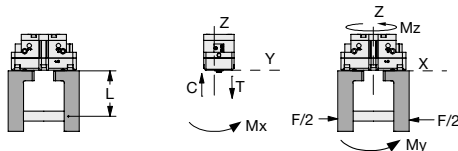
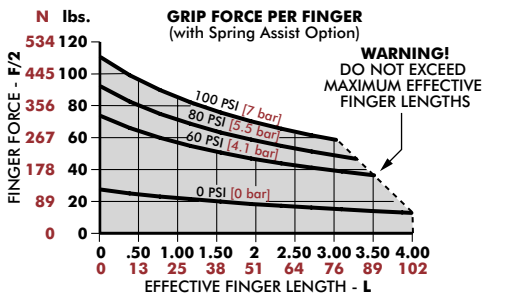

RDH-2M	Static	Dynamic
Maximum Tensile T	849 N [191 lbs]	81 N [18 lbs]
Maximum Compressive C	1103 N [248 lbs]	81 N [18 lbs]
Maximum Moment M_x	36 Nm [319 in-lbs]	3 Nm [27 in-lbs]
Maximum Moment M_y	51 Nm [451 in-lbs]	4 Nm [35 in-lbs]
Maximum Moment M_z	32 Nm [283 in-lbs]	4 Nm [35 in-lbs]

¹Capacities are per set of jaws and are not simultaneous

RDH-2M-L	Static	Dynamic
Maximum Tensile T	764 N [172 lbs]	53 N [12 lbs]
Maximum Compressive C	993 N [223 lbs]	53 N [12 lbs]
Maximum Moment M_x	32 Nm [283 in-lbs]	2 Nm [18 in-lbs]
Maximum Moment M_y	41 Nm [363 in-lbs]	2 Nm [18 in-lbs]
Maximum Moment M_z	26 Nm [230 in-lbs]	2 Nm [18 in-lbs]

¹Capacities are per set of jaws and are not simultaneous

RDH-3M, -3M-L

2-Jaw General Industrial Grippers | Dimensions and Technical Specifications

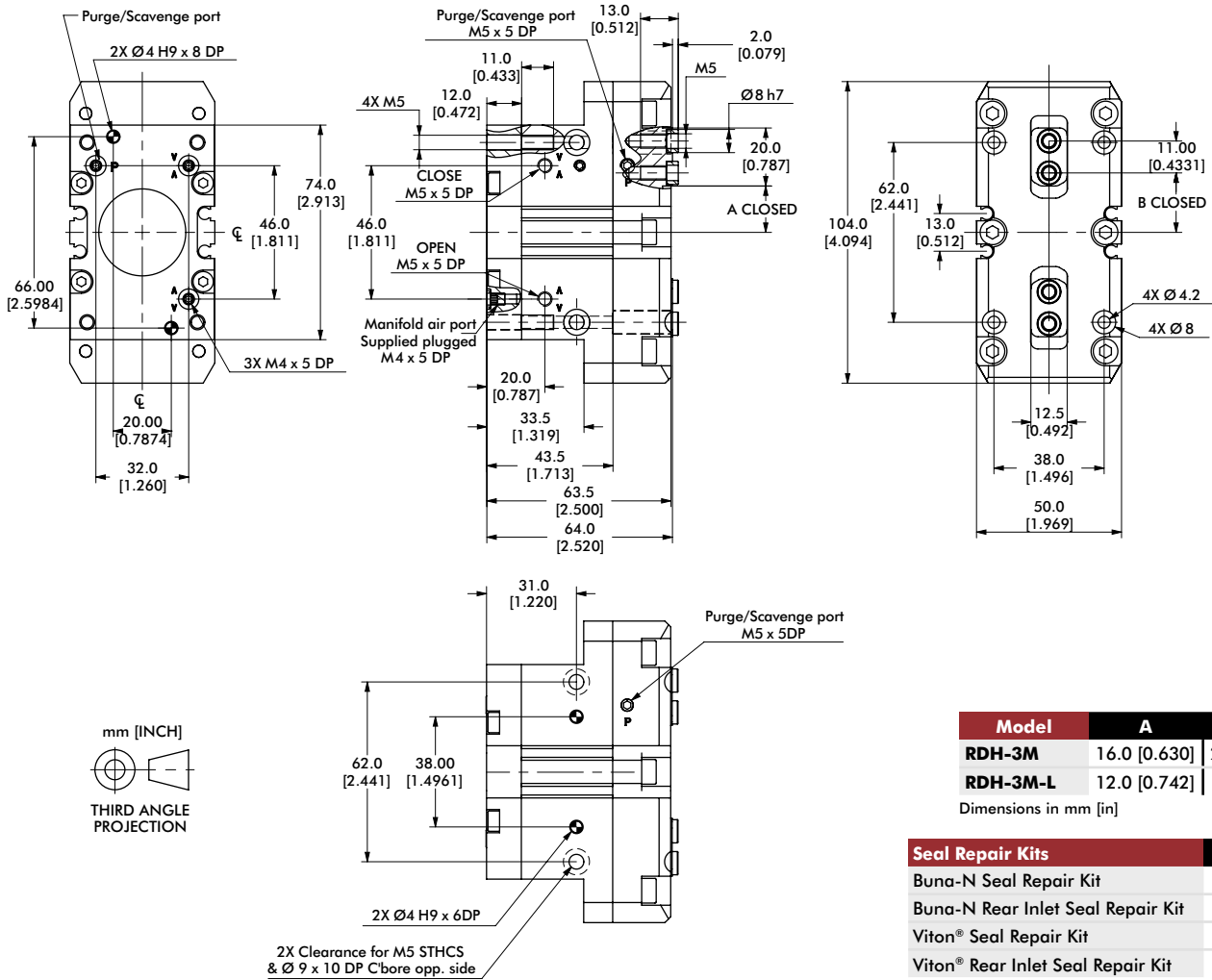

Loading Information

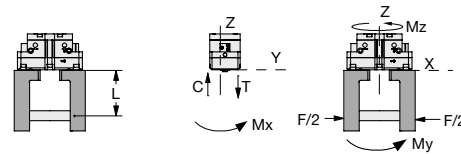
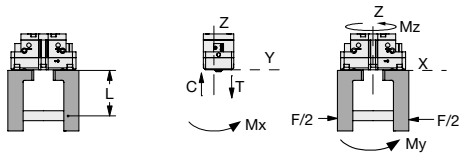
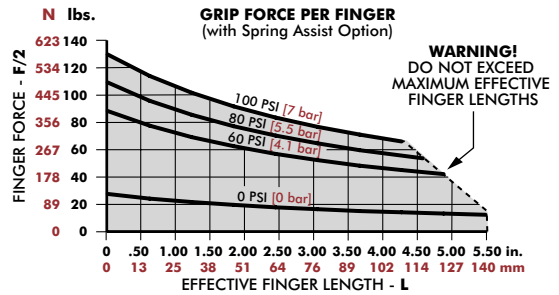
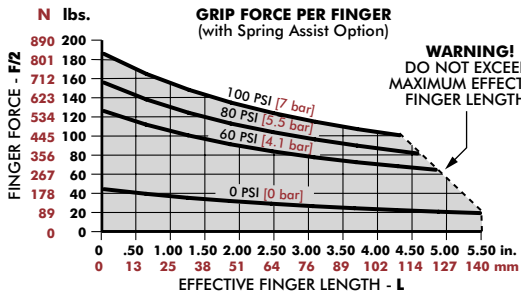

RDH-3M	Static	Dynamic
Maximum Tensile T	1284 N [289 lbs]	196 N [44 lbs]
Maximum Compressive C	1665 N [374 lbs]	196 N [44 lbs]
Maximum Moment M_x	58 Nm [513 in-lbs]	7 Nm [62 in-lbs]
Maximum Moment M_y	83 Nm [735 in-lbs]	11 Nm [97 in-lbs]
Maximum Moment M_z	54 Nm [478 in-lbs]	11 Nm [97 in-lbs]

[†]Capacities are per set of jaws and are not simultaneous

RDH-3M-L	Static	Dynamic
Maximum Tensile T	1146 N [258 lbs]	127 N [29 lbs]
Maximum Compressive C	1485 N [334 lbs]	127 N [29 lbs]
Maximum Moment M_x	52 Nm [460 in-lbs]	5 Nm [44 in-lbs]
Maximum Moment M_y	66 Nm [584 in-lbs]	6 Nm [53 in-lbs]
Maximum Moment M_z	43 Nm [381 in-lbs]	[53 in-lbs] 6 Nm

[†]Capacities are per set of jaws and are not simultaneous

RDH-4M, -4M-L

2-Jaw General Industrial Grippers | Dimensions and Technical Specifications

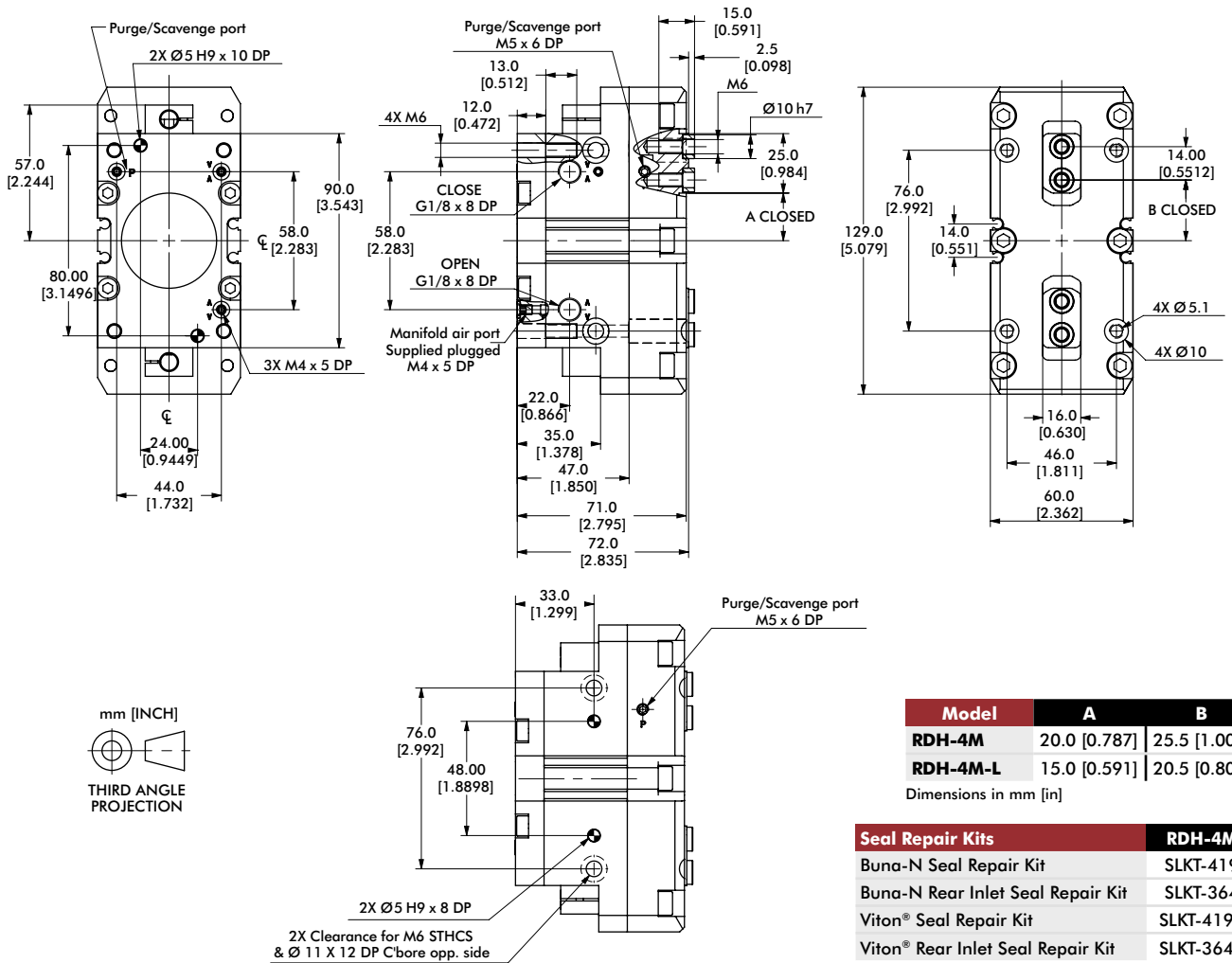

Loading Information

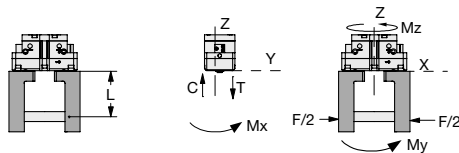
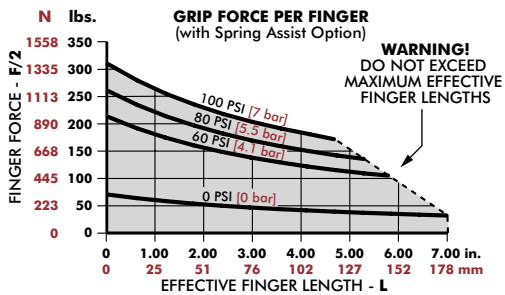

RDH-4M	Static	Dynamic
Maximum Tensile T	1564 N [352 lbs]	259 N [58 lbs]
Maximum Compressive C	2070 N [465 lbs]	259 N [58 lbs]
Maximum Moment M_x	76 Nm [673 in-lbs]	10 Nm [89 in-lbs]
Maximum Moment M_y	106 Nm [938 in-lbs]	14 Nm [124 in-lbs]
Maximum Moment M_z	70 Nm [620 in-lbs]	14 Nm [124 in-lbs]

¹Capacities are per set of jaws and are not simultaneous

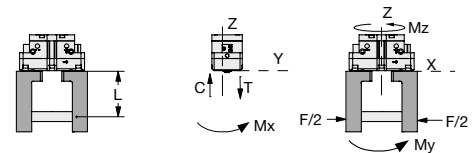
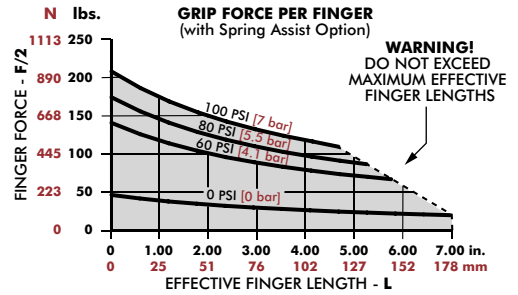

RDH-4M-L	Static	Dynamic
Maximum Tensile T	1394 N [313 lbs]	168 N [38 lbs]
Maximum Compressive C	1845 N [415 lbs]	168 N [38 lbs]
Maximum Moment M_x	68 Nm [602 in-lbs]	6 Nm [53 in-lbs]
Maximum Moment M_y	84 Nm [743 in-lbs]	8 Nm [71 in-lbs]
Maximum Moment M_z	56 Nm [496 in-lbs]	8 Nm [71 in-lbs]

¹Capacities are per set of jaws and are not simultaneous

RDH-5M, -5M-L

2-Jaw General Industrial Grippers | Dimensions and Technical Specifications

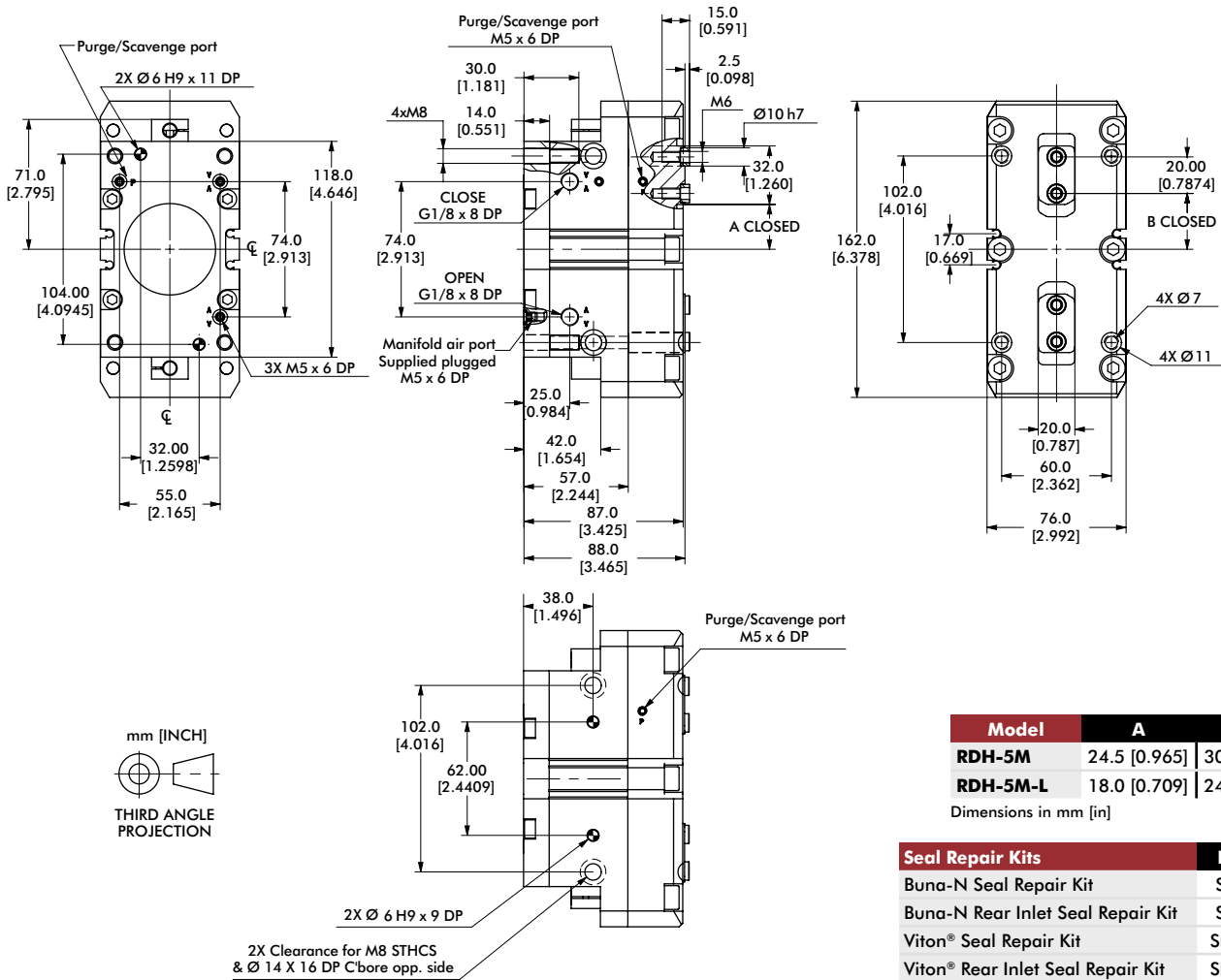

Loading Information

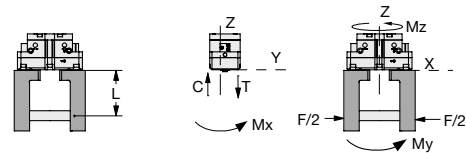
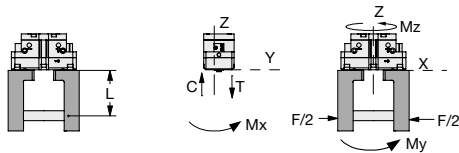
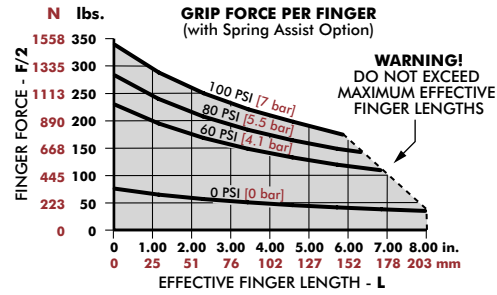
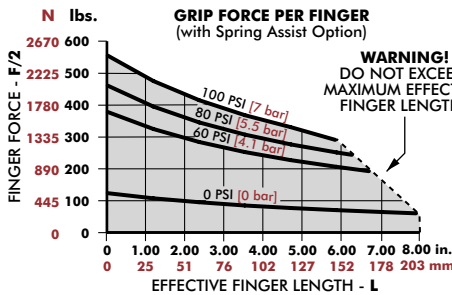

RDH-5M	Static	Dynamic
Maximum Tensile T	2192 N [493 lbs]	428 N [96 lbs]
Maximum Compressive C	2923 N [657 lbs]	428 N [96 lbs]
Maximum Moment M_x	105 Nm [929 in-lbs]	16 Nm [142 in-lbs]
Maximum Moment M_y	148 Nm [1310 in-lbs]	22 Nm [195 in-lbs]
Maximum Moment M_z	97 Nm [859 in-lbs]	22 Nm [195 in-lbs]

RDH-5M-L	Static	Dynamic
Maximum Tensile T	1966 N [442 lbs]	278 N [62 lbs]
Maximum Compressive C	2621 N [589 lbs]	278 N [62 lbs]
Maximum Moment M_x	94 Nm [832 in-lbs]	10 Nm [89 in-lbs]
Maximum Moment M_y	119 Nm [1053 in-lbs]	13 Nm [115 in-lbs]
Maximum Moment M_z	78 Nm [690 in-lbs]	13 Nm [115 in-lbs]

*Capacities are per set of jaws and are not simultaneous

*Capacities are per set of jaws and are not simultaneous

RDH-6M, -6M-L

2-Jaw General Industrial Grippers | Dimensions and Technical Specifications

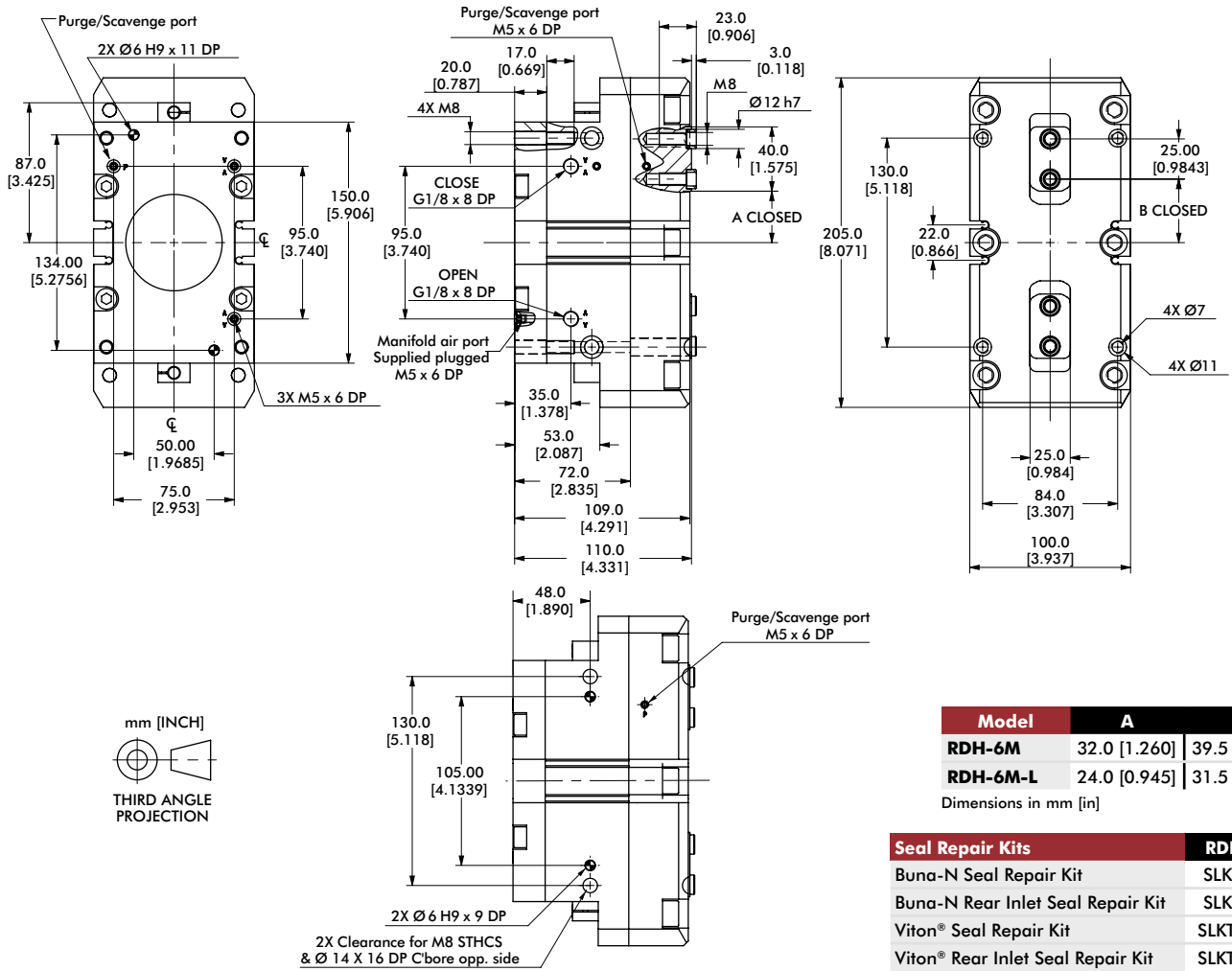

Loading Information

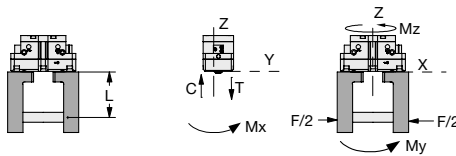
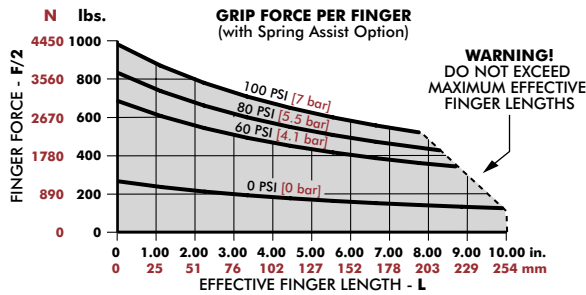

RDH-6M	Static	Dynamic
Maximum Tensile T	3463 N [779 lbs]	827 N [186 lbs]
Maximum Compressive C	4649 N [1045 lbs]	827 N [186 lbs]
Maximum Moment M_x	136 Nm [1204 in-lbs]	28 Nm [248 in-lbs]
Maximum Moment M_y	197 Nm [1744 in-lbs]	41 Nm [363 in-lbs]
Maximum Moment M_z	130 Nm [1151 in-lbs]	41 Nm [363 in-lbs]

†Capacities are per set of jaws and are not simultaneous

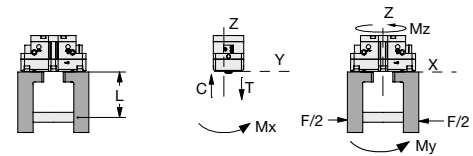
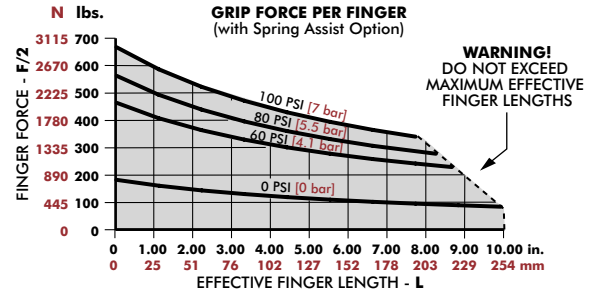

RDH-6M-L	Static	Dynamic
Maximum Tensile T	3089 N [694 lbs]	537 N [121 lbs]
Maximum Compressive C	4146 N [932 lbs]	537 N [121 lbs]
Maximum Moment M_x	121 Nm [1071 in-lbs]	18 Nm [159 in-lbs]
Maximum Moment M_y	157 Nm [1390 in-lbs]	24 Nm [212 in-lbs]
Maximum Moment M_z	103 Nm [912 in-lbs]	24 Nm [212 in-lbs]

†Capacities are per set of jaws and are not simultaneous

RDH-7M, -7M-L

2-Jaw General Industrial Grippers | Dimensions and Technical Specifications

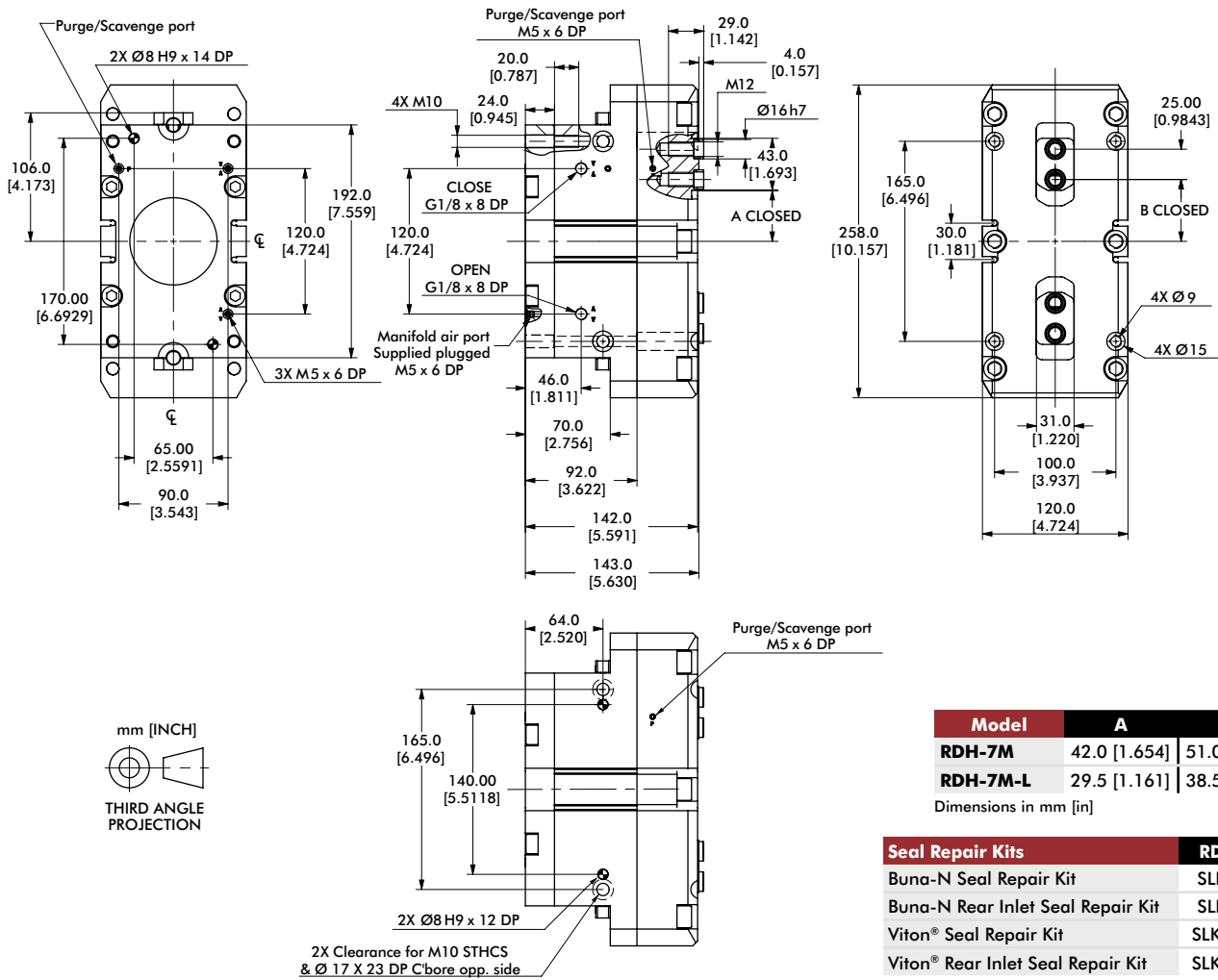

Loading Information

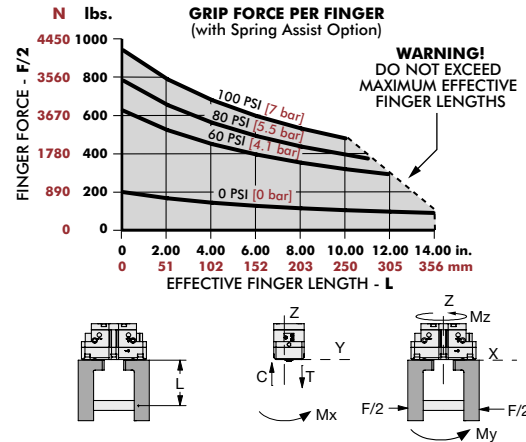
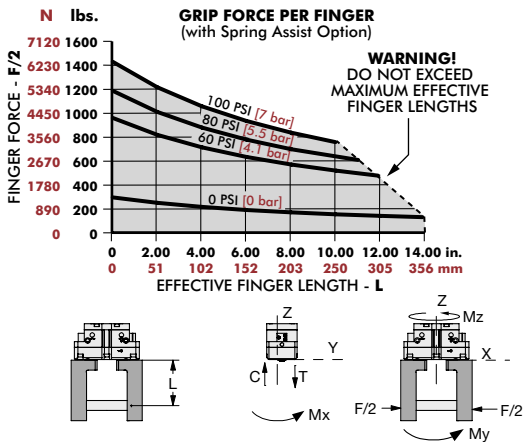

RDH-7M	Static	Dynamic
Maximum Tensile T	4505 N [1013 lbs]	1048 N [236 lbs]
Maximum Compressive C	5938 N [1335 lbs]	1048 N [236 lbs]
Maximum Moment M_x	167 Nm [1478 in-lbs]	36 Nm [319 in-lbs]
Maximum Moment M_y	238 Nm [2106 in-lbs]	51 Nm [451 in-lbs]
Maximum Moment M_z	161 Nm [1425 in-lbs]	51 Nm [451 in-lbs]

*Capacities are per set of jaws and are not simultaneous

RDH-7M-L	Static	Dynamic
Maximum Tensile T	3911 N [879 lbs]	678 N [152 lbs]
Maximum Compressive C	5155 N [1159 lbs]	678 N [152 lbs]
Maximum Moment M_x	145 Nm [1283 in-lbs]	23 Nm [204 in-lbs]
Maximum Moment M_y	179 Nm [1584 in-lbs]	29 Nm [257 in-lbs]
Maximum Moment M_z	122 Nm [1080 in-lbs]	29 Nm [257 in-lbs]

*Capacities are per set of jaws and are not simultaneous

RDH-8M, -8M-L

2-Jaw General Industrial Grippers | Dimensions and Technical Specifications

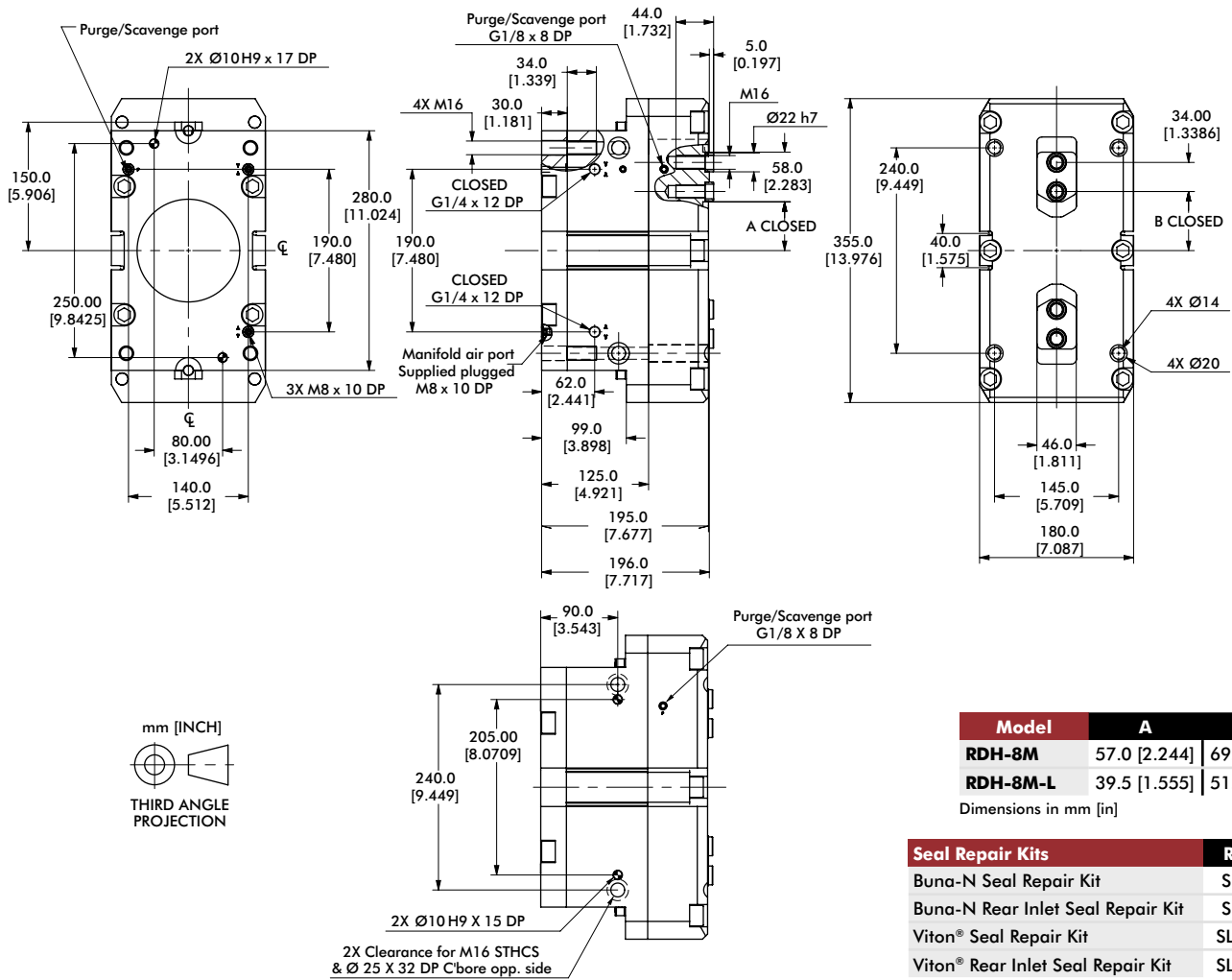

Loading Information

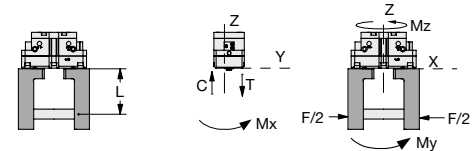
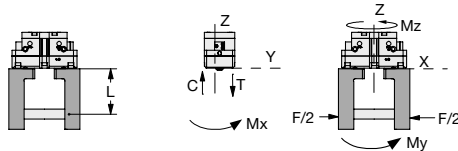
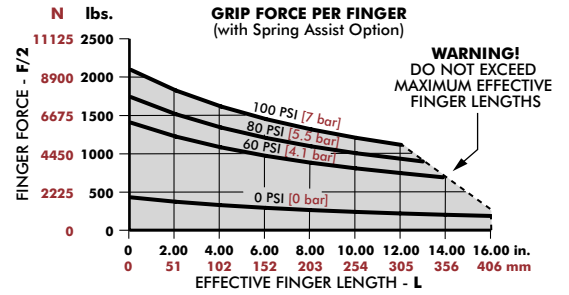
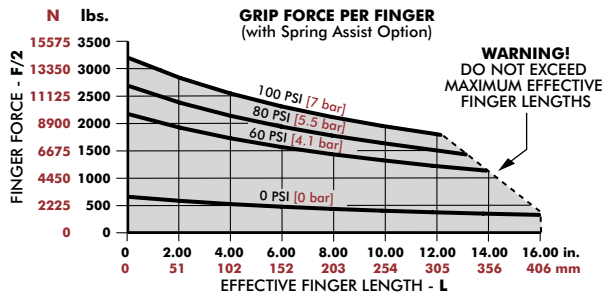

RDH-8M	Static	Dynamic
Maximum Tensile T	6863 N [1543 lbs]	1743 N [392 lbs]
Maximum Compressive C	8921 N [2006 lbs]	1743 N [392 lbs]
Maximum Moment M_x	379 Nm [3354 in-lbs]	84 Nm [743 in-lbs]
Maximum Moment M_y	481 Nm [4257 in-lbs]	107 Nm [947 in-lbs]
Maximum Moment M_z	301 Nm [2664 in-lbs]	107 Nm [947 in-lbs]

RDH-8M-L	Static	Dynamic
Maximum Tensile T	5906 N [1328 lbs]	1125 N [253 lbs]
Maximum Compressive C	7678 N [1726 lbs]	1125 N [253 lbs]
Maximum Moment M_x	326 Nm [2885 in-lbs]	54 Nm [478 in-lbs]
Maximum Moment M_y	357 Nm [3160 in-lbs]	59 Nm [522 in-lbs]
Maximum Moment M_z	223 Nm [1974 in-lbs]	59 Nm [522 in-lbs]

Capacities are per set of jaws and are not simultaneous

Capacities are per set of jaws and are not simultaneous

REP2 SERIES

2-Jaw General Industrial Grippers | Product Features, How to Order

Features:

- Compact cam lever design general purpose gripper
- Pneumatic and Hydraulic operation options
- Spring assist option for part retention in case of air pressure loss
- Standard and extended stroke option available
- Shielded design for harsh environments
- Magneto-resistive and Inductive sensing

Applications:

- Assembly manufacturing cells
- Packaging applications
- General purpose gripping



How To Order

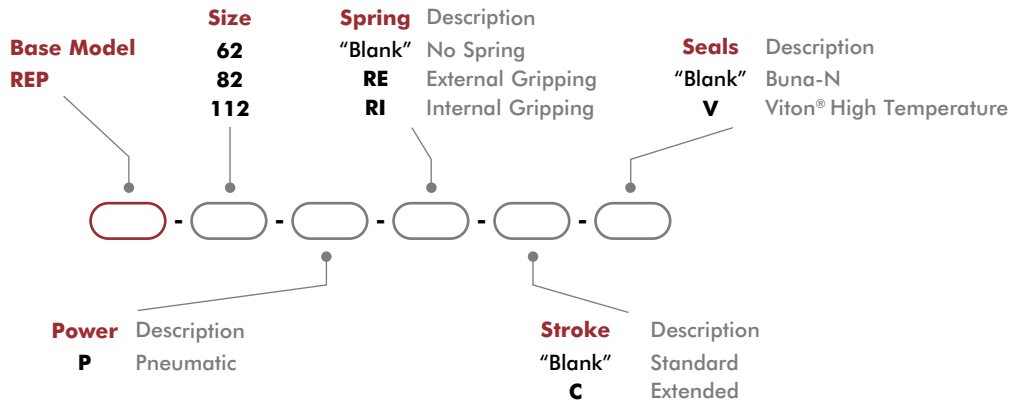

Accessories

Sensor Accessories	Model Numbers	Part Number	Qty/Unit
NPN Inductive Sensor with M8 Quick Disconnect*	All Models	OISN-011	1-4
PNP Inductive Sensor with M8 Quick Disconnect*	All Models	OISP-011	1-4
NPN Magneto Resistive Sensor with Quick Disconnect*†	All Models	OHSN-006	1-2
PNP Magneto Resistive Sensor with Quick Disconnect*†	All Models	OHSP-006	1-2
NPN Magneto Resistive Sensor (Short Barrel) with Qk Disconnect*†	All Models	OHSN-017	1-2
PNP Magneto Resistive Sensor (Short Barrel) with Qk Disconnect*†	All Models	OHSP-017	1-2
M8 Quick Disconnect 2 Meter Cable Length*	All Models	CABL-010	1-4
M8 Quick Disconnect 2 Meter Cable Length*	All Models	CABL-013	1-4
Inductive Sensor Mounting Kit (Mounts 2 Sensors)	62	OSMK-102	1-2
Inductive Sensor Mounting Kit (Mounts 2 Sensors)	82	OSMK-103	1-2
Inductive Sensor Mounting Kit (Mounts 2 Sensors)	112	OSMK-104	1-2

* Sensor and cable sold separately. †The gripper comes with adjustable slots for two magnetic sensors (to control jaw position). Must be used with the -RE or -RI option.

2-Jaw General Industrial Grippers | Technical Specifications

Specifications	Units	62	62-C	82	82-C	112	112-C	
Total Rated Grip Force F @ 100 psi [7 bar]*	N [lbs]	771 [173]	480 [108]	2140 [481]	1382 [311]	3351 [753]	2233 [502]	
Total Stroke	mm [in]	10 [0.394]	16 [0.630]	13 [0.512]	20 [0.787]	20 [0.787]	30 [1.181]	
Weight	kg [lbs]	0.55 [1.2]		0.9 [2.0]		2.45 [5.4]		
Pressure Range w/o Spring	bar [psi]	2-7 [30-100]						
Pressure Range with Spring	bar [psi]	3-7 [45-100]			4-7 [60-100]			
Ingress Protection Class (IP)		IP55						
Displacement	cm ³ [in ³]	12 [0.72]		35 [2.13]		87 [5.31]		
Temperature Range (Buna-N seals)	°C [°F]	-35°~80° [-30°~180°]						
Temperature Range (Viton® seals)	°C [°F]	-30°~150° [-20°~300°]						
Actuation (open/close)	sec	0.10		0.18		0.35		
Accuracy	mm [in]	±0.05 [±0.002]						
Repeatability	mm [in]	±0.02 [±0.0008]						
Valve to Actuate Single Acting		3-way, 2-position						
Valve to Actuate Double Acting		4-way, 2-position						

* with springs

REP-62, -62-C

2-Jaw General Industrial Grippers | Dimensions and Technical Specifications

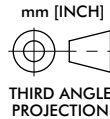
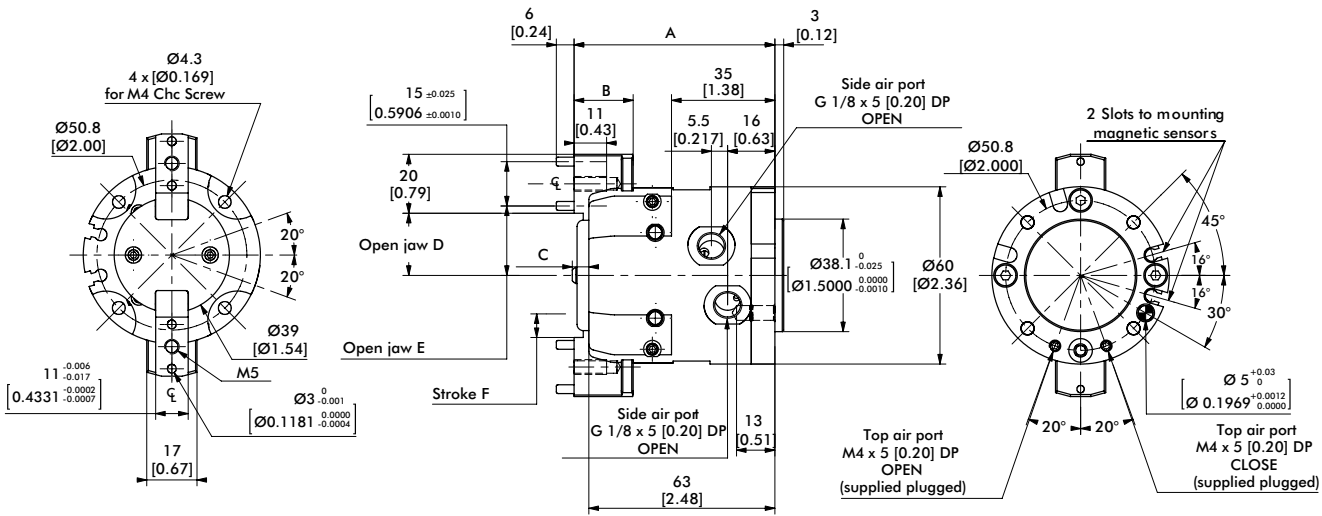

Our grippers are supplied with open side air ports and top air ports plugged. When operating top air ports, produce manifold sealing as shown.

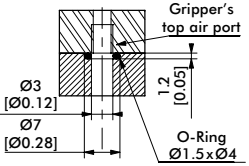

Model	A	B	C	D	E	F	Seal Repair Kits	REP-62
REP-62	64 [2.52]	16 [0.63]	1.6 [0.063]	15 [0.59]	17.5 [0.689]	5 [0.20]	Buna-N Seal Repair Kit	SLKT-155
REP-62-C	68 [2.68]	20 [0.79]	5.6 [0.220]	21 [0.83]	23.5 [0.926]	8 [0.31]	Viton® Seal Repair Kit	SLKT-155V

Loading Information

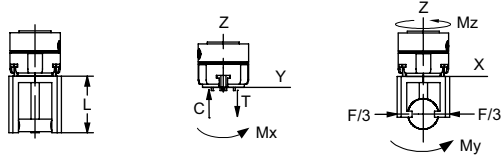
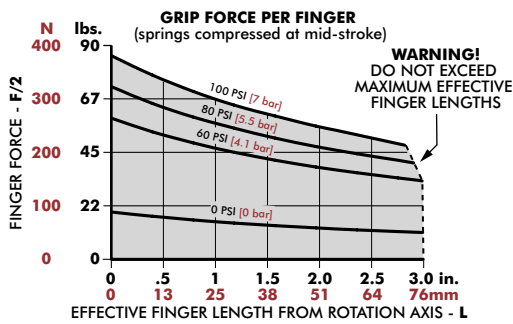

REP-62	Static
Maximum Tensile T	575 N [129 lbs]
Maximum Compressive C	760 N [171 lbs]
Maximum Moment M_x	13 Nm [115 in-lbs]
Maximum Moment M_y	23 Nm [204 in-lbs]
Maximum Moment M_z	36 Nm [319 in-lbs]

[†]Capacities are per set of jaws and are not simultaneous

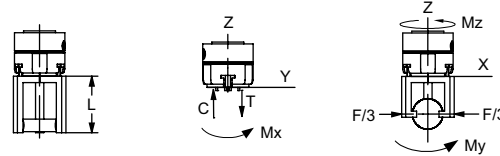
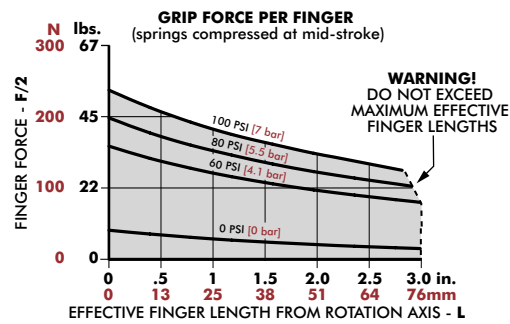

REP-62-C	Static
Maximum Tensile T	575 N [129 lbs]
Maximum Compressive C	760 N [171 lbs]
Maximum Moment M_x	13 Nm [115 in-lbs]
Maximum Moment M_y	23 Nm [204 in-lbs]
Maximum Moment M_z	36 Nm [319 in-lbs]

[†]Capacities are per set of jaws and are not simultaneous

2-Jaw General Industrial Grippers | Dimensions and Technical Specifications

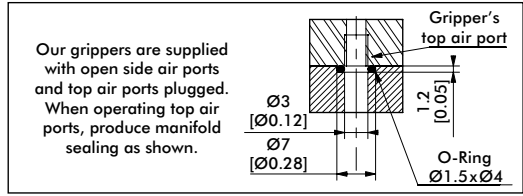
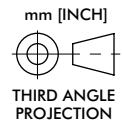
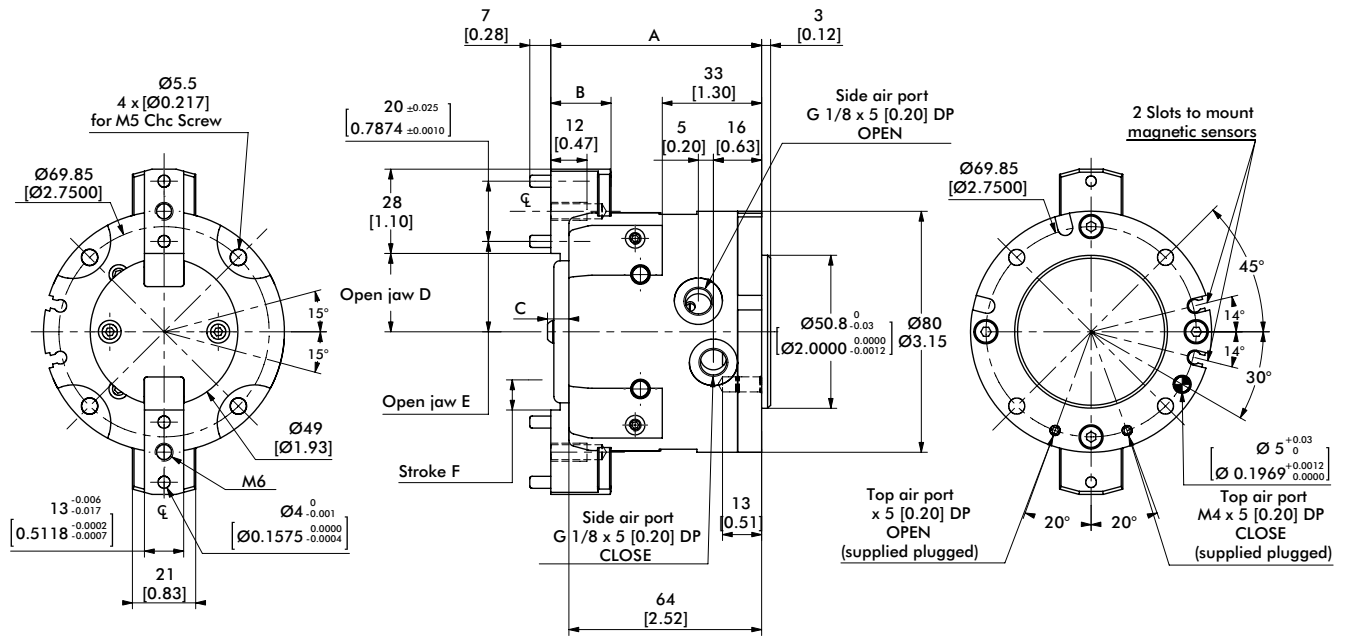

Model	A	B	C	D	E	F
REP-82	65 [2.56]	15 [0.59]	2.1 [0.083]	19 [0.75]	23 [0.91]	6.5 [0.26]
REP-82-C	70 [2.76]	20 [0.79]	7.1 [0.280]	26 [1.02]	30 [1.18]	10 [0.39]

Seal Repair Kits	REP-82
Buna-N Seal Repair Kit	SLKT-157
Viton® Seal Repair Kit	SLKT-157V

Loading Information

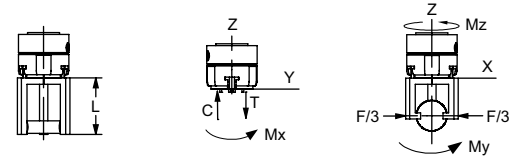
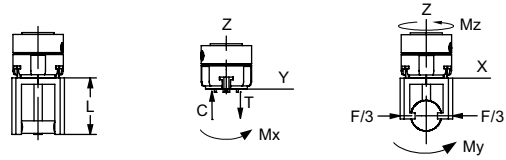
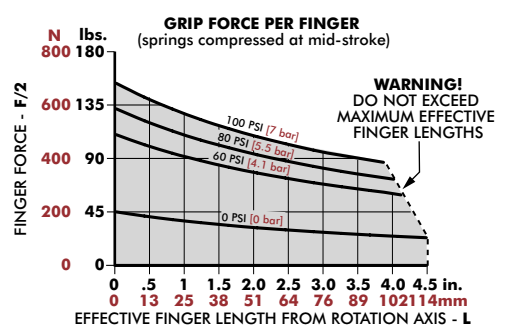
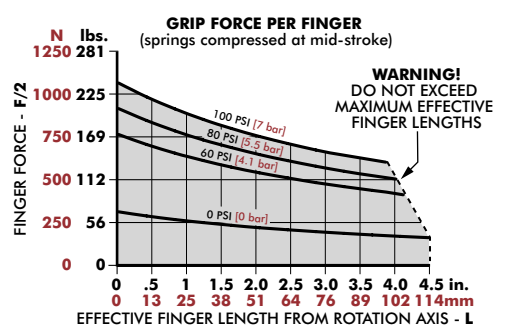

REP-82	Static
Maximum Tensile T	890 N [200 lbs]
Maximum Compressive C	1000 N [225 lbs]
Maximum Moment M_x	22 Nm [195 in-lbs]
Maximum Moment M_y	45 Nm [398 in-lbs]
Maximum Moment M_z	45 Nm [398 in-lbs]

REP-82-C	Static
Maximum Tensile T	810 N [182 lbs]
Maximum Compressive C	910 N [205 lbs]
Maximum Moment M_x	20 Nm [177 in-lbs]
Maximum Moment M_y	40 Nm [354 in-lbs]
Maximum Moment M_z	42 Nm [372 in-lbs]

¹Capacities are per set of jaws and are not simultaneous

¹Capacities are per set of jaws and are not simultaneous

REP-112, -112-C

2-Jaw General Industrial Grippers | Dimensions and Technical Specifications

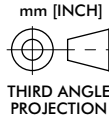
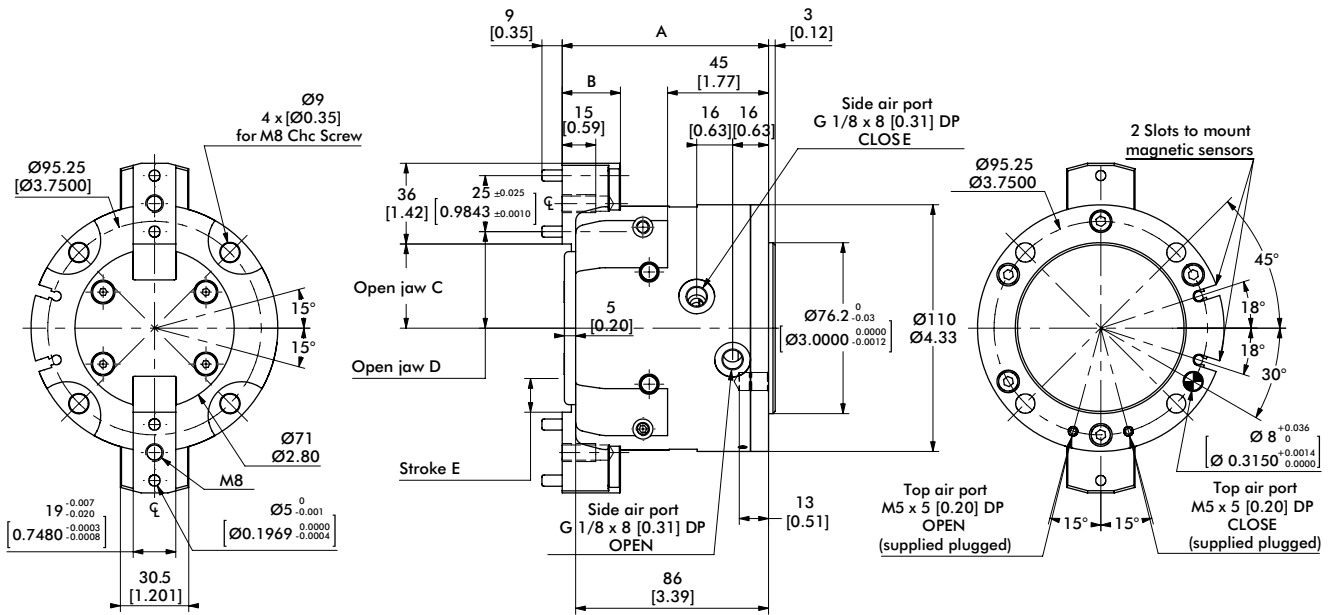

Our grippers are supplied with open side air ports and top air ports plugged. When operating top air ports, produce manifold sealing as shown.

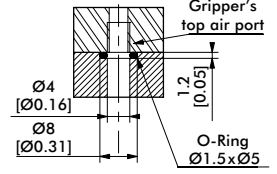

Model	A	B	C	D	E
REP-112	87 [3.43]	21 [0.83]	27.5 [1.083]	33 [1.30]	10 [0.39]
REP-112-C	92 [3.62]	26 [1.02]	37.5 [1.476]	43 [1.69]	15 [0.59]

Seal Repair Kits	REP-112
Buna-N Seal Repair Kit	SLKT-155
Viton® Seal Repair Kit	SLKT-155V

Loading Information

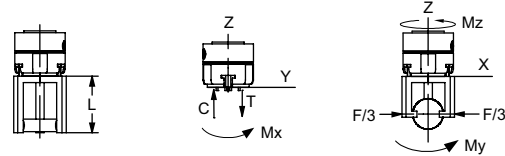
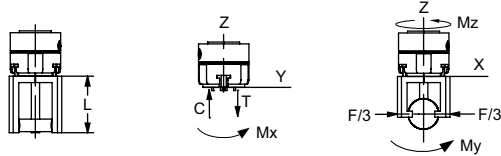
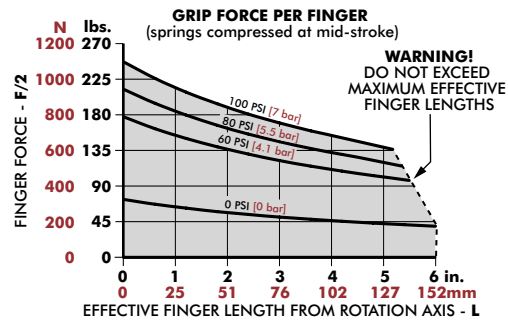
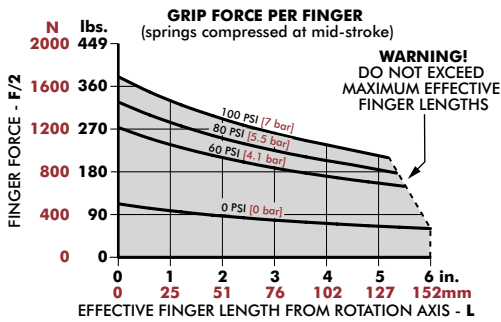

REP-112	Static
Maximum Tensile T	1320 N [297 lbs]
Maximum Compressive C	1430 N [321 lbs]
Maximum Moment M_x	44 Nm [389 in-lbs]
Maximum Moment M_y	75 Nm [664 in-lbs]
Maximum Moment M_z	70 Nm [620 in-lbs]

[†]Capacities are per set of jaws and are not simultaneous

REP-112-C	Static
Maximum Tensile T	1320 N [297 lbs]
Maximum Compressive C	1430 N [321 lbs]
Maximum Moment M_x	38 Nm [336 in-lbs]
Maximum Moment M_y	75 Nm [664 in-lbs]
Maximum Moment M_z	70 Nm [620 in-lbs]

[†]Capacities are per set of jaws and are not simultaneous

RP5-10 SERIES

2-Jaw General Industrial Grippers | Product Features, How to Order

Features:

- Widely used robust miniature gripper
- Double wedge design for high impact applications
- Spring assist option for part retention in case of air pressure loss
- Create gripper arrays with close proximity mounting for multiple part pick and place
- Grip force range from 156N [35 lbs] to 178N [40 lbs]
- Stroke Range from 4.1mm [0.16 in] to 6.4mm [0.25 in]

Applications:

- Ideal for small part gripping solutions
- Used with small robots
- Packaging applications
- Multiple part transfers using banks of grippers



RP-10



RP-5, 5-FS



(USB key shown for scale)

How To Order

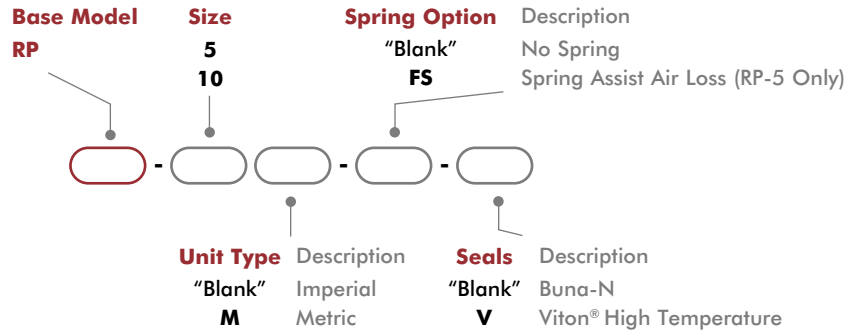

Accessories

Sensor Accessories	Model Numbers	Part Number	Qty/Unit
Sensor Mounting Kit for Imperial & Metric Units (mounts 2 sensors)	RP-5	OSMK-001	1
Sensor Mounting Kit for Imperial & Metric Units (mounts 2 sensors)	RP-10	OSMK-002	1
NPN Inductive Sensor with Quick Disconnect*	All Models	OISN-019	1-2
PNP Inductive Sensor with Quick Disconnect*	All Models	OISP-019	1-2
Quick Disconnect 2 Meter Cable Length*	All Models	CABL-010	1-2
Quick Disconnect 5 Meter Cable Length*	All Models	CABL-013	1-2
Pneumatic Accessories	Model Numbers	Part Number	Qty/Unit
Fail Safe Valve (Imperial)	All Models	OFSV-001	1
Fail Safe Valve (Metric)	All Models	OFSV-004	1

* Sensor and cable sold separately.

RP5-10 SERIES

2-Jaw General Industrial Grippers | Technical Specifications

Specifications	Units	5	5-FS	10
Total Rated Grip Force F @ 100 psi [7 bar]	N [lbs]	156 [35]	178 [40]	
Total Stroke	mm [in]	4.1 [0.16]		6.4 [0.25]
Weight	kg [lbs]	0.08 [0.18]		0.13 [0.28]
Pressure Range	bar [psi]	3-7 [40-100]		
Ingress Protection Class (IP)		IP43		
Displacement	cm ³ [in ³]	0.7 [0.042]		1.6 [0.098]
Temperature Range (Buna-N seals)	°C [°F]	-35°~80° [-30°~180°]		
Temperature Range (Viton® seals)	°C [°F]	-30°~150° [-20°~300°]		
Actuation	sec	0.14		0.13
Accuracy	mm [in]	±0.03 [±0.001]		
Repeatability	mm [in]	±0.01 [±0.0005]		
Valve to Actuate		4-way, 2-position		

RP-5

2-Jaw Parallel Grippers | Dimensions and Technical Specifications

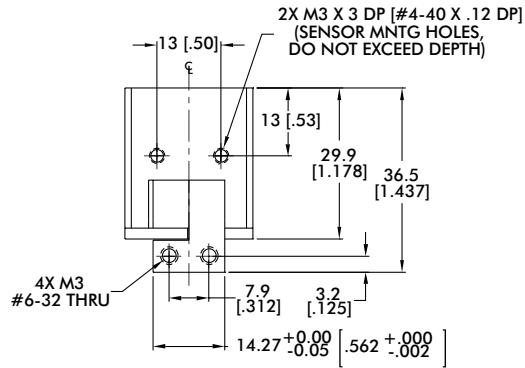
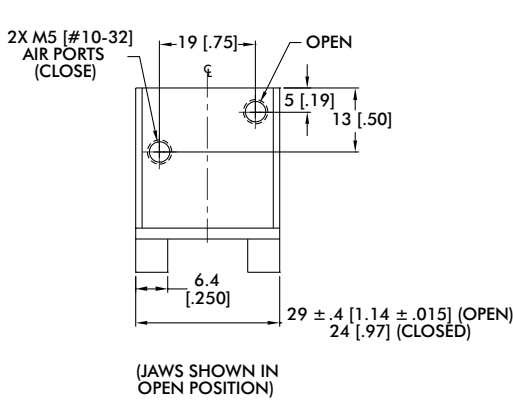
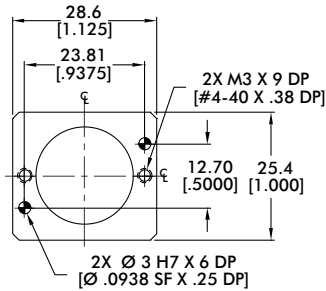

Seal Repair Kits	RP-5
Buna-N Seal Repair Kit	SLKT-052
Viton® Seal Repair Kit	SLKT-052V

Loading Information

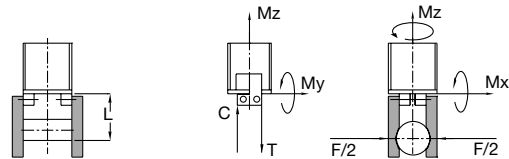
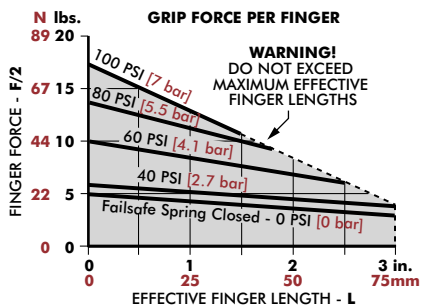

RP-5	Static	Dynamic
Maximum Tensile T	222 N [50 lbs]	31 N [7 lbs]
Maximum Compressive C	334 N [75 lbs]	53 N [12 lbs]
Maximum Moment M_x	3.4 Nm [30 in-lbs]	0.6 Nm [5 in-lbs]
Maximum Moment M_y	3.4 Nm [30 in-lbs]	0.6 Nm [5 in-lbs]
Maximum Moment M_z	3.4 Nm [30 in-lbs]	0.6 Nm [5 in-lbs]

*Capacities are per set of jaws and are not simultaneous

2-Jaw Parallel Grippers | Dimensions and Technical Specifications

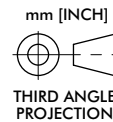
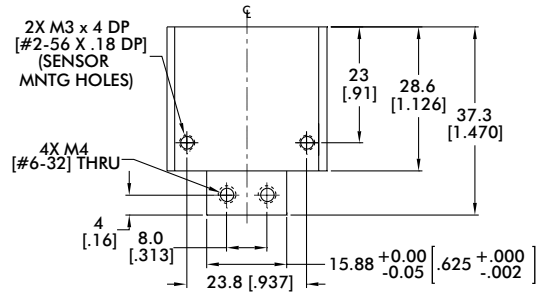
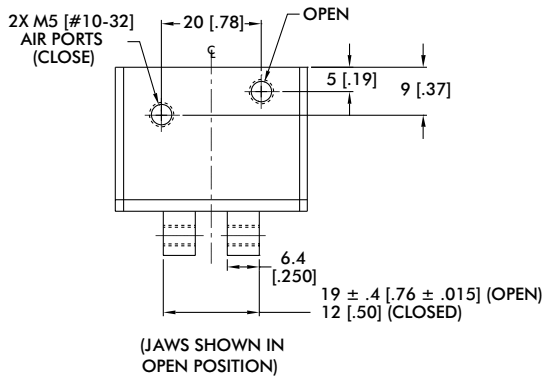
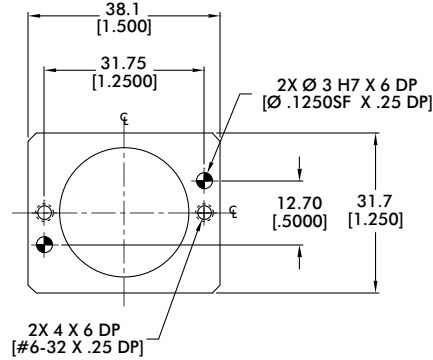

Seal Repair Kits	RP-10
Buna-N Seal Repair Kit	SLKT-136
Viton® Seal Repair Kit	SLKT-136V

Loading Information

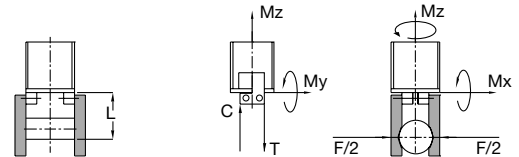
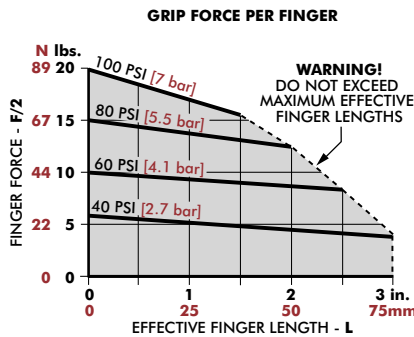

RP-10	Static	Dynamic
Maximum Tensile T	445 N [100 lbs]	67 N [15 lbs]
Maximum Compressive C	667 N [150 lbs]	111 N [25 lbs]
Maximum Moment M_x	10.2 Nm [90 in-lbs]	1.5 Nm [15 in-lbs]
Maximum Moment M_y	10.2 Nm [90 in-lbs]	1.5 Nm [15 in-lbs]
Maximum Moment M_z	10.2 Nm [90 in-lbs]	1.5 Nm [15 in-lbs]

*Capacities are per set of jaws and are not simultaneous

RP SERIES

2-Jaw General Industrial Parallel Grippers | Features and Benefits | How To Order

Features:

- Widely used robust sealed design gripper
- Double wedge design for high impact applications
- Hardened steel bottom for part pressing applications
- Inductive jaw location sensing
- Grip force range from 178N [40 lbs] to 2669N [600 lbs]
- Stroke Range from 6.4mm [0.25 in] to 50.8mm [2.00 in]

Applications:

- Inline part pressing applications
- OEM machine pick and place
- Packaging applications
- Automotive assembly



U.S. Patent #5,125,708

How To Order

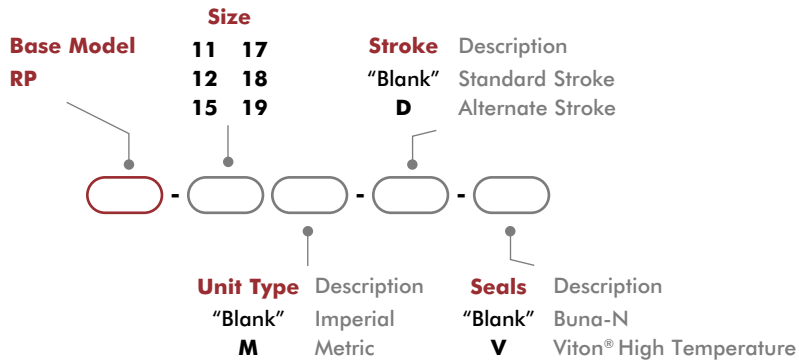

Accessories

Sensor Accessories	Model Numbers	Part Number	Qty/Unit
Sensor Mounting Kit for Imperial & Metric Units (mounts 2 sensors)	See Datasheet		1
NPN Inductive Sensor with Quick Disconnect*	11, 12, 15	OISN-019	1-2
PNP Inductive Sensor with Quick Disconnect*	11, 12, 15	OISP-019	1-2
NPN Inductive Sensor with Quick Disconnect*	17, 18, 19	OISN-011	1-2
PNP Inductive Sensor with Quick Disconnect*	17, 18, 19	OISP-011	1-2
Quick Disconnect 2 Meter Cable Length*	All Models	CABL-010	1-2
Quick Disconnect 5 Meter Cable Length*	All Models	CABL-013	1-2

Pneumatic Accessories	Model Numbers	Part Number	Qty/Unit
Fail Safe Valve (Imperial)	See Datasheet		1
Fail Safe Valve (Metric)	See Datasheet		1

* Sensor and cable sold separately.

2-Jaw General Industrial Parallel Grippers | Technical Specifications

Specifications	Units	11	11-D	12	12-D	15	15-D
Total Rated Grip Force F @ 100 psi [7 bar]	N [lbs]	178 [40]	312 [70]	178 [40]	267 [60]	310 [70]	445 [100]
Total Stroke	mm [in]	6.4 [0.25]	4 [0.16]	9.5 [0.38]	6 [0.24]	12.7 [0.50]	8 [0.31]
Weight	kg [lbs]	0.12 [0.26]		0.25 [0.56]		0.57 [1.25]	
Pressure Range	bar [psi]	3-7 [40-100]					
Ingress Protection Class (IP)		IP43					
Displacement	cm ³ [in ³]	1.6 [0.098]		2.5 [0.150]		4.9 [0.300]	
Temperature Range (Buna-N seals)	°C [°F]	-35°~80° [-30°~180°]					
Temperature Range (Viton® seals)	°C [°F]	-30°~150° [-20°~300°]					
Actuation	sec	0.13				0.20	
Accuracy	mm [in]	±0.05 [±0.002]					
Repeatability	mm [in]	±0.03 [±0.001]					
Valve to Actuate		4-way, 2-position					

Specifications	Units	17	17-D	18	18-D	19	19-D
Total Rated Grip Force F @ 100 psi [7 bar]	N [lbs]	979 [220]	578 [130]	1779 [400]	1112 [250]	2669 [600]	3336 [750]
Total Stroke	mm [in]	19.1 [0.75]	28 [1.10]	31.8 [1.25]	43 [1.70]	50.8 [2.00]	38.1 [1.50]
Weight	kg [lbs]	1.0 [2.2]		3.5 [7.7]		9.5 [21]	
Pressure Range	bar [psi]	3-7 [40-100]					
Ingress Protection Class (IP)		IP43					
Displacement	cm ³ [in ³]	22.9 [1.400]		72.1 [4.400]		157.3 [9.600]	
Temperature Range (Buna-N seals)	°C [°F]	-35°~80° [-30°~180°]					
Temperature Range (Viton® seals)	°C [°F]	-30°~150° [-20°~300°]					
Actuation	sec	0.18		0.22		0.50	
Accuracy	mm [in]	±0.08 [±0.003]					
Repeatability	mm [in]	±0.03 [±0.001]					
Valve to Actuate		4-way, 2-position					

RP-11

2-Jaw General Industrial Parallel Grippers | Dimensions and Technical Specifications

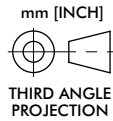
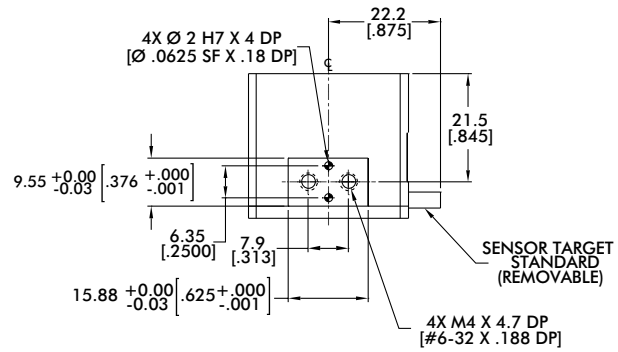
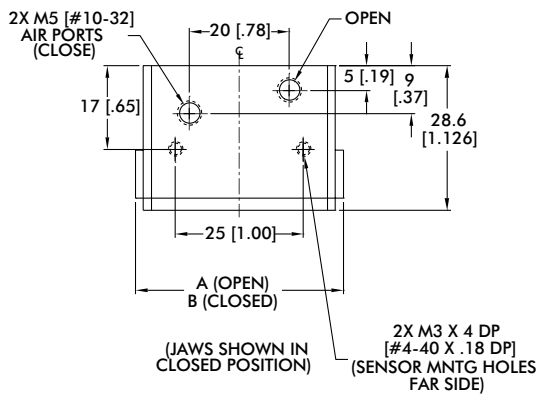
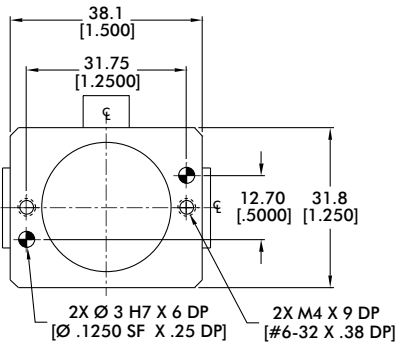

Model	A	B
RP-11	48 [1.88]	41 [1.63]
RP-11-D	45 [1.79]	

Loading Information

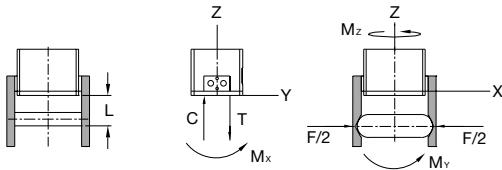
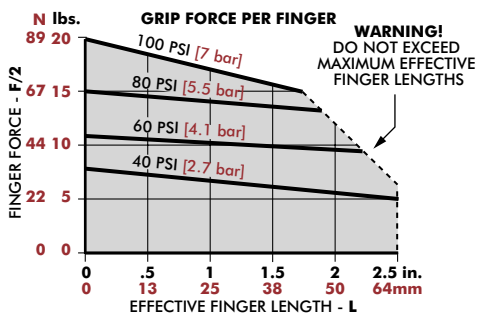

RP-11	Static	Dynamic
Maximum Tensile T	445 N [100 lbs]	111 N [25 lbs]
Maximum Compressive C	890 N [200 lbs]	111 N [25 lbs]
Maximum Moment M_x	11 Nm [100 in-lbs]	2 Nm [17 in-lbs]
Maximum Moment M_y	11 Nm [100 in-lbs]	2 Nm [17 in-lbs]
Maximum Moment M_z	11 Nm [100 in-lbs]	2 Nm [17 in-lbs]

*Capacities are per set of jaws and are not simultaneous

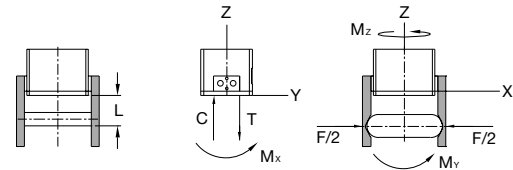
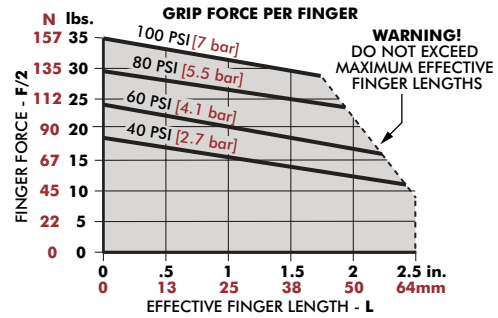

RP-11-D	Static	Dynamic
Maximum Tensile T	445 N [100 lbs]	111 N [25 lbs]
Maximum Compressive C	890 N [200 lbs]	111 N [25 lbs]
Maximum Moment M_x	11 Nm [100 in-lbs]	2 Nm [17 in-lbs]
Maximum Moment M_y	11 Nm [100 in-lbs]	2 Nm [17 in-lbs]
Maximum Moment M_z	11 Nm [100 in-lbs]	2 Nm [17 in-lbs]

*Capacities are per set of jaws and are not simultaneous

2-Jaw General Industrial Parallel Grippers | Dimensions and Technical Specifications

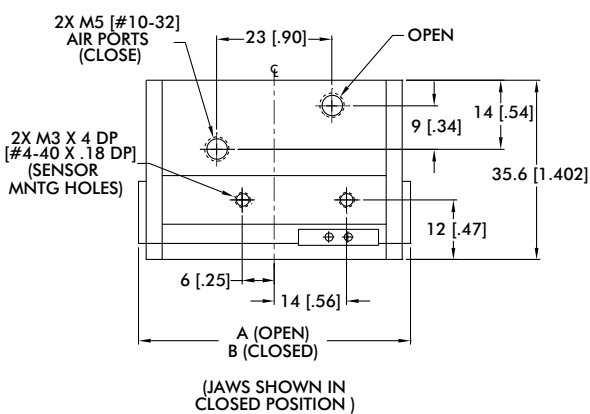
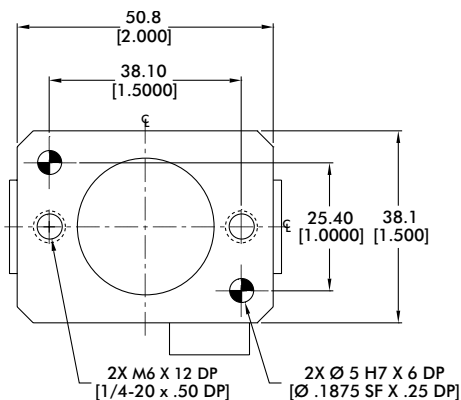

Model	A	B
RP-12	63 [2.50]	54 [2.13]
RP-12-D	60 [2.37]	

Sensor Accessories	RP-12
Inductive Sensor Mounting Kit (mounts 2 sensors)	OSMK-003

Seal Repair Kits	RP-12
Buna-N Seal Repair Kit	SLKT-040
Viton® Seal Repair Kit	SLKT-040V

Pneumatic Accessories	RP-12
Fail Safe Valve (Imperial)	OFSV-001
Fail Safe Valve (Metric)	OFSV-004

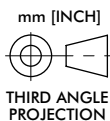
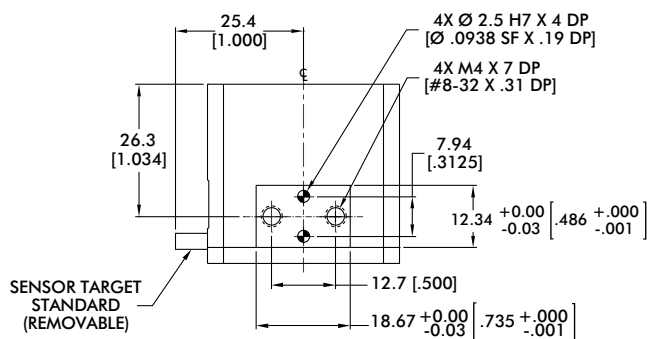

Loading Information

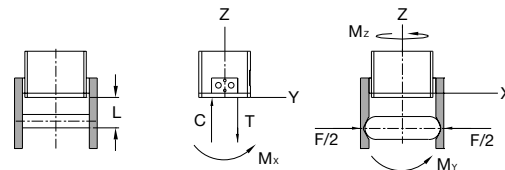
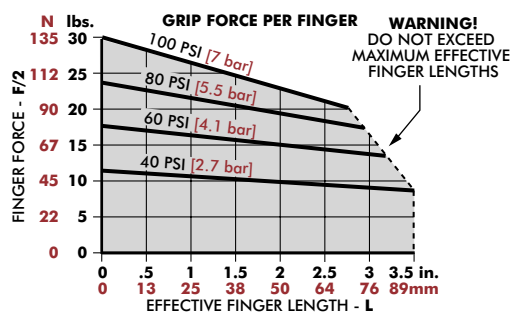
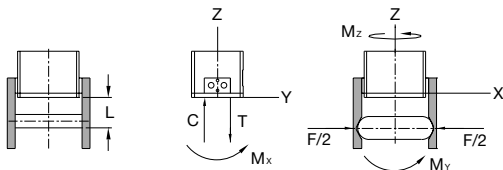
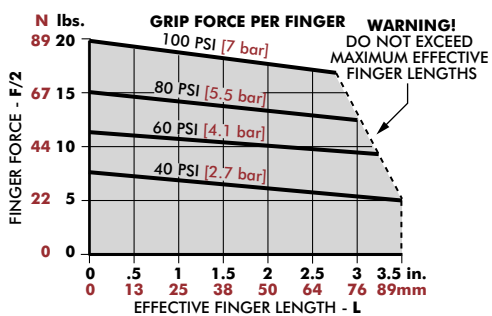

RP-12	Static	Dynamic
Maximum Tensile T	890 N [200 lbs]	111 N [25 lbs]
Maximum Compressive C	1779 N [400 lbs]	111 N [25 lbs]
Maximum Moment M_x	17 Nm [150 in-lbs]	3 Nm [25 in-lbs]
Maximum Moment M_y	17 Nm [150 in-lbs]	3 Nm [25 in-lbs]
Maximum Moment M_z	17 Nm [150 in-lbs]	3 Nm [25 in-lbs]

Capacities are per set of jaws and are not simultaneous

RP-12-D	Static	Dynamic
Maximum Tensile T	890 N [200 lbs]	111 N [25 lbs]
Maximum Compressive C	1779 N [400 lbs]	111 N [25 lbs]
Maximum Moment M_x	17 Nm [150 in-lbs]	3 Nm [25 in-lbs]
Maximum Moment M_y	17 Nm [150 in-lbs]	3 Nm [25 in-lbs]
Maximum Moment M_z	17 Nm [150 in-lbs]	3 Nm [25 in-lbs]

Capacities are per set of jaws and are not simultaneous

RP-15

2-Jaw General Industrial Parallel Grippers | Dimensions and Technical Specifications

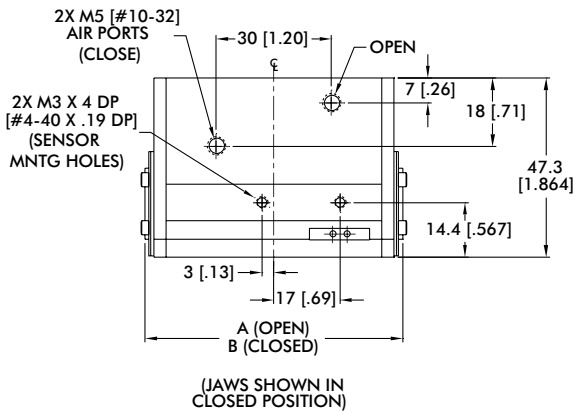
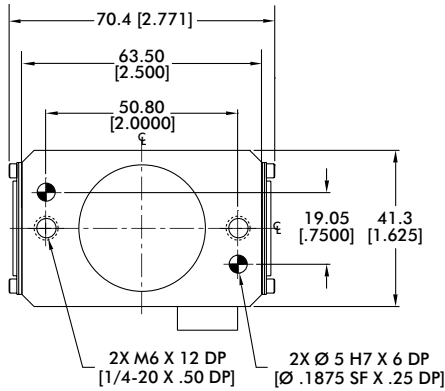

Model	A	B
RP-15	81 [3.19]	68 [2.69]
RP-15-D	76 [3.00]	68 [2.69]

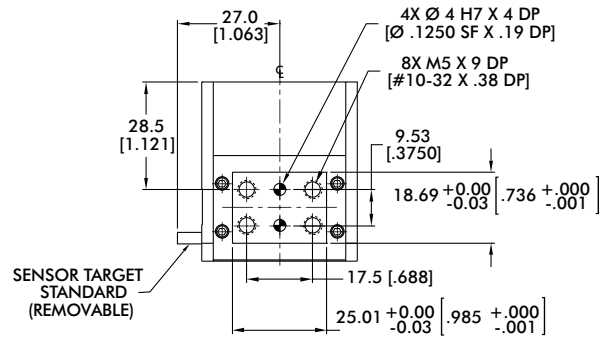
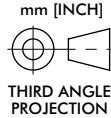

Loading Information

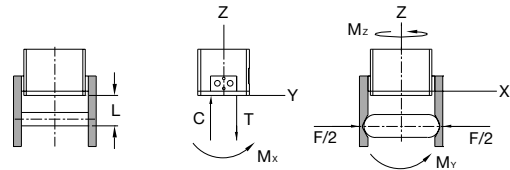
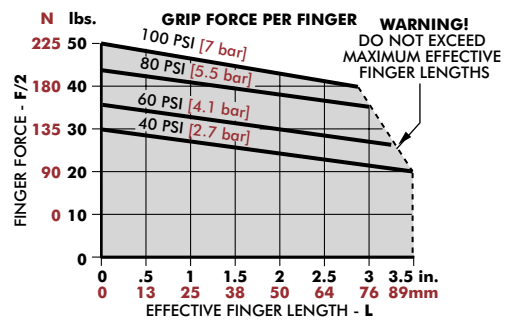
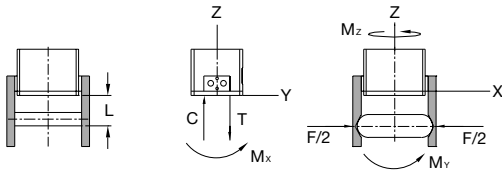
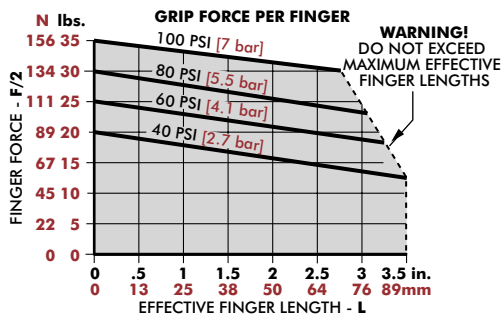

RP-15	Static	Dynamic
Maximum Tensile T	1779 N [400 lbs]	222 N [50 lbs]
Maximum Compressive C	3336 N [750 lbs]	222 N [50 lbs]
Maximum Moment M_x	34 Nm [300 in-lbs]	6 Nm [50 in-lbs]
Maximum Moment M_y	34 Nm [300 in-lbs]	6 Nm [50 in-lbs]
Maximum Moment M_z	34 Nm [300 in-lbs]	6 Nm [50 in-lbs]

*Capacities are per set of jaws and are not simultaneous

RP-15-D	Static	Dynamic
Maximum Tensile T	1779 N [400 lbs]	222 N [50 lbs]
Maximum Compressive C	3336 N [750 lbs]	222 N [50 lbs]
Maximum Moment M_x	34 Nm [300 in-lbs]	6 Nm [50 in-lbs]
Maximum Moment M_y	34 Nm [300 in-lbs]	6 Nm [50 in-lbs]
Maximum Moment M_z	34 Nm [300 in-lbs]	6 Nm [50 in-lbs]

*Capacities are per set of jaws and are not simultaneous

2-Jaw General Industrial Parallel Grippers | Dimensions and Technical Specifications

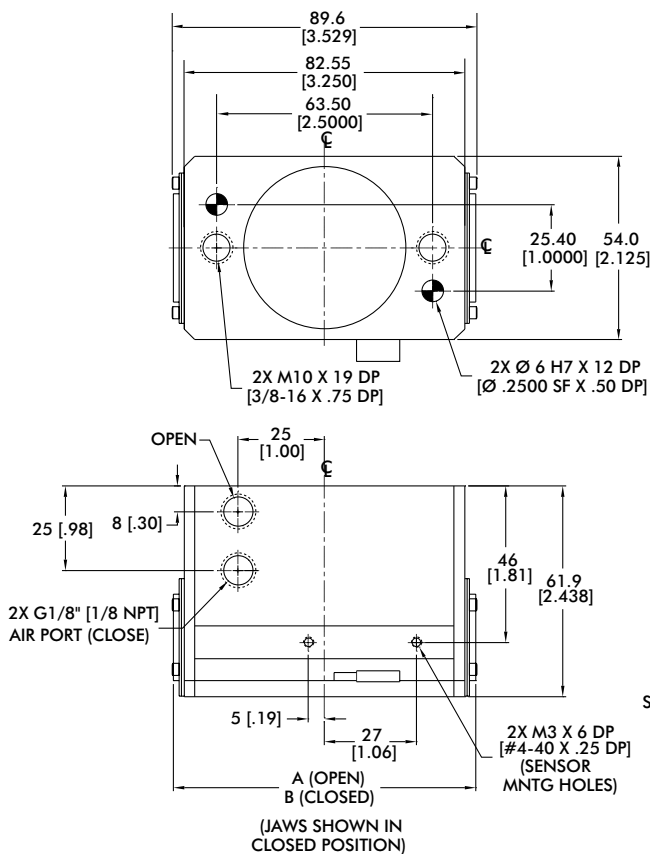

Model	A	B
RP-17	107 [4.25]	89 [3.50]
RP-17-D	117 [4.60]	

Sensor Accessories	RP-17
Inductive Sensor Mounting Kit (mounts 2 sensors)	OSMK-072
Seal Repair Kits	RP-17
Buna-N Seal Repair Kit	SLKT-042
Viton® Seal Repair Kit	SLKT-042V
Pneumatic Accessories	RP-17
Fail Safe Valve (Imperial)	OFSV-002
Fail Safe Valve (Metric)	OFSV-005

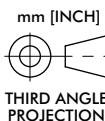
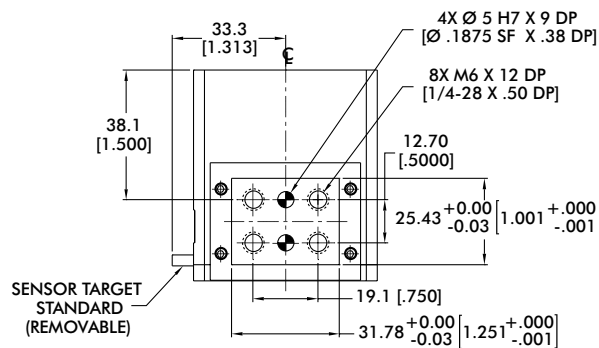

Loading Information

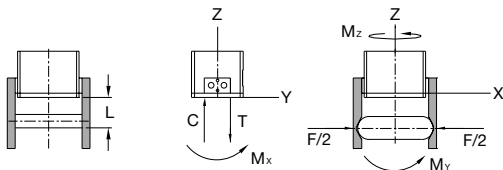
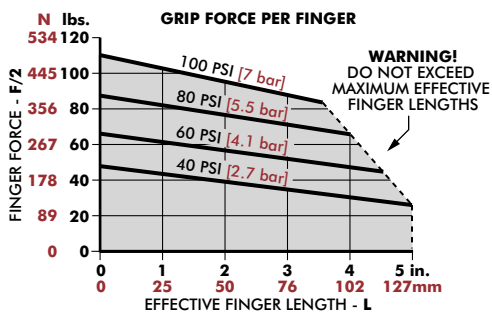

RP-17	Static	Dynamic
Maximum Tensile T	3336 N [750 lbs]	445 N [100 lbs]
Maximum Compressive C	6672 N [1500 lbs]	445 N [100 lbs]
Maximum Moment M_x	85 Nm [750 in-lbs]	14 Nm [125 in-lbs]
Maximum Moment M_y	85 Nm [750 in-lbs]	14 Nm [125 in-lbs]
Maximum Moment M_z	85 Nm [750 in-lbs]	14 Nm [125 in-lbs]

¹Capacities are per set of jaws and are not simultaneous

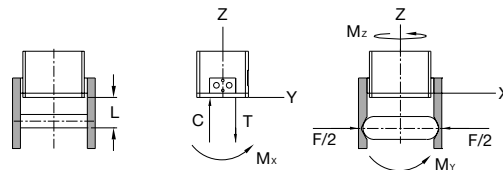
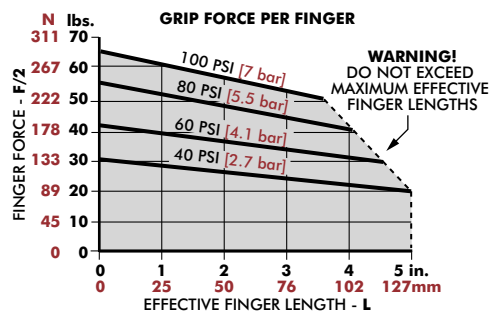

RP-17-D	Static	Dynamic
Maximum Tensile T	3336 N [750 lbs]	445 N [100 lbs]
Maximum Compressive C	6672 N [1500 lbs]	445 N [100 lbs]
Maximum Moment M_x	85 Nm [750 in-lbs]	14 Nm [125 in-lbs]
Maximum Moment M_y	85 Nm [750 in-lbs]	14 Nm [125 in-lbs]
Maximum Moment M_z	85 Nm [750 in-lbs]	14 Nm [125 in-lbs]

¹Capacities are per set of jaws and are not simultaneous

RP-18

2-Jaw General Industrial Parallel Grippers | Dimensions and Technical Specifications

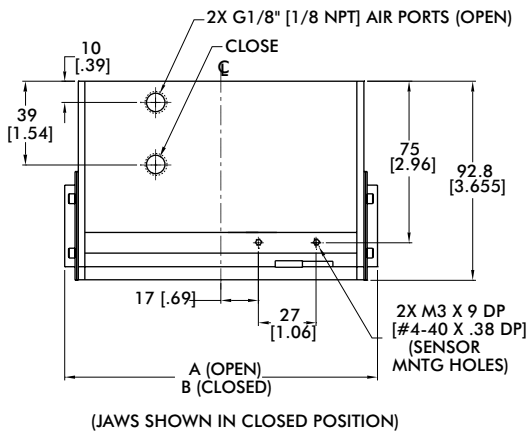
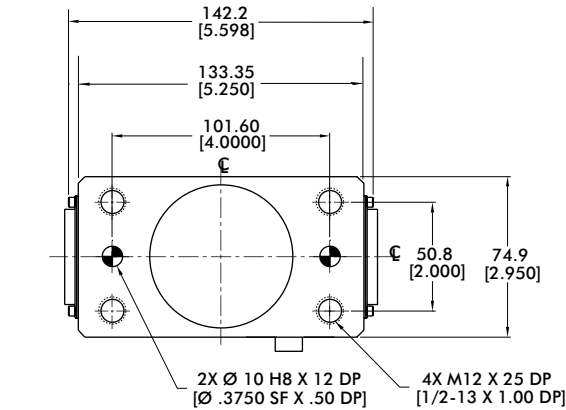

Model	A	B
RP-18	177 [7.00]	
RP-18-D	190 [7.45]	146 [5.75]

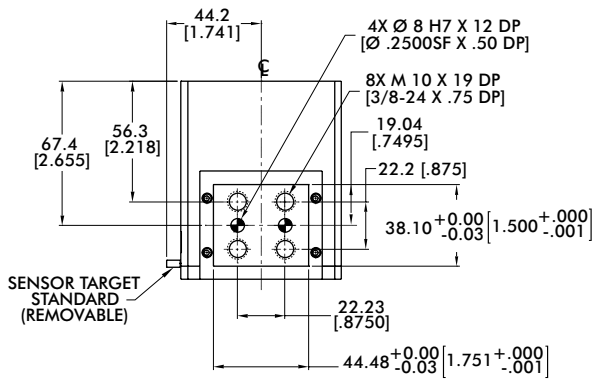
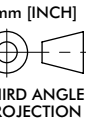

Sensor Accessories	RP-18
Inductive Sensor Mounting Kit (mounts 2 sensors)	OSMK-072

Seal Repair Kits	RP-18
Buna-N Seal Repair Kit	SLKT-043
Viton® Seal Repair Kit	SLKT-043V

Pneumatic Accessories	RP-18
Fail Safe Valve (Imperial)	OFSV-002
Fail Safe Valve (Metric)	OFSV-005

Loading Information

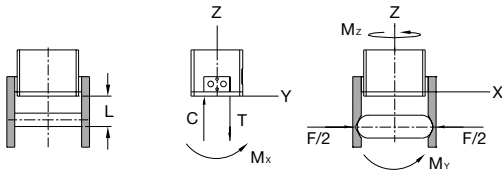
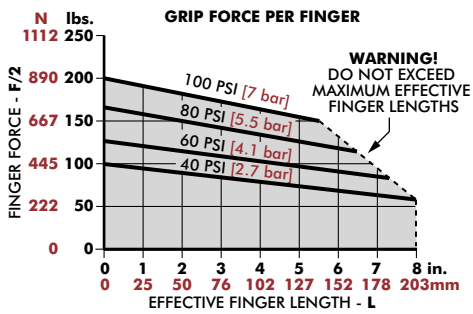

RP-18	Static	Dynamic
Maximum Tensile T	6672 N [1500 lbs]	1112 N [250 lbs]
Maximum Compressive C	13345 N [3000 lbs]	1112 N [250 lbs]
Maximum Moment M_x	170 Nm [1500 in-lbs]	28 Nm [250 in-lbs]
Maximum Moment M_y	170 Nm [1500 in-lbs]	28 Nm [250 in-lbs]
Maximum Moment M_z	170 Nm [1500 in-lbs]	28 Nm [250 in-lbs]

*Capacities are per set of jaws and are not simultaneous

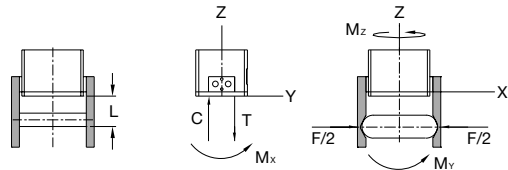
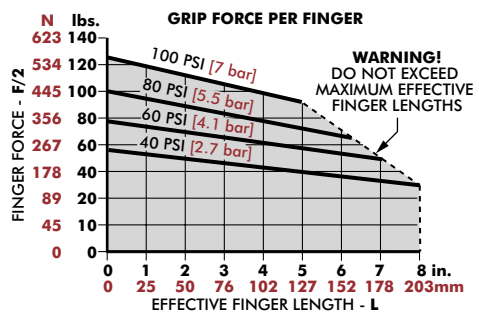

RP-18-D	Static	Dynamic
Maximum Tensile T	6672 N [1500 lbs]	1112 N [250 lbs]
Maximum Compressive C	13345 N [3000 lbs]	1112 N [250 lbs]
Maximum Moment M_x	170 Nm [1500 in-lbs]	28 Nm [250 in-lbs]
Maximum Moment M_y	170 Nm [1500 in-lbs]	28 Nm [250 in-lbs]
Maximum Moment M_z	170 Nm [1500 in-lbs]	28 Nm [250 in-lbs]

*Capacities are per set of jaws and are not simultaneous

2-Jaw General Industrial Parallel Grippers | Dimensions and Technical Specifications

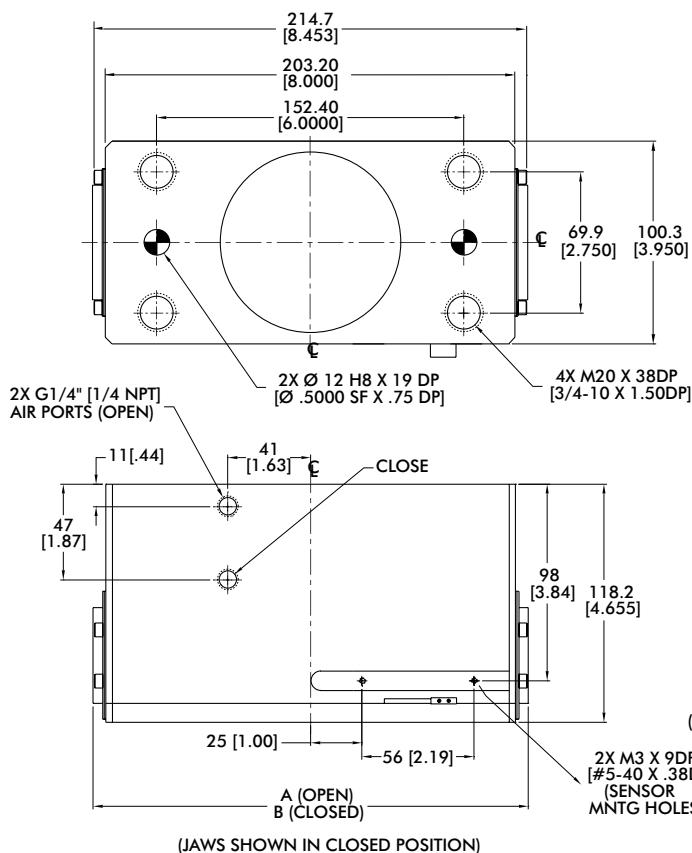

Model	A	B
RP-19	266 [10.50]	216 [8.50]
RP-19-D	254 [10.00]	

Sensor Accessories	RP-19
Inductive Sensor Mounting Kit (mounts 2 sensors)	OSMK-073

Seal Repair Kits	RP-19
Buna-N Seal Repair Kit	SLKT-044
Viton® Seal Repair Kit	SLKT-044V

Pneumatic Accessories	RP-19
Fail Safe Valve (Imperial)	OFSV-003
Fail Safe Valve (Metric)	OFSV-006

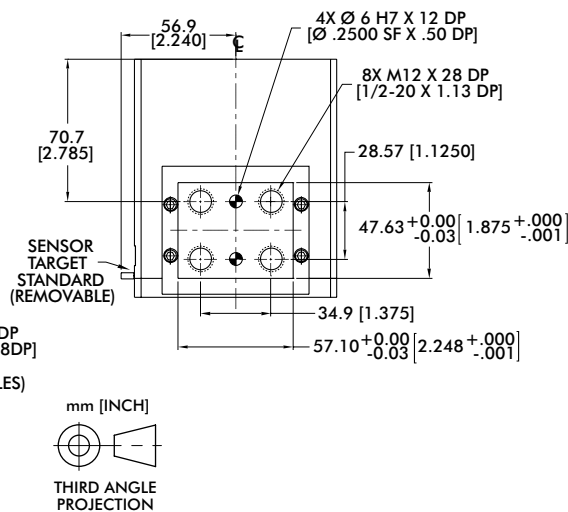

Loading Information

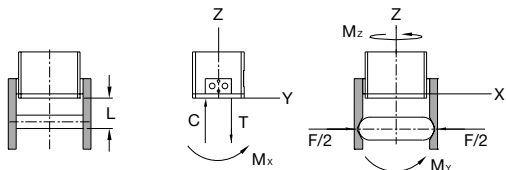
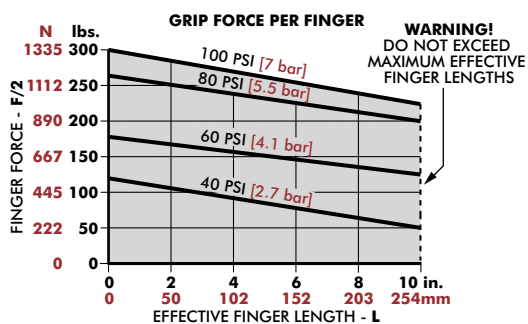

RP-19	Static	Dynamic
Maximum Tensile T	13345 N [3000 lbs]	1334 N [300 lbs]
Maximum Compressive C	26689 N [6000 lbs]	1334 N [300 lbs]
Maximum Moment M_x	565 Nm [5000 in-lbs]	56 Nm [500 in-lbs]
Maximum Moment M_y	565 Nm [5000 in-lbs]	56 Nm [500 in-lbs]
Maximum Moment M_z	565 Nm [5000 in-lbs]	56 Nm [500 in-lbs]

[†]Capacities are per set of jaws and are not simultaneous

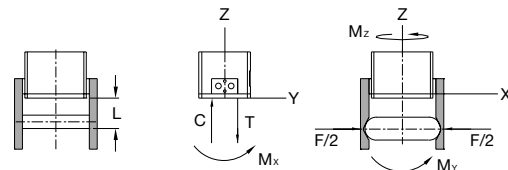
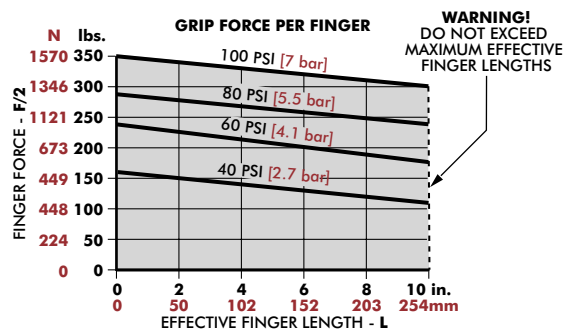

RP-19-D	Static	Dynamic
Maximum Tensile T	13345 N [3000 lbs]	1334 N [300 lbs]
Maximum Compressive C	26689 N [6000 lbs]	1334 N [300 lbs]
Maximum Moment M_x	565 Nm [5000 in-lbs]	56 Nm [500 in-lbs]
Maximum Moment M_y	565 Nm [5000 in-lbs]	56 Nm [500 in-lbs]
Maximum Moment M_z	565 Nm [5000 in-lbs]	56 Nm [500 in-lbs]

[†]Capacities are per set of jaws and are not simultaneous

RPM/RPMC SERIES

2-Jaw General Industrial Grippers | Features and Benefits | How To Order

Features:

- Miniature gripper for small part gripping
- Zero side play due to Dual V bearing system
- Low friction and smooth operation for precise part position repeatability
- Create compact gripper arrays with top manifold design
- Adjustable pre-load screws eliminates side play over life of unit
- Purge and scavenge ports for clean/harsh environment operation
- Units are lubricated with clean-room grease
- Class 10 rated clean-room (RPMC)



Applications:

- Ideal for semiconductor and life sciences laboratory applications
- Ultra small gripper for space constrained applications
- Sealed design operates in harsh environments (RPMC)
- Viton® seals option for High temperature applications
-30°C to +150°C [-20°F to +300°F]

How To Order

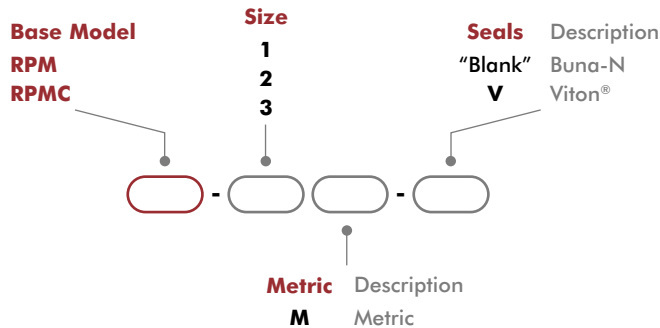

Accessories

Pneumatic Accessories	Model Numbers	Part Number	Qty/Unit
M3 Plumbing Fitting Push-in for 3mm O.D. Tube	All Models	PLFT-021	2
M3 Plumbing Fitting Barb for 2mm I.D. Tube	All Models	PLFT-022	2
Buna-N Seal Repair Kit	All Models	SLKT-121	1
Viton® Seal Repair Kit	All Models	SLKT-121V	1
Top Air Ports Manifold Seal Kit (available in Viton® only)	All Models (RPM)	SLKT-142V	1
Top Air Ports Manifold Seal Kit (available in Viton® only)	All Models (RPMC)	SLKT-143V	1

RPM/RPMC SERIES

2-Jaw General Industrial Grippers | Technical Specifications

Specifications	Units	1	2	3
Total Rated Grip Force F @ 100 psi [7 bar]	N [lbs]	36 [8]		
Total Stroke	mm [in]	3.2 [0.13]	4.8 [0.19]	6.3 [0.25]
Weight	kg [lbs]	0.024 [0.052]	0.026 [0.058]	0.034 [0.074]
Pressure Range	bar [psi]	3-7 [40-100]		
Ingress Protection Class (IP)		IP 33 (RPM) / IP64 (RPMC)		
Displacement	cm ³ [in ³]	0.13 [0.008]	0.20 [0.012]	0.25 [0.015]
Temperature Range (Buna-N seals)	°C [°F]	-35°~80° [-30°~180°]		
Temperature Range (Viton® seals)	°C [°F]	-30°~120° [-20°~250°]		
Actuation (open/close)	sec	0.10		
Accuracy	mm [in]	±0.05 [±0.002]		
Repeatability	mm [in]	±0.03 [±0.001]		
Valve to Actuate		4-way, 2-position		

RPM-1M/RPMC-1M, RPM-2M/RPMC-2M

2-Jaw General Industrial Grippers | Dimensions

RPM-1M/RPMC-1M Dimensions

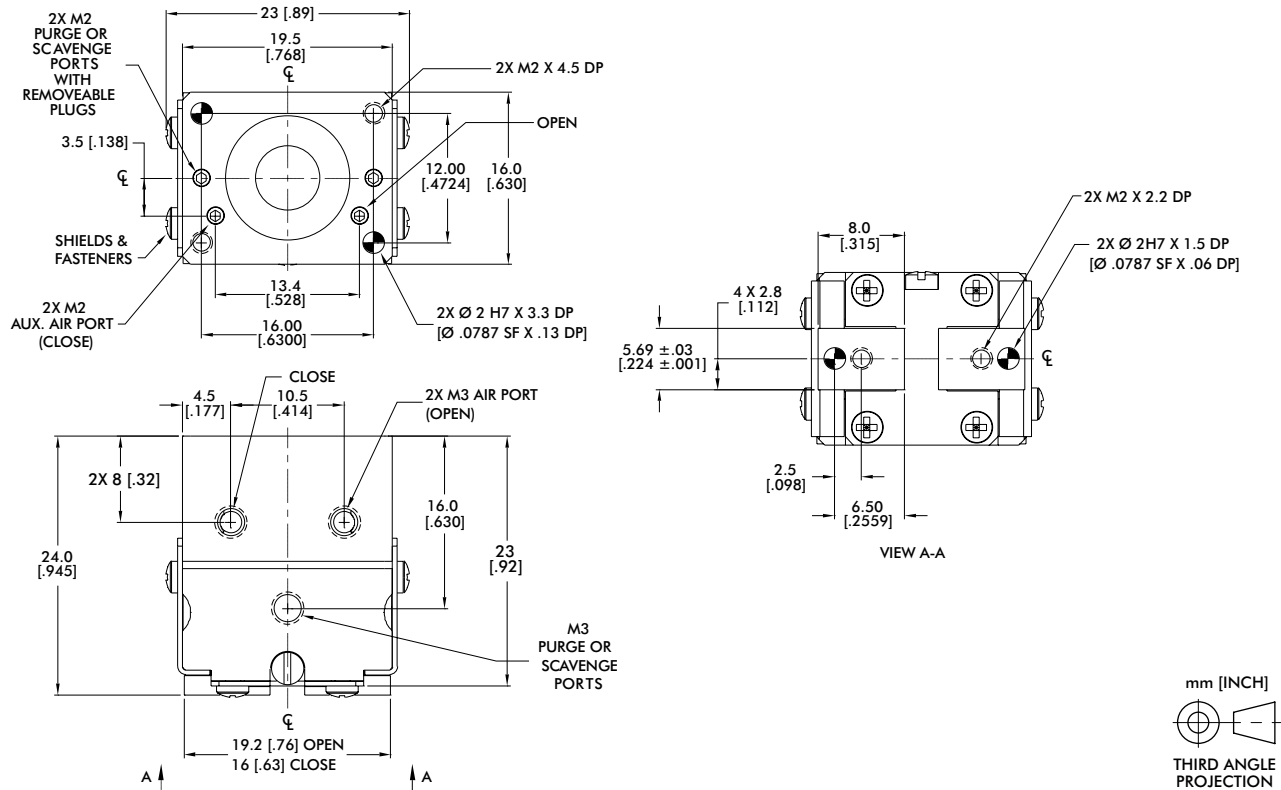

RPM-2M/RPMC-2M Dimensions

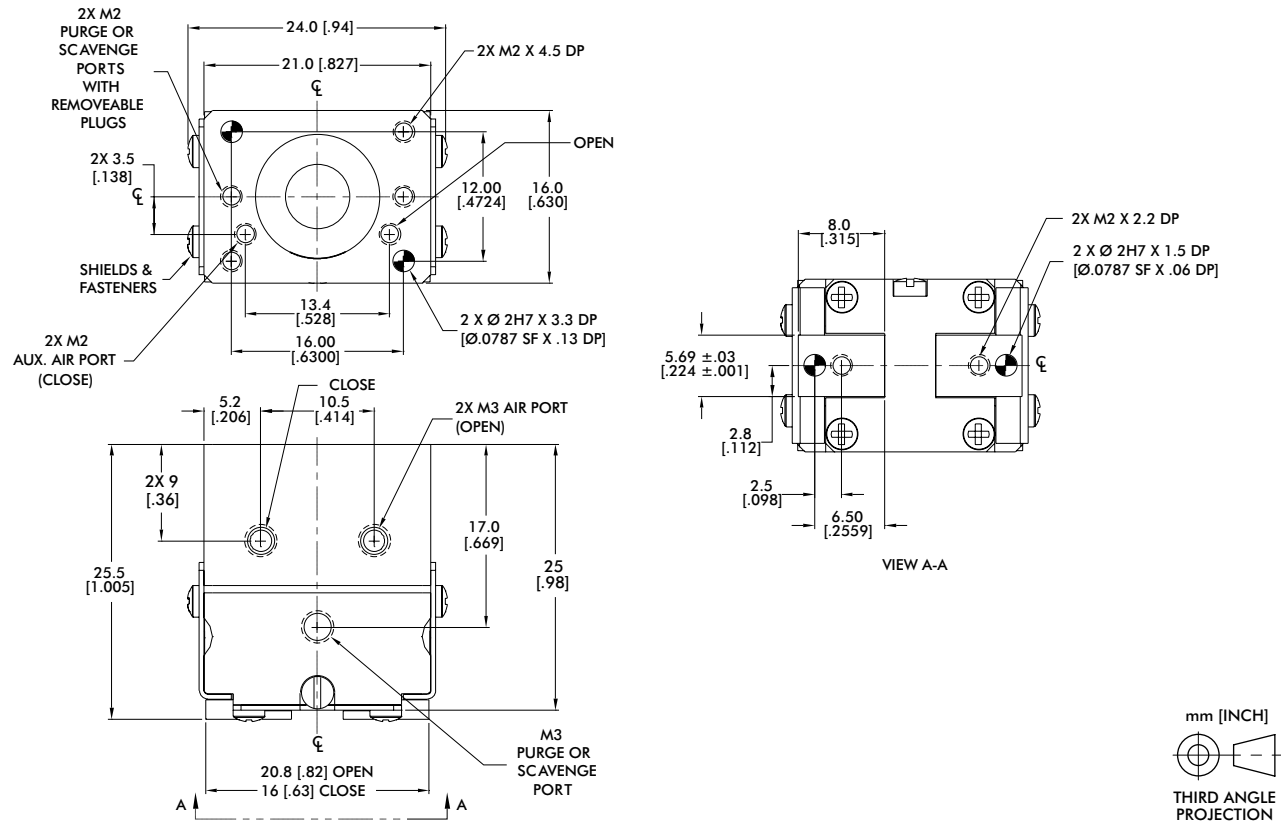

RPM-3M/RPMC-3M

2-Jaw General Industrial Grippers | Dimensions and Technical Specifications

RPM-3M/RPMC-3M Dimensions

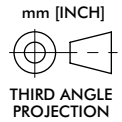
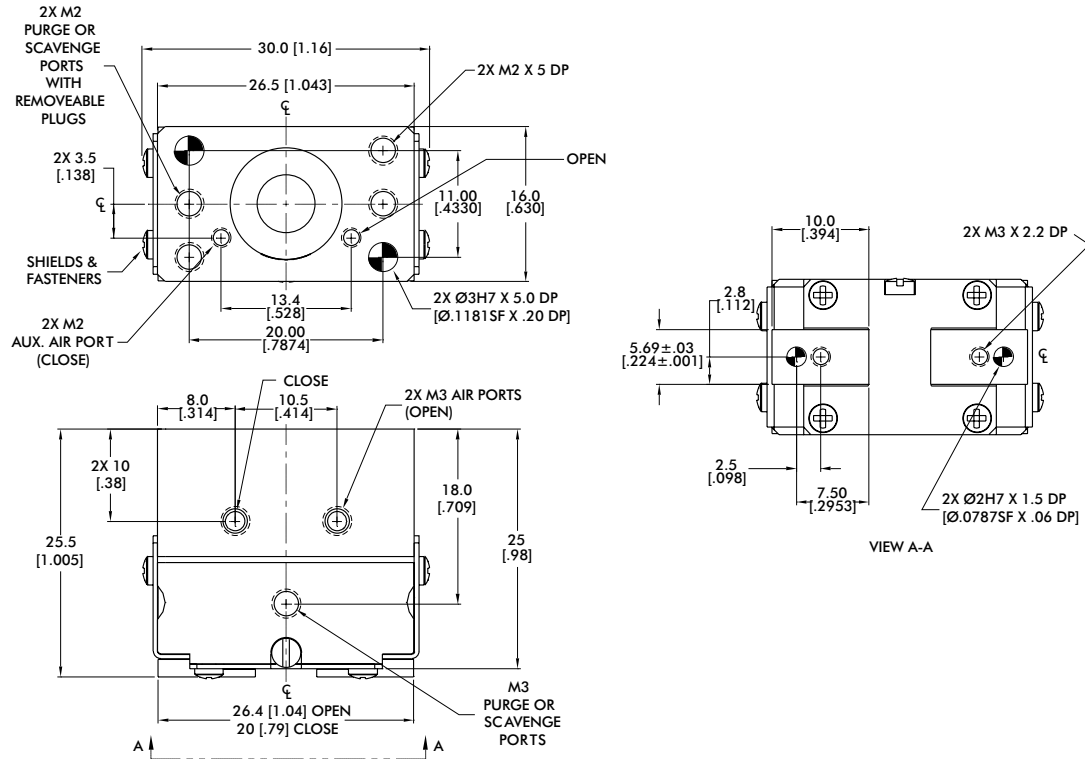

Loading Information

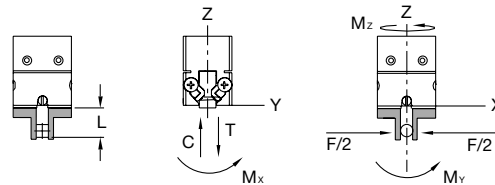
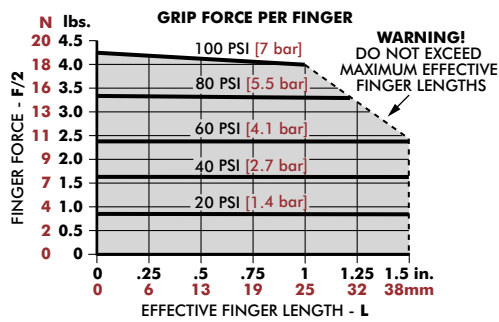

RPM	Static	Dynamic
Maximum Tensile T	89 N [20 lbs]	31 N [7 lbs]
Maximum Compressive C	89 N [20 lbs]	31 N [7 lbs]
Maximum Moment M_x	1 Nm [12 in-lbs]	0.5 Nm [4 in-lbs]
Maximum Moment M_y	2 Nm [15 in-lbs]	0.6 Nm [5 in-lbs]
Maximum Moment M_z	1 Nm [12 in-lbs]	0.5 Nm [4 in-lbs]

*Capacities are per set of jaws and are not simultaneous

RPS SERIES

2-Jaw General Industrial Parallel Grippers | Features and Benefits | How To Order

Features:

- Robust sealed design gripper
- Double wedge design for high impact applications
- Spring assist option for part retention in case of air pressure loss
- Inductive jaw location sensing
- Grip force range from 222N [50 lbs] to 2669N [600 lbs]
- Stroke Range from 6.4mm [0.25 in] to 31.8mm [1.25 in]

Applications:

- Automotive assembly
- Critical Part drop prevention applications
- General purpose spring assist gripping
- Packaging applications



U.S. Patent #5,125,708

How To Order

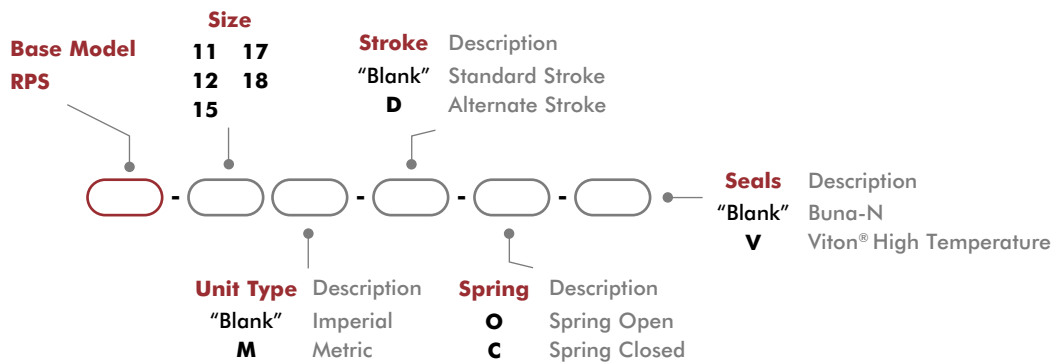

Accessories

Sensor Accessories	Model Numbers	Part Number	Qty/Unit
Sensor Mounting Kit for Imperial & Metric Units (mounts 2 sensors)	See Datasheet		1
NPN Inductive Sensor with Quick Disconnect*	11, 12, 15	OISN-019	1-2
PNP Inductive Sensor with Quick Disconnect*	11, 12, 15	OISP-019	1-2
NPN Inductive Sensor with Quick Disconnect*	17, 18	OISN-011	1-2
PNP Inductive Sensor with Quick Disconnect*	17, 18	OISP-011	1-2
Quick Disconnect 2 Meter Cable Length*	All Models	CABL-010	1-2
Quick Disconnect 5 Meter Cable Length*	All Models	CABL-013	1-2

Pneumatic Accessories	Model Numbers	Part Number	Qty/Unit
Fail Safe Valve (Imperial)	See Datasheet		1
Fail Safe Valve (Metric)	See Datasheet		1

*Sensor and cable sold separately.

2-Jaw General Industrial Parallel Grippers | Technical Specifications

Specifications	Units	11	11-D	12	12-D	15	15-D
Total Rated Grip Force F @ 100 psi [7 bar]	N [lbs]	222 [50]	378 [85]	267 [60]	400 [90]	400 [90]	110 [489]
Total Stroke	mm [in]	6.4 [0.25]	4 [0.16]	9.5 [0.38]	6 [0.24]	12.7 [0.50]	8 [0.31]
Weight	kg [lbs]	0.16 [0.36]		0.34 [0.76]		0.65 [1.44]	
Pressure Range	bar [psi]	3.4-7 [50-100]					
Ingress Protection Class (IP)		IP43					
Displacement	cm ³ [in ³]	1.6 [0.098]		2.5 [0.150]		4.9 [0.300]	
Temperature Range (Buna-N seals)	°C [°F]	-35°~80° [-30°~180°]					
Temperature Range (Viton® seals)	°C [°F]	-30°~150° [-20°~300°]					
Actuation	sec	0.15				0.17	
Accuracy	mm [in]	±0.05 [±0.002]					
Repeatability	mm [in]	±0.03 [±0.001]					
Valve to Required Actuate Single Acting		3-way, 2-position					
Valve to Required Actuate Double Acting		4-way, 2-position					

Specifications	Units	17	17-D	18	18-D
Total Rated Grip Force F @ 100 psi [7 bar]	N [lbs]	1334 [300]	180 [800]	2669 [600]	380 [1690]
Total Stroke	mm [in]	19.1 [0.75]	28 [1.10]	31.8 [1.25]	43 [1.70]
Weight	kg [lbs]	1.4 [3.00]		5.0 [11.02]	
Pressure Range	bar [psi]	3-7 [40-100]			
Ingress Protection Class (IP)		IP43			
Displacement	cm ³ [in ³]	22.9 [1.400]		72.1 [4.400]	
Temperature Range (Buna-N seals)	°C [°F]	-35°~80° [-30°~180°]			
Temperature Range (Viton® seals)	°C [°F]	-30°~150° [-20°~300°]			
Actuation	sec	0.31		0.51	
Accuracy	mm [in]	±0.08 [±0.003]			
Repeatability	mm [in]	±0.03 [±0.001]			
Valve to Required Actuate Single Acting		3-way, 2-position			
Valve to Required Actuate Double Acting		4-way, 2-position			

RPS-11

2-Jaw General Industrial Parallel Grippers | Dimensions and Technical Specifications

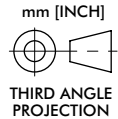
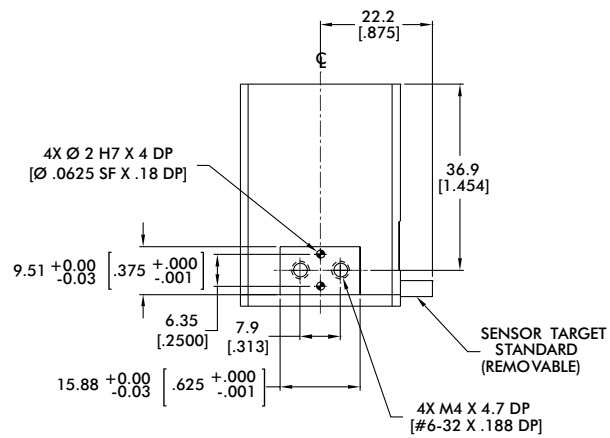
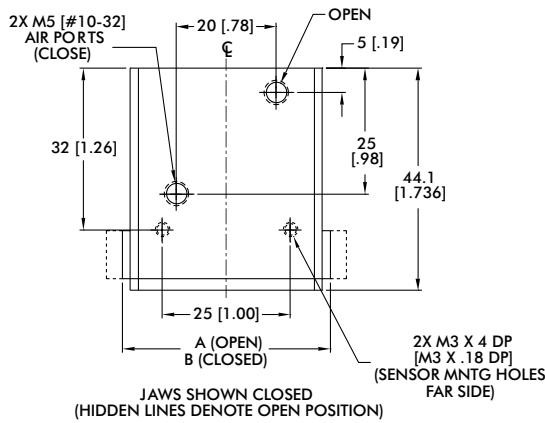
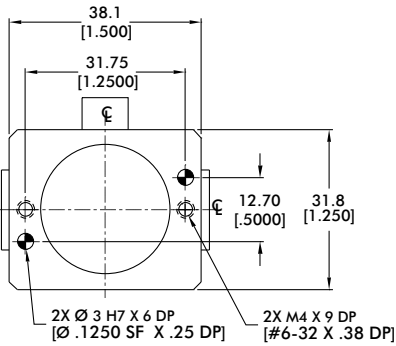

Sensor Accessories	RPS-11
Inductive Sensor Mounting Kit (mounts 2 sensors)	OSMK-003

Seal Repair Kits	RPS-11
Buna-N Seal Repair Kit	SLKT-036
Viton® Seal Repair Kit	SLKT-036V

Pneumatic Accessories	RPS-11
Fail Safe Valve (Imperial)	OFSV-001
Fail Safe Valve (Metric)	OFSV-004

Model	A	B
RPS-11	48 [1.88]	41 [1.63]
RPS-11-D	45 [1.79]	

Loading Information

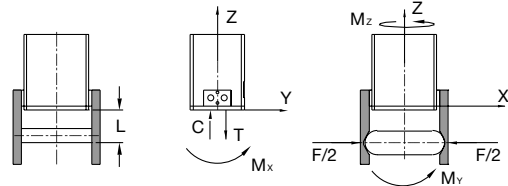
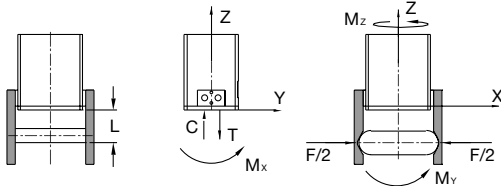
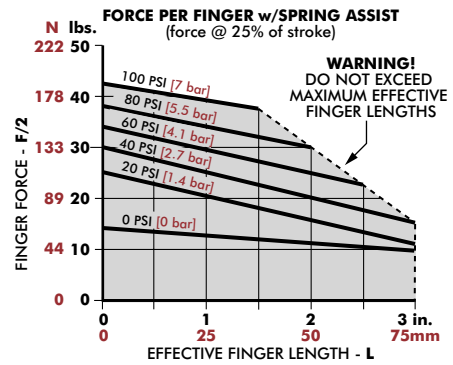
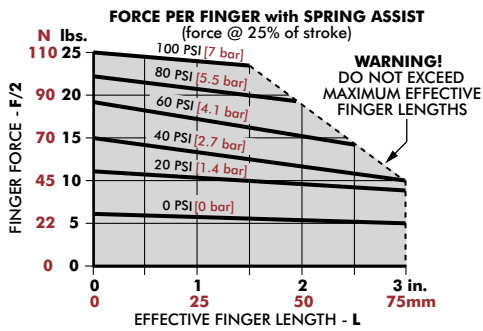

RPS-11	Static	Dynamic
Maximum Tensile T	445 N [100 lbs]	111 N [25 lbs]
Maximum Compressive C	890 N [200 lbs]	111 N [25 lbs]
Maximum Moment M_x	11 Nm [100 in-lbs]	3 Nm [25 in-lbs]
Maximum Moment M_y	11 Nm [100 in-lbs]	3 Nm [25 in-lbs]
Maximum Moment M_z	11 Nm [100 in-lbs]	3 Nm [25 in-lbs]

*Capacities are per set of jaws and are not simultaneous

RPS-11-D	Static	Dynamic
Maximum Tensile T	445 N [100 lbs]	111 N [25 lbs]
Maximum Compressive C	890 N [200 lbs]	111 N [25 lbs]
Maximum Moment M_x	11 Nm [100 in-lbs]	3 Nm [25 in-lbs]
Maximum Moment M_y	11 Nm [100 in-lbs]	3 Nm [25 in-lbs]
Maximum Moment M_z	11 Nm [100 in-lbs]	3 Nm [25 in-lbs]

*Capacities are per set of jaws and are not simultaneous

2-Jaw General Industrial Parallel Grippers | Dimensions and Technical Specifications

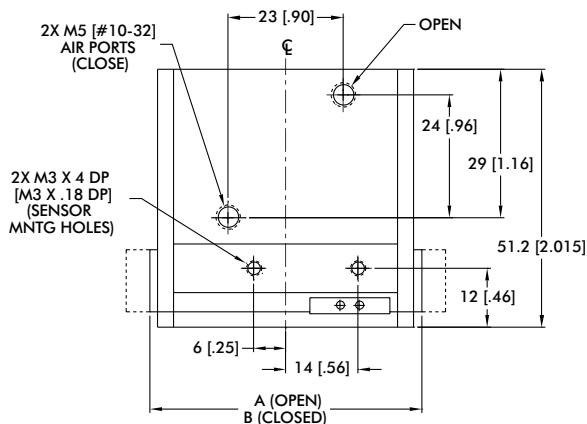
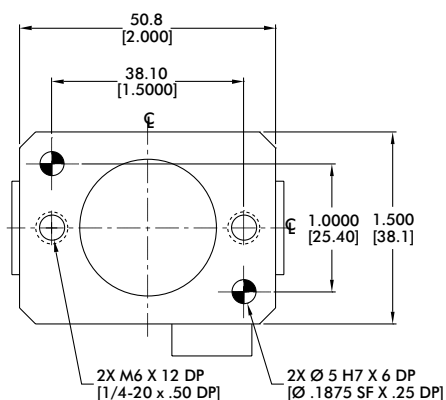

JAWS SHOWN IN CLOSED POSITION
(HIDDEN LINES DENOTE OPEN POSITION)

Sensor Accessories	RPS-12
Inductive Sensor Mounting Kit (mounts 2 sensors)	OSMK-003

Seal Repair Kits	RPS-12
Buna-N Seal Repair Kit	SLKT-040
Viton® Seal Repair Kit	SLKT-040V

Pneumatic Accessories	RPS-12
Fail Safe Valve (Imperial)	OFSV-001
Fail Safe Valve (Metric)	OFSV-004

Model	A	B
RPS-12	63 [2.50]	54 [2.13]
RPS-12-D	60 [2.37]	

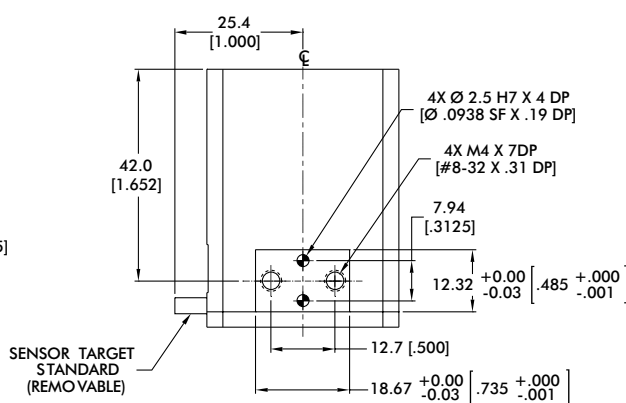
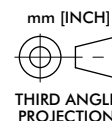

Loading Information

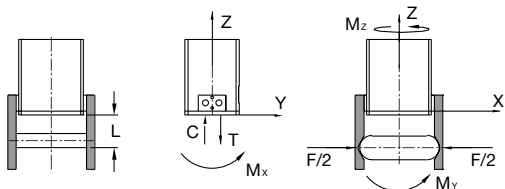
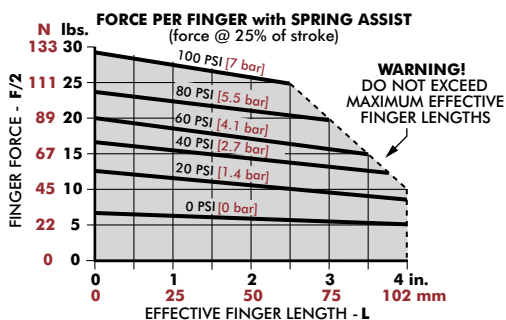

RPS-12	Static	Dynamic
Maximum Tensile T	890 N [200 lbs]	222 N [50 lbs]
Maximum Compressive C	1779 N [400 lbs]	222 N [50 lbs]
Maximum Moment M_x	17 Nm [150 in-lbs]	6 Nm [50 in-lbs]
Maximum Moment M_y	17 Nm [150 in-lbs]	6 Nm [50 in-lbs]
Maximum Moment M_z	17 Nm [150 in-lbs]	6 Nm [50 in-lbs]

¹Capacities are per set of jaws and are not simultaneous

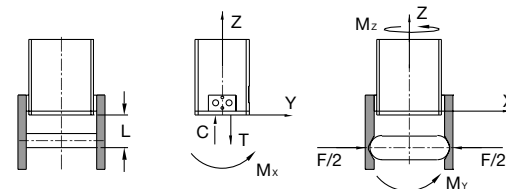
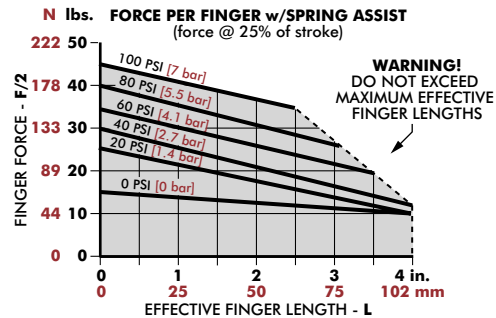

RPS-12-D	Static	Dynamic
Maximum Tensile T	890 N [200 lbs]	222 N [50 lbs]
Maximum Compressive C	1779 N [400 lbs]	222 N [50 lbs]
Maximum Moment M_x	17 Nm [150 in-lbs]	6 Nm [50 in-lbs]
Maximum Moment M_y	17 Nm [150 in-lbs]	6 Nm [50 in-lbs]
Maximum Moment M_z	17 Nm [150 in-lbs]	6 Nm [50 in-lbs]

¹Capacities are per set of jaws and are not simultaneous

RPS-15

2-Jaw General Industrial Parallel Grippers | Dimensions and Technical Specifications

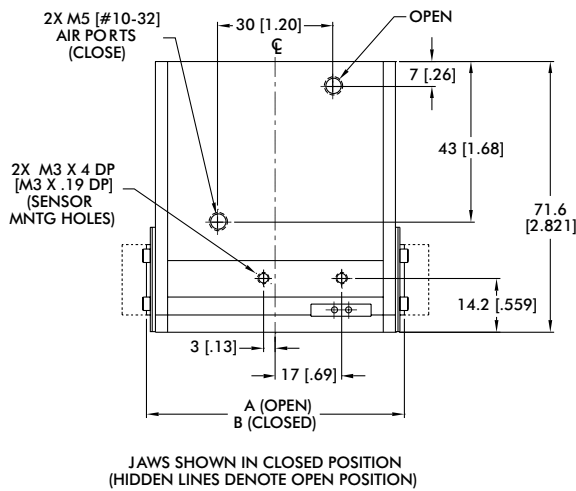
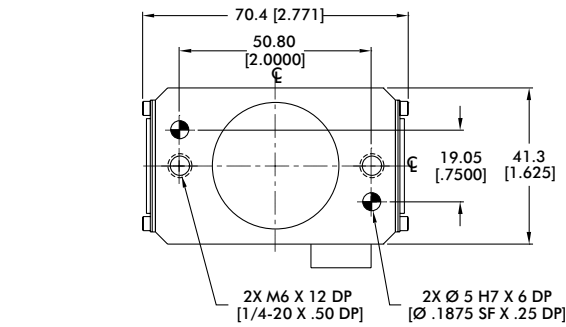

JAWS SHOWN IN CLOSED POSITION
(HIDDEN LINES DENOTE OPEN POSITION)

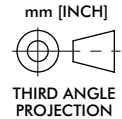
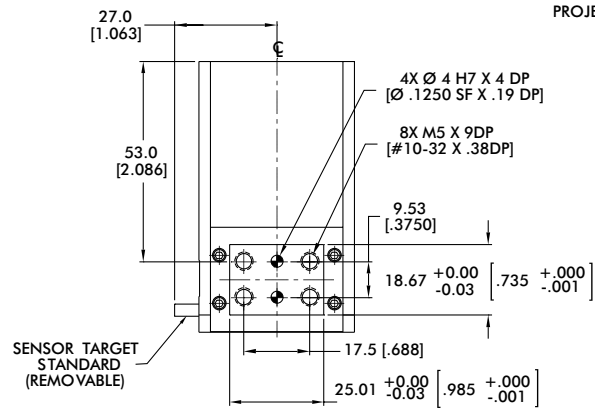

Sensor Accessories	RPS-15
Inductive Sensor Mounting Kit (mounts 2 sensors)	OSMK-003

Seal Repair Kits	RPS-15
Buna-N Seal Repair Kit	SLKT-041
Viton® Seal Repair Kit	SLKT-041V

Pneumatic Accessories	RPS-15
Fail Safe Valve (Imperial)	OFSV-001
Fail Safe Valve (Metric)	OFSV-004

Model	A	B
RPS-15	81 [3.19]	68 [2.69]
RPS-15-D	76 [3.00]	

Loading Information

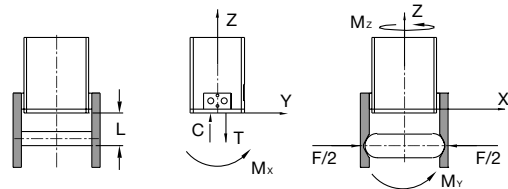
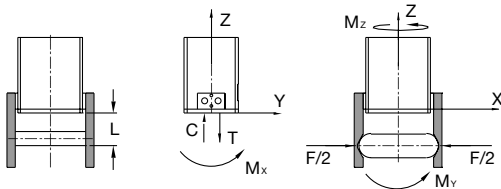
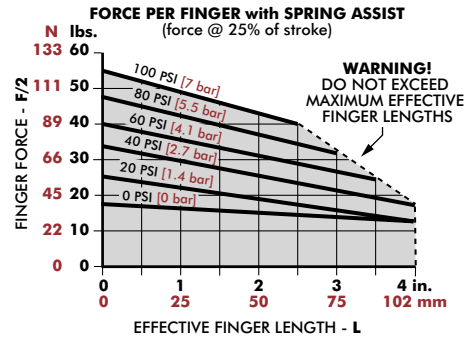
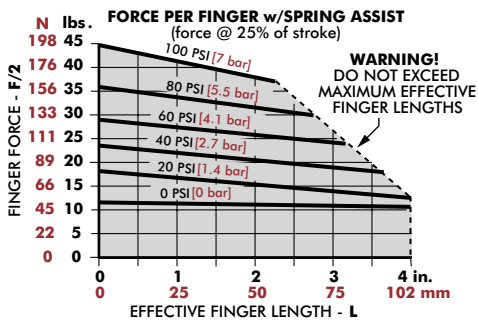

RPS-15	Static	Dynamic
Maximum Tensile T	1779 N [400 lbs]	445 N [100 lbs]
Maximum Compressive C	3336 N [750 lbs]	445 N [100 lbs]
Maximum Moment M_x	34 Nm [300 in-lbs]	11 Nm [100 in-lbs]
Maximum Moment M_y	34 Nm [300 in-lbs]	11 Nm [100 in-lbs]
Maximum Moment M_z	34 Nm [300 in-lbs]	11 Nm [100 in-lbs]

*Capacities are per set of jaws and are not simultaneous

RPS-15-D	Static	Dynamic
Maximum Tensile T	1779 N [400 lbs]	445 N [100 lbs]
Maximum Compressive C	3336 N [750 lbs]	445 N [100 lbs]
Maximum Moment M_x	34 Nm [300 in-lbs]	11 Nm [100 in-lbs]
Maximum Moment M_y	34 Nm [300 in-lbs]	11 Nm [100 in-lbs]
Maximum Moment M_z	34 Nm [300 in-lbs]	11 Nm [100 in-lbs]

*Capacities are per set of jaws and are not simultaneous

2-Jaw General Industrial Parallel Grippers | Dimensions and Technical Specifications

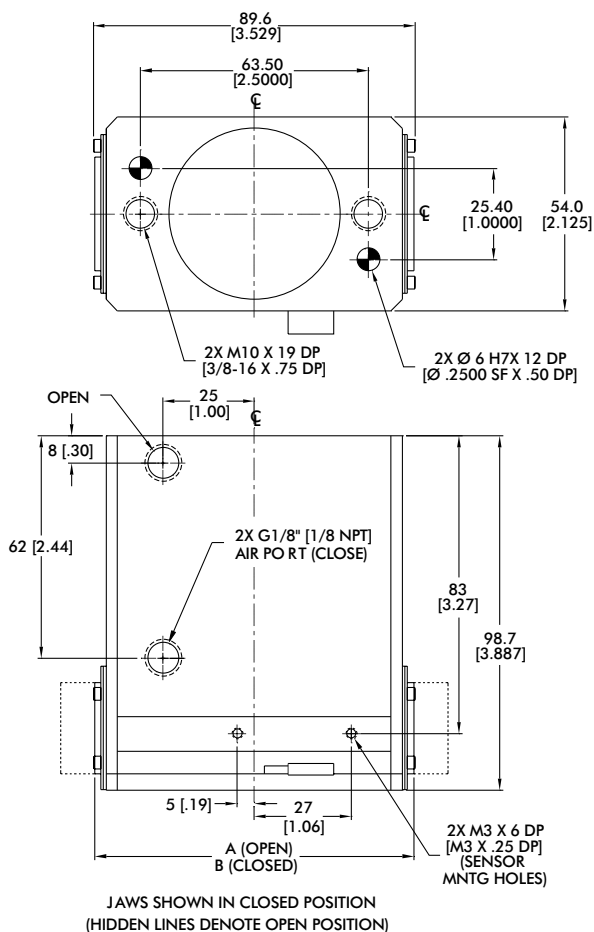

Sensor Accessories	RPS-17
Inductive Sensor Mounting Kit (mounts 2 sensors)	OSMK-072

Seal Repair Kits	RPS-17
Buna-N Seal Repair Kit	SLKT-042
Viton® Seal Repair Kit	SLKT-042V

Pneumatic Accessories	RPS-17
Fail Safe Valve (Imperial)	OFSV-002
Fail Safe Valve (Metric)	OFSV-005

Model	A	B
RPS-17	107 [4.25]	
RPS-17-D	117 [4.60]	89 [3.50]

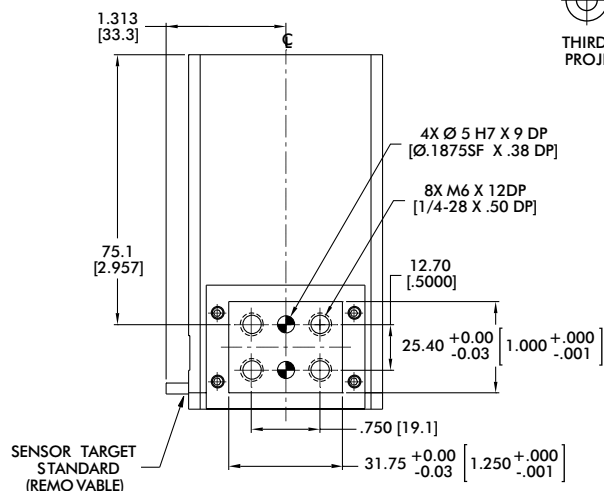
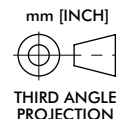

Loading Information

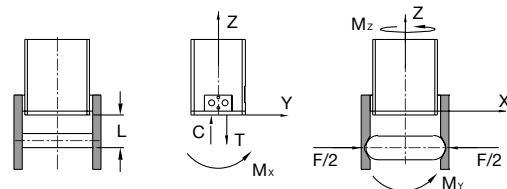
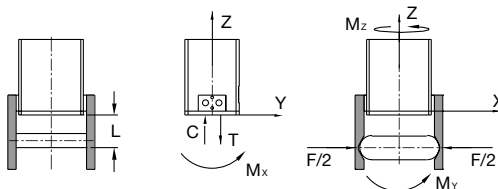
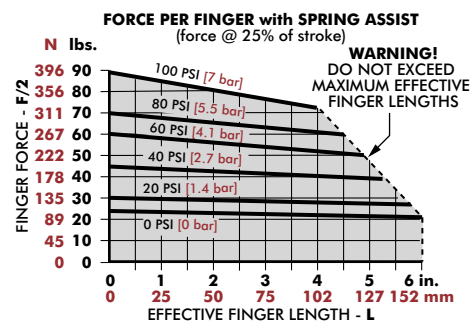
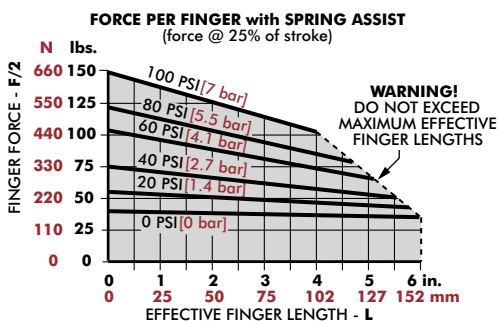

RPS-17	Static	Dynamic
Maximum Tensile T	3336 N [750 lbs]	890 N [200 lbs]
Maximum Compressive C	6672 N [1500 lbs]	890 N [200 lbs]
Maximum Moment M_x	85 Nm [750 in-lbs]	28 Nm [250 in-lbs]
Maximum Moment M_y	85 Nm [750 in-lbs]	28 Nm [250 in-lbs]
Maximum Moment M_z	85 Nm [750 in-lbs]	28 Nm [250 in-lbs]

¹Capacities are per set of jaws and are not simultaneous

RPS-17-D	Static	Dynamic
Maximum Tensile T	3336 N [750 lbs]	890 N [200 lbs]
Maximum Compressive C	6672 N [1500 lbs]	890 N [200 lbs]
Maximum Moment M_x	85 Nm [750 in-lbs]	28 Nm [250 in-lbs]
Maximum Moment M_y	85 Nm [750 in-lbs]	28 Nm [250 in-lbs]
Maximum Moment M_z	85 Nm [750 in-lbs]	28 Nm [250 in-lbs]

¹Capacities are per set of jaws and are not simultaneous

RPS-18

2-Jaw General Industrial Parallel Grippers | Dimensions and Technical Specifications

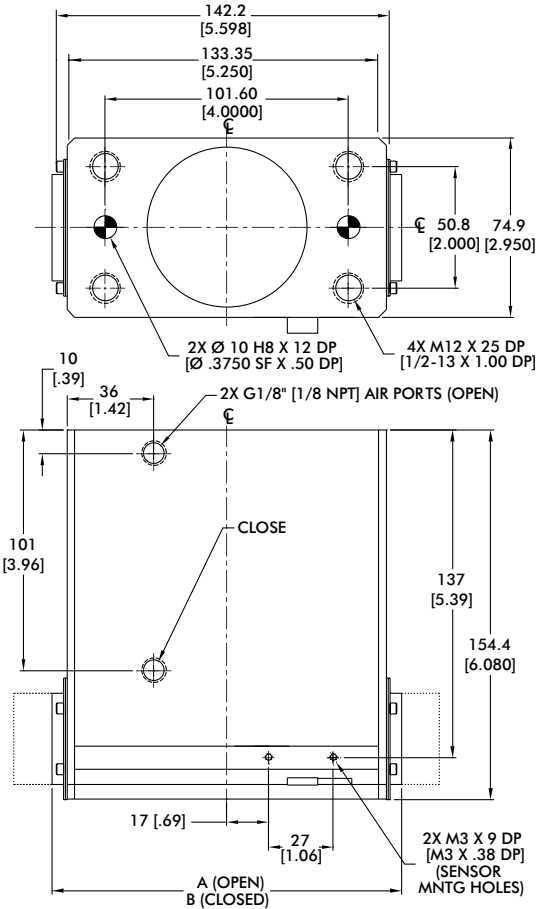

JA WS SHOWN IN CLOSED POSITION
(HIDDEN LINES DENOTE OPEN POSITION)

Sensor Accessories	RPS-18
Inductive Sensor Mounting Kit (mounts 2 sensors)	OSMK-072

Seal Repair Kits	RPS-18
Buna-N Seal Repair Kit	SLKT-043
Viton® Seal Repair Kit	SLKT-043V

Pneumatic Accessories	RPS-18
Fail Safe Valve (Imperial)	OFSV-002
Fail Safe Valve (Metric)	OFSV-005

Model	A	B
RPS-18	177 [7.00]	146 [5.75]
RPS-18-D	190 [7.45]	

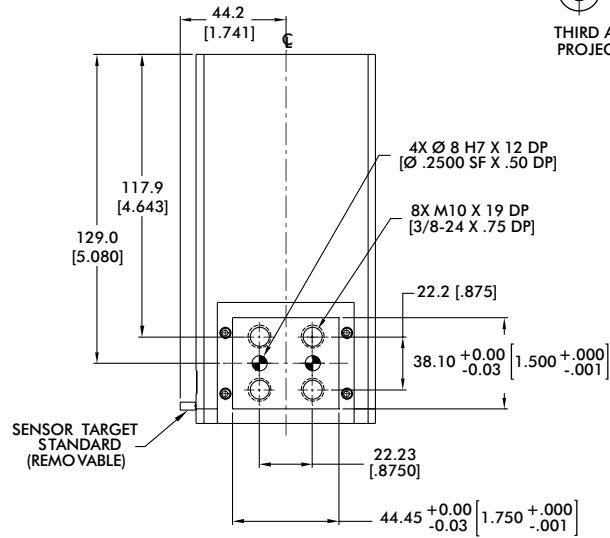
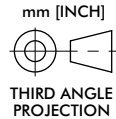

Loading Information

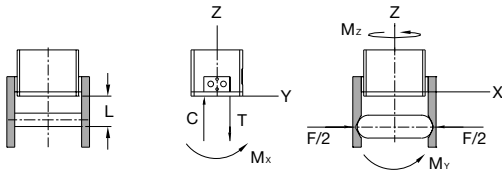
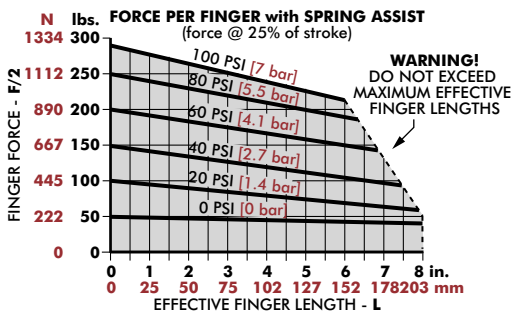

RPS-18	Static	Dynamic
Maximum Tensile T	6672 N [1500 lbs]	2224 N [500 lbs]
Maximum Compressive C	13345 N [3000 lbs]	2224 N [500 lbs]
Maximum Moment M_x	170 Nm [1500 in-lbs]	57 Nm [500 in-lbs]
Maximum Moment M_y	170 Nm [1500 in-lbs]	57 Nm [500 in-lbs]
Maximum Moment M_z	170 Nm [1500 in-lbs]	57 Nm [500 in-lbs]

*Capacities are per set of jaws and are not simultaneous

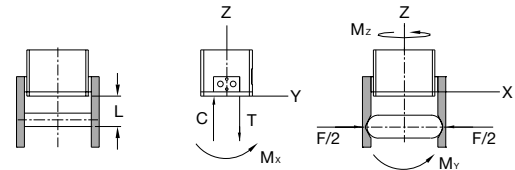
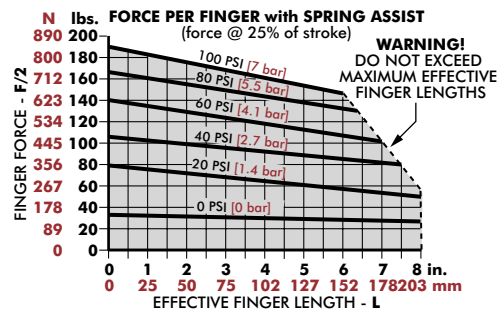





RPS-18-D	Static	Dynamic
Maximum Tensile T	6672 N [1500 lbs]	2224 N [500 lbs]
Maximum Compressive C	13345 N [3000 lbs]	2224 N [500 lbs]
Maximum Moment M_x	170 Nm [1500 in-lbs]	57 Nm [500 in-lbs]
Maximum Moment M_y	170 Nm [1500 in-lbs]	57 Nm [500 in-lbs]
Maximum Moment M_z	170 Nm [1500 in-lbs]	57 Nm [500 in-lbs]

*Capacities are per set of jaws and are not simultaneous

PNEUMATIC HEAVY DUTY GRIPPERS

Product Overview

	Model	Stroke mm [in]	Grip Force N [lbf]	Operating Environment	Special Features	Page GR-HDP-#
DPW		19.05-63.5 [0.75-2.5]	222-801 [50-180]	IP66, Harsh Environment	High Impact Loading Gripper. Long Finger Lengths. Ideal for Long or Wide Part Handling. <i>DIRECTCONNECT</i>	3
RPB		101.6-203.2 [4.0-8.0]	2669 [600]	IP55 Using Purge Port & Shield Option, Harsh Environment	Gantry Systems, Heavy Payloads. Long Stroke. High Precision. Long Finger Lengths.	9
RPR		150-350 [5.9-13.78]	3520 [800]	IP65, Harsh Environment	Gantry Systems, Heavy Payloads. Long Finger Lengths. Rod Lock option	13
RPW		19.1-114.3 [0.75-4.5]	222-2091 [50-470]	IP54, Harsh Environment	High Impact Loading Gripper. Long Finger Lengths. Ideal for Long or Wide Part Handling.	17

PNEUMATIC HEAVY DUTY GRIPPERS

2-Jaw Heavy-Duty Parallel Grippers | DIRECTCONNECT™ Mounting Compatibility Chart

Modular DIRECTCONNECT Mounting Style Examples:

Products can be mounted in multiple positions. Refer to datasheet for complete info.

Slide to Gripper

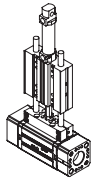

DLT Thruster Slide to DPW Parallel Gripper

Slide to Gripper

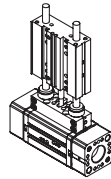

DLT Thruster Slide to DPW Parallel Gripper

Slide to Gripper

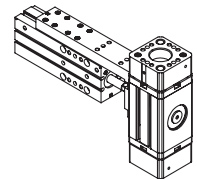

DLM Thruster Slide to DPW Parallel Gripper

DIRECTCONNECT™

Mounting Compatibility Chart

DESTACO's DIRECTCONNECT™ technology, allows all components of the system—grippers, rotaries and slides—to be mounted together directly. Look for matching icons on product datasheets for mounting compatibility.

Note: The numbers in the cell represent the metric screw size and basic mounting pattern.

S=Square, R=Rectangle. ie; 5S = M5 Screw with square mounting pattern.

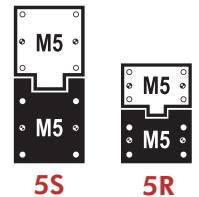

Catalog Models		Grippers	
		DPW-250	DPW-375, 500
Base Slides	DLB-06,08	3R	
	DLB-10,12,16		5R
	DLB-20,25		
Thruster Slides	DLT-06,08	3R	
	DLT-10,12,16	3R	5R
	DLT-20,25		5R
	DLM-07	3R	
	DLM-9,12	3R	5R

DPW SERIES

2-Jaw Heavy-Duty Parallel Grippers | Features and Benefits | How To Order

Features:

- Robust wide body gripper with DIRECTCONNECT mounting
- Grip force ranges from 222N thru 800N
- Strokes range from 19mm thru 63.5mm
- Rack and pinion design for smooth operation
- Jaws well supported to grip large and wide parts
- Multiple air ports where top ports can be manifolded
- Shaft wiper seals for harsh environments
- Optional non-synchronous jaw operation

Applications:

- Wide part gripping
- Gantry systems
- Harsh gripping environment
- Long finger applications

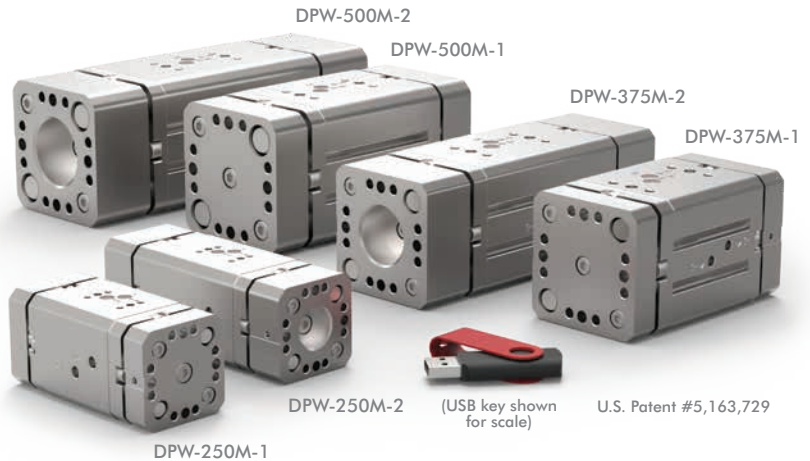

How To Order

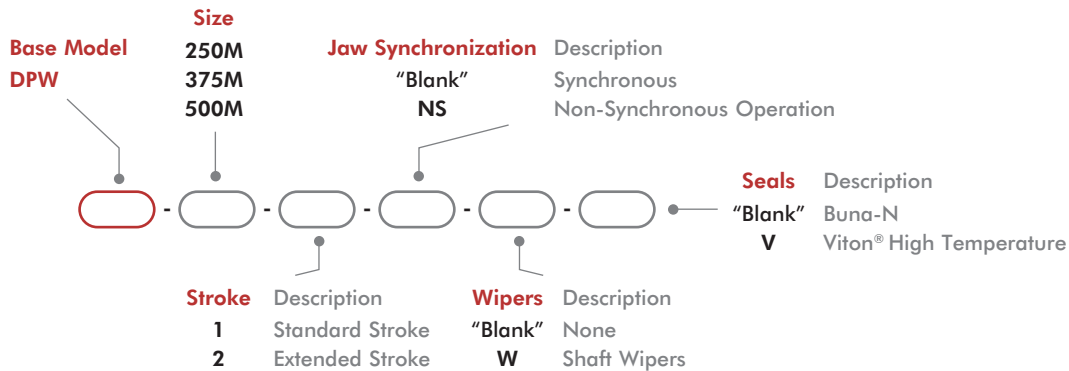

Accessories

Sensor Accessories	Model Numbers	Part Number	Qty/Unit
PNP Magneto Resistive Sensor Short Barrel (with Qk. Disc.)*	All Models	OHSP-017	1-4†
NPN Magneto Resistive Sensor Short Barrel (with Qk. Disc.)*	All Models	OHSN-017	1-4†
PNP Magneto Resistive Sensor 90° Barrel (with Qk. Disc.)*	All Models	OHSP-011	1-4†
NPN Magneto Resistive Sensor 90° Barrel (with Qk. Disc.)*	All Models	OHSN-011	1-4†
PNP Inductive Sensor 3mm with Quick Disconnect*	All Models	OISP-019	1-2
NPN Inductive Sensor 3mm with Quick Disconnect.*	All Models	OISN-019	1-2
PNP Inductive Sensor 4mm with Quick Disconnect*	375M, 500M	OISP-014	1-2
NPN Inductive Sensor 4mm with Quick Disconnect*	375M, 500M	OISN-014	1-2
Quick Disconnect 2 Meter Cable Length*	All Models	CABL-010	1-4†
Quick Disconnect 5 Meter Cable Length*	All Models	CABL-013	1-4†

Pneumatic Accessories	Model Numbers	Part Number	Qty/Unit
Fail Safe Valve M5	All Models	OFSV-004	1
Adjustable Flow Control	All Models	VLVF-008	1-2

* Sensor and cable sold separately. † Except 250-1, 250-2, 1-2 only.

2-Jaw Heavy-Duty Parallel Grippers | Technical Specifications

Specifications	Units	250M-1	250M-2	375M-1	375-2
Total Rated Grip Force F @ 7 bar [100 psi]	N [lbf]	222 [50]		445 [100]	
Total Stroke	mm [in]	19.1 [0.75]	31.8 [1.25]	25.4 [1.00]	50.8 [2.00]
Weight	kg [lb]	0.30 [0.66]	0.39 [0.86]	0.81 [1.80]	1.20 [2.66]
Pressure Range	bar [psi]	1.5-7 [20-100]			
Ingress Protection Class (IP)		IP66			
Displacement	cm ³ [in ³]	3.8 [0.023]	6.3 [0.383]	11.3 [0.690]	22.6 [1.382]
Temperature Range (Buna-N seals)	°C [°F]	-35°~80° [-30°~180°]			
Temperature Range (Viton® seals)	°C [°F]	-30°~150° [-20°~300°]			
Actuation	sec	0.12	0.14	0.16	0.20
Accuracy	mm [in]	±0.08 [±0.003]			
Repeatability	mm [in]	±0.03 [±0.001]			
Valve to Actuate Double Acting		4-way, 2-position			

Specifications	Units	500M-1	500M-2
Total Rated Grip Force F @ 7 bar [100 psi]	N [lbf]	800 [180]	
Total Stroke	mm [in]	38.1 [1.50]	63.5 [2.50]
Weight	kg [lb]	1.48 [3.27]	2.0 [4.39]
Pressure Range	bar [psi]	1.5-7 [20-100]	
Ingress Protection Class (IP)		IP66	
Displacement	cm ³ [in ³]	30.2 [1.841]	50.3 [3.068]
Temperature Range (Buna-N seals)	°C [°F]	-35°~80° [-30°~180°]	
Temperature Range (Viton® seals)	°C [°F]	-30°~150° [-20°~300°]	
Actuation	sec	0.20	0.28
Accuracy	mm [in]	±0.08 [±0.003]	
Repeatability	mm [in]	±0.03 [±0.001]	
Valve to Actuate Double Acting		4-way, 2-position	

2-Jaw Heavy-Duty Parallel Grippers | Dimensions and Technical Specifications

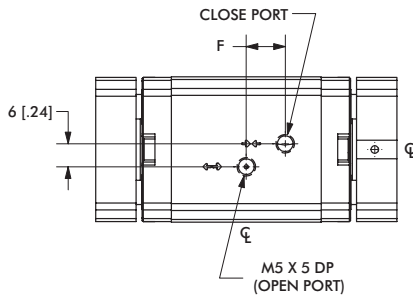
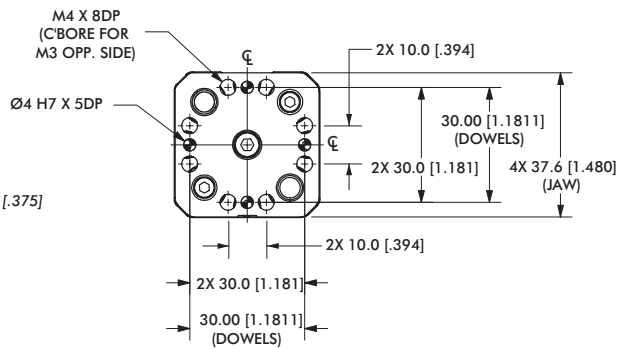
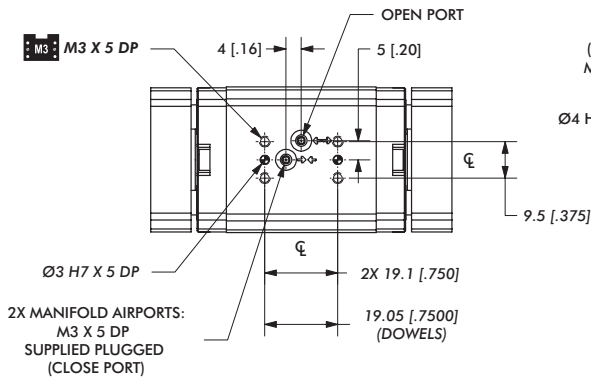
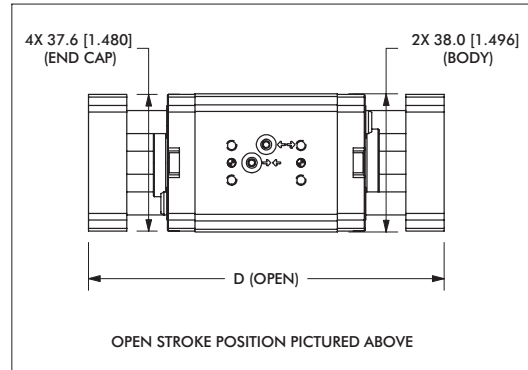
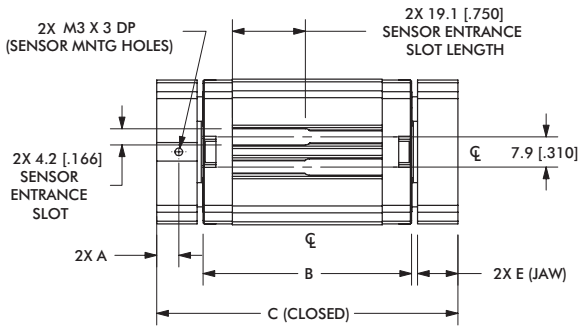

Model	A	B	C	D	E	F
DPW-250M-1	5.8 [0.227]	54.4 [2.140]	79 [3.09]	98 [3.85]	10.5 [0.414]	10 [0.40]
DPW-250M-2	7.3 [0.289]	67.1 [2.640]	104 [4.09]	136 [5.35]	16.9 [0.664]	12 [0.47]

Sensor Accessories	250M
Inductive Sensor Mtg Kit (3mm or 4mm)	OSMK-116

Seal Repair Kits	250M
Buna-N Seal Repair Kit	SLKT-337
Viton® Seal Repair Kit	SLKT-337V
Viton® Manifold Seal Kit	SLKT-197V
Shaft Wiper Seal Kit	SLKT-338

Loading Information

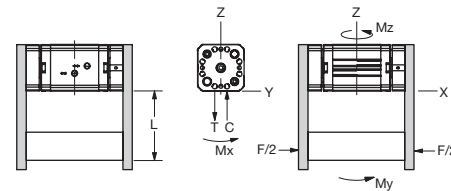
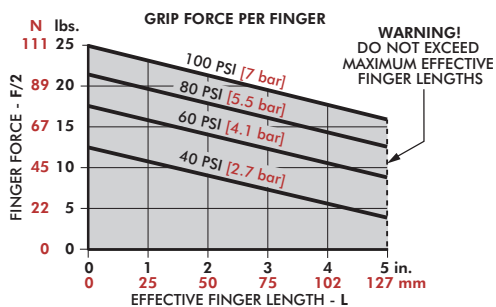

DPW-250M	Static	Dynamic
Maximum Tensile T	267 N [60 lbs]	53 N [12 lbs]
Maximum Compressive C	267 N [60 lbs]	53 N [12 lbs]
Maximum Moment M_x	14 Nm [120 in-lbs]	3 Nm [24 in-lbs]
Maximum Moment M_y	20 Nm [180 in-lbs]	4 Nm [36 in-lbs]
Maximum Moment M_z	14 Nm [120 in-lbs]	3 Nm [24 in-lbs]

*Capacities are per set of jaws and are not simultaneous

2-Jaw Heavy-Duty Parallel Grippers | Dimensions and Technical Specifications

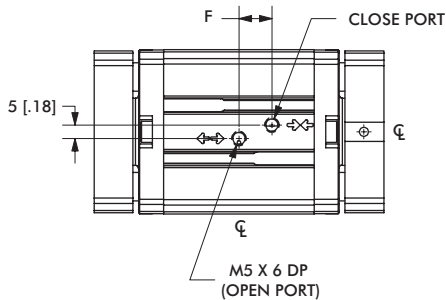
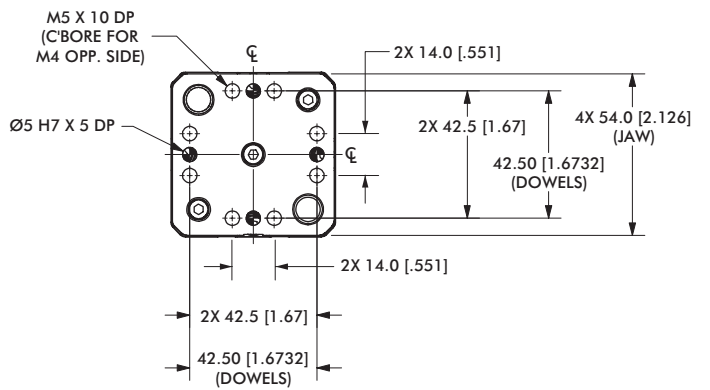
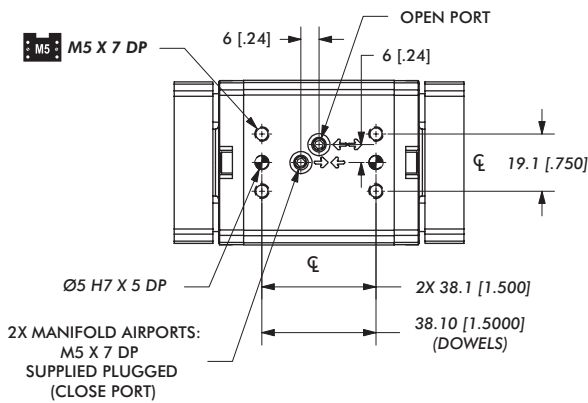
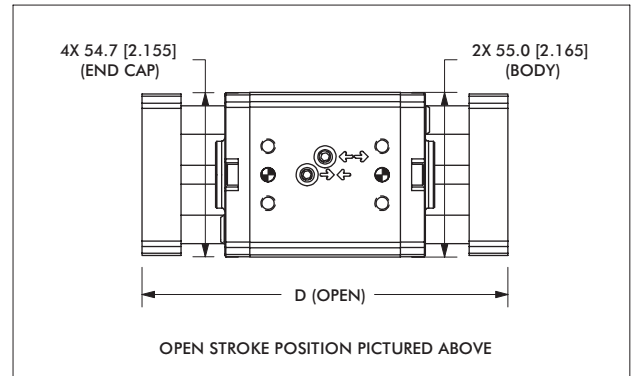
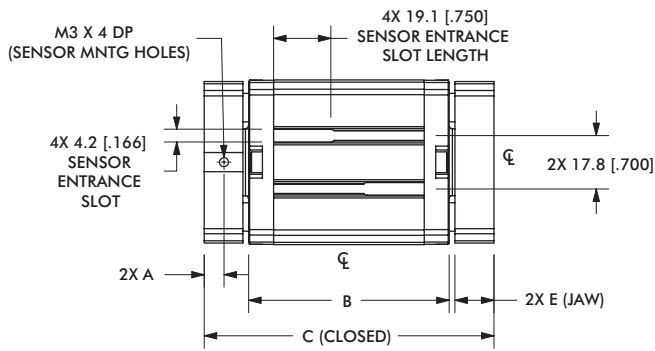

Model	A	B	C	D	E	F
DPW-375M-1	6.7 [0.262]	67.1 [2.640]	97 [3.81]	122 [4.81]	13.0 [0.512]	11 [0.43]
DPW-375M-2	11.7 [0.462]	92.5 [3.640]	147 [5.81]	198 [7.81]	25.7 [1.012]	12 [0.47]

Sensor Accessories	375M
Inductive Sensor Mtg Kit (3mm or 4mm)	OSMK-117

Seal Repair Kits	375M
Buna-N Seal Repair Kit	SLKT-339
Viton® Seal Repair Kit	SLKT-339V
Viton® Manifold Seal Kit	SLKT-199V
Shaft Wiper Seal Kit	SLKT-340

Loading Information

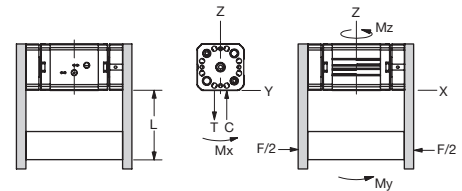
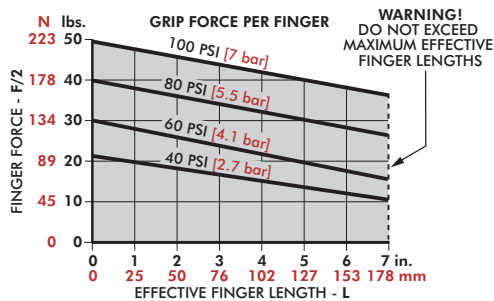

DPW-375M	Static	Dynamic
Maximum Tensile T	534 N [120 lbs]	107 N [24 lbs]
Maximum Compressive C	534 N [120 lbs]	107 N [24 lbs]
Maximum Moment M _x	24 Nm [210 in-lbs]	5 Nm [42 in-lbs]
Maximum Moment M _y	34 Nm [300 in-lbs]	7 Nm [60 in-lbs]
Maximum Moment M _z	24 Nm [210 in-lbs]	5 Nm [42 in-lbs]

*Capacities are per set of jaws and are not simultaneous

DPW-500M

2-Jaw Heavy-Duty Parallel Grippers | Dimensions and Technical Specifications

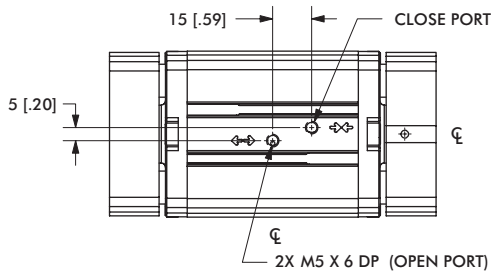
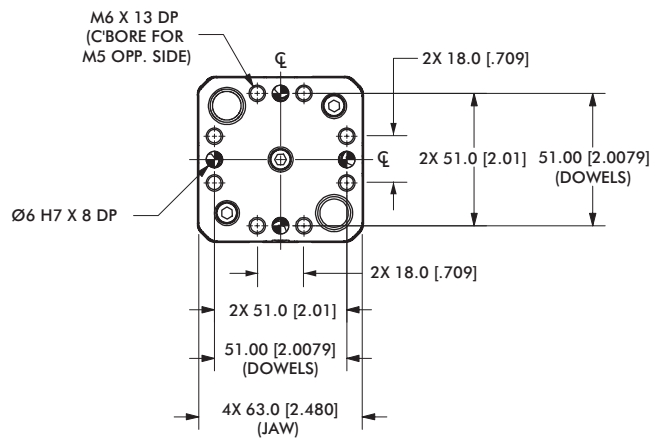
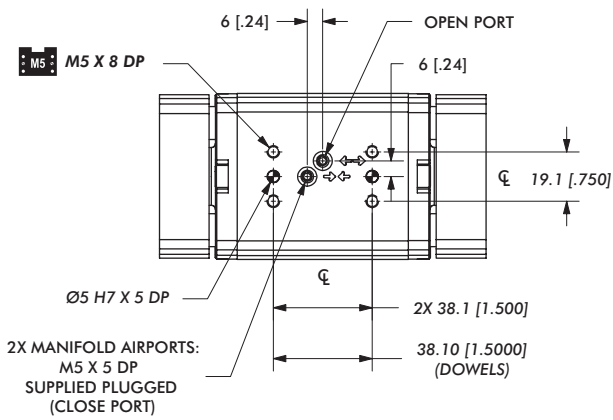
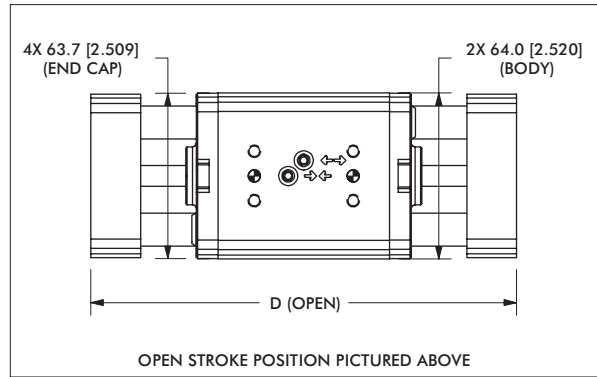
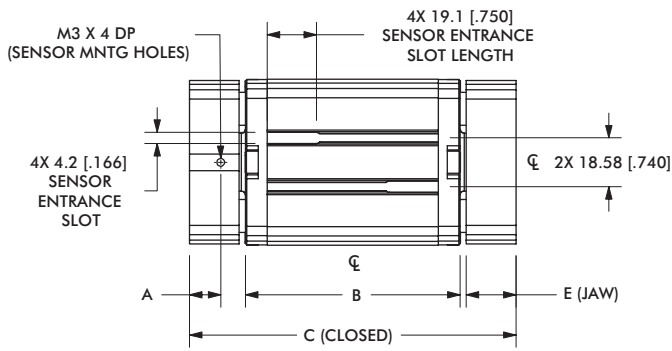

Model	A	B	C	D	E
DPW-500M-1	12.1 [0.475]	82.8 [3.260]	125 [4.96]	164 [6.46]	19.2 [0.755]
DPW-500M-2	14.9 [0.585]	108.2 [4.260]	177 [6.96]	240 [9.46]	31.9 [1.255]

Sensor Accessories	500M
Inductive Sensor Mtg Kit (3mm or 4mm)	OSMK-118

Seal Repair Kits	500M
Buna-N Seal Repair Kit	SLKT-341
Viton® Seal Repair Kit	SLKT-341V
Viton® Manifold Seal Kit	SLKT-199V
Shaft Wiper Seal Kit	SLKT-342

Loading Information

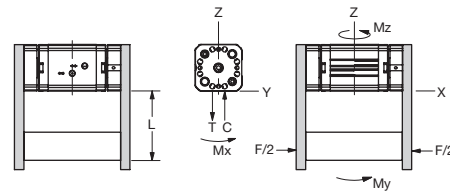
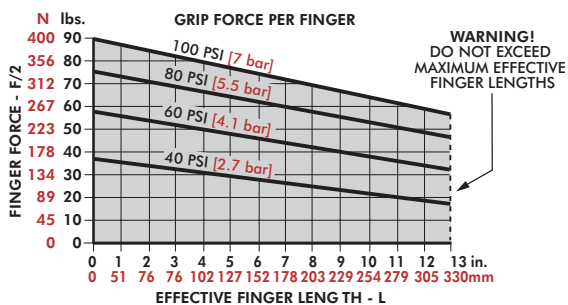

DPW-500M	Static	Dynamic
Maximum Tensile T	2668 N [600 lbs]	267 N [60 lbs]
Maximum Compressive C	2668 N [600 lbs]	267 N [60 lbs]
Maximum Moment M_x	68 Nm [600 in-lbs]	7 Nm [60 in-lbs]
Maximum Moment M_y	102 Nm [900 in-lbs]	10 Nm [90 in-lbs]
Maximum Moment M_z	68 Nm [600 in-lbs]	7 Nm [60 in-lbs]

*Capacities are per set of jaws and are not simultaneous

RPB SERIES

2-Jaw Heavy-Duty Parallel Grippers | Features and Benefits | How to Order

Features:

- High accuracy, sealed, low friction roller bearing, long stroke gripper
- Grip force of 2669N with strokes from 101 mm [3.98 in] to 203 mm [7.99 in] (maintains full grip force even at long finger lengths)
- Rack and pinion design for high repeatability
- Purge ports maintain long term smooth operation in harsh environments.
- Viton® seals for extended temperature operating range.
- Optional non-synchronous jaw operation
- Part sensing using up to 4 inductive sensors



Applications:

- Foundry applications
- Gantry systems
- Large heavy part handling
- Long finger lengths

RPB Series How To Order

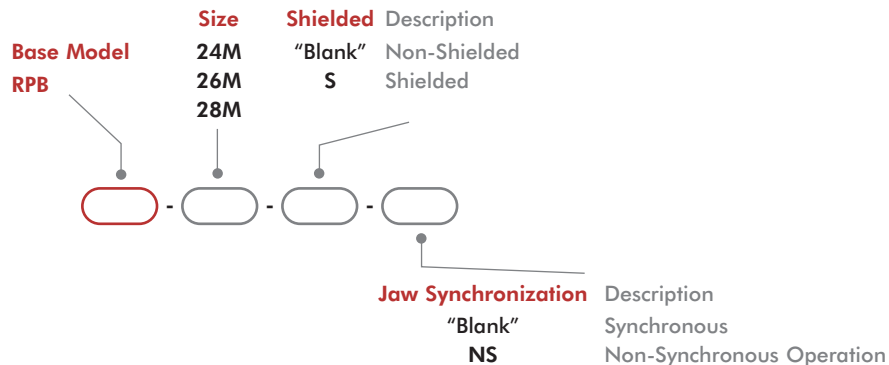

RPB Series Accessories

Sensor Accessories	Model Numbers	Part Number	Qty/Unit
12mm Sensor Mounting Kit (mounts 2 sensors)	24, 26, 28	OSMK-078	1-2
12mm Sensor Mounting Kit (mounts 2 sensors)	24-S, 26-S, 28-S	OSMK-079	1-2
12mm PNP Inductive Sensor with Quick Disconnect*	All Models	OISP-017	1-4
12mm NPN Inductive Sensor with Quick Disconnect*	All Models	OISN-017	1-4
Quick Disconnect 2 Meter Cable Length*	All Models	CABL-014	1-4

Pneumatic Accessories	Model Numbers	Part Number	Qty/Unit
Fail Safe Valve (Metric)	All Models	OFSV-006	1

*Sensor and cable sold separately.

2-Jaw Heavy-Duty Parallel Grippers | Technical Specifications

Specifications	Units	24M, 24M-S	26M, 26M-S	28M, 28M-S
Total Rated Grip Force F @ 7 bar [100 psi]	N [lbf]	2669 [600]		
Total Stroke	mm [in]	101.6 [4]	152.4 [6]	203.2 [8]
Weight	kg [lb]	10.9 [24]	14.5 [32]	19.1 [42]
Pressure Range	bar [psi]	1.4-7 [20-100]		
Cylinder Bore Ø	mm [in]	50.8 [2.000]		
Displacement	cm ³ [in ³]	204.8 [12.5]	308.1 [18.8]	410 [25]
Temperature Range (Viton® seals)	°C [°F]	-30°~150° [-20°~300°]		
Actuation	sec	0.5	0.75	1.00
Accuracy	mm [in]	±0.13 [±0.005]		
Repeatability	mm[in]	±0.05 [±0.0020]		
Valve to Actuate Double Acting		4-way, 2-position		

RPB-24M, -26M, -28M

2-Jaw Heavy-Duty Parallel Grippers | Dimensions and Technical Specifications

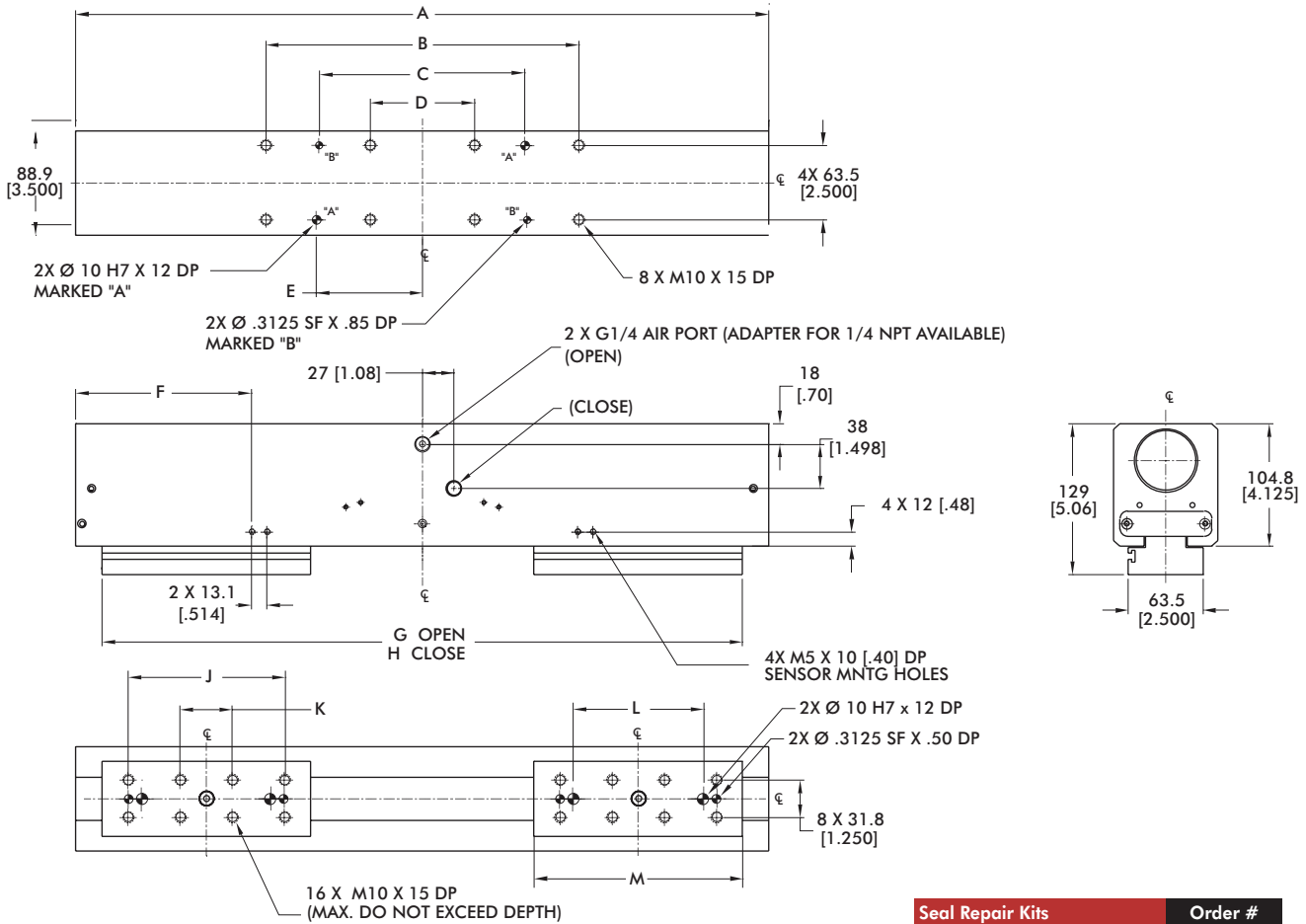

Seal Repair Kits	Order #
Viton® Seal Repair Kit	SLKT-123V

Model	A	B	C	D	E	F	G	H	J	K	L	M
RPB-24M	438.2 [17.250]	152.4 [6.000]	101.6 [4.000]	50.8 [2.000]	50.8 [2.000]	98.9 [3.90]	394 [15.50]	292 [11.50]	101.6 [4.000]	38.1 [1.500]	82.0 [3.2284]	127.0 [5.000]
RPB-26M	590.5 [23.250]	266.7 [10.500]	177.8 [7.000]	88.9 [3.500]	88.9 [3.500]	150 [5.90]	546 [21.50]	394 [15.50]	133.4 [5.250]	44.5 [1.750]	112.0 [4.4094]	178 [7.00]
RPB-28M	743.0 [29.250]	381.0 [15.000]	254.0 [10.000]	127.0 [5.000]	127.0 [5.000]	188 [7.39]	699 [27.50]	495 [19.50]	165.1 [6.500]	50.8 [2.000]	140.0 [5.5118]	229 [9.00]

Loading Information

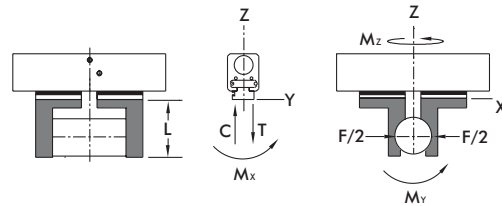
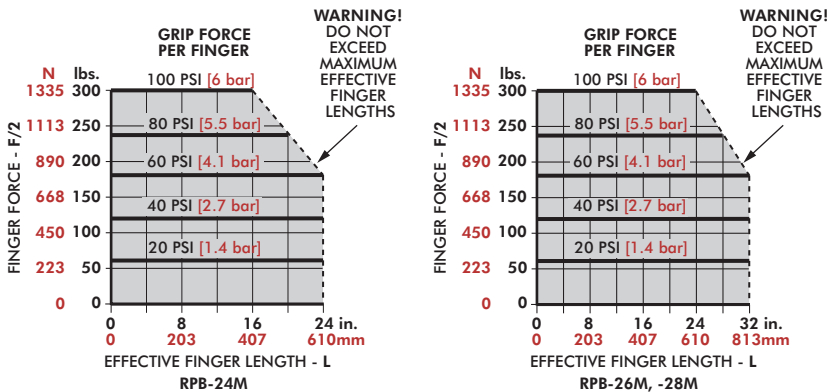

Static Load	-24M	-26M, -28M
Maximum Tensile T	6672 N [1500 lbs]	8896 N [2000 lbs]
Maximum Compressive C	6672 N [1500 lbs]	8896 N [2000 lbs]
Maximum Moment M _x	339 Nm [3000 in-lbs]	396 Nm [3500 in-lbs]
Maximum Moment M _y	339 Nm [3000 in-lbs]	396 Nm [3500 in-lbs]
Maximum Moment M _z	339 Nm [3000 in-lbs]	396 Nm [3500 in-lbs]

*Capacities are per set of jaws and are not simultaneous

RPB-24M-S, -26M-S, -28M-S

2-Jaw Heavy-Duty Parallel Grippers | Dimensions and Technical Specifications

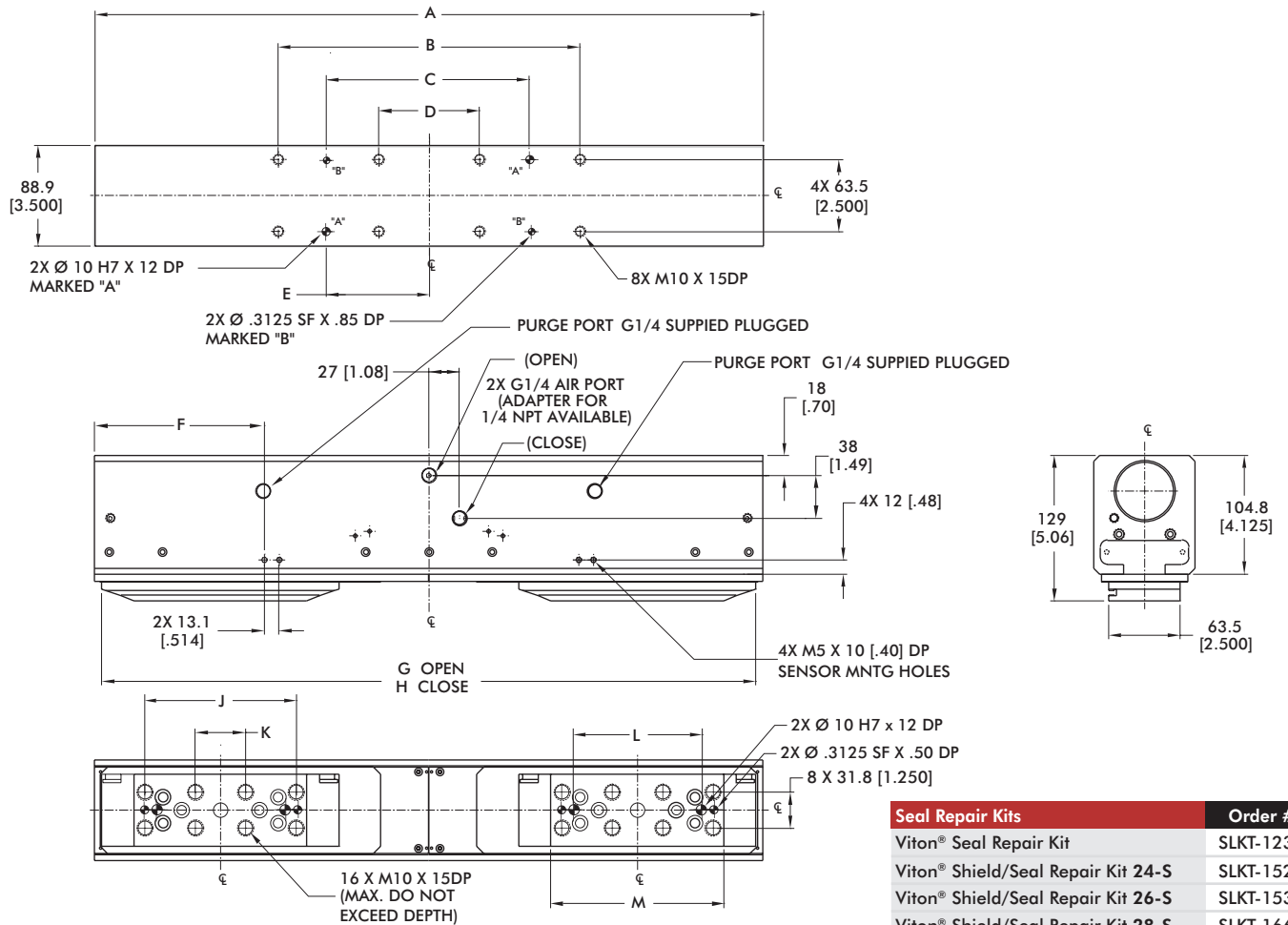

Seal Repair Kits	Order #
Viton® Seal Repair Kit	SLKT-123V
Viton® Shield/Seal Repair Kit 24-S	SLKT-152V
Viton® Shield/Seal Repair Kit 26-S	SLKT-153V
Viton® Shield/Seal Repair Kit 28-S	SLKT-166V

Model	A	B	C	D	E	F	G	H	J	K	L	M
RPB-24M-S	438.2 [17.250]	152.4 [6.000]	101.6 [4.000]	50.8 [2.000]	50.8 [2.000]	98.9 [3.90]	427 [16.82]	325 [12.79]	101.6 [4.000]	38.1 [1.500]	82.0 [3.2284]	124 [4.88]
RPB-26M-S	590.5 [23.250]	266.7 [10.500]	177.8 [7.000]	88.9 [3.500]	88.9 [3.500]	150 [5.90]	578 [22.75]	425 [16.75]	133.4 [5.250]	44.5 [1.750]	112.0 [1.4094]	153 [6.03]
RPB-28M-S	743.0 [29.250]	381.0 [15.000]	254.0 [10.000]	127.0 [5.000]	127.0 [5.000]	188 [7.39]	724 [28.50]	521 [20.50]	165.1 [6.500]	50.8 [2.000]	140.0 [5.5118]	197 [7.77]

Loading Information

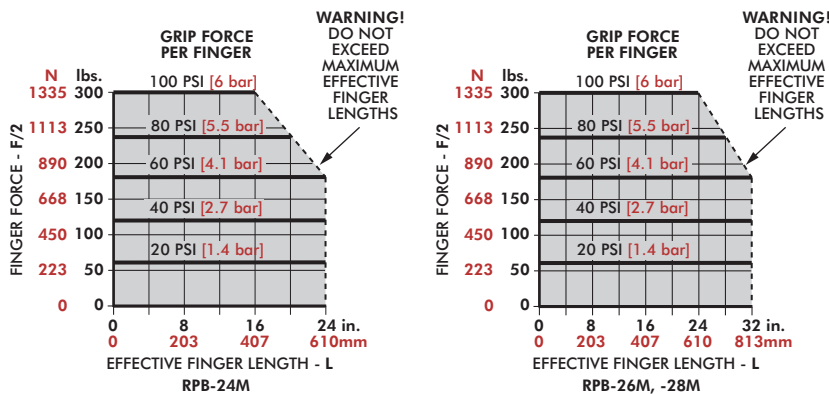
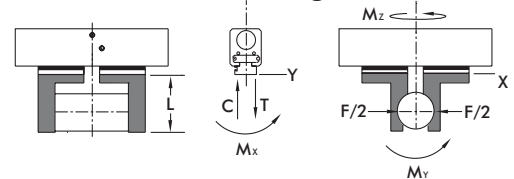

Static Load	-24M	-26M, -28M
Maximum Tensile T	6672 N [1500 lbs]	8896 N [2000 lbs]
Maximum Compressive C	6672 N [1500 lbs]	8896 N [2000 lbs]
Maximum Moment Mx	339 Nm [3000 in-lbs]	396 Nm [3500 in-lbs]
Maximum Moment My	339 Nm [3000 in-lbs]	396 Nm [3500 in-lbs]
Maximum Moment Mz	339 Nm [3000 in-lbs]	396 Nm [3500 in-lbs]

*Capacities are per set of jaws and are not simultaneous

RPR SERIES

2-Jaw Heavy-Duty Parallel Grippers | Features and Benefits | How To Order

Features:

- High rigidity and robust long stroke gripper
- Grip force of 3250 N [791 lbf] with strokes from 150 mm [5.91 in] to 350 mm [13.78 in]
- Rack and Pinion for synchronized jaw operation
- Optional Integral Rod Lock that lock jaws in position upon air loss
- Shaft wiper seals protects internal bearings from contaminants
- Optional Viton® seals for high temp applications
- Customized sensing and linear encoder solutions available

Applications:

- Foundry applications
- Gantry Systems
- Large heavy part handling



How To Order

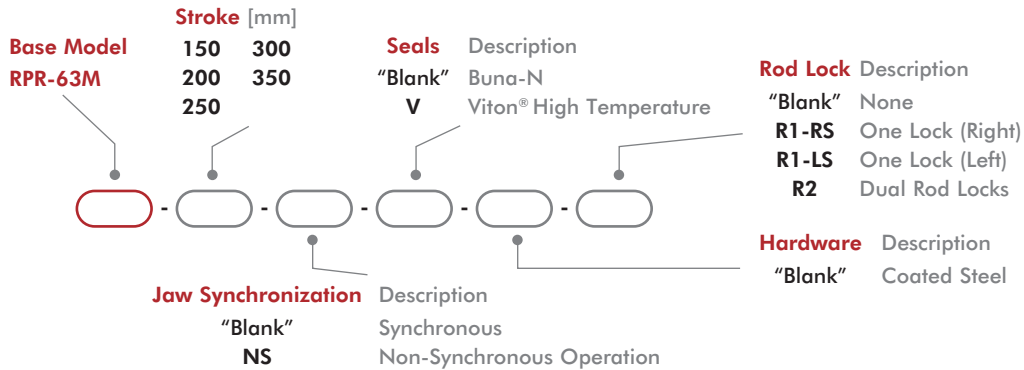

Accessories

Sensor Accessories	Part Number	Qty/Unit
Sensor Mounting Kit for Imperial & Metric Units (mounts 2 sensors)	OSMK-131	1
12mm PNP Inductive Sensor with Quick Disconnect*	OISP-017	1-2
12mm NPN Inductive Sensor with Quick Disconnect*	OISN-017	1-2
Quick Disconnect 2 Meter Cable Length*	CABL-014	1-2
Quick Disconnect 5 Meter Cable Length*	CABL-018	1-2

Pneumatic Accessories	Part Number	Qty/Unit
Fail Safe Valve 1/4 BSPP	OFSV-006	1
Buna-N Seal Repair Kit	SLKT-452	1
Viton® Seal Repair Kit	SLKT-453	1

*Sensor and cable sold separately.

2-Jaw Heavy-Duty Parallel Grippers | Technical Specifications

Specifications	Units	RPR-63M-150	RPR-63M-200	RPR-63M-250	RPR-63M-300	RPR-63M-350
Total Rated Grip Force F @ 7 bar [100 psi]	N [lbf]	3250 [791]				
Total Stroke	mm [in]	150 [5.91]	200 [7.87]	250 [9.84]	300 [11.81]	350 [13.78]
Weight	kg [lb]	13.6 [30]	15.8 [35]	18.1 [40]	20.4 [45]	22.7 [50]
Ingress Protection Class (IP)		IP65				
Pressure Range	bar [psi]	3-7 [40-100]				
Displacement	cm ³ [in ³]	623 [38.2]				
Temperature Range (Buna-N seals)	°C [°F]	-35°~80° [-30°~180°]				
Temperature Range (Viton® seals)	°C [°F]	-30°~150° [-20°~300]				
Actuation	sec	1.0	1.3	1.6	1.8	2.0
Accuracy	mm [in]	±0.13 [±0.005]				
Repeatability	mm [in]	±0.05 [±0.002]				
Valve to Actuate Double Acting		4-way, 2-position				

RPR-63M

2-Jaw Heavy-Duty Parallel Grippers | Dimensions and Technical Specifications

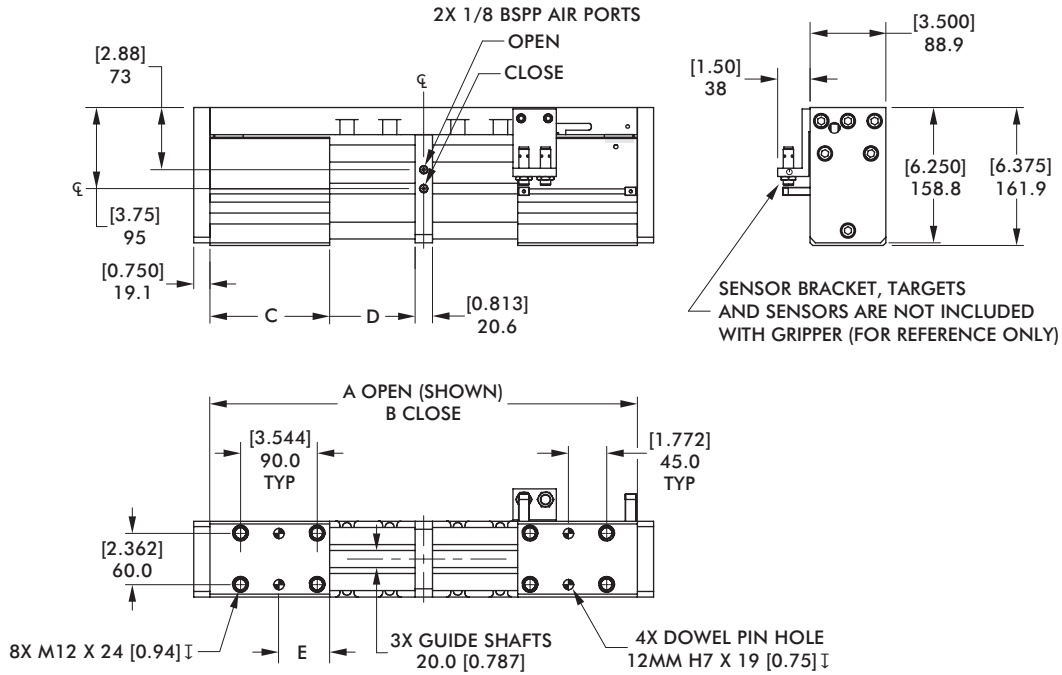

RPR-63-250 SHOWN

Model	A	B	C	D	E
RPR-63M-150	[12.27] 311.6	[6.34] 161.1	[5.51] 140	[2.96] 75.3	
RPR-63M-200	[19.75] 501.7	[11.87] 301.6		[3.94] 100	[2.34] 59.6
RPR-63M-250	[23.81] 604.7	[13.96] 354.7	[6.58] 167	[4.92] 125	
RPR-63M-300	[28.15] 715	[16.21] 411.8	[7.70] 195.6	[5.97] 151.6	[3.50] 88.8
RPR-63M-350	[31.75] 806.5	[17.71] 449.9	[8.45] 214.6	[7.02] 178.3	[4.25] 107.6

Loading Information

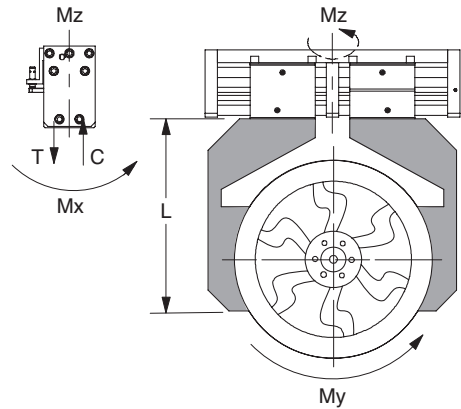
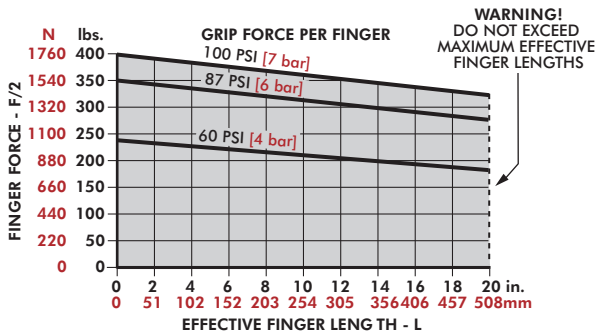

RPR-63M	
Maximum Tensile T	15570 N [3500 lbs]
Maximum Compressive C	15570 N [3500 lbs]
Maximum Moment M_x	825 Nm [7302 in-lbs]
Maximum Moment M_y	990 Nm [8762 in-lbs]
Maximum Moment M_z	825 Nm [7302 in-lbs]
Maximum Finger Length L	500mm [20 in]

*Capacities are per set of jaws and are not simultaneous

2-Jaw Heavy-Duty Parallel Grippers | Dimensions

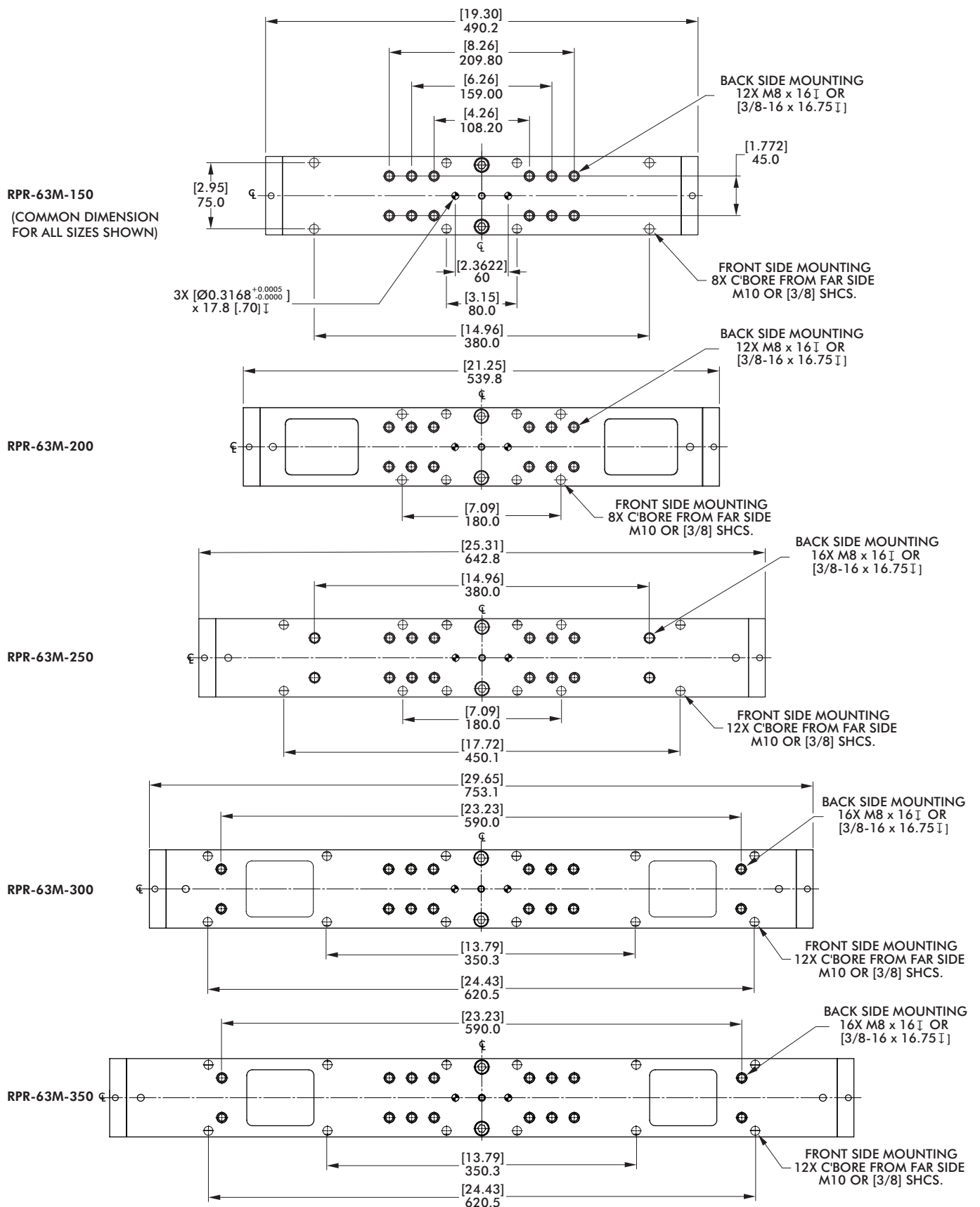

RPW SERIES

2-Jaw Heavy-Duty Parallel Grippers | Features and Benefits | How To Order

Features:

- Robust wide body gripper
- Grip force ranges from 222N thru 2091N
- Strokes range from 19mm thru 114mm
- Rack and pinion design for smooth operation
- Jaws well supported to grip large and wide parts
- Double rod seals for extended life in harsh environments
- Optional non-synchronous jaw operation

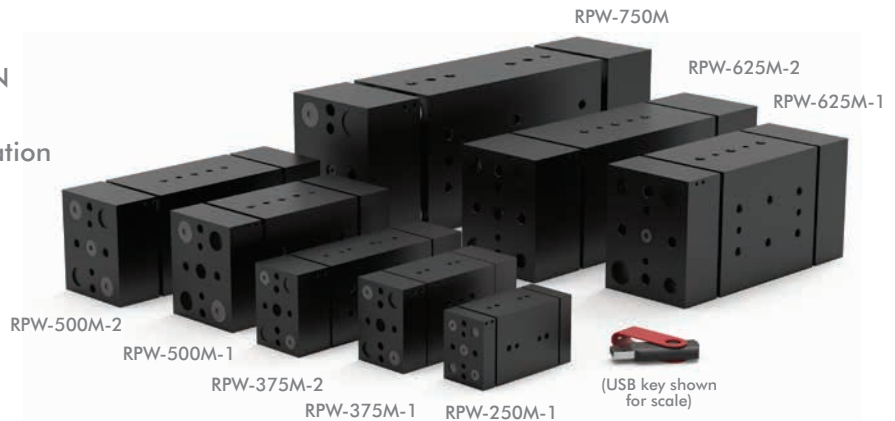

Applications:

- Wide part gripping
- Gantry systems
- Harsh gripping environment

How To Order

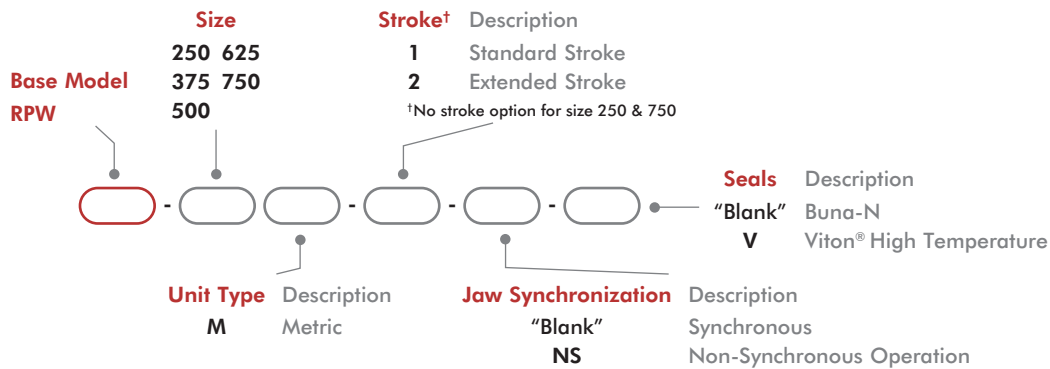

Accessories

Sensor Accessories	Model Numbers	Part Number	Qty/Unit
Sensor Mounting Kit for Imperial & Metric Units (mounts 2 sensors)	See Datasheet		1
PNP Inductive Sensor with Quick Disconnect*	250, 375, 500	OISP-014	1-2
NPN Inductive Sensor with Quick Disconnect*	250, 375, 500	OISN-014	1-2
PNP Inductive Sensor with Quick Disconnect*	625, 750	OISP-011	1-2
NPN Inductive Sensor with Quick Disconnect*	625, 750	OISN-011	1-2
Quick Disconnect 2 Meter Cable Length*	All Models	CABL-010	1-2
Quick Disconnect 5 Meter Cable Length*	All Models	CABL-013	1-2

Pneumatic Accessories	Model Numbers	Part Number	Qty/Unit
Fail Safe Valve (Imperial)	250, 375	OFSV-001	1
Fail Safe Valve (Metric)	250, 375	OFSV-004	1
Fail Safe Valve (Imperial)	500, 625, 750	OFSV-002	1
Fail Safe Valve (Metric)	500, 625, 750	OFSV-005	1

* Sensor and cable sold separately.

2-Jaw Heavy-Duty Parallel Grippers | Technical Specifications

Specifications	Units	250	375-1	375M-2
Total Rated Grip Force F @ 7 bar [100 psi]	N [lbf]	222 [50]	400 [90]	
Total Stroke	mm [in]	19.1 [0.75]	25.4 [1.00]	50.8 [2.00]
Weight	kg [lb]	0.30 [0.66]	0.59 [1.3]	0.91 [2.0]
Pressure Range	bar [psi]	3-7 [40-100]		
Ingress Protection Class (IP)		IP54		
Displacement	cm ³ [in ³]	3.8 [0.023]	9.8 [0.600]	19.7 [1.200]
Temperature Range (Buna-N seals)	°C [°F]	-35°~80° [-30°~180°]		
Temperature Range (Viton® seals)	°C [°F]	-30°~150° [-20°~300°]		
Actuation	sec	0.16	0.20	0.25
Accuracy	mm [in]	±0.05 [±0.002]		
Repeatability	mm [in]	±0.03 [±0.001]		
Valve to Actuate Double Acting		4-way, 2-position		

Specifications	Units	500-1	500-2
Total Rated Grip Force F @ 7 bar [100 psi]	N [lbf]	667 [150]	
Total Stroke	mm [in]	38.1 [1.50]	63.5 [2.50]
Weight	kg [lb]	1.4 [3.0]	1.85 [4.0]
Pressure Range	bar [psi]	3-7 [40-100]	
Ingress Protection Class (IP)		IP54	
Displacement	cm ³ [in ³]	29.5 [1.800]	49.2 [3.000]
Temperature Range (Buna-N seals)	°C [°F]	-35°~80° [-30°~180°]	
Temperature Range (Viton® seals)	°C [°F]	-30°~150° [-20°~300°]	
Actuation	sec	0.25	0.33
Accuracy	mm [in]	±0.08 [±0.003]	
Repeatability	mm [in]	±0.03 [±0.001]	
Valve to Actuate Double Acting		4-way, 2-position	

Specifications	Units	625-1	625-2	750
Total Rated Grip Force F @ 7 bar [100 psi]	N [lbf]	1068 [240]		2091 [470]
Total Stroke	mm [in]	50.8 [2.00]	88.9 [3.50]	114.3 [4.50]
Weight	kg [lb]	3.0 [6.5]	3.6 [7.8]	6.4 [14]
Pressure Range	bar [psi]	3-7 [40-100]		
Ingress Protection Class (IP)		IP54		
Displacement	cm ³ [in ³]	21.6 [1.320]	37.9 [2.310]	232.7 [14.200]
Temperature Range (Buna-N seals)	°C [°F]	-35°~80° [-30°~180°]		
Temperature Range (Viton® seals)	°C [°F]	-30°~150° [-20°~300°]		
Actuation	sec	0.52	0.69	1.00
Accuracy	mm [in]	±0.08 [±0.003]		
Repeatability	mm [in]	±0.03 [±0.001]		
Valve to Actuate Double Acting		4-way, 2-position		

RPW-250M

2-Jaw Heavy-Duty Parallel Grippers | Dimensions and Technical Specifications

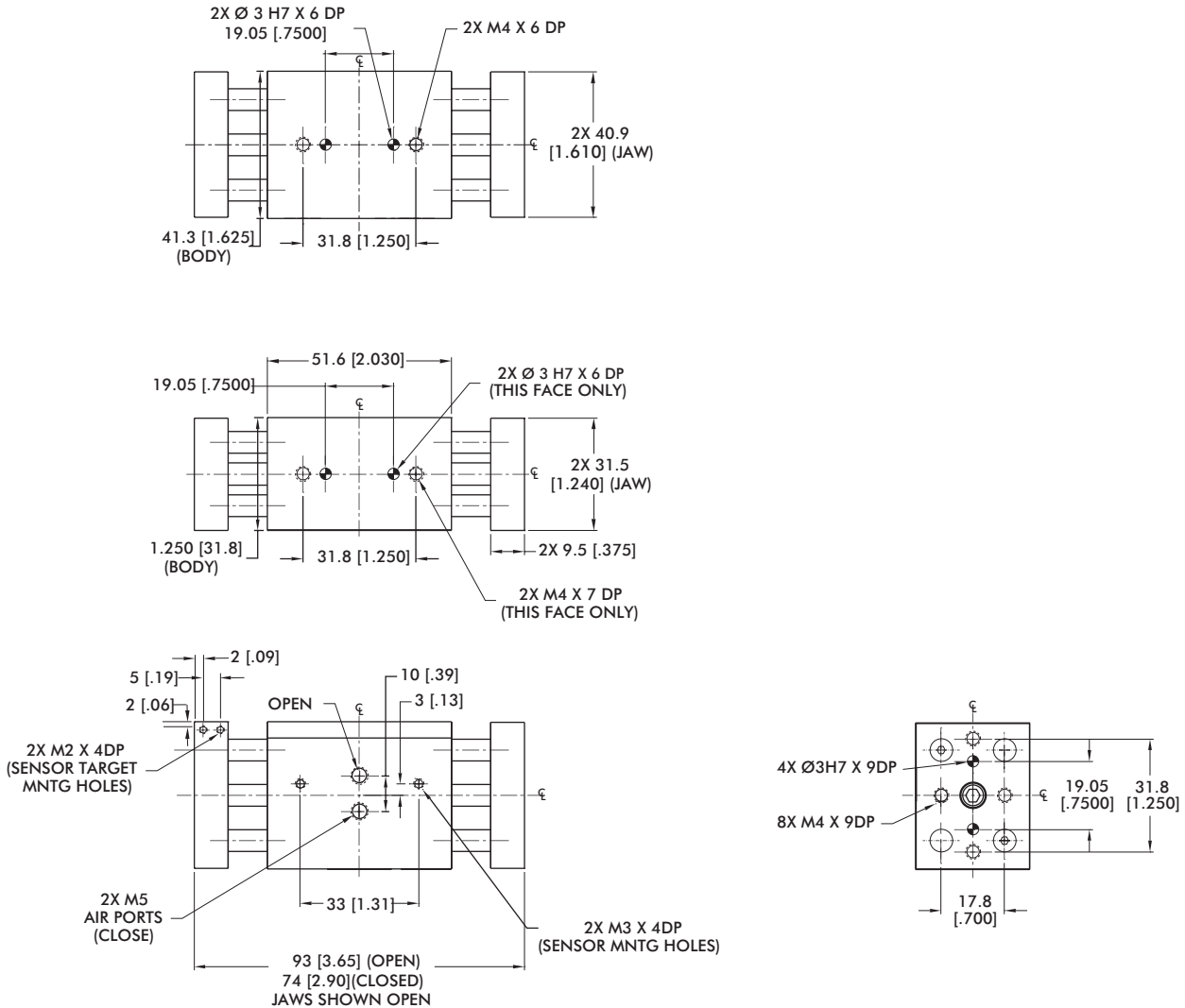

Sensor Accessories	250
Inductive Sensor Mtg Kit (2 Sensors)	OSMK-009
Seal Repair Kits	250
Buna-N Seal Repair Kit	SLKT-055
Viton® Seal Repair Kit	SLKT-055V

Loading Information

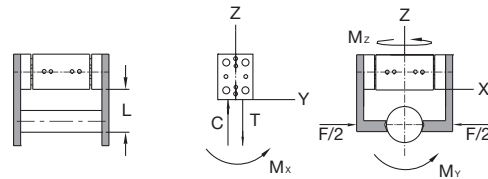
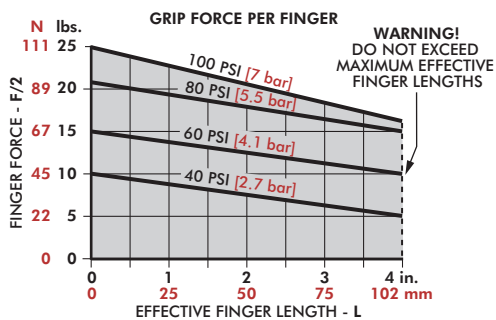

RPW-250M	Static	Dynamic
Maximum Tensile T	[50 lb] 222 N	[10 lb] 44 N
Maximum Compressive C	[50 lb] 222 N	[10 lb] 44 N
Maximum Moment M _x	[100 in-lb] 11 Nm	[20 in-lb] 2 Nm
Maximum Moment M _y	[150 in-lb] 17 Nm	[30 in-lb] 3 Nm
Maximum Moment M _z	[100 in-lb] 11 Nm	[20 in-lb] 2 Nm

*Capacities are per set of jaws and are not simultaneous

2-Jaw Heavy-Duty Parallel Grippers | Dimensions and Technical Specifications

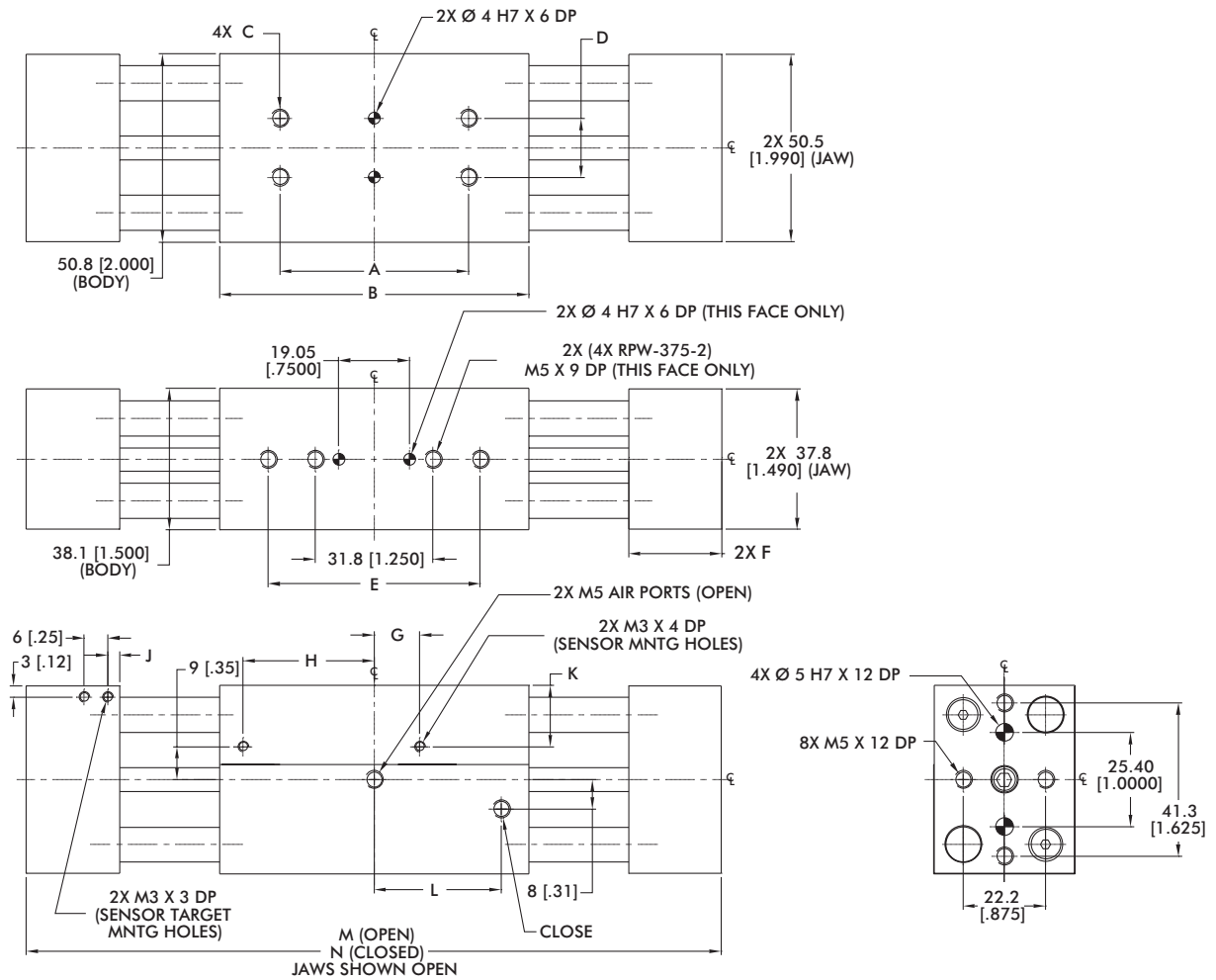

Sensor Accessories	375
Inductive Sensor Mtg Kit for 375-1 (2 Sensors)	OSMK-010
Inductive Sensor Mtg Kit for 375-2 (2 Sensors)	OSMK-011

Seal Repair Kits	375
Buna-N Seal Repair Kit	SLKT-056
Viton® Seal Repair Kit	SLKT-056V

Model	A	B	C	D	E	F	G	H	J	K	L	M	N
RPW-375M-1	19.05 [0.7500]	19.0 [0.750]	M4 x 6 DP [#8-32 x.25 DP]	19.05 [0.7500]	--	18.8 [0.740]	13 [0.52]	22 [0.85]	3 [0.12]	9 [0.35]	21 [0.81]	120 [4.74]	95 [3.74]
RPW-375M-2	50.8 [2.000]	83.3 [3.280]	M5 x 6 DP [#10-32 x.25 DP]	15.88 [0.6250]	57.2 [2.250]	25.1 [0.990]	12 [0.49]	35 [1.39]	3 [0.13]	17 [0.65]	34 [1.35]	187 [7.38]	136 [5.38]

Loading Information

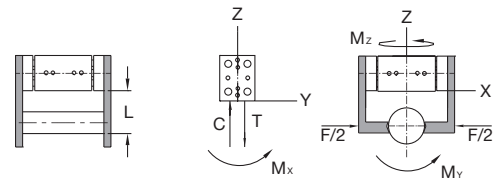
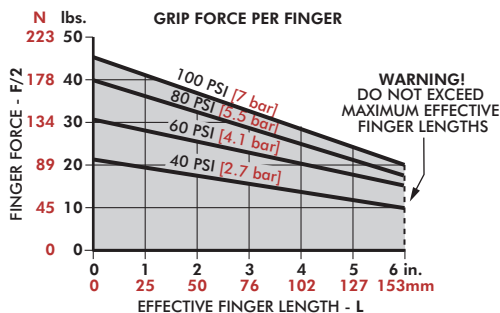

RPW-375M	Static	Dynamic
Maximum Tensile T	[100 lb] 445 N	[20 lb] 89 N
Maximum Compressive C	[100 lb] 445 N	[20 lb] 89 N
Maximum Moment M _x	[175 in-lb] 20 Nm	[35 in-lb] 4 Nm
Maximum Moment M _y	[250 in-lb] 28 Nm	[50 in-lb] 6 Nm
Maximum Moment M _z	[175 in-lb] 20 Nm	[35 in-lb] 4 Nm

*Capacities are per set of jaws and are not simultaneous

RPW-500M

2-Jaw Heavy-Duty Parallel Grippers | Dimensions and Technical Specifications

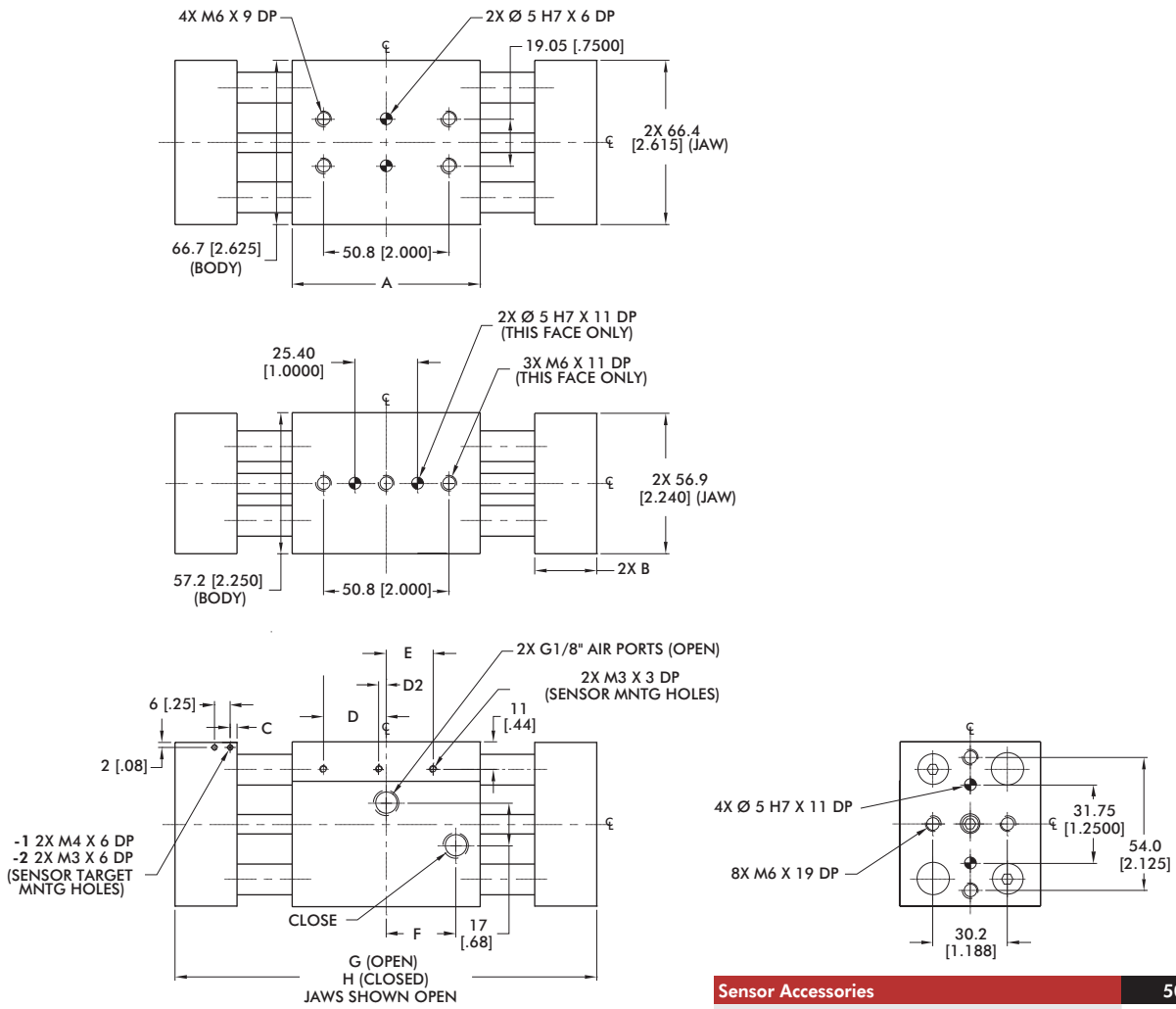

Sensor Accessories		500
Inductive Sensor Mtg Kit for 500-1 (2 Sensors)		OSMK-012
Inductive Sensor Mtg Kit for 500-2 (2 Sensors)		OSMK-013
Seal Repair Kits		500
Buna-N Seal Repair Kit		SLKT-058
Viton® Seal Repair Kit		SLKT-058V

Model	A	B	C	D	D2	E	F	G	H
RPW-500M-1	76.2 [3.000]	25.1 [0.990]	2.8 [0.11]	25 [1.00]	--	19 [0.75]	28 [1.11]	171 [6.73]	132 [5.23]
RPW-500M-2	101.6 [4.000]	31.3 [1.235]	3.3 [0.13]	38 [1.51]	3 [0.13]	--	41 [1.61]	234 [9.23]	170 [6.73]

Loading Information

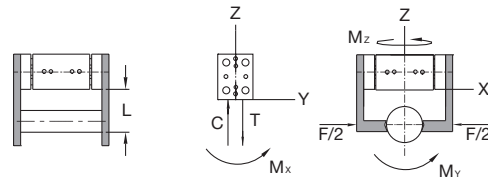
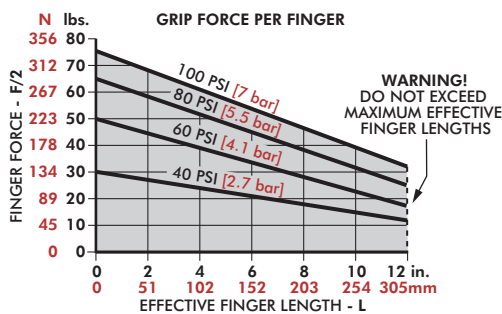

RPW-500M	Static	Dynamic
Maximum Tensile T	[500 lb] 2224 N	[50 lb] 222 N
Maximum Compressive C	[500 lb] 2224 N	[50 lb] 222 N
Maximum Moment M_x	[500 in-lb] 57 Nm	[50 in-lb] 6 Nm
Maximum Moment M_y	[750 in-lb] 85 Nm	[75 in-lb] 8 Nm
Maximum Moment M_z	[500 in-lb] 57 Nm	[50 in-lb] 6 Nm

*Capacities are per set of jaws and are not simultaneous

2-Jaw Heavy-Duty Parallel Grippers | Dimensions and Technical Specifications

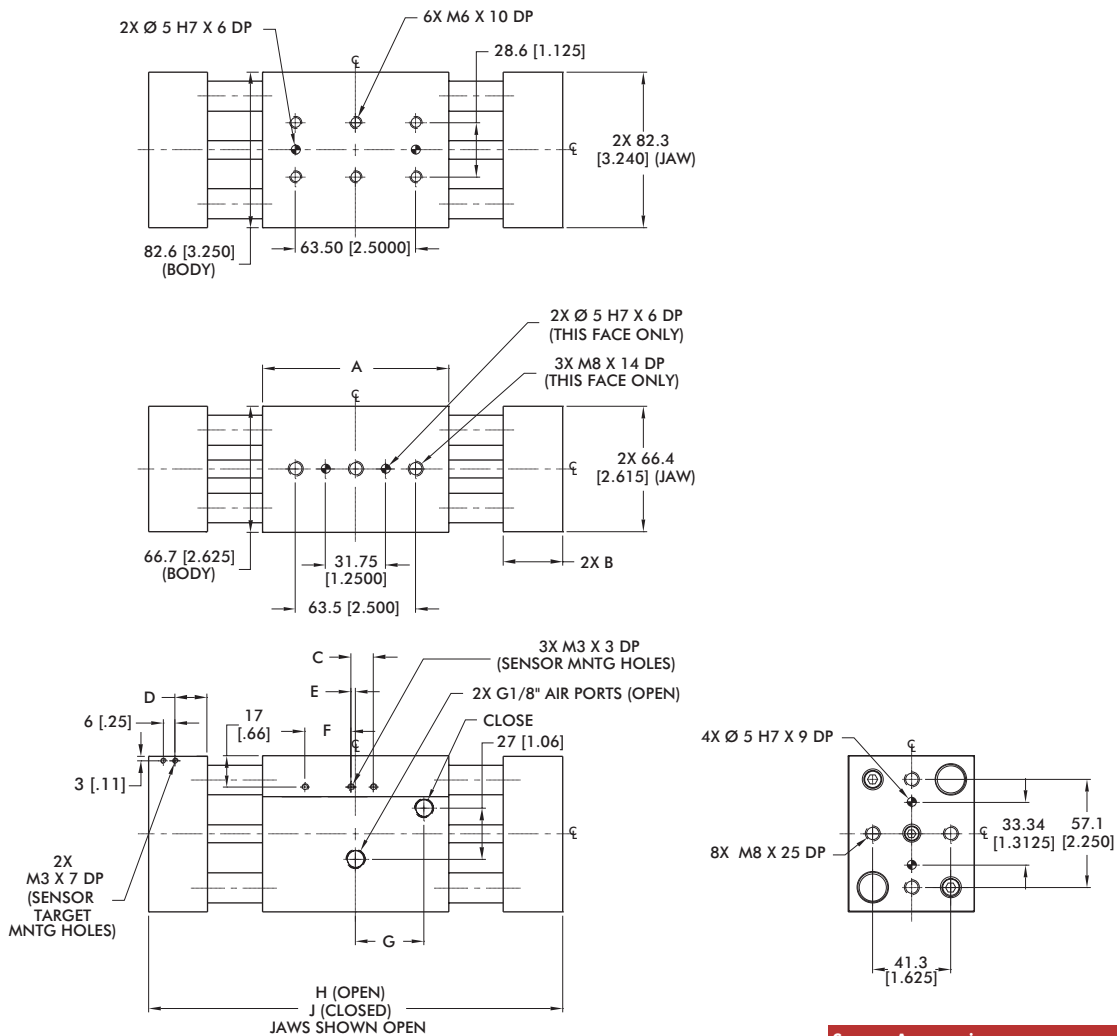

Sensor Accessories	625
Inductive Sensor Mtg Kit (2 Sensors)	OSMK-074
Seal Repair Kits	625
Buna-N Seal Repair Kit	SLKT-071
Viton® Seal Repair Kit	SLKT-071V

Model	A	B	C	D	E	F	G	H	J
RPW-625M-1	98.4 [3.875]	31.4 [1.235]	14 [0.55]	17 [0.66]	2 [0.08]	24 [0.96]	36 [1.42]	219 [8.63]	168 [6.63]
RPW-625M-2	136.5 [5.375]	44.1 [1.735]	15 [0.61]	5 [0.21]	9 [0.37]	43 [1.71]	55 [2.17]	321 [12.63]	232 [9.13]

Loading Information

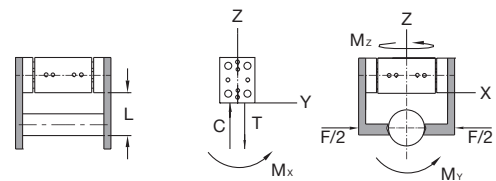
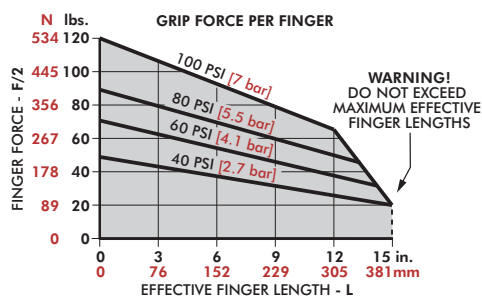

RPW-625M	Static	Dynamic
Maximum Tensile T	[1200 lbs] 5338 N	[125 lbs] 556 N
Maximum Compressive C	[1200 lbs] 5338 N	[125 lbs] 556 N
Maximum Moment M _x	[1000 in-lbs] 113 Nm	[100 in-lbs] 11 Nm
Maximum Moment M _y	[1500 in-lbs] 170 Nm	[125 in-lbs] 14 Nm
Maximum Moment M _z	[1000 in-lbs] 113 Nm	[100 in-lbs] 11 Nm

*Capacities are per set of jaws and are not simultaneous

RPW-750M

2-Jaw Heavy-Duty Parallel Grippers | Dimensions and Technical Specifications

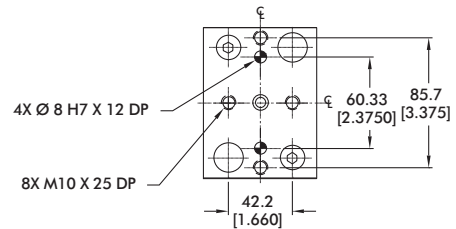
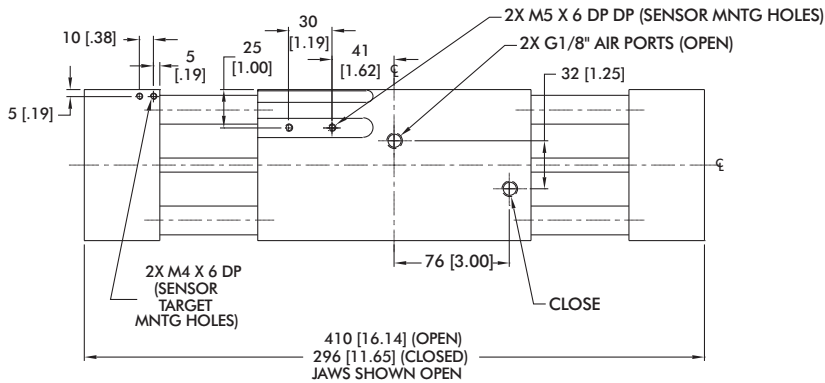
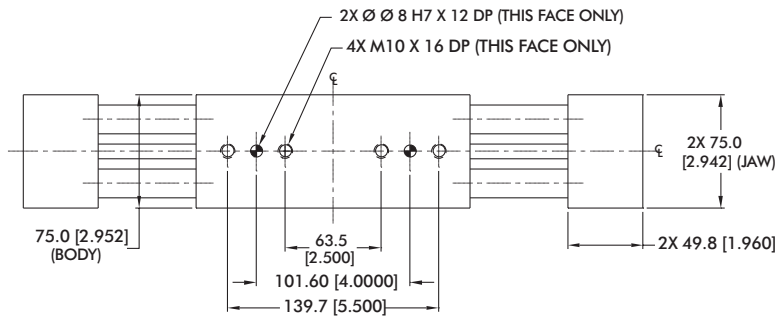
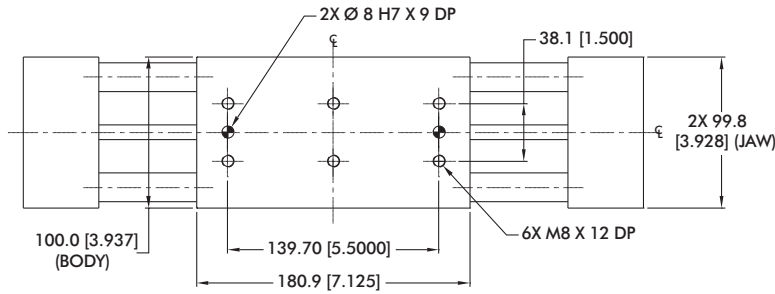

Sensor Accessories	750
Inductive Sensor Mtg Kit (2 Sensors)	OSMK-014

Seal Repair Kits	750
Buna-N Seal Repair Kit	SLKT-060
Viton® Seal Repair Kit	SLKT-060V

Loading Information

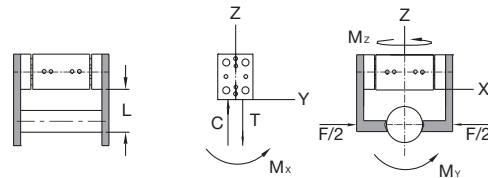
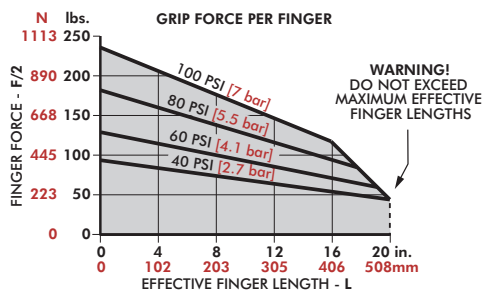





RPW-750M	Static	Dynamic
Maximum Tensile T	11121 N [2500 lb]	1112 N [250 lb]
Maximum Compressive C	11121 N [2500 lb]	1112 N [250 lb]
Maximum Moment M_x	226 Nm [2000 in-lb]	22 Nm [200 in-lb]
Maximum Moment M_y	339 Nm [3000 in-lb]	28 Nm [250 in-lb]
Maximum Moment M_z	226 Nm [2000 in-lb]	22 Nm [200 in-lb]

*Capacities are per set of jaws and are not simultaneous

3-JAW PARALLEL GRIPPER SERIES

3-Jaw Parallel Grippers | Dimensions and Technical Specifications

Model	Stroke mm [in]	Grip Force N [lbs]	Operating Environment	Special Features	Page GR-3JP-#
3P 	10-50 [0.39-1.97]	422-11190 [95-2515]	IP54	Shielded Gripper with Spring Assist. Ideal for Round Parts. Tandem Cylinder Option. High Precision.	3
RTH 	4-70 [0.1575-2.756]	445-44353 [100-9971]	IP55 Using Purge Port. Cleanroom Class 100, ISO 5 Using Scavenge Port	Shielded for Harsh & Rugged Applications. Suitable for Machining and Coolant Applications. High Precision. Spring Assist.	15
PPC 	10-30 [0.394-1.181]	747-4332 [168-974]	IP54	Hole Through Center. High Precision. Harsh Environments. Round Parts Handling.	25
REP3 	10-30 [0.39-1.181]	480-3268 [108-753]	IP55. Cleanroom Class 100, ISO 5 Using Scavenge Port	Spring Assist. Rugged and Harsh Environments. Round Parts. High Precision.	31
RPC 	7.6-34.9 [0.3-1.38]	445-13345 [100-3000]	IP54	Harsh & Rugged Applications. High Precision. Round Parts Handling.	37

ENGINEERED RELIABILITY

Grippers, Rotates, and Linear Slide Solutions



Global Automation Solutions

DESTACO's Robohand products are engineered for reliability and long life to ensure maximum production uptime. These products are designed and machined for precise repeatability with minimal maintenance.



destaco.com

End Effectors | Grippers | Indexers | Manual Clamps | Power Clamps | Remote Handling

3P SERIES

3-Jaw Parallel Grippers | Features and Benefits | How To Order

Features:

- Robust and powerful precision multi-purpose gripper
- Pneumatic or hydraulic powered operation
- Optional tandem cylinder doubles grip force
- Protective boot and shielded design for harsh environments
- Spring assist option maintains grip in case of air pressure loss
- Uses inductive sensors for jaw position detection

Applications:

- Hydraulic powered gripping applications
- Confined spaces in harsh environment applications
- Welding applications with protective boot option



How To Order

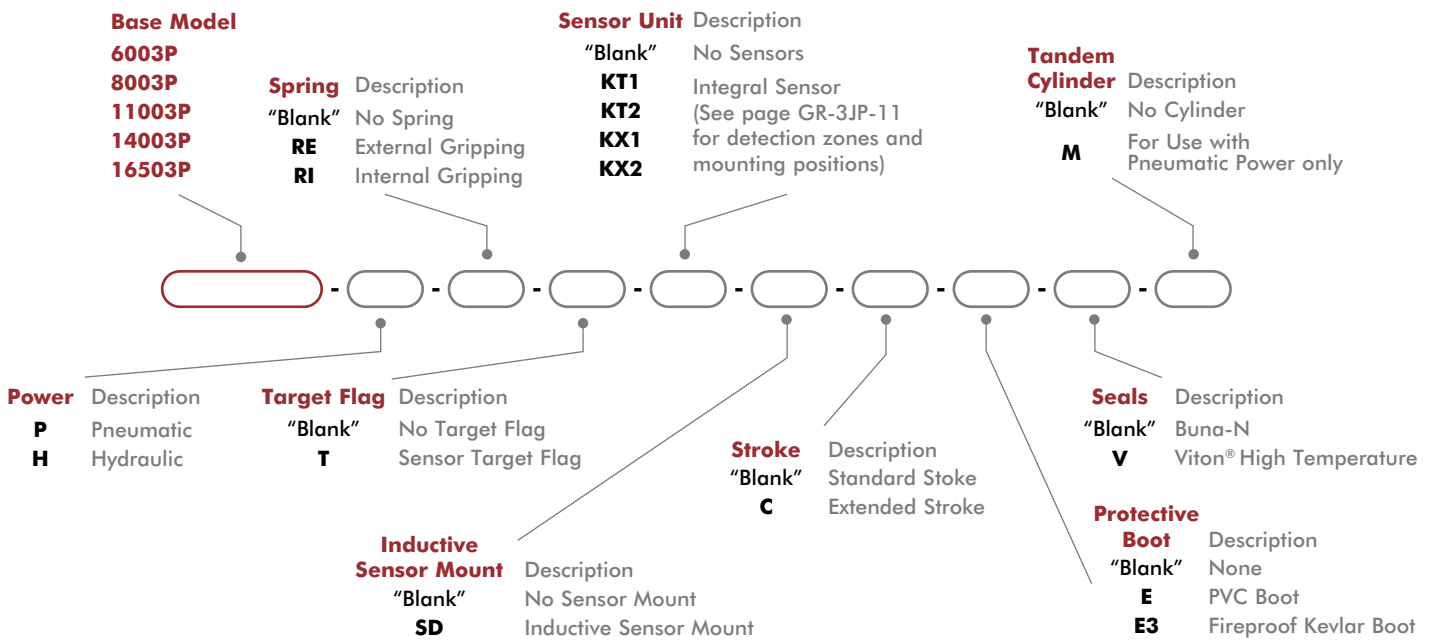

Accessories

Sensor Accessories	Model Numbers	Part Number	Qty/Unit
M8 Inductive Sensor PNP with M8 Connector	6003P, 8003P, 11003P	OISP-011	1-4
M8 Inductive Sensor NPN with M8 Connector	6003P, 8003P, 11003P	OISN-011	1-4
M8 Inductive Sensor PNP with M12 Connector	14003P, 16503P	OISP-017	1-4
M8 Inductive Sensor NPN with M12 Connector	14003P, 16503P	OISN-017	1-4
M8 Quick Disconnect 2 Meter Cable Length*	6003P, 8003P, 11003P	CABL-010	1-4
M12 Quick Disconnect 2 Meter Cable Length*	14003P, 16503P	CABL-014	1-4
Inductive Sensor Mounting Kit (1 holder, 1 flag, 2 spacers)	6003P, 8003P	SD60-80P	1-2
Inductive Sensor Mounting Kit (1 holder, 1 flag, 2 spacers)	11003P	SD110P	1-2
Inductive Sensor Mounting Kit (1 holder, 1 flag, 2 spacers)	14003P	OSMK-114	1-2
Inductive Sensor Mounting Kit (1 holder, 1 flag, 2 spacers)	16503P	OSMK-115	1-2

*Sensor and cable sold separately.

Specifications	Units	6003P-P	6003P-P-C	8003P-P	8003P-P-C	11003P-P	11003P-P-C
Grip Force (F6+R)1, 6 bar [87 psi], Springs Mid-Way, L=0	N [lbs]	678 [152]	422 [95]	1888 [424]	1219 [274]	1979 [445]	2030 [456]
Grip Force (F0+R)2, 0 bars, Springs Mid-Way, L=0	N [lbs]	172 [39]	107 [24]	617 [139]	398 [89]	628 [141]	644 [145]
Total Stroke	mm [in]	10 [0.39]	16 [0.63]	13 [0.51]	20 [0.79]	20 [0.79]	30 [1.18]
Weight	kg [lbs]	0.60 [1.32]		0.97 [2.14]		2.35 [5.18]	
Pressure Range w/o Spring	bar [psi]	2-7 [30-100]					
Pressure Range with Spring	bar [psi]	4-7 [60-100]					
Ingress Protection Class (IP)		IP54					
Displacement	cm ³ [in ³]	12 [0.73]		35 [2.14]		87 [5.31]	
Temp. Range (Buna-N seals)	°C [°F]	-35°~80° [-30°~180°]					
Temp. Range (Viton® seals)	°C [°F]	-30°~150° [-20°~300°]					
Actuation (open/close)	sec.	0.07		0.08		0.10	
Repeatability	mm [in]	±0.02 [±0.001]					

Specifications	Units	14003P-P	14003P-P-C	16503P-P	16503P-P-C
Grip Force (F6+R)1, 6 bar [87 psi], Springs Mid-Way, L=0	N [lbs]	6077 [1366]	4031 [906]	11190 [2515]	6878 [1546]
Grip Force (F0+R)2, 0 bars, Springs Mid-Way, L=0	N [lbs]	2248 [508]	1490 [335]	3730 [838]	2292 [515]
Total Stroke	mm [in]	26 [1.02]	40 [1.57]	30 [1.18]	50 [1.97]
Weight	kg [lbs]	4.7 [10.36]		9.04 [19.92]	
Pressure Range w/o Spring	bar [psi]	2-7 [30-100]			
Pressure Range with Spring	bar [psi]	4-7 [60-100]			
Ingress Protection Class (IP)		IP54			
Displacement	cm ³ [in ³]	220 [13.43]		494 [30.15]	
Temp. Range (Buna-N seals)	°C [°F]	-35°~80° [-30°~180°]			
Temp. Range (Viton® seals)	°C [°F]	-30°~150° [-20°~300°]			
Actuation (open/close)	sec.	0.16		0.29	
Repeatability	mm [in]	±0.02 [±0.001]			

6003P, 6003P-C

3-Jaw Parallel Grippers | Dimensions and Technical Specifications

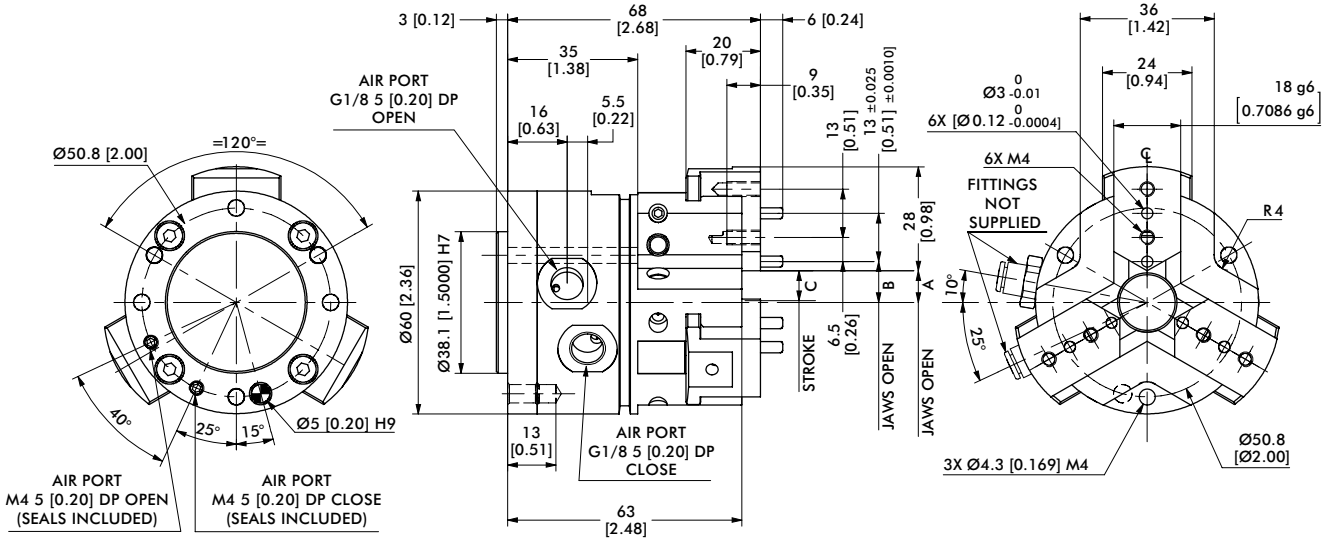

OUR GRIPPERS ARE SUPPLIED WITH OPEN SIDE AIR PORTS AND TOP AIR PORTS PLUGGED. WHEN OPERATING TOP AIR PORTS, PRODUCES MANIFOLD SEALING AS SHOWN.

GRIPPERS TOP AIR PORT
O-RING Ø1.5 X Ø4

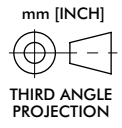

Model	A	B	C
6003P	5.5 [0.22]	8 [0.31]	5 [0.20]
6003P-C	8.5 [0.33]	11 [0.43]	8 [0.31]

Dimensions in mm [in]

Protective Boots	6003P
PVC Protective Boot, Brown or Black	ER63P
Fireproof KEVLAR Protective Boot, Red	E3R63P

Seal Repair Kits	6003P
Buna-N Seal Repair Kit	SLKT-156
Viton® Seal Repair Kit	SLKT-156V
Hydraulic Seal Repair Kit	SLKT-330

Loading Information

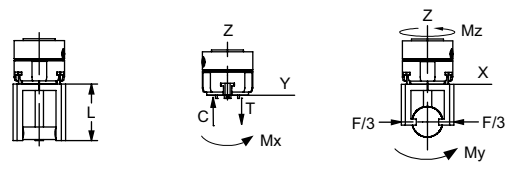
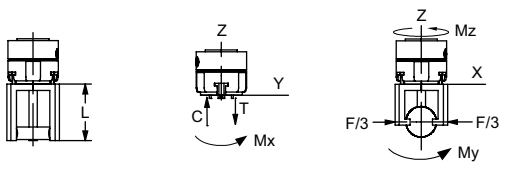
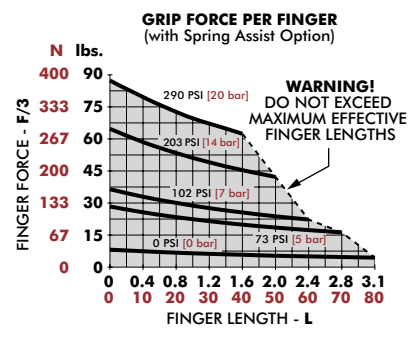
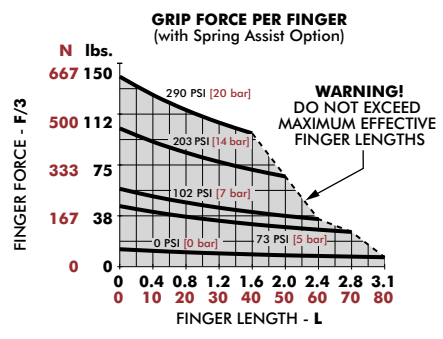

6003P	Static	Dynamic
Maximum Tensile T	819 N [184 lbs]	175 N [39 lbs]
Maximum Compressive C	1556 N [350 lbs]	175 N [39 lbs]
Maximum Moment M_x	42 Nm [372 in-lbs]	5 Nm [44 in-lbs]
Maximum Moment M_y	49 Nm [434 in-lbs]	6 Nm [53 in-lbs]
Maximum Moment M_z	54 Nm [478 in-lbs]	6 Nm [53 in-lbs]

6003P-C	Static	Dynamic
Maximum Tensile T	745 N [167 lbs]	108 N [24 lbs]
Maximum Compressive C	1415 N [318 lbs]	108 N [24 lbs]
Maximum Moment M_x	34 Nm [301 in-lbs]	3 Nm [27 in-lbs]
Maximum Moment M_y	39 Nm [345 in-lbs]	4 Nm [35 in-lbs]
Maximum Moment M_z	49 Nm [434 in-lbs]	4 Nm [35 in-lbs]

*Capacities are per set of jaws and are not simultaneous

*Capacities are per set of jaws and are not simultaneous

8003P, 8003P-C

3-Jaw Parallel Grippers | Dimensions and Technical Specifications

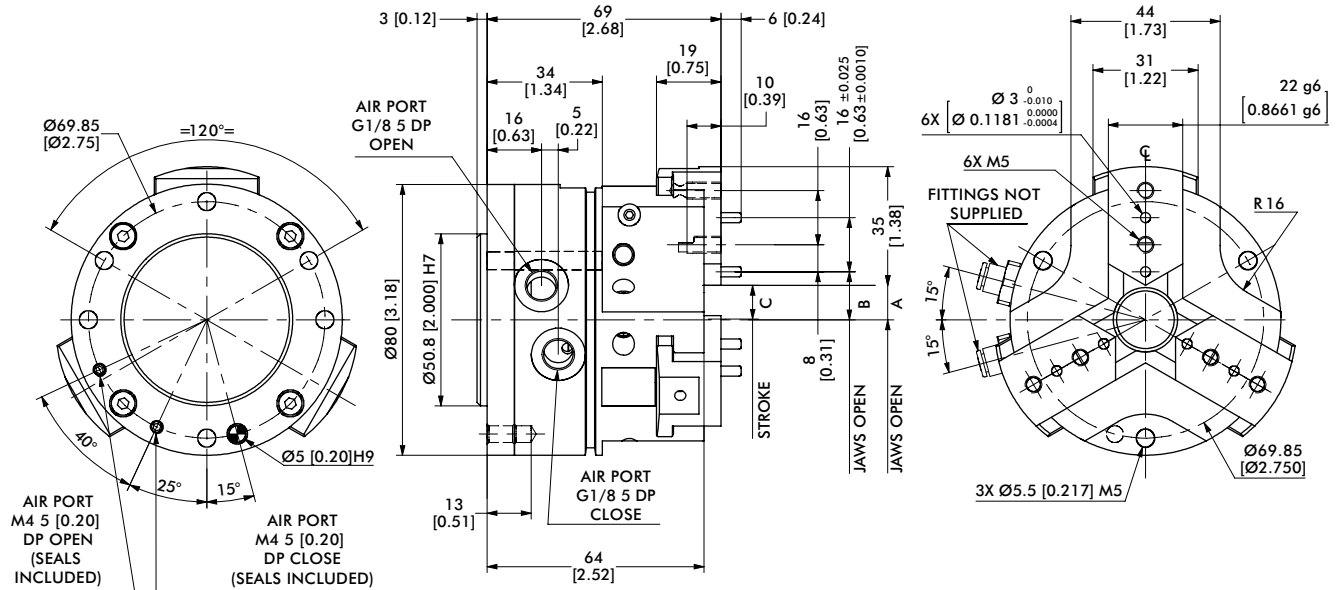

OUR GRIPPERS ARE SUPPLIED WITH OPEN SIDE AIR PORTS AND TOP AIR PORTS PLUGGED. WHEN OPERATING TOP AIR PORTS, PRODUCES MANIFOLD SEALING AS SHOWN.

GRIPPERS TOP AIR PORT
O-RING Ø1.5 X Ø4

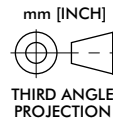

Model	A	B	C
8003P	6.8 [0.27]	10.8 [0.43]	6.5 [0.26]
8003P-C	10.2 [0.40]	14.2 [0.56]	10 [0.39]

Dimensions in mm [in]

Protective Boots	8003P
PVC Protective Boot, Brown or Black	ER83P
Fireproof KEVLAR Protective Boot, Red	E3R83P

Seal Repair Kits	8003P
Buna-N Seal Repair Kit	S80
Viton® Seal Repair Kit	S80V
Hydraulic Seal Repair Kit	S80H

Loading Information

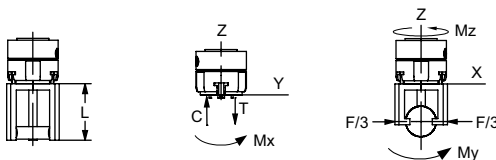
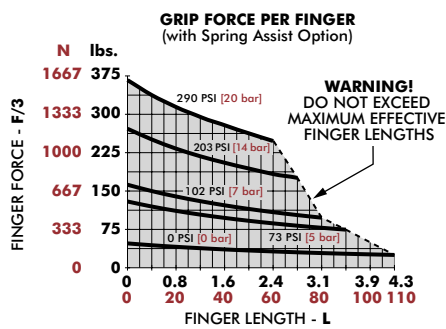

8003P	Static	Dynamic
Maximum Tensile T	1229 N [276 lbs]	436 N [98 lbs]
Maximum Compressive C	2075 N [466 lbs]	436 N [98 lbs]
Maximum Moment M_x	60 Nm [531 in-lbs]	16 Nm [142 in-lbs]
Maximum Moment M_y	68 Nm [602 in-lbs]	19 Nm [168 in-lbs]
Maximum Moment M_z	37 Nm [327 in-lbs]	19 Nm [168 in-lbs]

*Capacities are per set of jaws and are not simultaneous

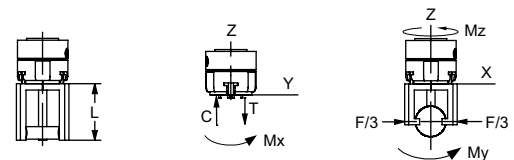
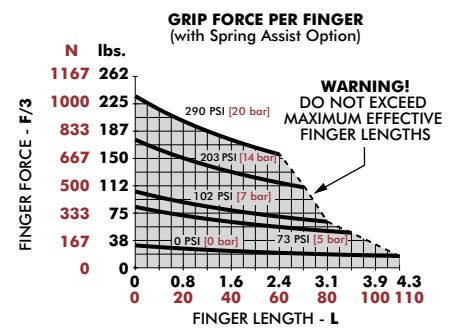

8003P-C	Static	Dynamic
Maximum Tensile T	1097 N [247 lbs]	281 N [63 lbs]
Maximum Compressive C	1853 N [416 lbs]	281 N [63 lbs]
Maximum Moment M_x	39 Nm [345 in-lbs]	12 Nm [106 in-lbs]
Maximum Moment M_y	44 Nm [389 in-lbs]	13 Nm [115 in-lbs]
Maximum Moment M_z	34 Nm [301 in-lbs]	13 Nm [115 in-lbs]

*Capacities are per set of jaws and are not simultaneous

11003P, 11003P-C

3-Jaw Parallel Grippers | Dimensions and Technical Specifications

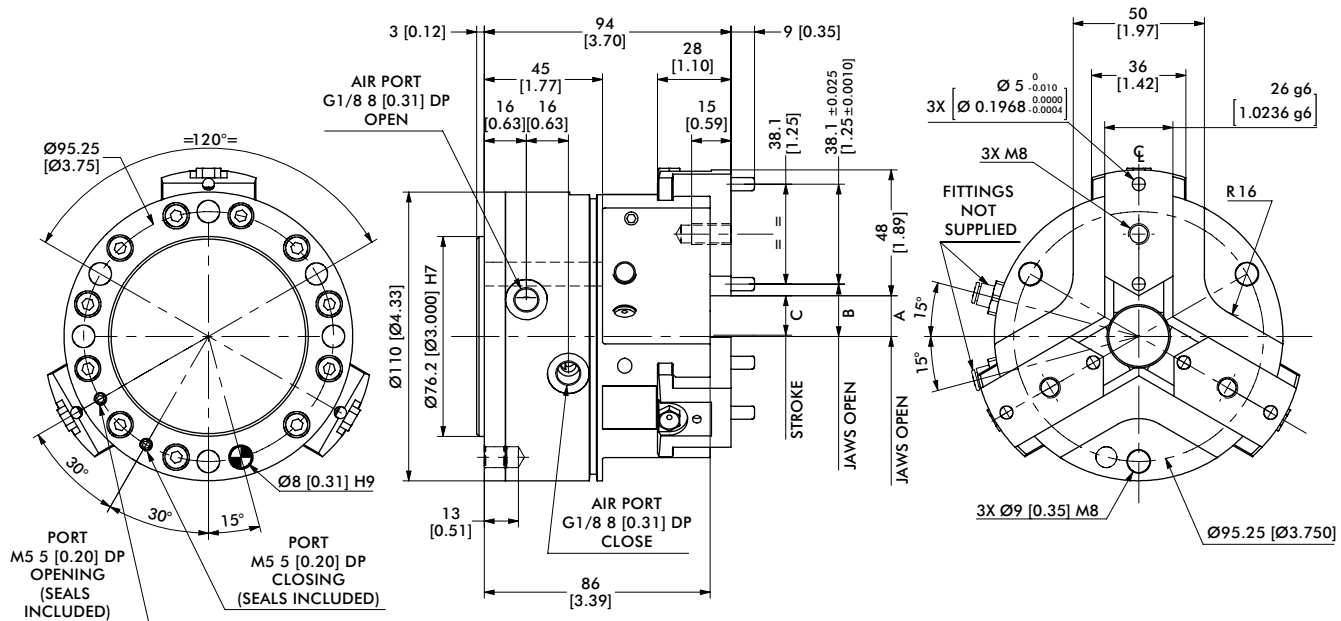

OUR GRIPPERS ARE SUPPLIED WITH OPEN SIDE AIR PORTS AND TOP AIR PORTS PLUGGED. WHEN OPERATING TOP AIR PORTS, PRODUCES MANIFOLD SEALING AS SHOWN.

GRIPPERS TOP AIR PORT

O-RING Ø1.5 X Ø5

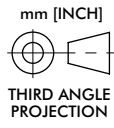

Model	A	B	C
11003P	10.5 [0.41]	15 [0.59]	10 [0.39]
11003P-C	15.5 [0.61]	20 [0.79]	15 [0.59]

Dimensions in mm [in]

Protective Boots	11003P
PVC Protective Boot, Brown or Black	ER113P
Fireproof KEVLAR Protective Boot, Red	E3R113P
Seal Repair Kits	11003P
Buna-N Seal Repair Kit	S110
Viton® Seal Repair Kit	S110V
Hydraulic Seal Repair Kit	S110H

Loading Information

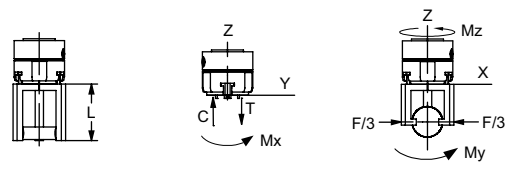
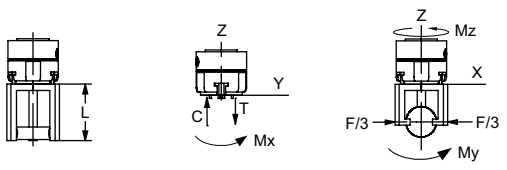
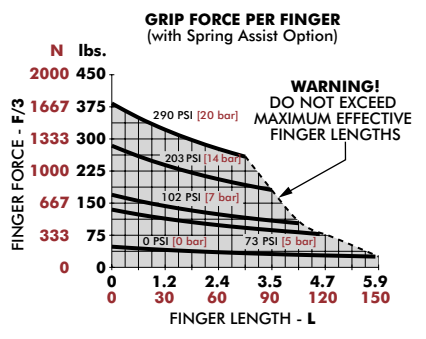
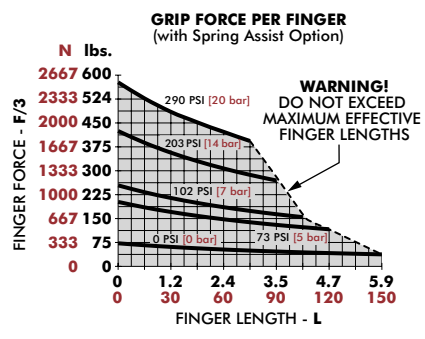

11003P	Static	Dynamic
Maximum Tensile T	1560 N [351 lbs]	695 N [156 lbs]
Maximum Compressive C	2652 N [596 lbs]	695 N [156 lbs]
Maximum Moment M_x	60 Nm [531 in-lbs]	31 Nm [274 in-lbs]
Maximum Moment M_y	80 Nm [708 in-lbs]	41 Nm [363 in-lbs]
Maximum Moment M_z	90 Nm [797 in-lbs]	41 Nm [363 in-lbs]

11003P-C	Static	Dynamic
Maximum Tensile T	1418 N [319 lbs]	463 N [104 lbs]
Maximum Compressive C	2411 N [542 lbs]	463 N [104 lbs]
Maximum Moment M_x	50 Nm [443 in-lbs]	22 Nm [195 in-lbs]
Maximum Moment M_y	66 Nm [584 in-lbs]	30 Nm [266 in-lbs]
Maximum Moment M_z	84 Nm [743 in-lbs]	30 Nm [266 in-lbs]

*Capacities are per set of jaws and are not simultaneous

*Capacities are per set of jaws and are not simultaneous

14003P, 14003P-C

3-Jaw Parallel Grippers | Dimensions and Technical Specifications

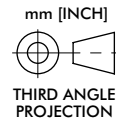
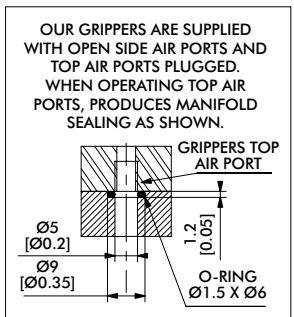
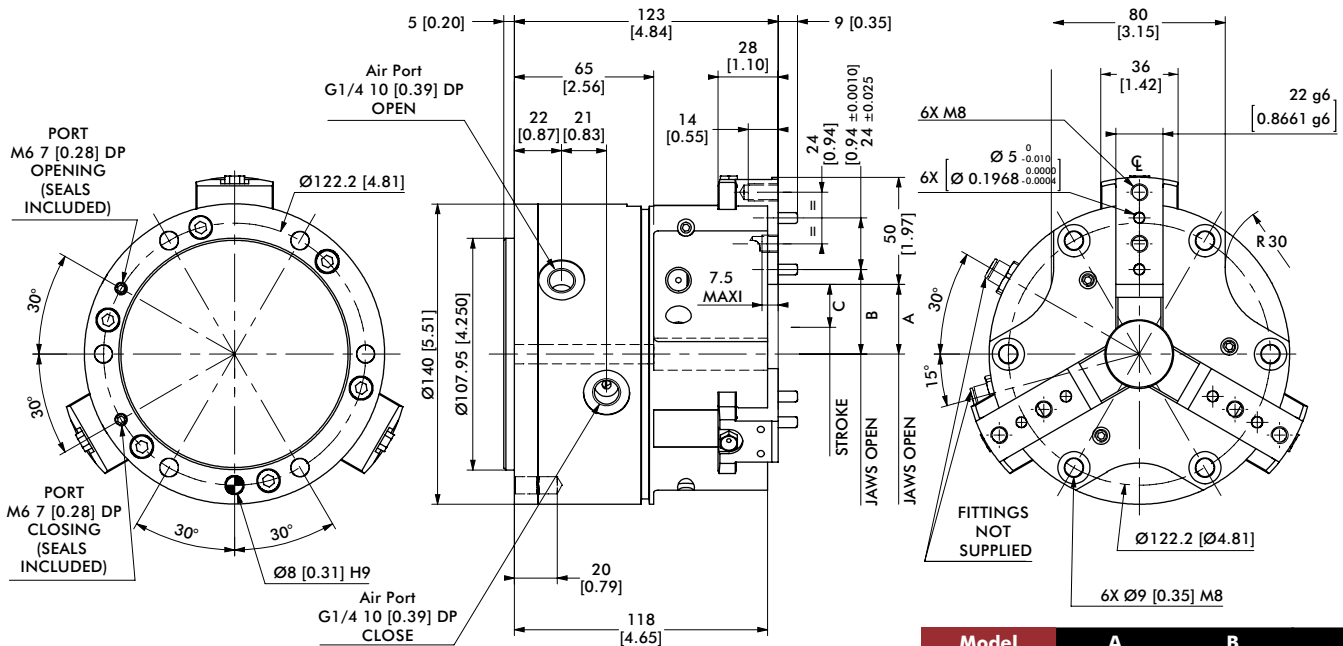

Model	A	B	C
14003P	25.5 [1.00]	32.5 [1.28]	13 [0.51]
14003P-C	32.5 [1.28]	39.5 [1.56]	20 [0.79]

Dimensions in mm [in]

Protective Boots	14003P
PVC Protective Boot, Brown or Black	KP-317
Fireproof KEVLAR Protective Boot, Red	KP-319

Seal Repair Kits	14003P
Buna-N Seal Repair Kit	SLKT-333
Viton® Seal Repair Kit	SLKT-333V
Hydraulic Seal Repair Kit	SLKT-334

Loading Information

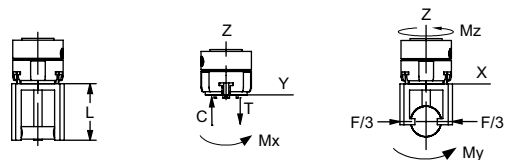
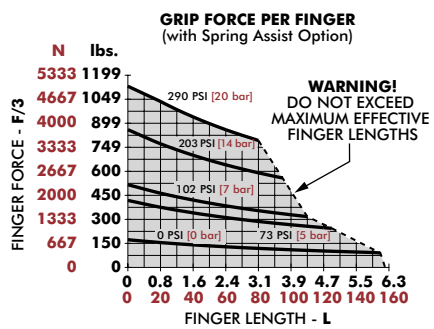

14003P	Static	Dynamic
Maximum Tensile T	2390 N [537 lbs]	850 N [191 lbs]
Maximum Compressive C	2700 N [607 lbs]	850 N [191 lbs]
Maximum Moment M_x	85 Nm [752 in-lbs]	25 Nm [221 in-lbs]
Maximum Moment M_y	130 Nm [1151 in-lbs]	40 Nm [354 in-lbs]
Maximum Moment M_z	100 Nm [885 in-lbs]	40 Nm [354 in-lbs]

*Capacities are per set of jaws and are not simultaneous

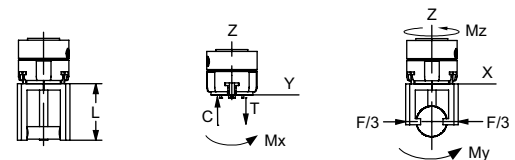
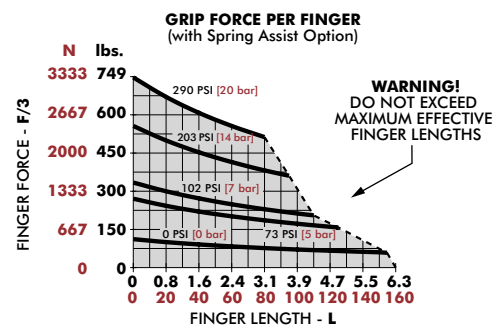

14003P-C	Static	Dynamic
Maximum Tensile T	2180 N [490 lbs]	590 N [133 lbs]
Maximum Compressive C	2500 N [562 lbs]	590 N [133 lbs]
Maximum Moment M_x	75 Nm [664 in-lbs]	20 Nm [177 in-lbs]
Maximum Moment M_y	110 Nm [974 in-lbs]	32 Nm [283 in-lbs]
Maximum Moment M_z	90 Nm [797 in-lbs]	32 Nm [283 in-lbs]

*Capacities are per set of jaws and are not simultaneous

16503P, 16503P-C

3-Jaw Parallel Grippers | Dimensions and Technical Specifications

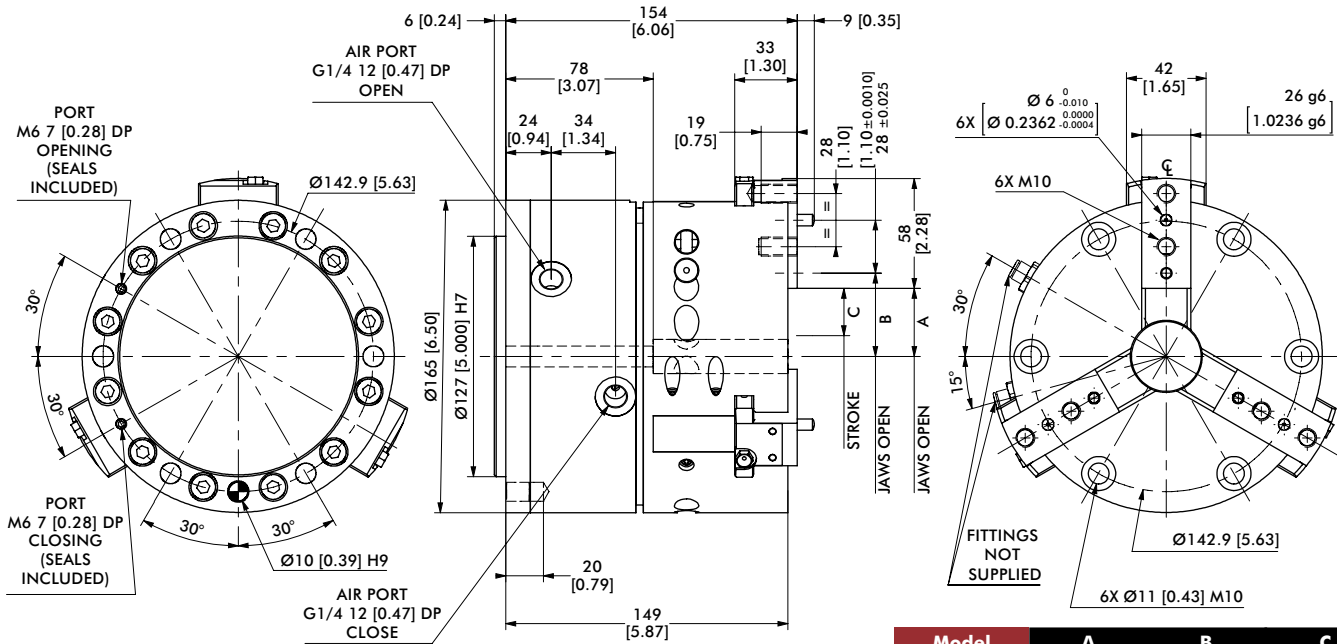

OUR GRIPPERS ARE SUPPLIED WITH OPEN SIDE AIR PORTS AND TOP AIR PORTS PLUGGED. WHEN OPERATING TOP AIR PORTS, PRODUCES MANIFOLD SEALING AS SHOWN.

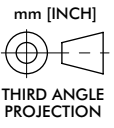

Model	A	B	C
16503P	31 [1.22]	39 [1.54]	15 [0.59]
16503P-C	36 [1.42]	44 [1.73]	25 [0.98]

Dimensions in mm [in]

Protective Boots	16503P
PVC Protective Boot, Brown or Black	KP-320
Fireproof KEVLAR Protective Boot, Red	KP-322

Seal Repair Kits	16503P
Buna-N Seal Repair Kit	SLKT-335
Viton® Seal Repair Kit	SLKT-335V
Hydraulic Seal Repair Kit	SLKT-336

Loading Information

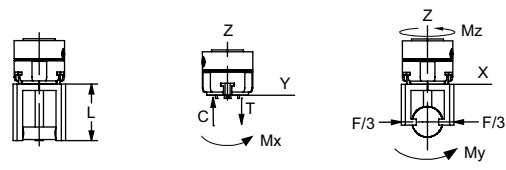
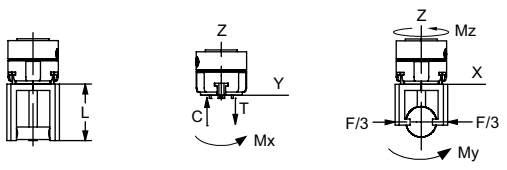
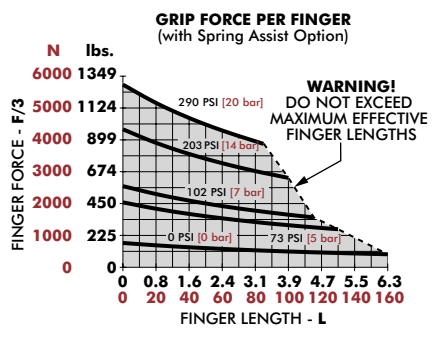
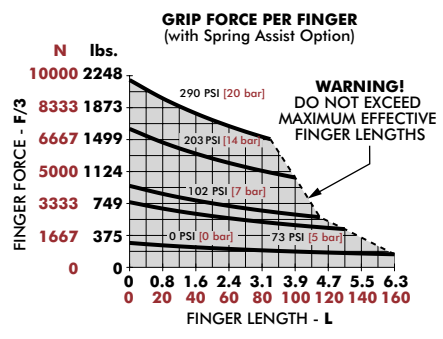

16503P	Static	Dynamic
Maximum Tensile T	2580 N [580 lbs]	980 N [220 lbs]
Maximum Compressive C	3200 N [719 lbs]	980 N [220 lbs]
Maximum Moment M_x	100 Nm [885 in-lbs]	32 Nm [283 in-lbs]
Maximum Moment M_y	150 Nm [1328 in-lbs]	50 Nm [443 in-lbs]
Maximum Moment M_z	140 Nm [1239 in-lbs]	50 Nm [443 in-lbs]

16503P-C	Static	Dynamic
Maximum Tensile T	2250 N [506 lbs]	810 N [182 lbs]
Maximum Compressive C	2800 N [629 lbs]	810 N [182 lbs]
Maximum Moment M_x	90 Nm [797 in-lbs]	28 Nm [248 in-lbs]
Maximum Moment M_y	140 Nm [1239 in-lbs]	40 Nm [354 in-lbs]
Maximum Moment M_z	130 Nm [1151 in-lbs]	40 Nm [354 in-lbs]

*Capacities are per set of jaws and are not simultaneous

*Capacities are per set of jaws and are not simultaneous

3P OPTIONS & ACCESSORIES

3-Jaw Parallel Grippers | Dimensions and Technical Specifications

SUPPLY: (P) Pneumatic (H) (H80) Hydraulic

As standard, the clamp is supplied with air to a pressure of 7 bar. On request (contact us) the gripper can be supplied with hydraulic fluid. The clamp is fitted with seals Viton Quad-Ring.

- Choice **(H)** allows a hydraulic power to a pressure of 20 bar max. In this case the overall dimensions do not change. For better security the gripper must be fixed on their support before being fired.

CAUTION: Hydraulic cycle times are longer.

The hydraulic power is incompatible with the option tandem (M).

Option (RE) or (RI): Spring Assist

The internal springs of the gripper ensures grip force is maintained by retaining the component during pressure loss, to increase the gripforce, or allows the usage of the gripper in single acting operation.

Option **(RE)** for external gripping. Option **(RI)** for internal gripping.

The (RE) is incompatible with the option (RI).

Option (T): Sensor Rod

Option **(T)** is a steel rod which comes out on the rear side of the gripper. The rod is fixed with the piston and has the same stroke movement. The open end of the rod allows for mounting a cam which allows to control the position of the jaws by using inductive sensors, micro switches, etc

WARNING: when screwing on cam rod, make sure the sensor rod does not rotate to prevent twisting of the springs of options **(RE)** or **(RI)**.

Option (T) is incompatible with option (K).

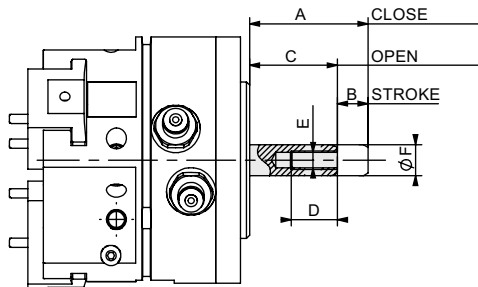

Model	A	B	C	D	E	F
6003P & 6003P-C	35	5	30	15	M6	10
8003P & 8003P-C	35	6.5	28.5	15	M6	10
11003P & 11003P-C	35	10	25	15	M6	15
14003P & 14003P-C	55	13	42	20	M8	15
16503P & 16503P-C	53	23	30	20	M8	15

Option (M): Tandem Cylinder

The **(M)** is a cylinder light-alloy that fits behind the bottom plate. This actuator's integral action allows to double the gripforce by using the same pressure. The combination of tandem option tandem **(M)** and Option **(RE)** or **(RI)** can double the clamping forces of the spring assist option. For cycle times of the tandem option, apply a factor of 3 to the actuation time.

The (M) is incompatible with the option (H).

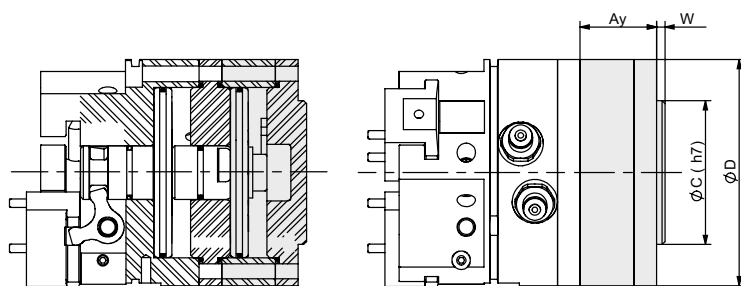

Model	Ay	ØC	ØD	W	Weight (kg)
6003P & 6003P-C	28.5	38.1	60	3	0.200
8003P & 8003P-C	27	50.8	80	3	0.300
11003P & 11003P-C	34	76.2	110	3	0.750
14003P & 14003P-C	49	107.95	140	5	2.100
16503P & 16503P-C	65	127	165	6	3.600

3P OPTIONS & ACCESSORIES

3-Jaw Parallel Grippers | Dimensions and Technical Specifications

Option (KT1), (KX1), (KT2), (KX2): Sensor Unit

The (K) is a lightweight alloy housing that fits on the back of the gripper. An integrated shaft follows the movement of the piston to provide information to the sensor attached to the side of the unit. It can control two positions of the grippers jaws. 2 types of inductive sensors (KT, KX) and 2 detection zones (1, 2) are possible to allow for the combination of 2 to 4 possible positions (KT1, KX1, KT2, KX2). For KT, KX sensor specifications.

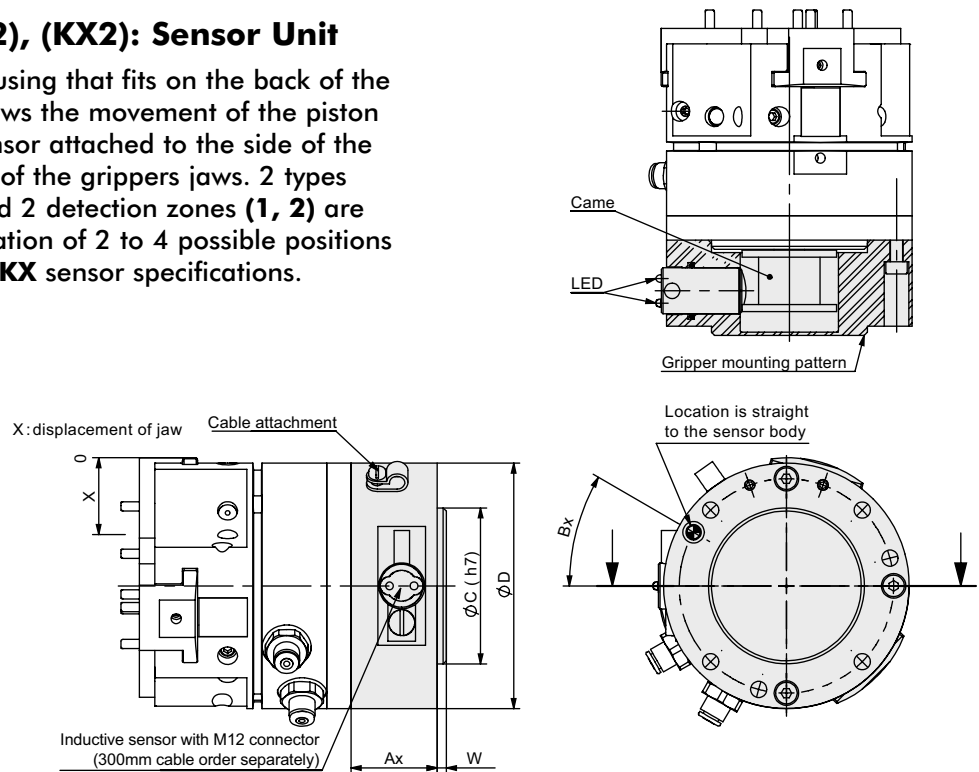

Model	Ax	Bx	ØC	ØD	W	Weight (k(g))	No. of Sensing Positions (please specify when ordering)	Information area from the open grip position (green LED) X (mm)	Area information relative to the closed grip position X (mm)
6003P	23	30°	38.1	60	3	0.180	1	0 or 1 ^{+0,5} ₋₀	4 ^{+0,5} ₋₀ or 5
							2	0 or 2 ^{+0,5} ₋₀	3 ^{+0,5} ₋₀ or 5
6003P-C	23	30°	38.1	60	3	0.180	1	0 or 1.6 ^{+0,8} ₋₀	7 ^{+0,8} ₋₀ or 8
							2	0 or 3.2 ^{+0,8} ₋₀	4.8 ^{+0,8} ₋₀ or 8
8003P	28	30°	50.8	80	3	0.400	1	0 or 1 ^{+0,5} ₋₀	5.5 ^{+0,5} ₋₀ or 6,5
							2	0 or 2 ^{+0,5} ₋₀	4.5 ^{+0,5} ₋₀ or 6,5
8003P-C	28	30°	50.8	80	3	0.400	1	0 or 1.5 ^{+0,8} ₋₀	8.5 ^{+0,8} ₋₀ or 10
							2	0 or 3.1 ^{+0,8} ₋₀	6.9 ^{+0,8} ₋₀ or 10
11003P	36	30°	76.2	110	3	0.900	1	0 or 1 ^{+0,5} ₋₀	9 ^{+0,5} ₋₀ or 10
							2	0 or 3 ^{+0,5} ₋₀	7 ^{+0,5} ₋₀ or 10
11003P-C	36	30°	76.2	110	3	0.900	1	0 or 1.5 ^{+0,8} ₋₀	13.5 ^{+0,8} ₋₀ or 15
							2	0 or 4.5 ^{+0,8} ₋₀	10.5 ^{+0,8} ₋₀ or 15
14003P	45.5	165°	107.95	140	5	1.670	1	0 or 2 ^{+0,5} ₋₀	11 ^{+0,5} ₋₀ or 13
							2	0 or 4 ^{+0,5} ₋₀	9 ^{+0,5} ₋₀ or 13
14003P-C	45.5	165°	107.95	140	5	1.670	1	0 or 3 ^{+0,8} ₋₀	17 ^{+0,8} ₋₀ or 20
							2	0 or 6.2 ^{+0,8} ₋₀	13.8 ^{+0,8} ₋₀ or 20
16003P	65.5	165°	127	165	6	2.670	1	0 or 2 ^{+0,5} ₋₀	13 ^{+0,5} ₋₀ or 15
							2	0 or 4 ^{+0,5} ₋₀	11 ^{+0,5} ₋₀ or 15
16003P-C	65.5	165°	127	165	6	2.670	1	0 or 3.3 ^{+0,8} ₋₀	21.7 ^{+0,8} ₋₀ or 25
							2	0 or 7 ^{+0,8} ₋₀	18 ^{+0,8} ₋₀ or 25

3P OPTIONS & ACCESSORIES

3-Jaw Parallel Grippers | Dimensions and Technical Specifications

Option (V): Viton® Seals

Gripper with Viton® seals allows for use in high temperature environments [-30 ° C or 150 ° C].

Accessory (E): Protective Boot

The accessory (E) is a protective boot that fits over the gripper. It protects the mechanism and thus improves the life of the gripper in hostile environments. The accessory (E) causes a different location of the fingers on the jaws as compared to the standard installation. Before attaching the boot, perform the following steps:

1. Mount gripper to machine.
2. Slip boot over gripper and secure in place.
3. Attached fingers to jaws using finger adapter.

Depending on the environment 2 types of envelopes are available:

(E) Envelope of black or brown PVC for environmental grinding with emery presence.

(E3) red envelope containing KEVLAR fireproof silicone environment for hot chips and weld spatter.

The accessory (E) is incompatible with the accessory (SD)

Model Code	Order #	Model	A	B	C	D	E	F	G	H	J	K	S	T	TX	V	Y
E	ER62P	6003P & 6003P-C	88	98	35	13.5	8	29	29	17.5	13	-	3	M4	9	13	6
E3	E3R62P																
E	ER82P	8003P & 8003P-C	89	110	34	13.5	10	33	30	22.3	16	-	3	M5	10	16	6
E3	E3R82P																
E	ER112P	11003P & 11003P-C	See Drawing														
E3	E3R112P																
E	KP-311	14003P & 14003P-C	143	185	50	18	12	55	34	19.5	24	18	5	M8	14	-	8
E3	KP-313																
E	KP-314	16003P & 16003P-C	172	220	70	16	14	67	37	24 19	28	23	6	M10	19	-	8
E3	KP-316																

6003P & 8003P

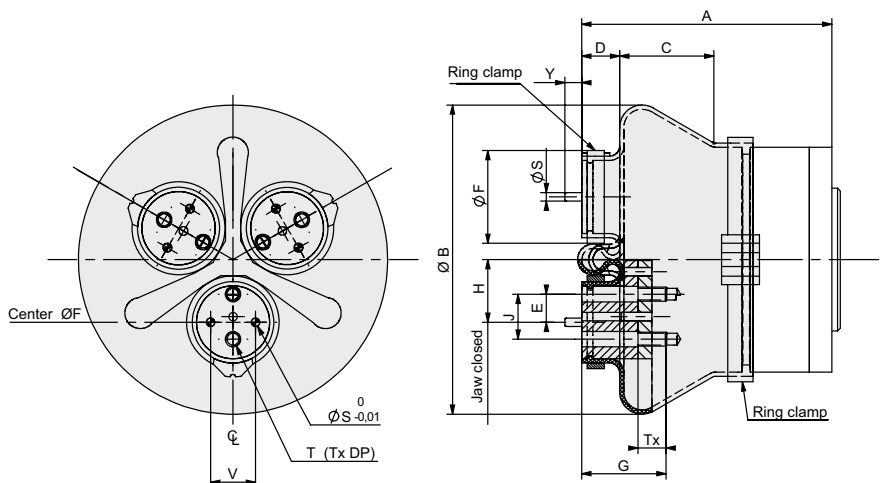

3P OPTIONS & ACCESSORIES

3-Jaw Parallel Grippers | Dimensions and Technical Specifications

11003P

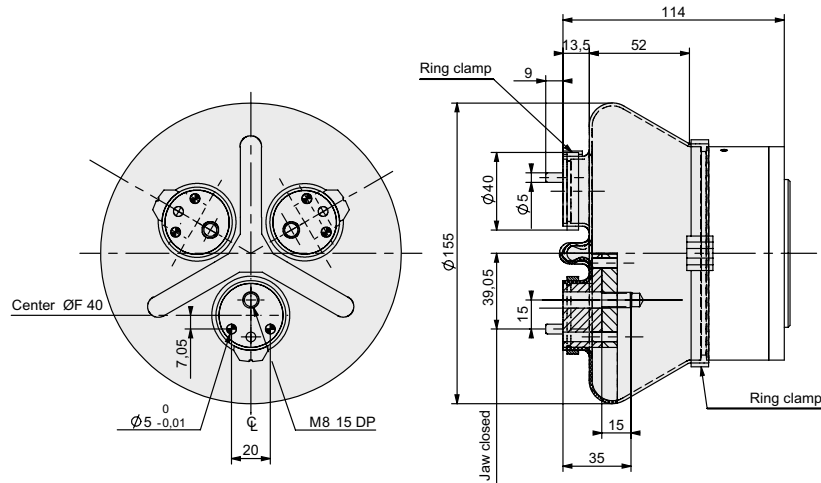

14003P & 16503P

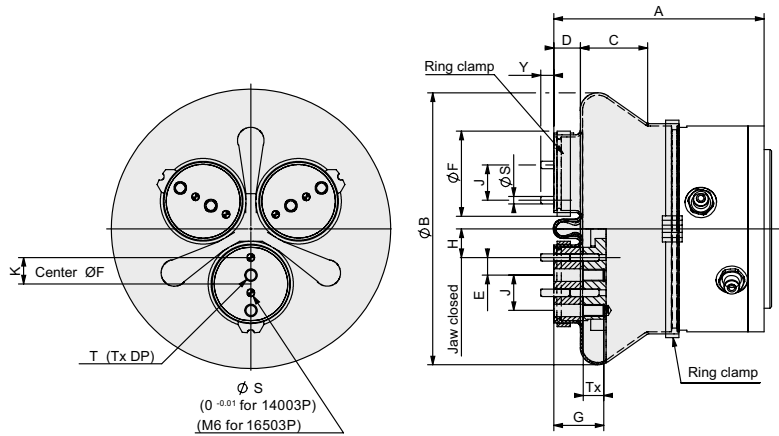

Accessory (SD): Inductive Sensor Mounting Kit

Allows for sensing of two positions: open and closed jaw. The accessory kit (SD) includes: 1 sensor bracket, 1 flag and screws. **Sensors are not provided.**

NOTES: To be usable, the cylindrical inductive sensors selected by the customer must have tapped their bodies to a minimum depth H (see table below).

Depending on their length, the cylindrical inductive sensors can extend below the clamp, requiring provision of suitable housing in the surrounding parts. It is possible to control more than 2 positions using a second attachment (SD).

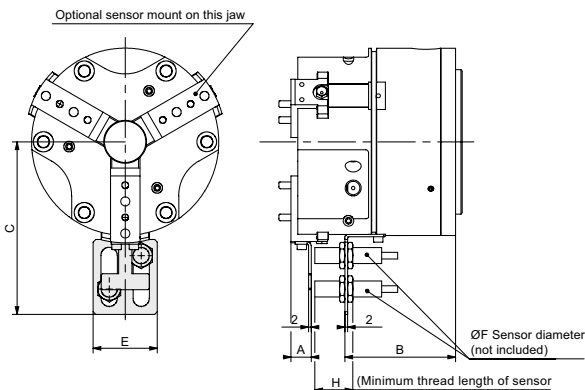

Order #	Model	A	B	C	E	F	H
SD60-80P	6003P & 6003P-C	20	35	67	32	8	35
SD60-80P	8003P & 8003P-C	19	34	77	32	8	35
SD110P	11003P & 11003P-C	19.5	45	97	32	8	35
OSMK-114	14003P & 14003P-C	15	83	129	48	12	28.5
OSMK-115	16503P & 16503P-C	29	96	147	48	12	33

RTH SERIES

3-Jaw Parallel Grippers | Features and Benefits | How To Order

Features:

- Rugged multi-purpose powerful gripper
- 8 sizes for small lightweight to very large and heavy part gripping
- High impact resistant with triple wedge design
- Shielded gripper to repel metal chips/particulates
- Spring assist option maintains grip in case of air pressure loss
- Purge and scavenge ports for harsh & clean environments
- Multi-position sensing up to 3 locations

Applications:

- Large round shaped parts
- Automotive engine block and gantry systems
- Ideal for very heavy part gripping



(USB key shown for scale)

How To Order

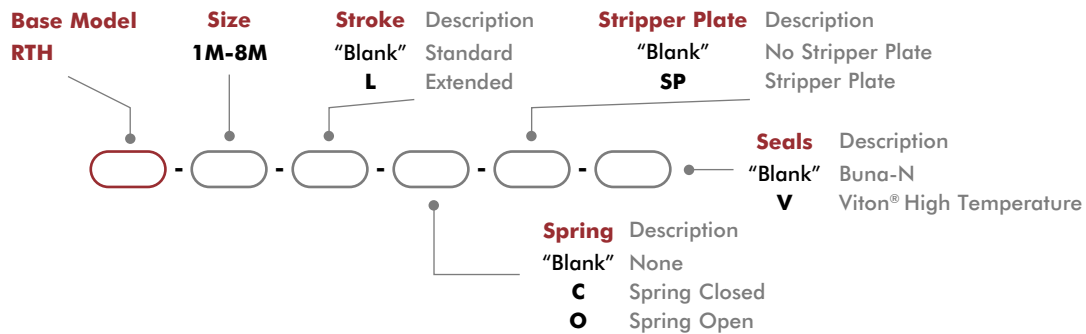

Accessories

Sensor Accessories	Model Numbers	Part Number	Qty/Unit
8mm PNP Magneto Resistive Sensor (90° barrel) w/ M8 Qk. Disc*	All Models	OHSP-011	1-3 [†]
8mm NPN Magneto Resistive Sensor (90° barrel) w/ M8 Qk. Disc*	All Models	OHSN-011	1-3 [†]
8mm PNP Magneto Resistive Sensor Short Barrel w/ M8 Qk Disc*	All Models	OHSP-017	1-3 [†]
8mm NPN Magneto Resistive Sensor Short Barrel w/ M8 Qk Disc*	All Models	OHSN-017	1-3 [†]
8mm PNP Inductive Sensor w/ M12 Quick Disconnect*	RTH-4M, -5M, -6M	OISP-011	1-3
8mm NPN Inductive Sensor w/ M12 Quick Disconnect*	RTH-4M, -5M, -6M	OISN-011	1-3
12mm PNP Inductive Sensor w/ M12 Quick Disconnect*	RTH-7M, -8M	OISP-017	1-3
12mm NPN Inductive Sensor w/ M12 Quick Disconnect*	RTH-7M, -8M	OISN-017	1-3
M8 Quick Disconnect 2 Meter Cable Length*	All Models	CABL-010	1-3
M8 Quick Disconnect 5 Meter Cable Length*	All Models	CABL-013	1-3
M12 Quick Disconnect 2 Meter Cable Length*	RTH-7M, -8M	CABL-014	1-3 [†]
M12 Quick Disconnect 5 Meter Cable Length*	RTH-7M, -8M	CABL-018	1-3 [†]

Pneumatic Accessories	Model Numbers	Part Number	Qty/Unit
M5 Adjustable Flow Control	RTH-1M, -2M, -3M	VLVF-008	1-2
G 1/8" 90° Adjustable Flow Control	RTH-4M, -5M, -6M, -7M	VLVF-005	1-2
G 1/4" Adjustable Flow Control	RDH-8M	VLVF-010	1-2

* Sensor and cable sold separately. [†] Except RTH-1, 1-2 only.

3-Jaw Heavy-Duty Parallel Grippers | Technical Specifications

Specifications	Units	1M	1M-L	2M	2M-L	3M	3M-L	4M	4M-L
Total Rated Grip Force F @ 100 psi [7 bar] w/o Spring Assist	N [lbs]	682 [153]	443 [100]	1238 [278]	812 [183]	2078 [467]	1349 [303]	3644 [819]	2366 [532]
Total Rated Grip Force F @ 100 psi [7 bar] with Spring Assist	N [lbs]	889 [200]	579 [130]	1490 [335]	979 [220]	2627 [591]	1708 [384]	4562 [1026]	2967 [667]
Total Stroke	mm [in]	4 [0.16]	8 [0.32]	6 [0.24]	12 [0.47]	8 [0.31]	16 [0.63]	10 [0.39]	20 [0.79]
Weight	kg [lbs]	0.25 [0.6]		0.53 [1.2]		1.08 [2.4]		1.95 [4.3]	
Pressure Range w/o Spring	bar [psi]	2-7 [30-100]							
Pressure Range with Spring	bar [psi]	4-7 [60-100]				3.5-7 [50-100]		3-7 [45-100]	
Max. Vacuum for Scavenge Port	mm Hg [in Hg]	200 [8]							
Max. Pressure for Purge Port	bar [psi]	2.1 [30]							
Ingress Protection Class (IP)		IP55							
Displacement	cm ³ [in ³]	6.5 [0.40]		17 [1.05]		37 [2.30]		80 [4.90]	
Temperature Range (Buna-N seals)	°C [°F]	-35°~80° [-30°~180°]							
Temperature Range (Viton® seals)	°C [°F]	-30°~150° [-20°~300°]							
Actuation (open/close)	sec.	0.06		0.07		0.08		0.1	
Accuracy	mm [in]	±0.04 [±0.002]				±0.06 [±0.0024]		±0.03 [±0.0012]	
Repeatability	mm [in]	±0.02 [±0.001]				±0.03 [±0.0012]		±0.04 [±0.0016]	
Valve to Actuate Single Acting		3-way, 2-position							
Valve to Actuate Double Acting		4-way, 2-position							

Specifications (cont.)	Units	5M	5M-L	6M	6M-L	7M	7M-L	8M	8M-L
Total Rated Grip Force F @ 100 psi [7 bar] w/o Spring Assist	N [lbs]	6353 [1428]	4125 [927]	10202 [2294]	6629 [1490]	17165 [3859]	11102 [2496]	35288 [7933]	22784 [5122]
Total Rated Grip Force F @ 100 psi [7 bar] with Spring Assist	N [lbs]	7877 [1771]	5124 [1152]	13786 [3099]	8971 [2017]	22093 [4967]	14322 [3222]	44354 [9971]	28690 [6450]
Total Stroke	mm [in]	13 [0.51]	26 [1.02]	16 [0.63]	32 [1.26]	25 [0.98]	50 [1.97]	35 [1.38]	70 [2.76]
Weight	kg [lbs]	3.9 [8.6]		7.89 [17.4]		15.7 [34.6]		43.9 [96.8]	
Pressure Range w/o Spring	bar [psi]	2-7 [30-100]							
Pressure Range with Spring	bar [psi]	3-7 [45-100]		4-7 [55-100]				3.5-7 [50-100]	
Max. Vacuum for Scavenge Port	mm Hg [in Hg]	20 [8]							
Max. Pressure for Purge Port	bar [psi]	2.1 [30]							
Ingress Protection Class (IP)		IP55							
Displacement	cm ³ [in ³]	180 [11.0]		355 [22]		940 [57]		2720 [166]	
Temperature Range (Buna-N seals)	°C [°F]	-35°~80° [-30°~180°]							
Temperature Range (Viton® seals)	°C [°F]	-30°~150° [-20°~300°]							
Actuation (open/close)	sec.	0.19		0.236		0.85		1.7	
Accuracy	mm [in]	±0.06 [±0.0024]		±0.08 [±0.0031]		±0.1 [±0.0039]		±0.05 [±0.002]	
Repeatability	mm [in]	±0.03 [±0.0012]		±0.04 [±0.0016]		±0.05 [±0.002]		±0.06 [±0.0024]	
Valve to Actuate Single Acting		3-way, 2-position							
Valve to Actuate Double Acting		4-way, 2-position							

RTH-1M, -1M-L

3-Jaw Parallel Grippers | Dimensions and Technical Specifications

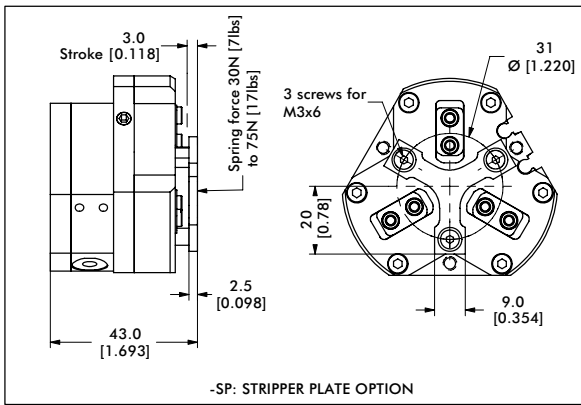
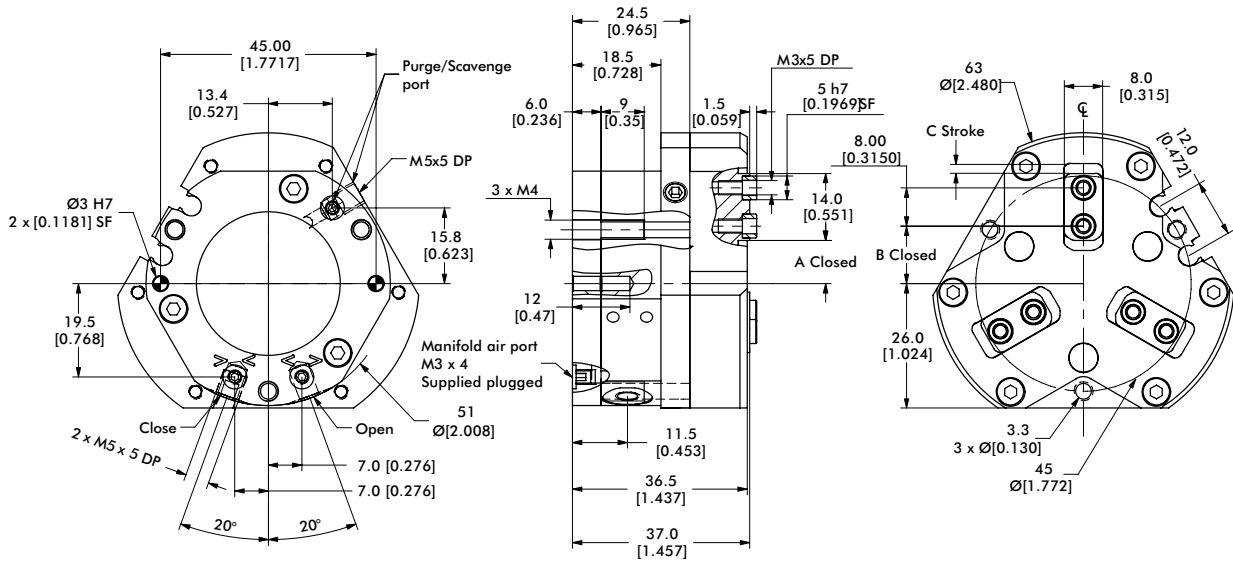

mm [INCH]

 THIRD ANGLE PROJECTION

Model	A	B	C
RTH-1M	9.0 [0.354]	12.0 [0.472]	2.0 [0.08]
RTH-1M-L	7.0 [0.276]	10.0 [0.394]	4.1 [0.16]

Dimensions in mm [in]

Seal Repair Kits	RTH-1M
Buna-N Seal Repair Kit	SLKT-347
Buna-N Rear Inlet Seal Repair Kit	SLKT-363
Viton® Seal Repair Kit	SLKT-347V
Viton® Rear Inlet Seal Repair Kit	SLKT-363V

Loading Information

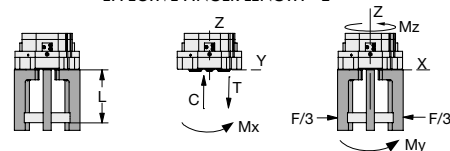
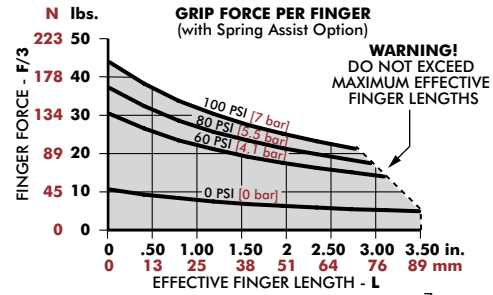
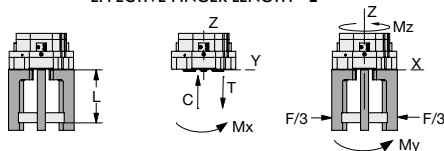
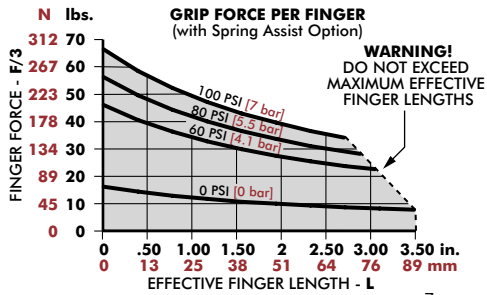

RTH-1M	Static	Dynamic
Maximum Tensile T	810 N [182 lbs]	89 N [20 lbs]
Maximum Compressive C	1060 N [238 lbs]	89 N [20 lbs]
Maximum Moment M_x	22 Nm [195 in-lbs]	2 Nm [18 in-lbs]
Maximum Moment M_y	28 Nm [248 in-lbs]	3 Nm [27 in-lbs]
Maximum Moment M_z	18 Nm [159 in-lbs]	3 Nm [27 in-lbs]

[†]Capacities are per set of jaws and are not simultaneous

RTH-1M-L	Static	Dynamic
Maximum Tensile T	730 N [164 lbs]	57 N [13 lbs]
Maximum Compressive C	960 N [216 lbs]	57 N [13 lbs]
Maximum Moment M_x	20 Nm [177 in-lbs]	1 Nm [9 in-lbs]
Maximum Moment M_y	23 Nm [204 in-lbs]	1 Nm [9 in-lbs]
Maximum Moment M_z	15 Nm [133 in-lbs]	1 Nm [9 in-lbs]

[†]Capacities are per set of jaws and are not simultaneous

RTH-2M, -2M-L

3-Jaw Parallel Grippers | Dimensions and Technical Specifications

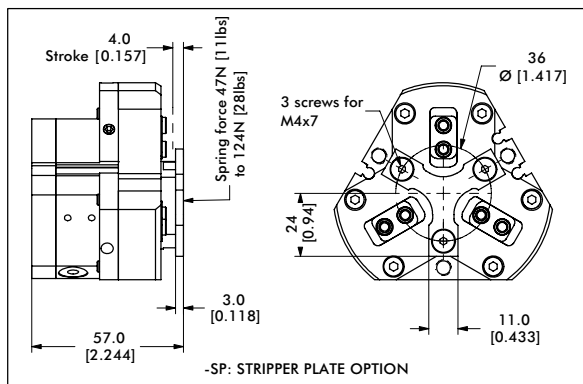
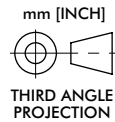
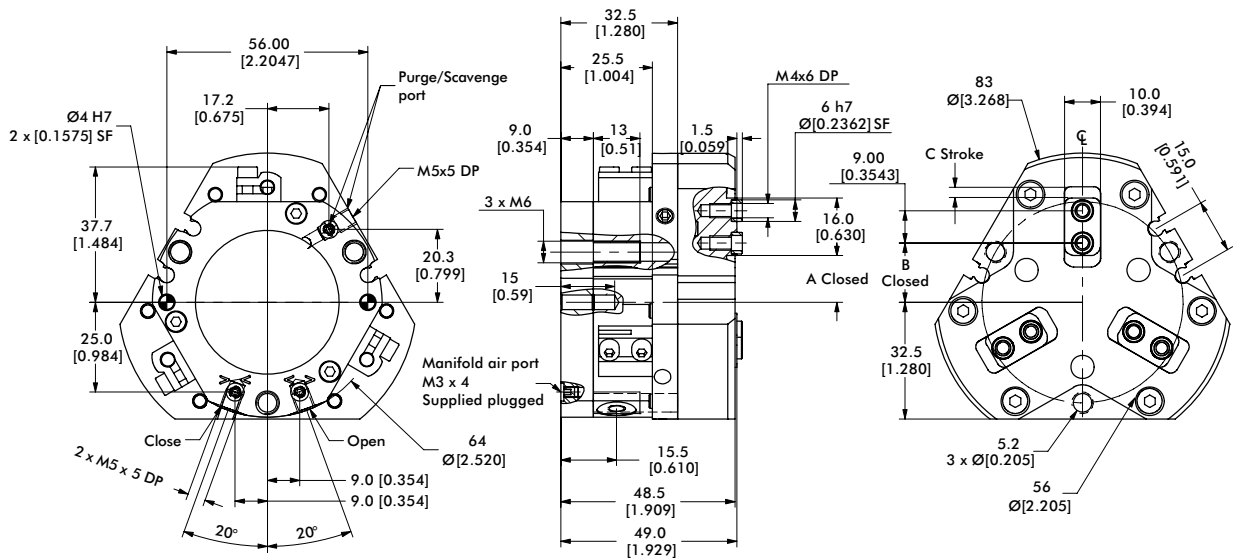

Model	A	B	C
RTH-2M	13.0 [0.512]	16.5 [0.650]	3.0 [0.12]
RTH-2M-L	10.0 [0.394]	13.5 [0.531]	6.0 [0.24]

Dimensions in mm [in]

Seal Repair Kits	RTH-2M
Buna-N Seal Repair Kit	SLKT-348
Buna-N Rear Inlet Seal Repair Kit	SLKT-363
Viton® Seal Repair Kit	SLKT-4348V
Viton® Rear Inlet Seal Repair Kit	SLKT-363V

Loading Information

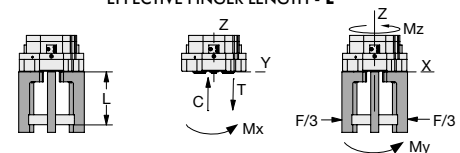
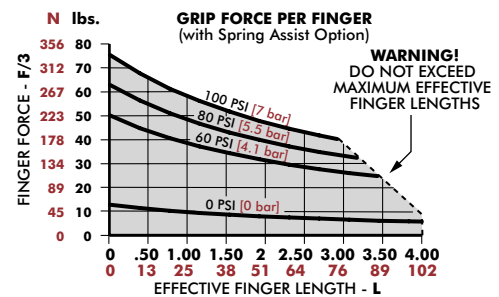
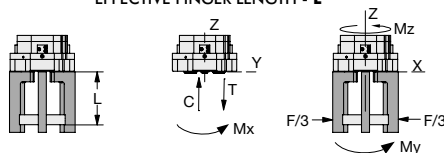
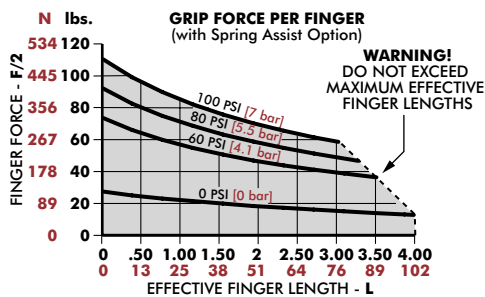

RTH-2M	Static	Dynamic
Maximum Tensile T	1200 N [270 lbs]	129 N [29 lbs]
Maximum Compressive C	1560 N [351 lbs]	129 N [29 lbs]
Maximum Moment M_x	45 Nm [398 in-lbs]	4 Nm [35 in-lbs]
Maximum Moment M_y	64 Nm [566 in-lbs]	6 Nm [53 in-lbs]
Maximum Moment M_z	41 Nm [363 in-lbs]	6 Nm [53 in-lbs]

*Capacities are per set of jaws and are not simultaneous

RTH-2M-L	Static	Dynamic
Maximum Tensile T	1080 N [243 lbs]	84 N [19 lbs]
Maximum Compressive C	1400 N [315 lbs]	84 N [19 lbs]
Maximum Moment M_x	40 Nm [354 in-lbs]	3 Nm [27 in-lbs]
Maximum Moment M_y	52 Nm [460 in-lbs]	4 Nm [35 in-lbs]
Maximum Moment M_z	33 Nm [292 in-lbs]	4 Nm [35 in-lbs]

*Capacities are per set of jaws and are not simultaneous

RTH-3M, -3M-L

3-Jaw Parallel Grippers | Dimensions and Technical Specifications

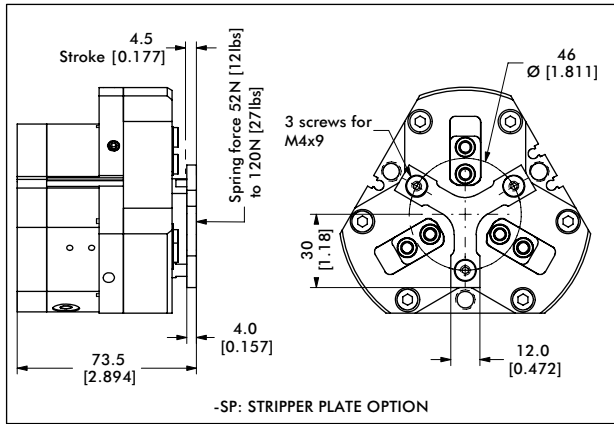
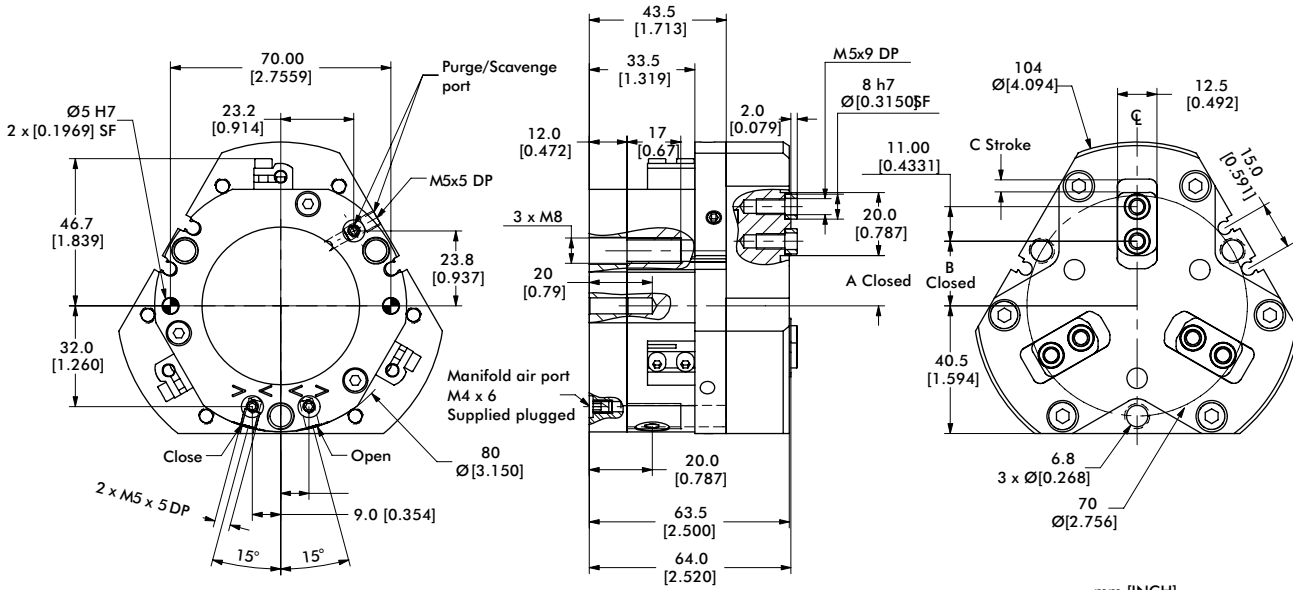

mm [INCH]

 THIRD ANGLE PROJECTION

Model	A	B	C
RTH-3M	16.0 [0.630]	20.5 [0.807]	3.9 [0.16]
RTH-3M-L	12.0 [0.742]	16.5 [0.650]	8.0 [0.32]

Dimensions in mm [in]

Seal Repair Kits	RTH-3M
Buna-N Seal Repair Kit	SLKT-349
Buna-N Rear Inlet Seal Repair Kit	SLKT-364
Viton® Seal Repair Kit	SLKT-349V
Viton® Rear Inlet Seal Repair Kit	SLKT-364V

Loading Information

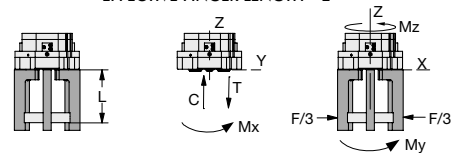
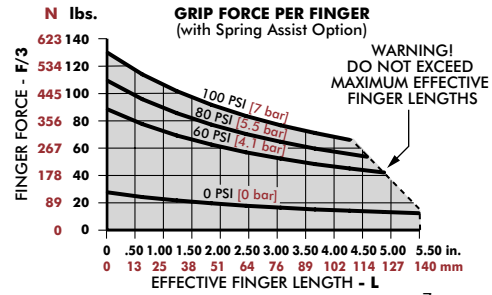
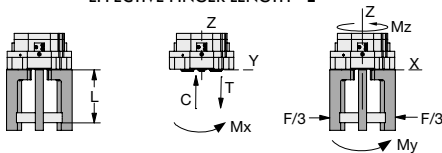
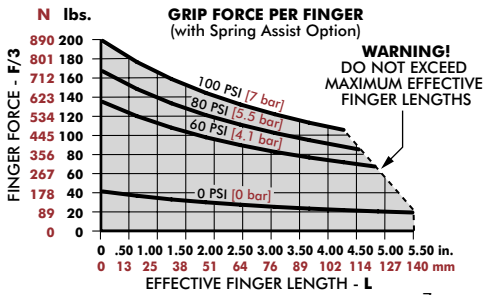

RTH-3M	Static	Dynamic
Maximum Tensile T	1680 N [378 lbs]	302 N [68 lbs]
Maximum Compressive C	2180 N [490 lbs]	302 N [68 lbs]
Maximum Moment M_x	72 Nm [637 in-lbs]	11 Nm [97 in-lbs]
Maximum Moment M_y	102 Nm [903 in-lbs]	16 Nm [142 in-lbs]
Maximum Moment M_z	66 Nm [584 in-lbs]	16 Nm [142 in-lbs]

[†]Capacities are per set of jaws and are not simultaneous

RTH-3M-L	Static	Dynamic
Maximum Tensile T	1500 N [337 lbs]	197 N [44 lbs]
Maximum Compressive C	1940 N [436 lbs]	197 N [44 lbs]
Maximum Moment M_x	64 Nm [566 in-lbs]	7 Nm [62 in-lbs]
Maximum Moment M_y	81 Nm [717 in-lbs]	9 Nm [80 in-lbs]
Maximum Moment M_z	53 Nm [469 in-lbs]	9 Nm [80 in-lbs]

[†]Capacities are per set of jaws and are not simultaneous

RTH-4M, -4M-L

3-Jaw Parallel Grippers | Dimensions and Technical Specifications

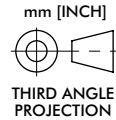
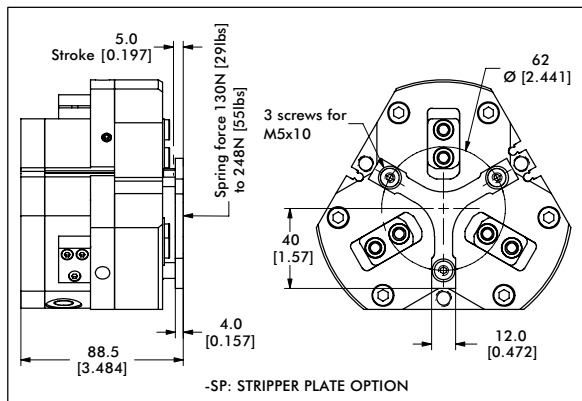
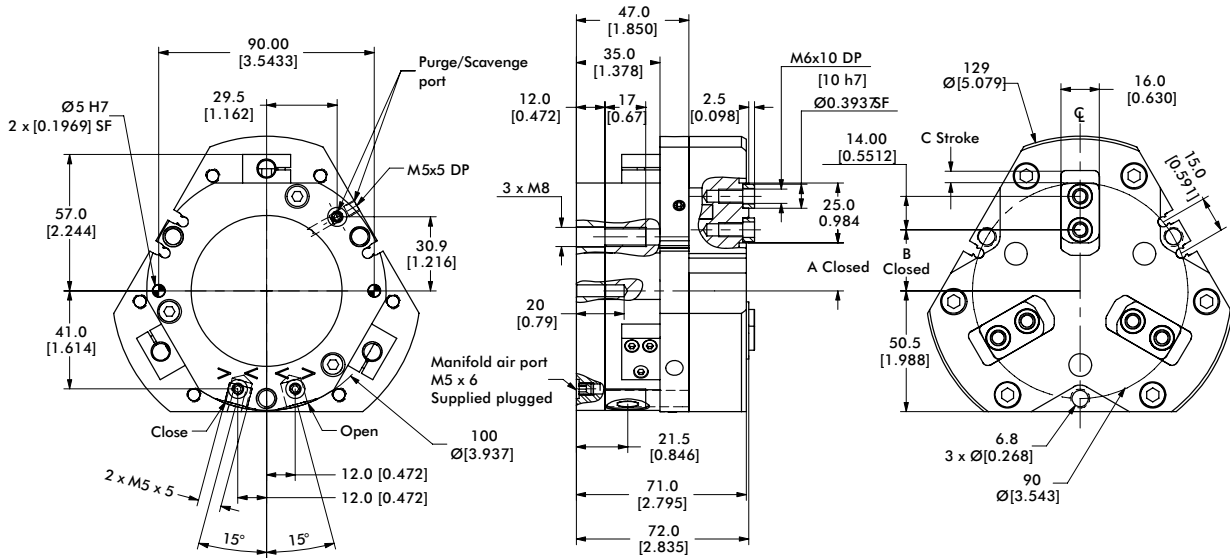

Model	A	B	C
RTH-4M	20.0 [0.787]	25.5 [1.004]	5.0 [0.20]
RTH-4M-L	15.0 [0.591]	20.5 [0.807]	10.0 [0.40]

Dimensions in mm [in]

Seal Repair Kits	RTH-4M
Buna-N Seal Repair Kit	SLKT-350
Buna-N Rear Inlet Seal Repair Kit	SLKT-365
Viton® Seal Repair Kit	SLKT-350V
Viton® Rear Inlet Seal Repair Kit	SLKT-365V

Loading Information

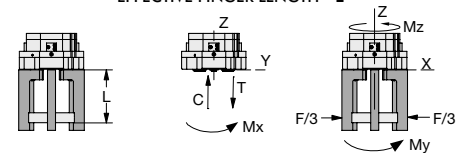
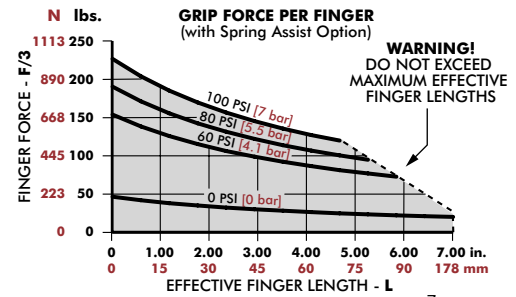
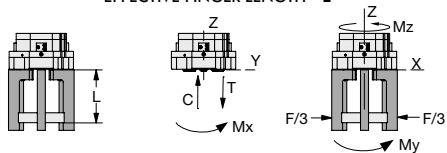
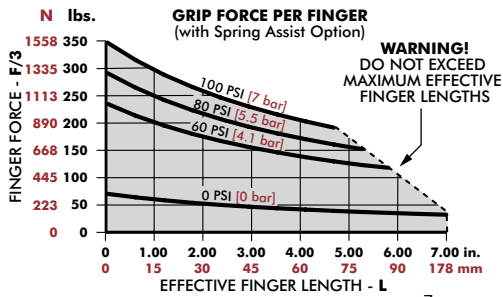

RTH-4M	Static	Dynamic
Maximum Tensile T	2110 N [474 lbs]	425 N [96 lbs]
Maximum Compressive C	2790 N [627 lbs]	425 N [96 lbs]
Maximum Moment M_x	92 Nm [814 in-lbs]	16 Nm [142 in-lbs]
Maximum Moment M_y	182 Nm [1133 in-lbs]	22 Nm [195 in-lbs]
Maximum Moment M_z	84 Nm [734 in-lbs]	22 Nm [195 in-lbs]

*Capacities are per set of jaws and are not simultaneous

RTH-4M-L	Static	Dynamic
Maximum Tensile T	1880 N [423 lbs]	275 N [62 lbs]
Maximum Compressive C	2490 N [560 lbs]	275 N [62 lbs]
Maximum Moment M_x	82 Nm [726 in-lbs]	10 Nm [89 in-lbs]
Maximum Moment M_y	102 Nm [903 in-lbs]	13 Nm [115 in-lbs]
Maximum Moment M_z	67 Nm [593 in-lbs]	13 Nm [115 in-lbs]

*Capacities are per set of jaws and are not simultaneous

RTH-5M, -5M-L

3-Jaw Parallel Grippers | Dimensions and Technical Specifications

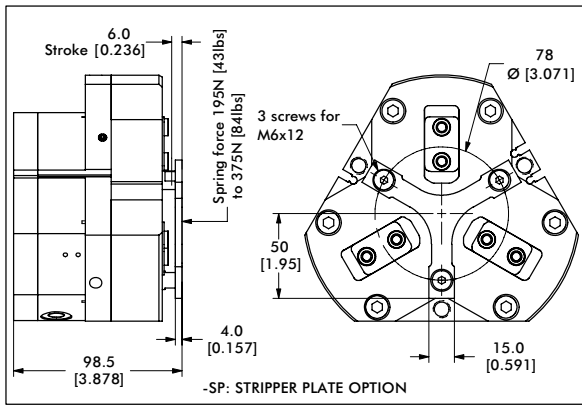
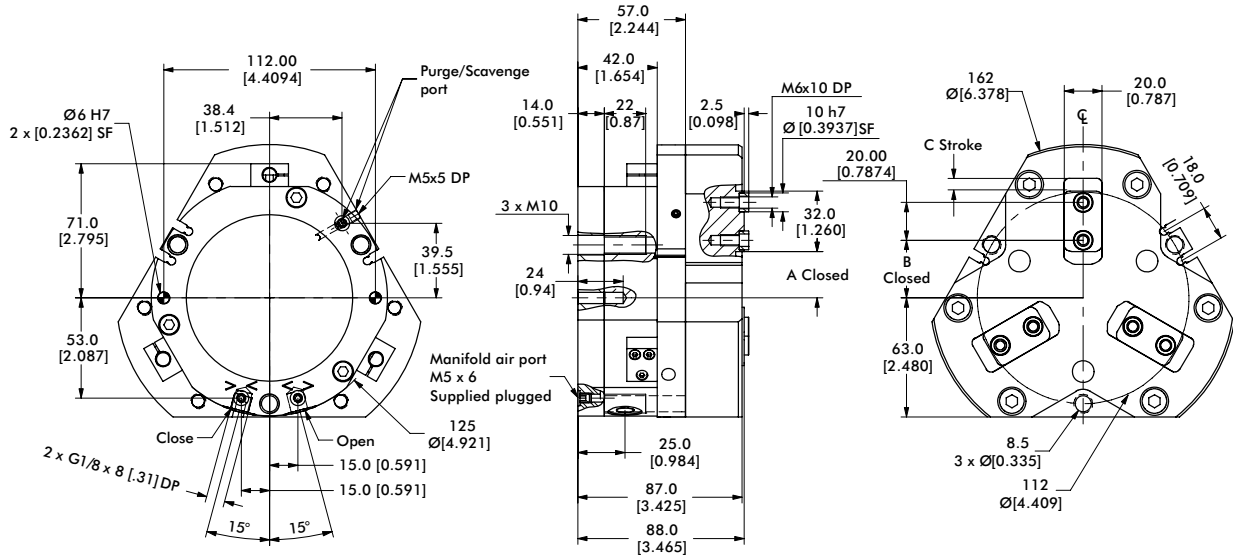

mm [INCH]

 THIRD ANGLE PROJECTION

Model	A	B	C
RTH-5M	24.5 [0.965]	30.5 [1.201]	6.5 [0.26]
RTH-5M-L	18.0 [0.709]	24.0 [0.945]	13.0 [0.51]

Dimensions in mm [in]

Seal Repair Kits	RTH-5 M
Buna-N Seal Repair Kit	SLKT-351
Buna-N Rear Inlet Seal Repair Kit	SLKT-365
Viton® Seal Repair Kit	SLKT-351V
Viton® Rear Inlet Seal Repair Kit	SLKT-365V

Loading Information

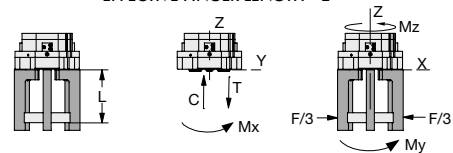
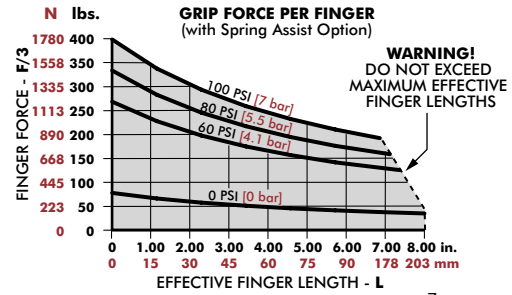
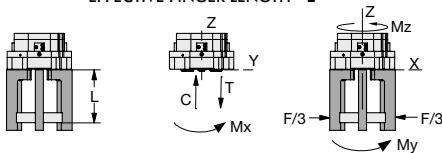
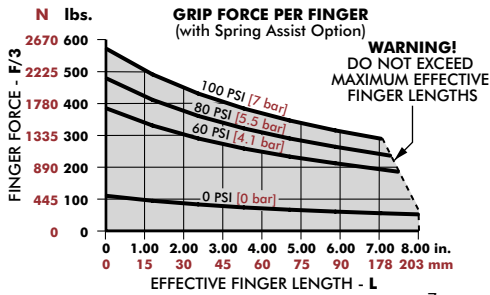

RTH-5M	Static	Dynamic
Maximum Tensile T	2990 N [672 lbs]	674 N [152 lbs]
Maximum Compressive C	3980 N [895 lbs]	674 N [152 lbs]
Maximum Moment M_x	127 Nm [1124 in-lbs]	25 Nm [221 in-lbs]
Maximum Moment M_y	179 Nm [1584 in-lbs]	35 Nm [310 in-lbs]
Maximum Moment M_z	117 Nm [1036 in-lbs]	35 Nm [310 in-lbs]

*Capacities are per set of jaws and are not simultaneous

RTH-5M-L	Static	Dynamic
Maximum Tensile T	2680 N [602 lbs]	432 N [97 lbs]
Maximum Compressive C	3570 N [803 lbs]	432 N [97 lbs]
Maximum Moment M_x	114 Nm [1009 in-lbs]	16 Nm [142 in-lbs]
Maximum Moment M_y	144 Nm [1275 in-lbs]	20 Nm [177 in-lbs]
Maximum Moment M_z	94 Nm [832 in-lbs]	20 Nm [177 in-lbs]

*Capacities are per set of jaws and are not simultaneous

RTH-6M, -6M-L

3-Jaw Parallel Grippers | Dimensions and Technical Specifications

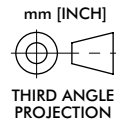
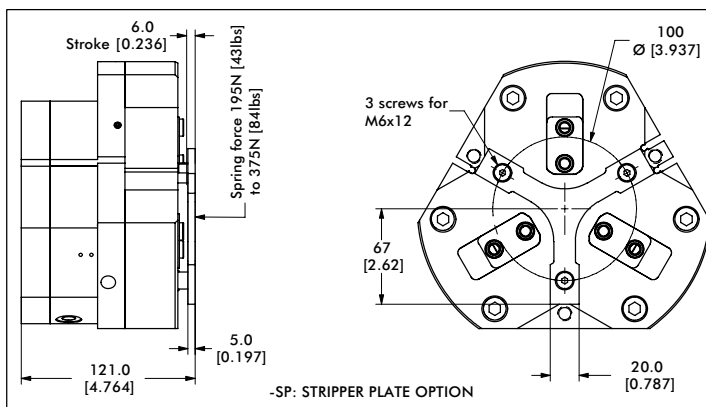
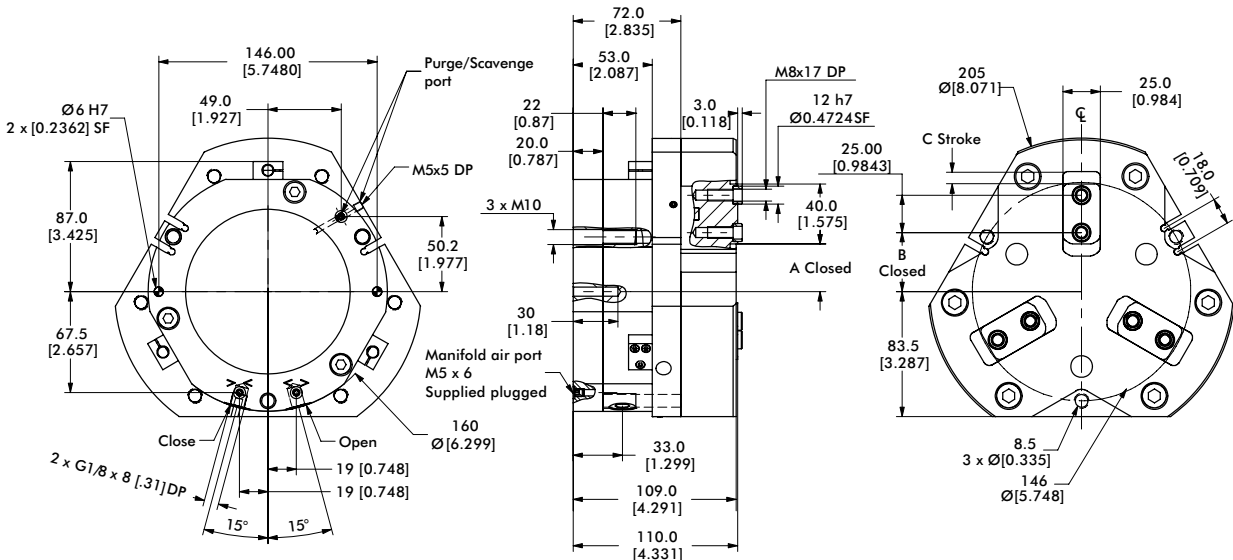

Model	A	B	C
RTH-6M	32.0 [1.260]	39.5 [1.555]	8.0 [0.32]
RTH-6M-L	24.0 [0.945]	31.5 [1.240]	16.0 [0.63]

Dimensions in mm [in]

Seal Repair Kits	RTH-6M
Buna-N Seal Repair Kit	SLKT-352
Buna-N Rear Inlet Seal Repair Kit	SLKT-365
Viton® Seal Repair Kit	SLKT-352V
Viton® Rear Inlet Seal Repair Kit	SLKT-365V

Loading Information

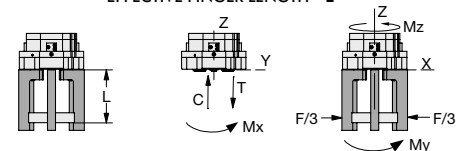
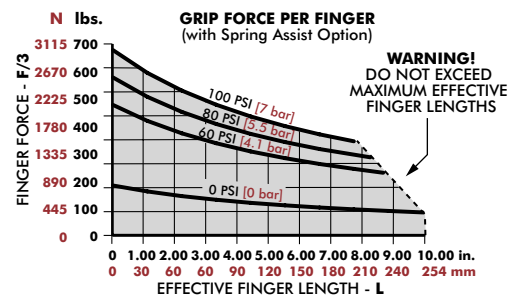
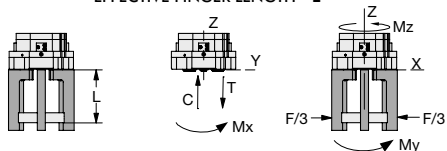
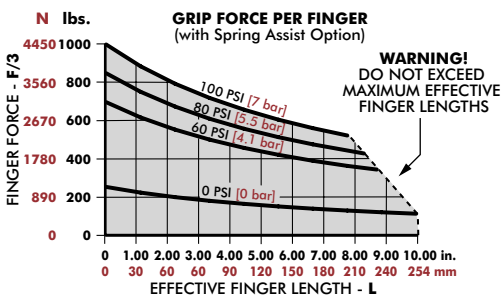

RTH-6M	Static	Dynamic
Maximum Tensile T	4320 N [971 lbs]	1315 N [296 lbs]
Maximum Compressive C	5810 N [1306 lbs]	1315 N [296 lbs]
Maximum Moment M_x	172 Nm [1522 in-lbs]	45 Nm [398 in-lbs]
Maximum Moment M_y	250 Nm [2213 in-lbs]	65 Nm [575 in-lbs]
Maximum Moment M_z	164 Nm [1452 in-lbs]	65 Nm [575 in-lbs]

*Capacities are per set of jaws and are not simultaneous

RTH-6M-L	Static	Dynamic
Maximum Tensile T	3860 N [868 lbs]	852 N [192 lbs]
Maximum Compressive C	5180 N [1165 lbs]	852 N [192 lbs]
Maximum Moment M_x	154 Nm [1363 in-lbs]	29 Nm [257 in-lbs]
Maximum Moment M_y	199 Nm [1761 in-lbs]	37 Nm [327 in-lbs]
Maximum Moment M_z	131 Nm [1159 in-lbs]	37 Nm [327 in-lbs]

*Capacities are per set of jaws and are not simultaneous

RTH-8M, -8M-L

3-Jaw Parallel Grippers | Dimensions and Technical Specifications

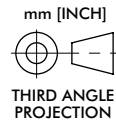
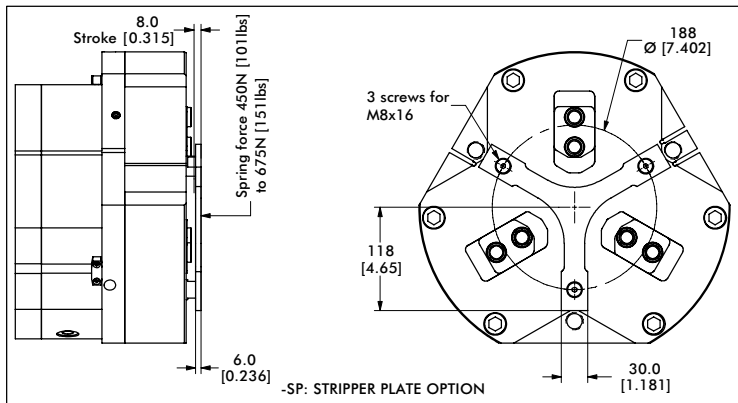
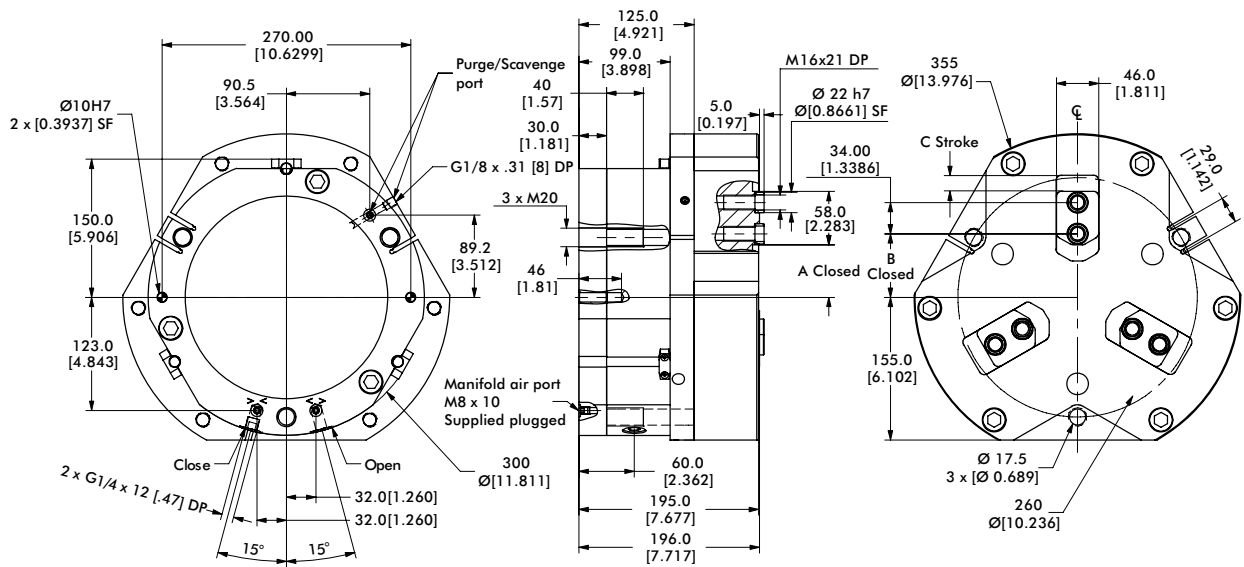

Model	A	B	C
RTH-8M	57.0 [2.244]	69.0 [2.717]	17.7 [0.70]
RTH-8M-L	39.5 [1.555]	51.5 [2.028]	35.1 [1.38]

Dimensions in mm [in]

Seal Repair Kits	RTH-8M
Buna-N Seal Repair Kit	SLKT-354
Buna-N Rear Inlet Seal Repair Kit	SLKT-366
Viton® Seal Repair Kit	SLKT-354V
Viton® Rear Inlet Seal Repair Kit	SLKT-366V

Loading Information

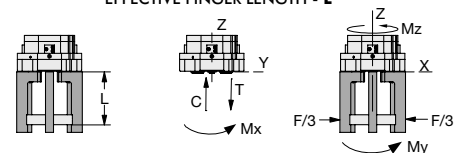
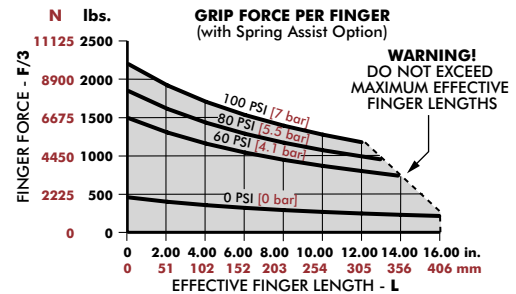
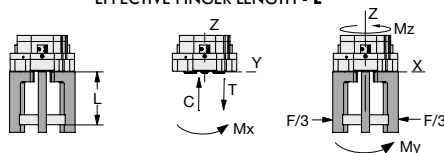
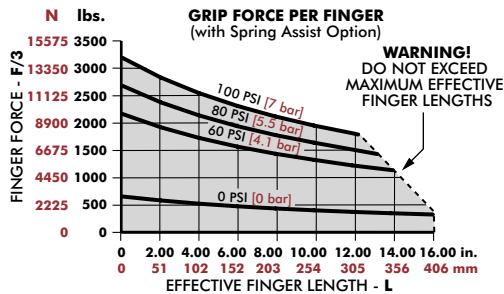

RTH-8M	Static	Dynamic
Maximum Tensile T	8230 N [1850 lbs]	2733 N [614 lbs]
Maximum Compressive C	10700 N [2405 lbs]	2733 N [614 lbs]
Maximum Moment M_x	455 Nm [4027 in-lbs]	131 Nm [1159 in-lbs]
Maximum Moment M_y	578 Nm [5116 in-lbs]	167 Nm [1478 in-lbs]
Maximum Moment M_z	362 Nm [3204 in-lbs]	167 Nm [1478 in-lbs]

†Capacities are per set of jaws and are not simultaneous

RTH-8M-L	Static	Dynamic
Maximum Tensile T	7080 N [1592 lbs]	1772 N [398 lbs]
Maximum Compressive C	9210 N [2070 lbs]	1772 N [398 lbs]
Maximum Moment M_x	391 Nm [3461 in-lbs]	85 Nm [752 in-lbs]
Maximum Moment M_y	428 Nm [3788 in-lbs]	93 Nm [823 in-lbs]
Maximum Moment M_z	268 Nm [2372 in-lbs]	93 Nm [823 in-lbs]

†Capacities are per set of jaws and are not simultaneous

PPC SERIES

3-Jaw Parallel Grippers | Features and Benefits | How To Order

Features:

- Multipurpose robust gripper with high repeatability
- Through-hole design for 3rd party tooling, imaging, part ejectors, hoses and sensing.
- Spring assist option maintains grip in case of air pressure loss
- Grip force range from 1474N to 4332N
- Repeatability of +/-0.02mm

Applications:

- Feed thru work piece applications
- Optical workpiece inspection via center hole
- Part feed/ejection, part cleaning, part presence



How To Order

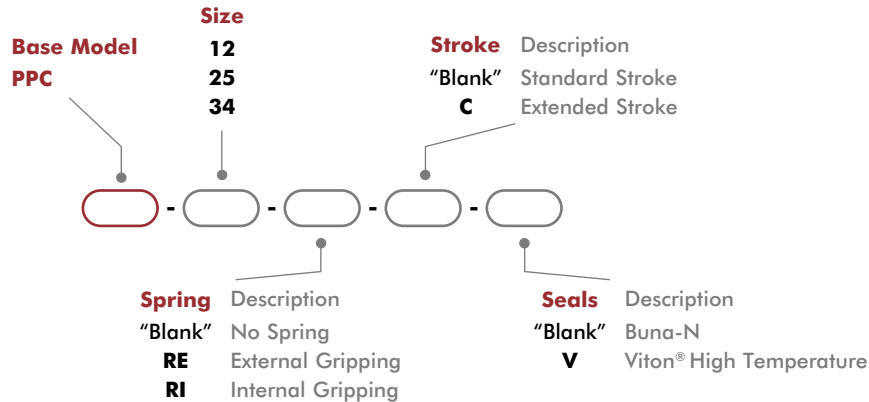

Accessories

Sensor Accessories	Model Numbers	Part Number	Qty/Unit
Inductive Sensor Mounting Kit (1 Holder, 1 Flag, 2 Spacers)	PPC-12	OSMK-105	1-2
Inductive Sensor Mounting Kit (1 Holder, 1 Flag, 2 Spacers)	PPC-25	OSMK-106	1-2
Inductive Sensor Mounting Kit (1 Holder, 1 Flag, 2 Spacers)	PPC-34	OSMK-107	1-2
NPN Inductive Sensor with Quick Disconnect*	All Models	OISN-011	1-4
PNP Inductive Sensor with Quick Disconnect*	All Models	OISP-011	1-4
Quick Disconnect Cable (2 meters long)*	All Models	CABL-010	1-4
Quick Disconnect Cable (5 meters long)*	All Models	CABL-013	1-4

*Sensor and cable sold separately.

3-Jaw Parallel Grippers | Technical Specifications

Specifications	Units	12	12-C	25	25-C
Total Rated Grip Force F @ 100 psi [7 bar]*	N [lbs]	1474 [331]	896 [201]	2620 [589]	1642 [369]
Total Stroke	mm [in]	10 [0.394]	16 [0.630]	13 [0.512]	20 [0.787]
Weight	kg [lbs]	1.0 [2.2]	1.1 [2.4]	2.2 [4.9]	2.3 [5.1]
Pressure Range (without spring)	bar [psi]	2-7 [30-100]			
Pressure Range (with spring)	bar [psi]	3-7 [45-100]			
Ingress Protection Class (IP)		IP54			
Displacement	cm ³ [in ³]	23 [1.40]		51 [3.11]	
Temperature Range (Buna-N seals)	°C [°F]	-35°~80° [-30°~180°]			
Temperature Range (Viton® seals)	°C [°F]	-30°~150° [-20°~300°]			
Actuation	sec.	0.03		0.04	
Repeatability	mm [in]	±0.02 [±0.0008]			

*With springs

Specifications	Units	34	34-C
Total Rated Grip Force F @ 100 psi [7 bar]*	N [lbs]	4332 [974]	2938 [638]
Total Stroke	mm [in]	20 [0.787]	30 [1.181]
Weight	kg [lbs]	5.1 [11.2]	5.3 [11.7]
Pressure Range (without spring)	bar [psi]	2-7 [30-100]	
Pressure Range (with spring)	bar [psi]	3-7 [45-100]	
Ingress Protection Class (IP)		IP54	
Displacement	cm ³ [in ³]	128 [7.81]	
Temperature Range (Buna-N seals)	°C [°F]	-35°~80° [-30°~180°]	
Temperature Range (Viton® seals)	°C [°F]	-30°~150° [-20°~300°]	
Actuation	sec.	0.06	
Repeatability	mm [in]	±0.02 [±0.0008]	

*With springs

PPC-12, -12-C

3-Jaw Parallel Grippers | Dimensions and Technical Specifications

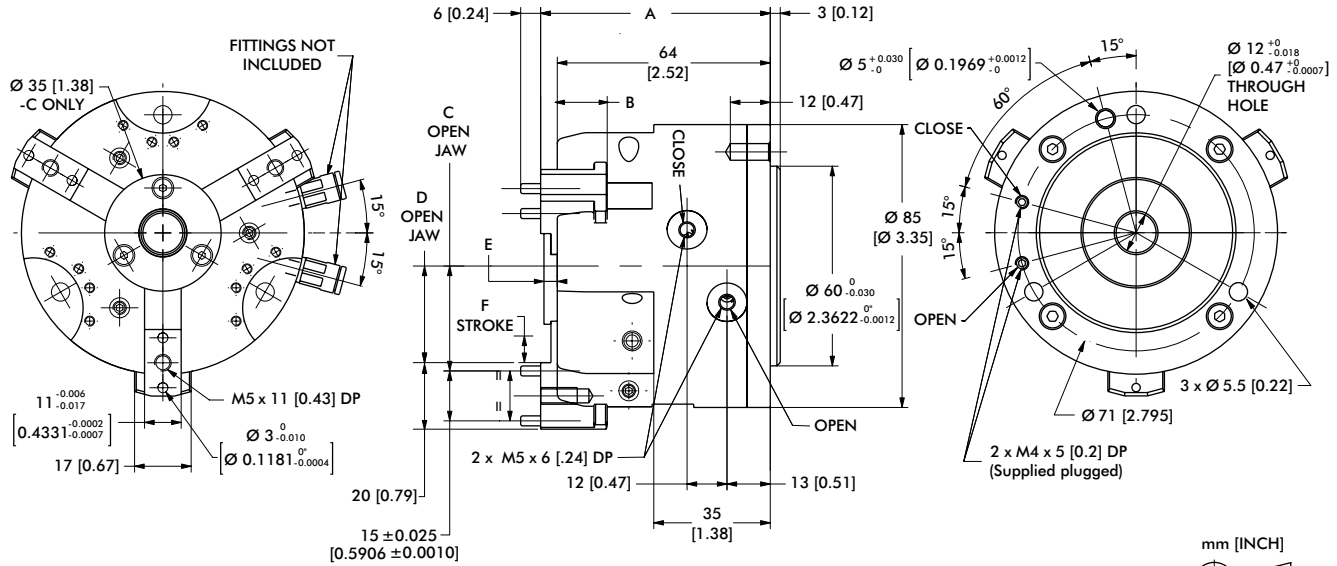
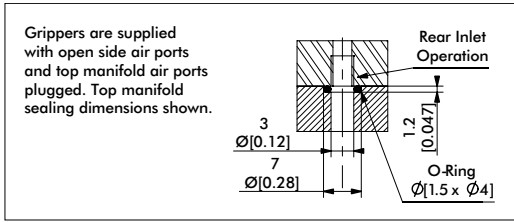

Model	A	B	C	D	E	F
PPC-12	65 [2.56]	64 [2.52]	25.5 [1.004]	23 [0.906]	--	5 [0.2]
PPC-12-C	69 [2.72]	64 [2.52]	31.5 [1.241]	29.03 [1.143]	4 [0.16]	8 [0.31]

Dimensions in mm [in]

Loading Information

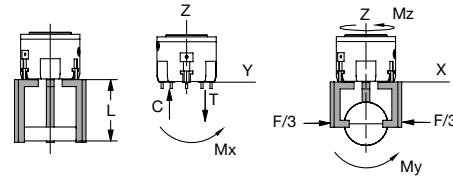
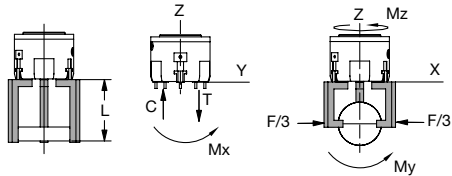
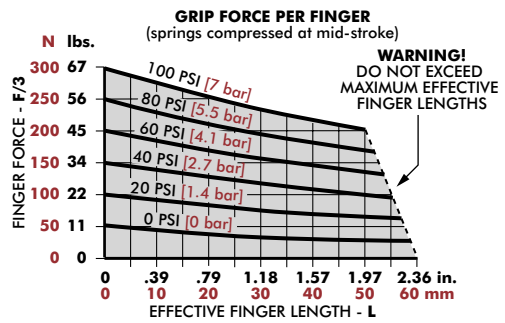
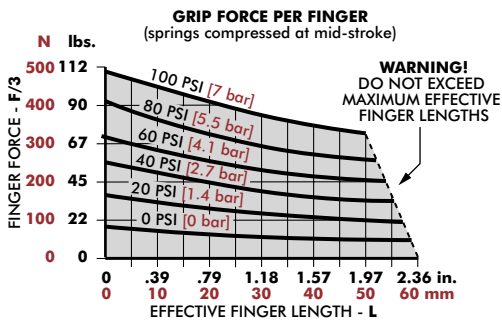

PPC-12	Static	Dynamic
Maximum Tensile T	850 N [191 lbs]	220 N [49 lbs]
Maximum Compressive C	1150 N [259 lbs]	220 N [49 lbs]
Maximum Moment M_x	20 Nm [177 in-lbs]	6 Nm [53 in-lbs]
Maximum Moment M_y	20 Nm [177 in-lbs]	6 Nm [53 in-lbs]
Maximum Moment M_z	50 Nm [443 in-lbs]	10 Nm [89 in-lbs]

*Capacities are per set of jaws and are not simultaneous

PPC-12-C	Static	Dynamic
Maximum Tensile T	[214 lbs] 950 N	220 N [49 lbs]
Maximum Compressive C	[281 in-lbs] 1250 N	220 N [49 lbs]
Maximum Moment M_x	[177 in-lbs] 20 Nm	6 Nm [53 in-lbs]
Maximum Moment M_y	[177 in-lbs] 20 Nm	6 Nm [53 in-lbs]
Maximum Moment M_z	[531 in-lbs] 60 Nm	10 Nm [89 in-lbs]

*Capacities are per set of jaws and are not simultaneous

PPC-34, -34-C

3-Jaw Parallel Grippers | Dimensions and Technical Specifications

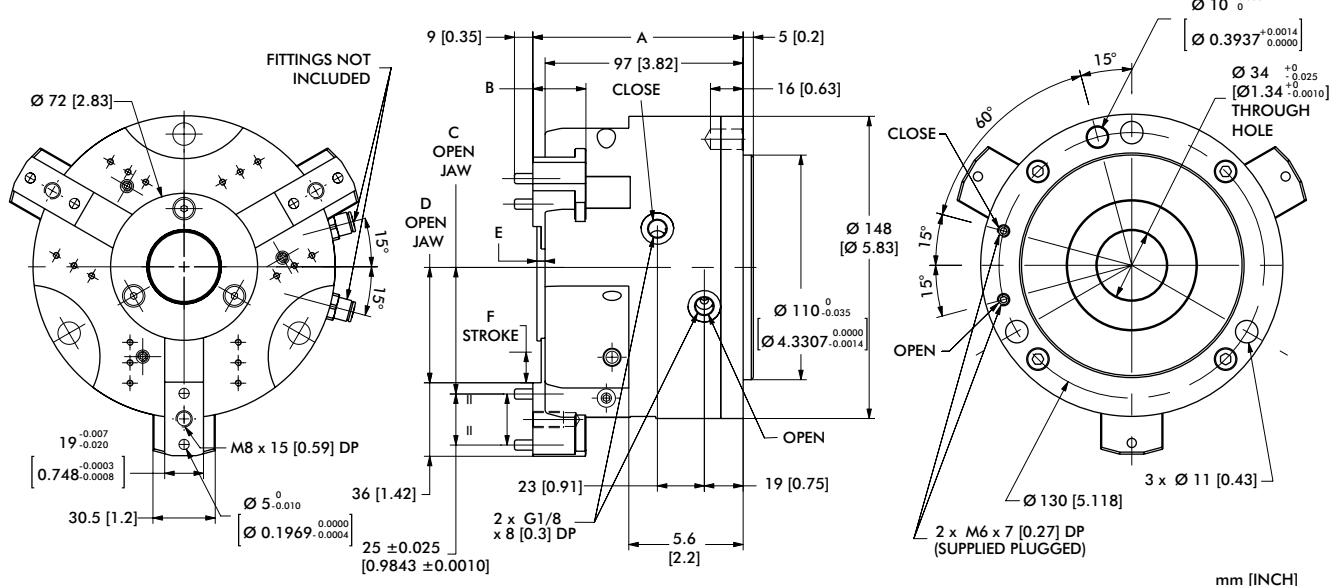
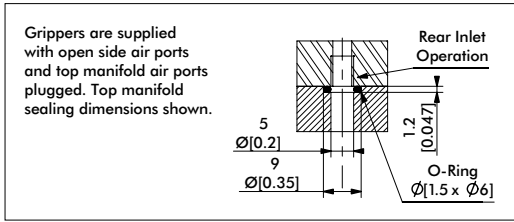

Model	A	B	C	D	E	F
PPC-34	98 [3.86]	97 [3.82]	52 [2.047]	46.5 [1.831]	--	10 [0.39]
PPC-34-C	103 [4.06]	97 [3.82]	62 [2.441]	56.5 [2.224]	4 [0.16]	15 [0.59]

Dimensions in mm [in]

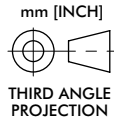

Loading Information

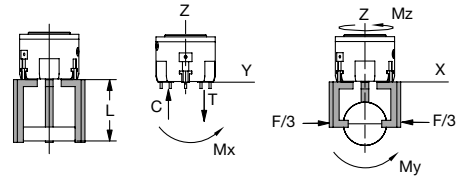
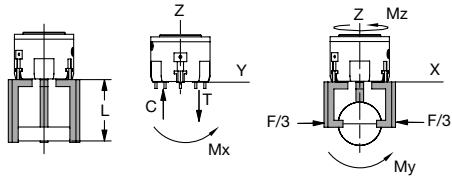
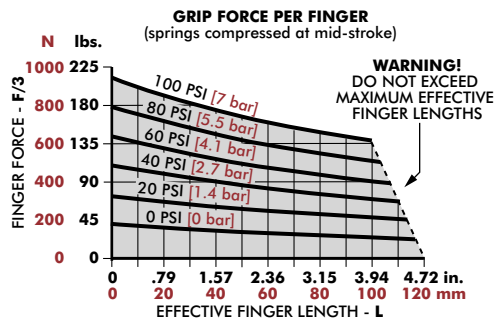
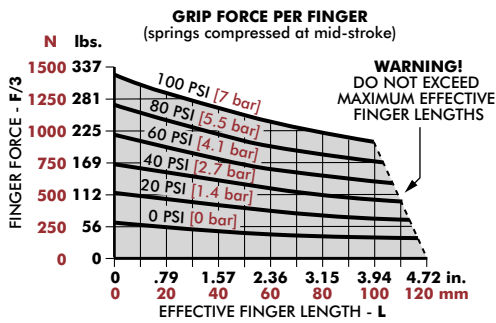

PPC-34	Static	Dynamic
Maximum Tensile T	1950 N [438 lbs]	650 N [146 lbs]
Maximum Compressive C	2150 N [483 lbs]	650 N [146 lbs]
Maximum Moment M_x	65 Nm [575 in-lbs]	32 Nm [283 in-lbs]
Maximum Moment M_y	65 Nm [575 in-lbs]	32 Nm [283 in-lbs]
Maximum Moment M_z	100 Nm [885 in-lbs]	55 Nm [487 in-lbs]

*Capacities are per set of jaws and are not simultaneous

PPC-34-C	Static	Dynamic
Maximum Tensile T	2150 N [438 lbs]	650 N [146 lbs]
Maximum Compressive C	2350 N [528 lbs]	650 N [146 lbs]
Maximum Moment M_x	65 Nm [575 in-lbs]	32 Nm [283 in-lbs]
Maximum Moment M_y	65 Nm [575 in-lbs]	32 Nm [283 in-lbs]
Maximum Moment M_z	120 Nm [1062 in-lbs]	55 Nm [487 in-lbs]

*Capacities are per set of jaws and are not simultaneous

REP3 SERIES

3-Jaw Parallel Grippers | Features and Benefits | How To Order

Features:

- Multipurpose robust gripper with high repeatability
- Spring assist option maintains grip in case of air pressure loss
- Uses inductive or magneto resistive sensors for sensing jaw position
- Grip force range from 771N to 2235N
- Purge and scavenge ports for harsh & clean environments
- Repeatability of +/-0.02mm

Applications:

- Long cycle life requirements
- High vibration environments
- Pick and place, part feeds



How To Order

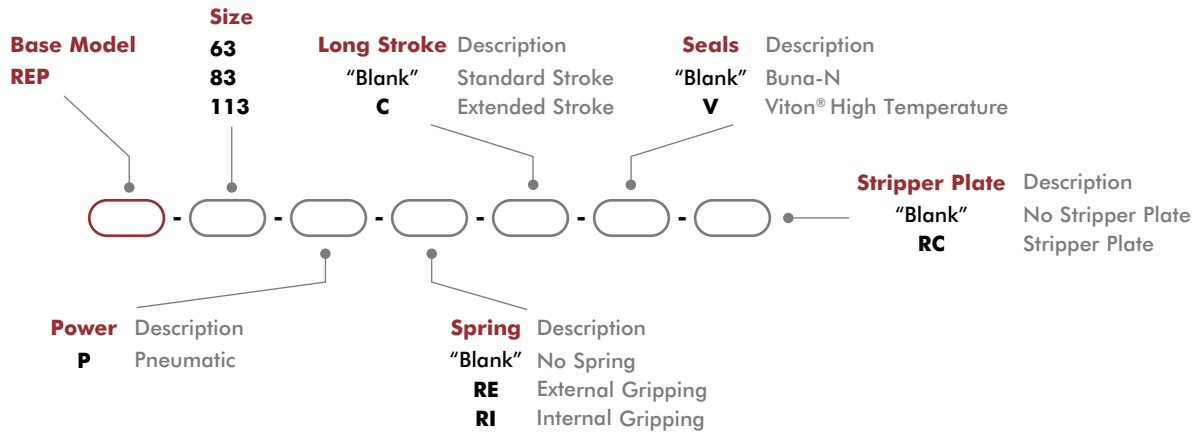

Accessories

Sensor Accessories	Model Numbers	Part Number	Qty/Unit
NPN Inductive Sensor with M8 Quick Disconnect*	All Models	OISN-011	1-4
PNP Inductive Sensor with M8 Quick Disconnect*	All Models	OISP-011	1-4
NPN Magneto Resistive Sensor with Quick Disconnect*	All Models	OHSN-006	1-2
PNP Magneto Resistive Sensor with Quick Disconnect*	All Models	OHSP-006	1-2
NPN Magneto Resistive Sensor (Short Barrel) with Qk Disconnect*	All Models	OHSN-017	1-2
PNP Magneto Resistive Sensor (Short Barrel) with Qk Disconnect*	All Models	OHSP-017	1-2
M8 Quick Disconnect 2 Meter Cable Length*	All Models	CABL-010	1-4
M8 Quick Disconnect 2 Meter Cable Length*	All Models	CABL-013	1-4
Inductive Sensor Mounting Kit (1 holder, 1 flag, 2 spacers)	63	OSMK-105	1-2
Inductive Sensor Mounting Kit (1 holder, 1 flag, 2 spacers)	83	OSMK-106	1-2
Inductive Sensor Mounting Kit (1 holder, 1 flag, 2 spacers)	113	OSMK-107	1-2

* Sensor and cable sold separately. †The gripper comes with adjustable slots for two magnetic sensors (to control jaw position). Must be used with the -RE or -RI option.

3-Jaw Parallel Grippers | Technical Specifications

Specifications	Units	63	63-C	83	83-C	113	113-C
Total Rated Grip Force F @ 100 psi [7 bar]*	N [lbs]	753 [169]	469 [105]	2077 [467]	1341 [301]	3268 [735]	2180 [490]
Total Stroke	mm [in]	10 [0.394]	16 [0.630]	13 [0.512]	20 [0.787]	20 [0.787]	30 [1.181]
Weight	kg [lbs]	0.55 [1.2]		0.9 [2.0]		2.45 [5.4]	
Pressure Range w/o Spring	bar [psi]	2-7 [30-100]					
Pressure Range with Spring	bar [psi]	3-7 [45-100]					
Ingress Protection Class (IP)		IP55					
Displacement	cm ³ [in ³]	12 [0.72]		35 [2.13]		87 [5.31]	
Temperature Range (Buna-N seals)	°C [°F]	-35°~80° [-30°~180°]					
Temperature Range (Viton® seals)	°C [°F]	-30°~150° [-20°~300°]					
Actuation (open/close)	sec.	0.10		0.18		0.35	
Accuracy	mm [in]	±0.05 [±0.002]					
Repeatability	mm [in]	±0.02 [±0.0008]					
Valve to Actuate Single Acting		3-way, 2-position					
Valve to Actuate Double Acting		4-way, 2-position					

* with springs

REP-63, -63-C

3-Jaw Parallel Grippers | Dimensions and Technical Specifications

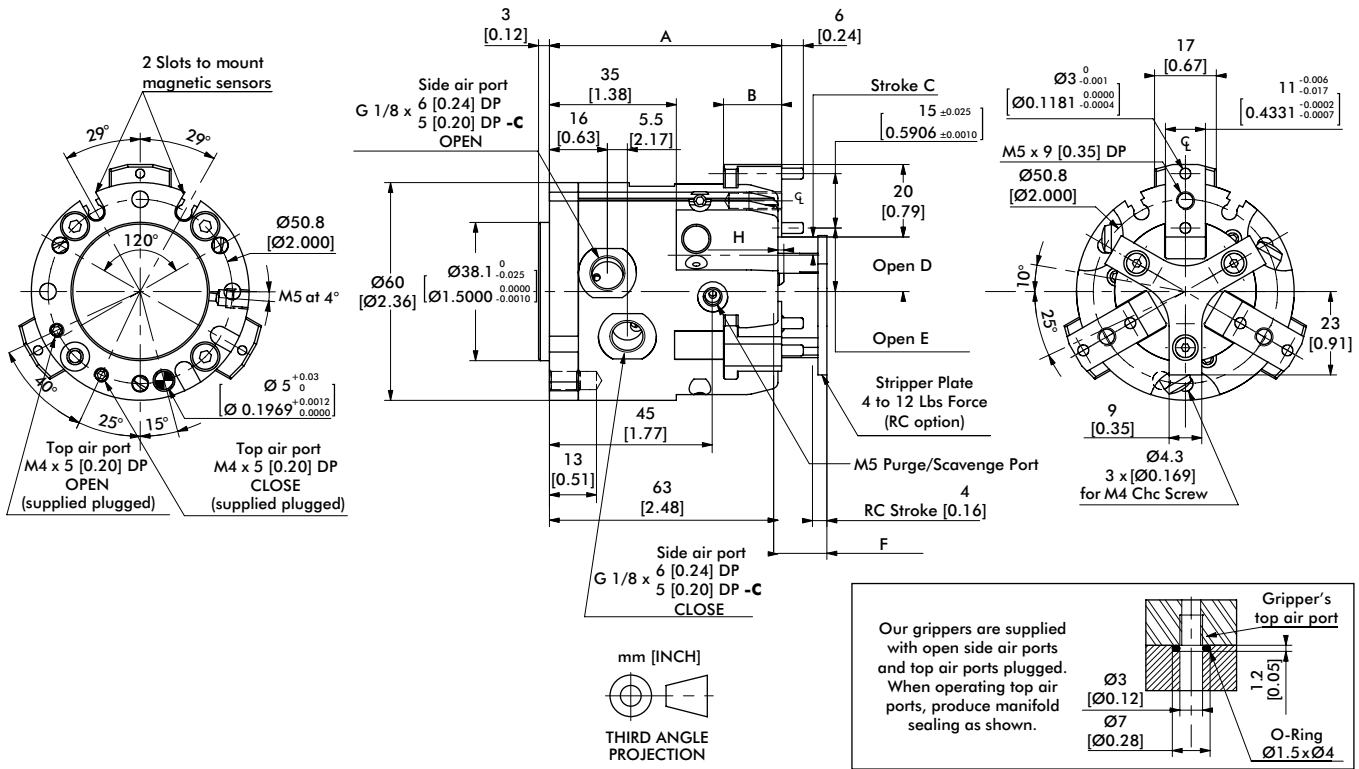

Model	A	B	C	D	E	F	H
REP-63	62 [2.52]	16 [0.63]	5 [0.20]	15 [0.59]	17.5 [0.689]	13.5 [0.531]	1.6 [0.06]
REP-63-C	68 [2.68]	20 [0.79]	8 [0.31]	21 [0.83]	23.5 [0.926]	17.5 [0.689]	5.6 [0.22]

Dimensions in mm [in]

Seal Repair Kits	REP-63
Buna-N Seal Repair Kit	SLKT-155
Viton® Seal Repair Kit	SLKT-155V

Loading Information

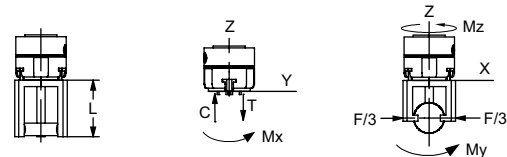
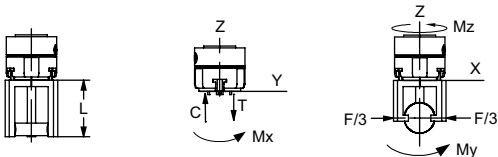
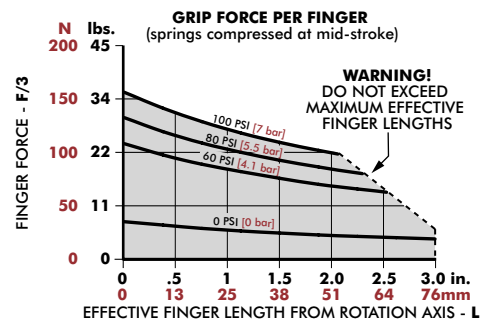
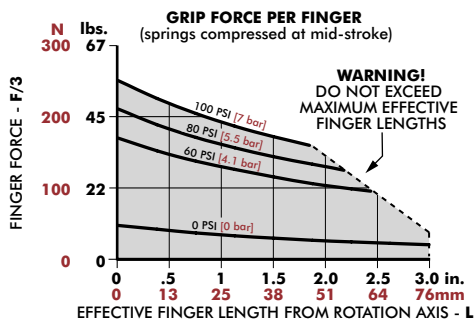

REP-63	Static
Maximum Tensile T	860 N [193 lbs]
Maximum Compressive C	1150 N [259 lbs]
Maximum Moment M_x	18 Nm [159 in-lbs]
Maximum Moment M_y	30 Nm [266 in-lbs]
Maximum Moment M_z	30 Nm [44 in-lbs]

†Capacities are per set of jaws and are not simultaneous

REP-63-C	Static
Maximum Tensile T	860 N [193 lbs]
Maximum Compressive C	1150 N [259 lbs]
Maximum Moment M_x	15 Nm [133 in-lbs]
Maximum Moment M_y	30 Nm [266 in-lbs]
Maximum Moment M_z	50 Nm [443 in-lbs]

†Capacities are per set of jaws and are not simultaneous

3-Jaw Parallel Grippers | Dimensions and Technical Specifications

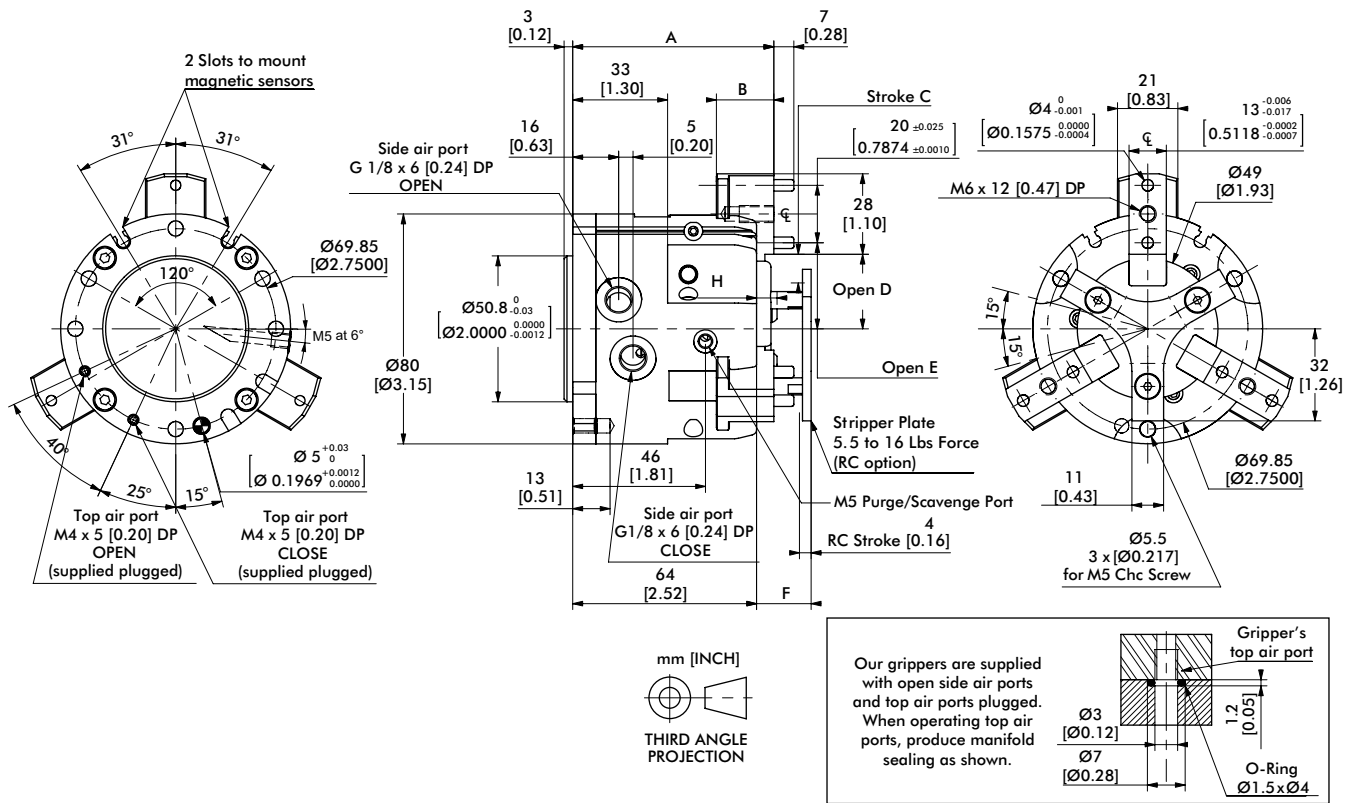

Model	A	B	C	D	E	F	H
REP-83	65 [2.56]	15 [0.59]	6.5 [0.256]	19 [0.75]	23 [0.91]	14 [0.55]	2.1 [0.08]
REP-83-C	70 [2.76]	20 [0.79]	10 [0.39]	26 [1.10]	30 [1.18]	19 [0.75]	7.1 [0.28]

Dimensions in mm [in]

Seal Repair Kits	REP-83
Buna-N Seal Repair Kit	SLKT-157
Viton® Seal Repair Kit	SLKT-157V

Loading Information

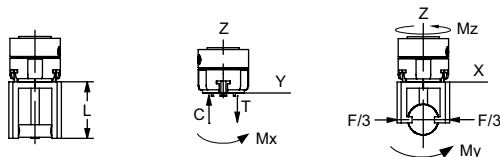
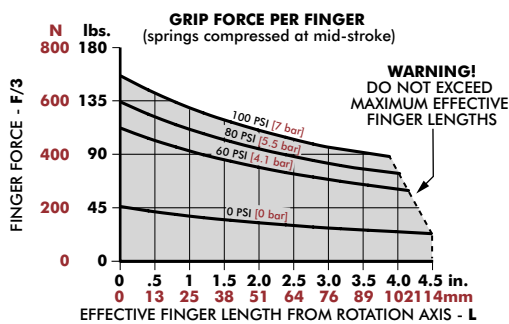

REP-83	Static
Maximum Tensile T	1250 N [281 lbs]
Maximum Compressive C	1400 N [315 lbs]
Maximum Moment M_x	30 Nm [266 in-lbs]
Maximum Moment M_y	55 Nm [487 in-lbs]
Maximum Moment M_z	60 Nm [531 in-lbs]

[†]Capacities are per set of jaws and are not simultaneous

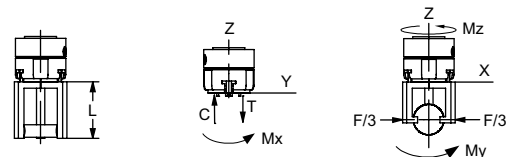
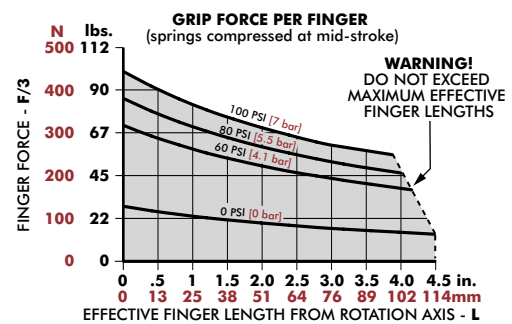

REP-83-C	Static
Maximum Tensile T	1210 N [272 lbs]
Maximum Compressive C	1360 N [306 lbs]
Maximum Moment M_x	25 Nm [221 in-lbs]
Maximum Moment M_y	50 Nm [443 in-lbs]
Maximum Moment M_z	60 Nm [531 in-lbs]

[†]Capacities are per set of jaws and are not simultaneous

REP-113, -113-C

3-Jaw Parallel Grippers | Dimensions and Technical Specifications

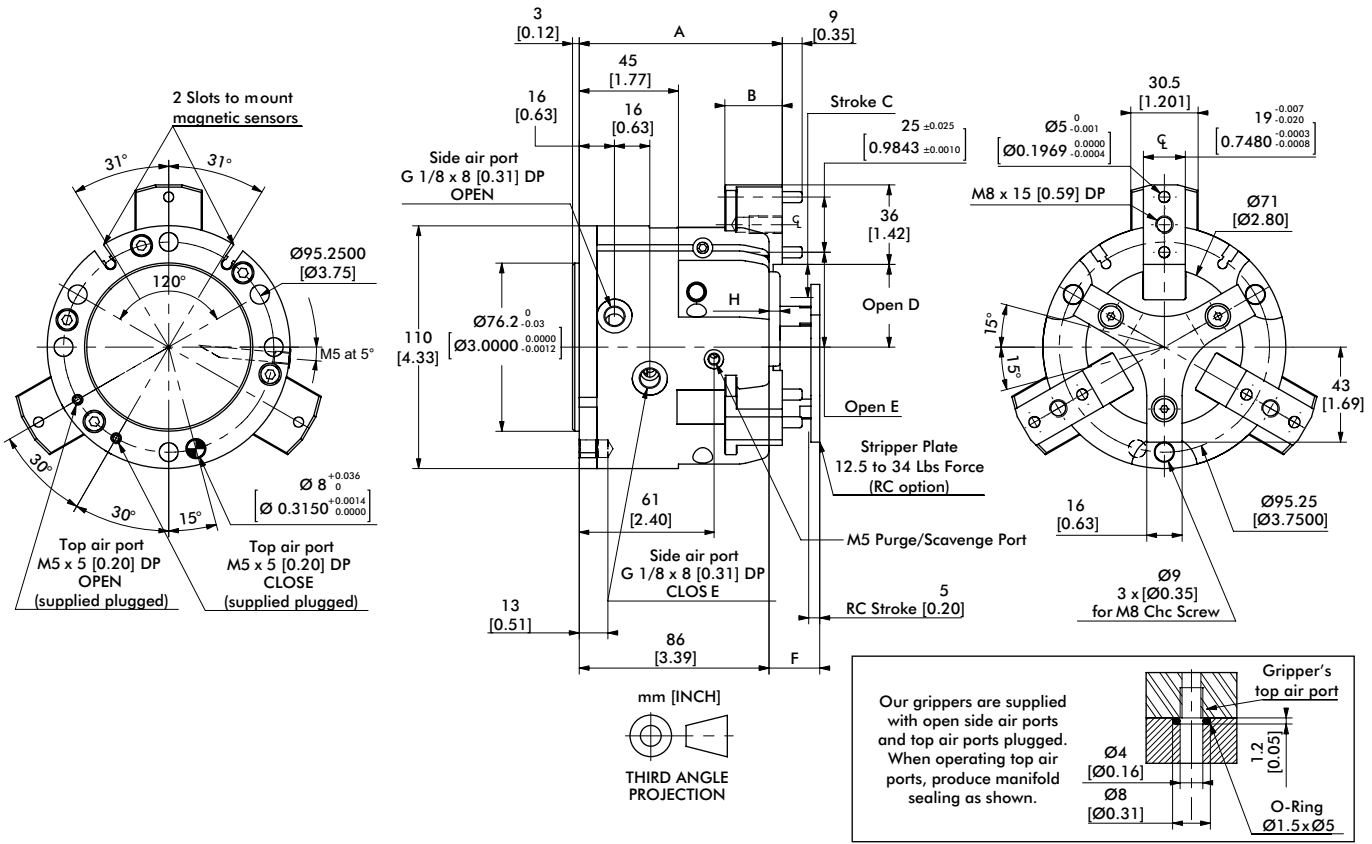

Model	A	B	C	D	E	F	H
REP-113	87 [3.43]	21 [0.83]	10 [0.39]	27.5 [1.083]	33 [1.30]	18 [0.71]	--
REP-113-C	92 [3.62]	26 [1.02]	15 [0.59]	37.5 [1.476]	43 [1.69]	23 [0.91]	5 [0.20]

Dimensions in mm [in]

Seal Repair Kits	REP-113
Buna-N Seal Repair Kit	SLKT-158
Viton® Seal Repair Kit	SLKT-158V

Loading Information

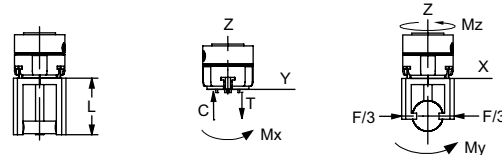
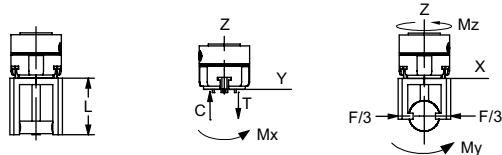
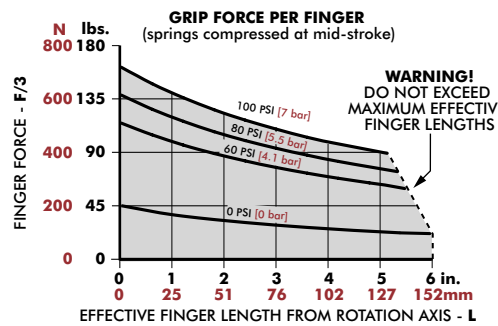
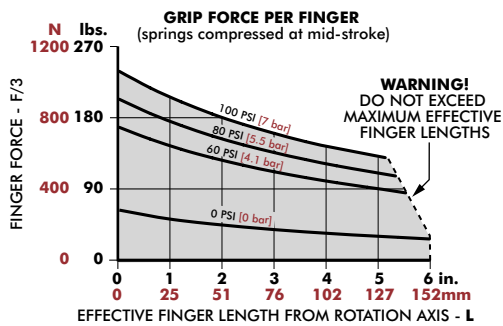

REP-113	Static
Maximum Tensile T	1980 N [445 lbs]
Maximum Compressive C	2150 N [483 lbs]
Maximum Moment M_x	58 Nm [513 in-lbs]
Maximum Moment M_y	100 Nm [885 in-lbs]
Maximum Moment M_z	110 Nm [974 in-lbs]

†Capacities are per set of jaws and are not simultaneous

REP-113-C	Static
Maximum Tensile T	1970 N [443 lbs]
Maximum Compressive C	2140 N [481 lbs]
Maximum Moment M_x	52 Nm [460 in-lbs]
Maximum Moment M_y	100 Nm [885 in-lbs]
Maximum Moment M_z	110 Nm [974 in-lbs]

†Capacities are per set of jaws and are not simultaneous

RPC SERIES

3-Jaw Parallel Grippers | Features and Benefits | How To Order

Features:

- Self-centering gripper with very high grip force
- Optional stripper plate for part insertion/ejection
- Ideal for gripping small to very large round parts
- Grip force range from 445N to 13345N
- Repeatability of +/-0.03mm

Applications:

- Part feed/ejection
- Lathe applications
- Large heavy round parts



How To Order

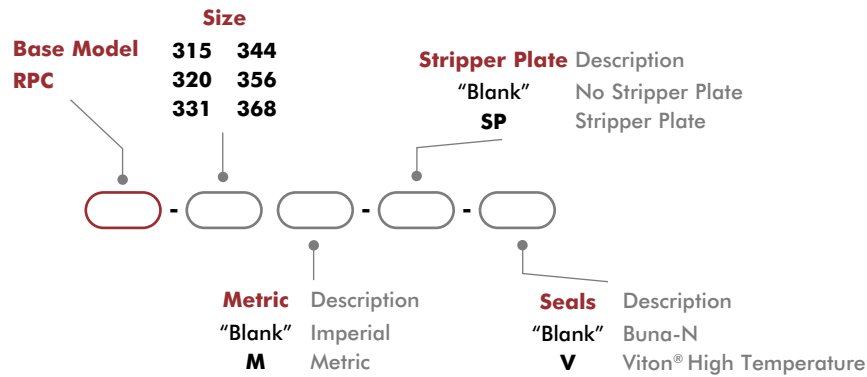

Accessories

Sensor Accessories	Model Numbers	Part Number	Qty/Unit
4mm NPN Magneto Resistive Sensor with Quick Disconnect*	All Models	OHSN-017	1-2
4mm PNP Magneto Resistive Sensor with Quick Disconnect*	All Models	OHSP-017	1-2
4mm NPN 90° Magneto Resistive Sensor with Quick Disconnect*	All Models	OHSN-011	1-2
4mm PNP 90° Magneto Resistive Sensor with Quick Disconnect*	All Models	OHSP-011	1-2
Quick Disconnect Cable (2 meters long)*	All Models	CABL-010	1-2
Quick Disconnect Cable (5 meters long)*	All Models	CABL-013	1-2
Fail Safe Valve (Imperial)	315, 320, 331	OFSV-001	1
Fail Safe Valve (Metric)	315, 320, 331	OFSV-004	1
Fail Safe Valve (Imperial)	344, 356, 368	OFSV-002	1
Fail Safe Valve (Metric)	344, 356, 368	OFSV-005	1

* Sensor and cable sold separately.

3-Jaw Parallel Grippers | Technical Specifications

Specifications	Units	315	320	331
Total Rated Grip Force F @ 100 psi [7 bar]*	N [lbs]	445 [100]	1334 [300]	3336 [750]
Total Stroke	mm [in]	7.6 [0.30]	10.2 [0.40]	15.7 [0.62]
Weight	kg [lbs]	0.24 [0.53]	0.45 [1.0]	1.4 [3.0]
Pressure Range	bar [psi]	1.4-7 [20-100]		
Ingress Protection Class (IP)		IP54		
Displacement	cm ³ [in ³]	5.2 [0.32]	17.7 [1.08]	52.3 [3.31]
Temperature Range (Buna-N seals)	°C [°F]	-35°~80° [-30°~180°]		
Temperature Range (Viton® seals)	°C [°F]	-30°~150° [-20°~300°]		
Actuation	sec.	0.12	0.18	0.23
Accuracy	mm [in]	±0.05 [±0.002]		
Repeatability	mm [in]	±0.03 [±0.001]		
Valve to Actuate Double Acting		4-way, 2-position		

*With springs

Specifications	Units	344	356	368
Total Rated Grip Force F @ 100 psi [7 bar]*	N [lbs]	4003 [900]	6339 [1425]	13345 [3000]
Total Stroke	mm [in]	22.2 [0.88]	28.4 [1.12]	34.9 [1.38]
Weight	kg [lbs]	2.7 [6.0]	4.4 [9.75]	7.3 [16]
Pressure Range	bar [psi]	1.4-7 [20-100]		
Ingress Protection Class (IP)		IP54		
Displacement	cm ³ [in ³]	120 [7.37]	253 [13.46]	424 [25.86]
Temperature Range (Buna-N seals)	°C [°F]	-35°~80° [-30°~180°]		
Temperature Range (Viton® seals)	°C [°F]	-30°~150° [-20°~300°]		
Actuation	sec.	0.47	0.50	0.74
Accuracy	mm [in]	±0.05 [±0.002]		
Repeatability	mm [in]	±0.03 [±0.001]		
Valve to Actuate Double Acting		4-way, 2-position		

*With springs

RPC-315

3-Jaw Parallel Grippers | Dimensions and Technical Specifications

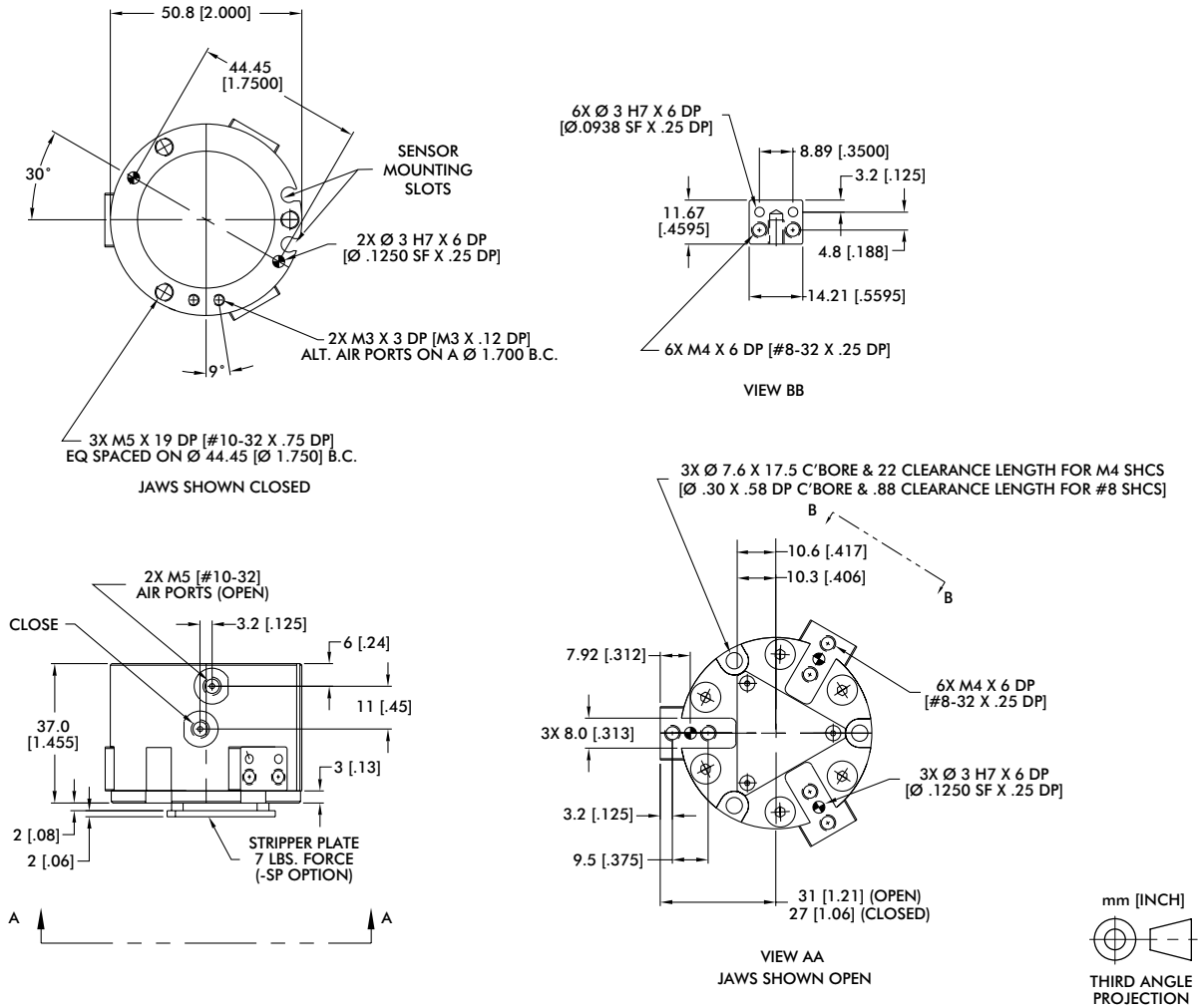

Loading Information

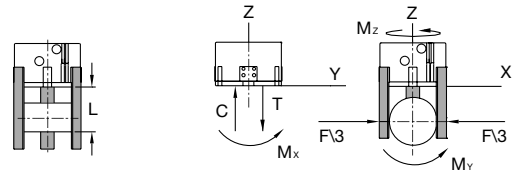
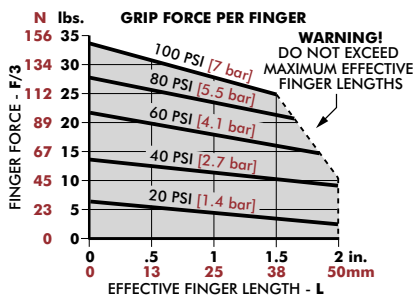

RPC-315	Static	Dynamic
Maximum Tensile T	1334 N [300 lbs]	445 N [100 lbs]
Maximum Compressive C	1334 N [300 lbs]	445 N [100 lbs]
Maximum Moment M_x	28 Nm [250 in-lbs]	8 Nm [75 in-lbs]
Maximum Moment M_y	28 Nm [250 in-lbs]	8 Nm [75 in-lbs]
Maximum Moment M_z	17 Nm [150 in-lbs]	6 Nm [50 in-lbs]

*Capacities are per set of jaws and are not simultaneous

3-Jaw Parallel Grippers | Dimensions and Technical Specifications

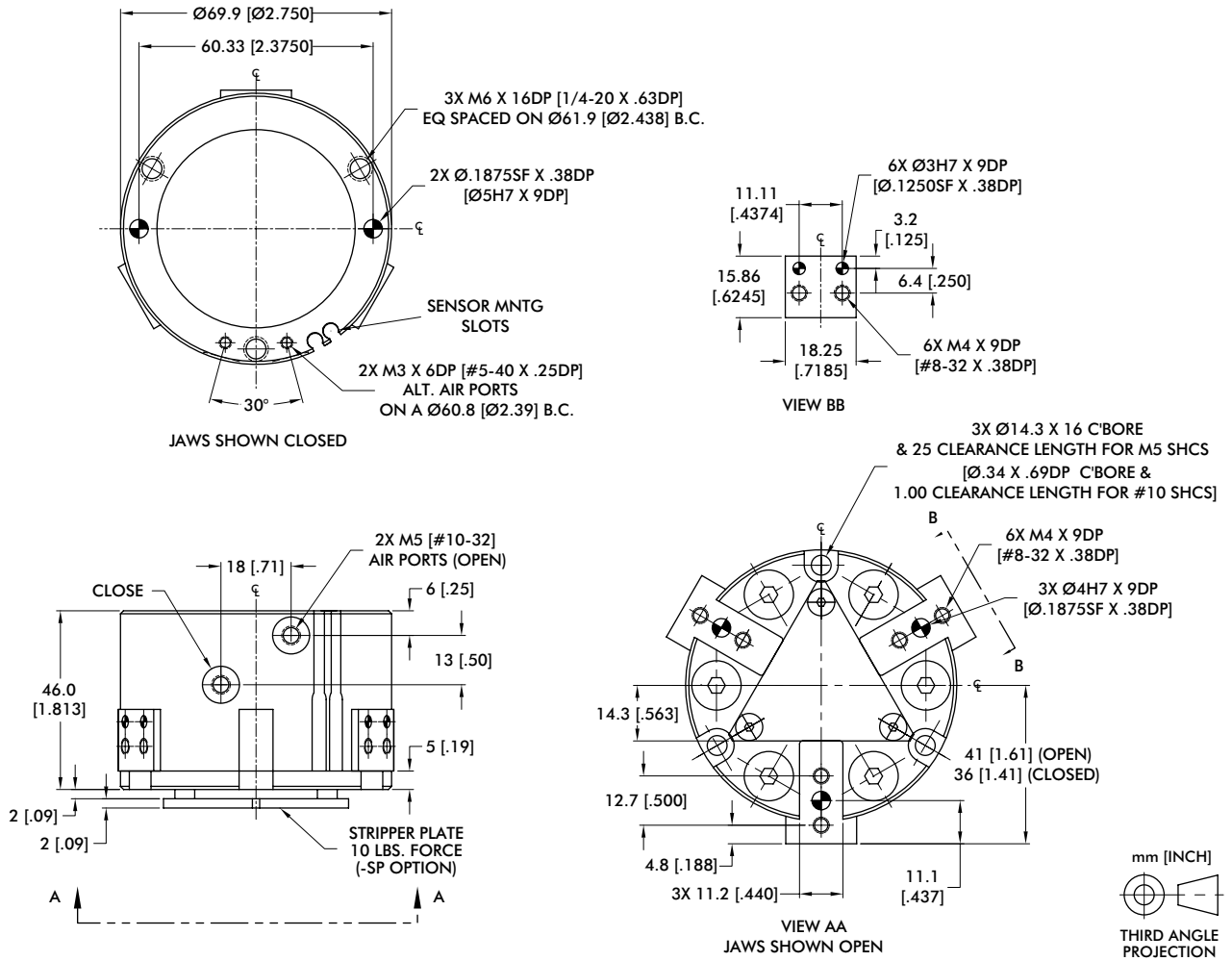

Loading Information

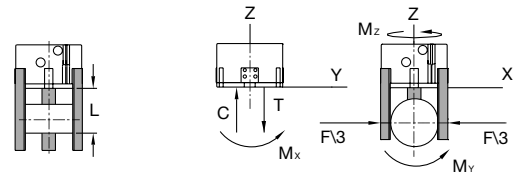
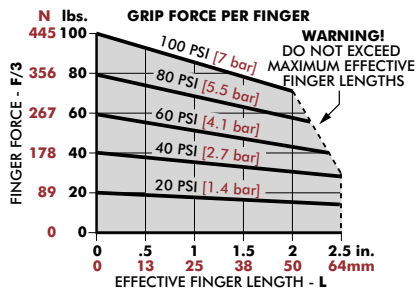

RPC-320	Static	Dynamic
Maximum Tensile T	3336 N [750 lbs]	1112 N [250 lbs]
Maximum Compressive C	3336 N [750 lbs]	1112 N [250 lbs]
Maximum Moment M_x	85 Nm [750 in-lbs]	28 Nm [255 in-lbs]
Maximum Moment M_y	85 Nm [750 in-lbs]	28 Nm [255 in-lbs]
Maximum Moment M_z	40 Nm [350 in-lbs]	11 Nm [100 in-lbs]

*Capacities are per set of jaws and are not simultaneous

RPC-331

3-Jaw Parallel Grippers | Dimensions and Technical Specifications

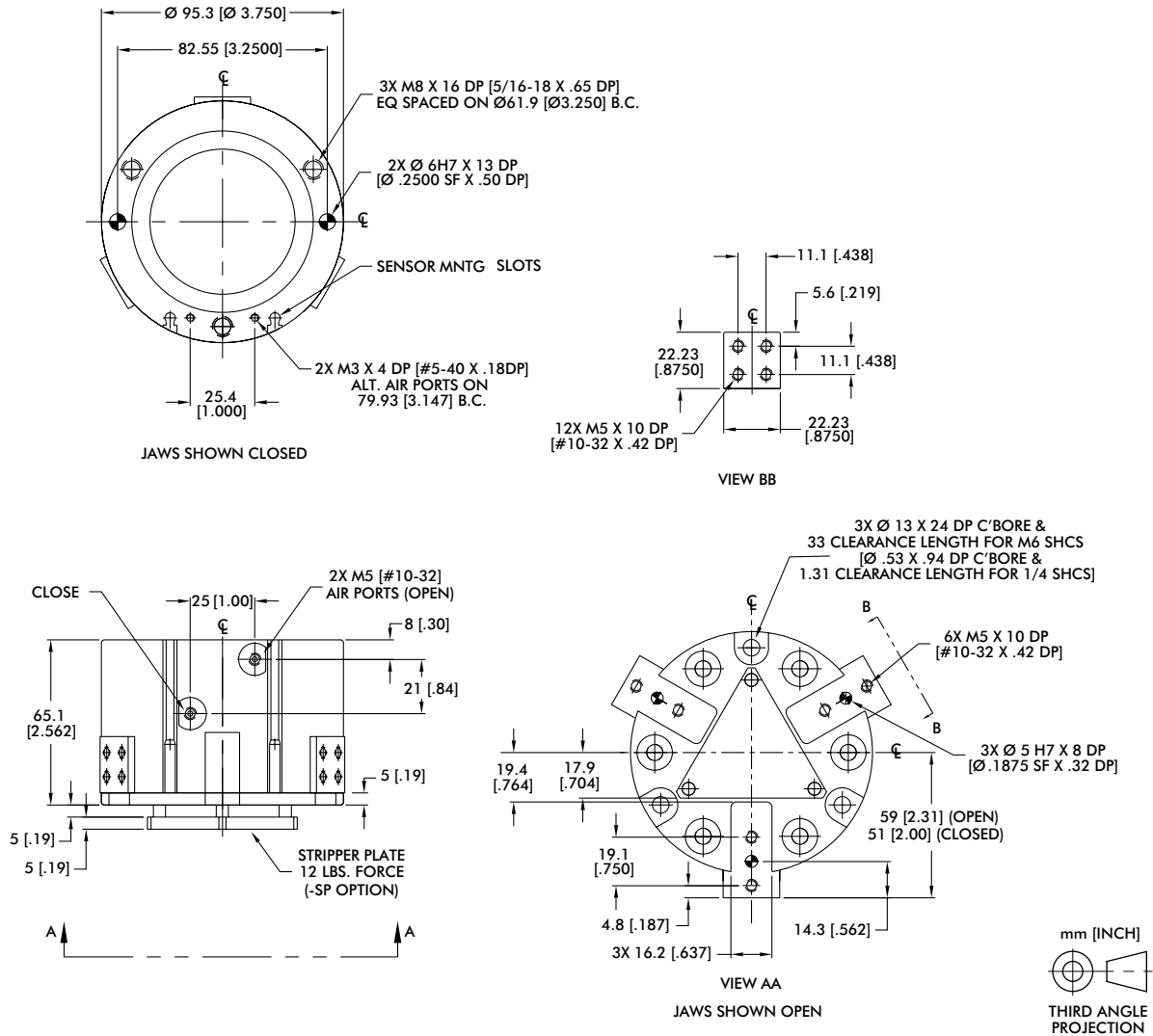

Loading Information

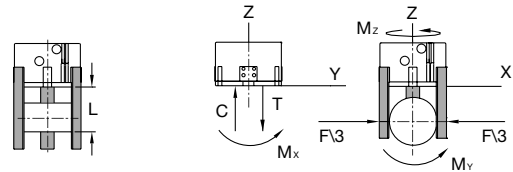
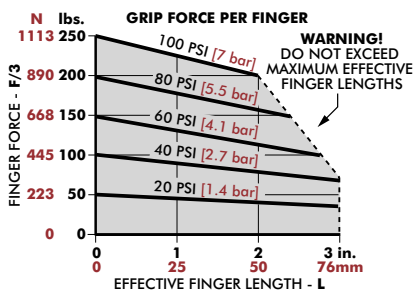

RPC-331	Static	Dynamic
Maximum Tensile T	5560 N [1250 lbs]	1779 N [400 lbs]
Maximum Compressive C	5560 N [1250 lbs]	1779 N [400 lbs]
Maximum Moment M_x	141 Nm [1250 in-lbs]	45 Nm [400 in-lbs]
Maximum Moment M_y	141 Nm [1250 in-lbs]	45 Nm [400 in-lbs]
Maximum Moment M_z	113 Nm [1000 in-lbs]	34 Nm [300 in-lbs]

*Capacities are per set of jaws and are not simultaneous

3-Jaw Parallel Grippers | Dimensions and Technical Specifications

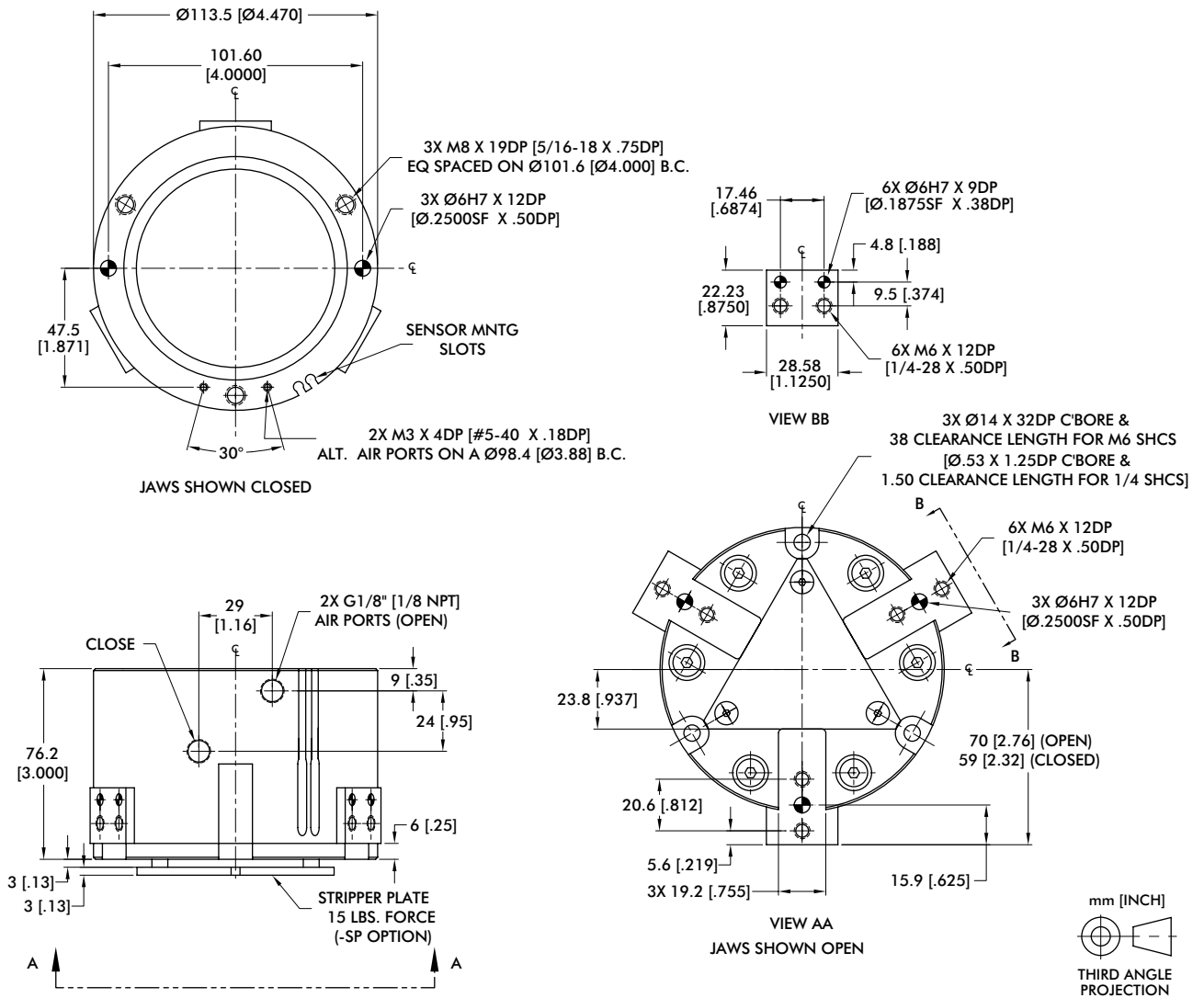

Loading Information

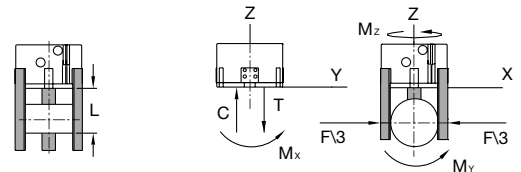
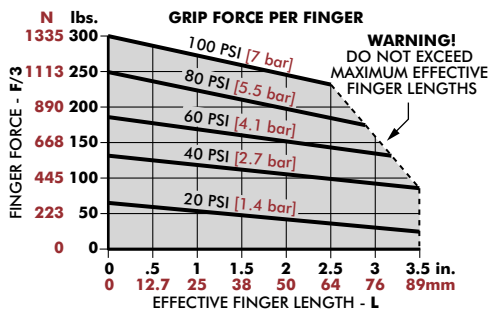

RPC-344	Static	Dynamic
Maximum Tensile T	8896 N [2000 lbs]	3336 N [750 lbs]
Maximum Compressive C	8896 N [2000 lbs]	3336 N [750 lbs]
Maximum Moment M_x	226 Nm [2000 in-lbs]	85 Nm [750 in-lbs]
Maximum Moment M_y	226 Nm [2000 in-lbs]	85 Nm [750 in-lbs]
Maximum Moment M_z	170 Nm [1500 in-lbs]	57 Nm [500 in-lbs]

*Capacities are per set of jaws and are not simultaneous

RPC-356

3-Jaw Parallel Grippers | Dimensions and Technical Specifications

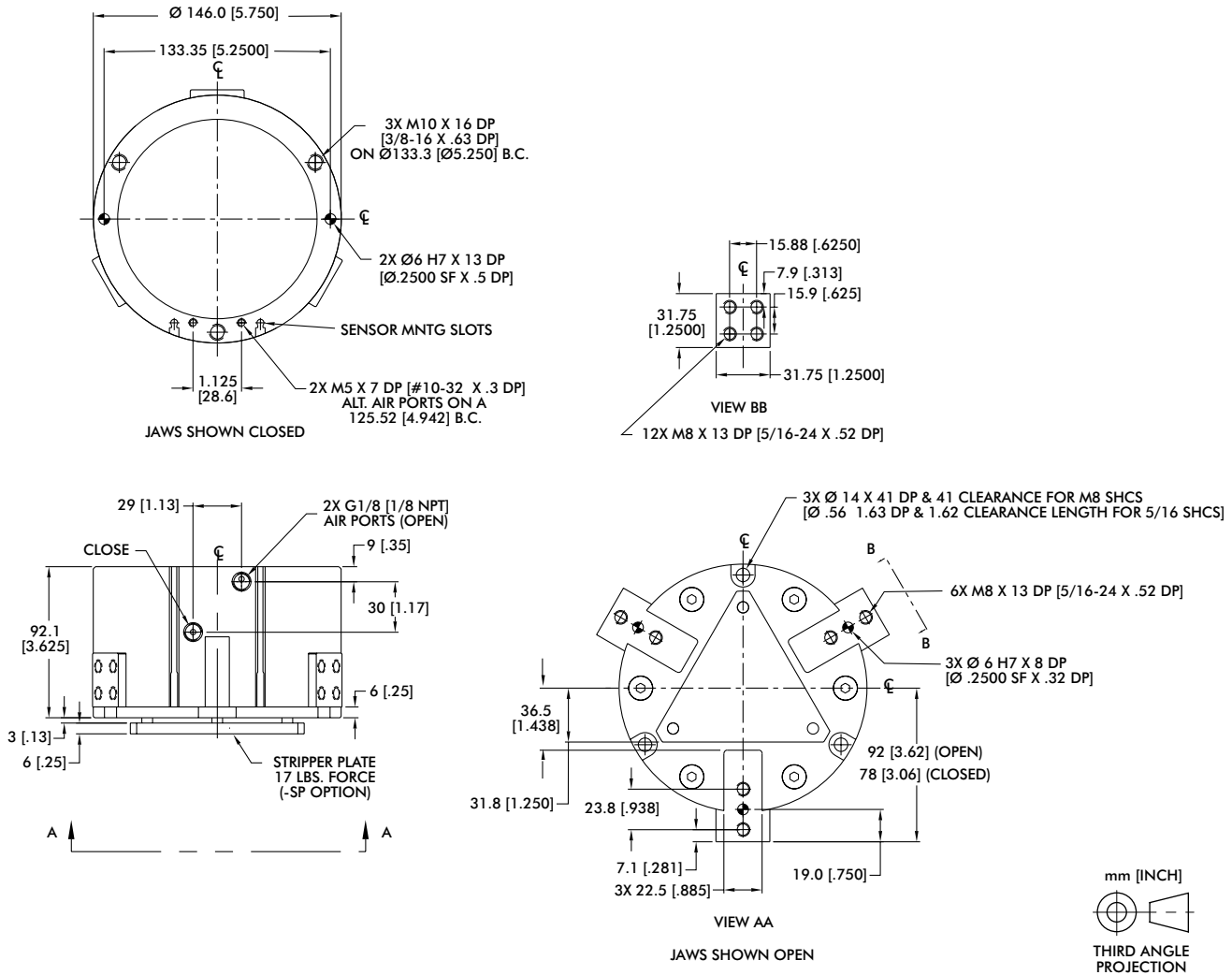

Loading Information

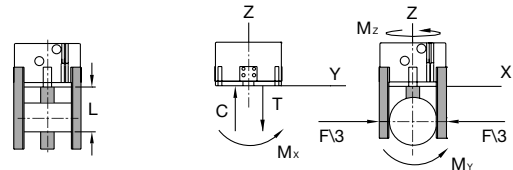
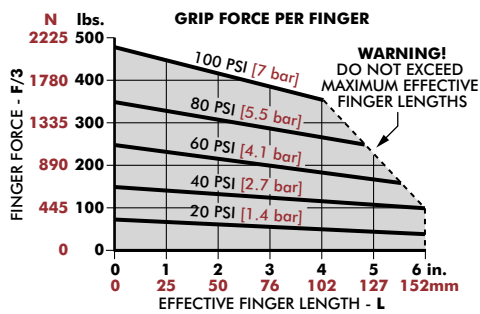

RPC-356	Static	Dynamic
Maximum Tensile T	13445 N [3000 lbs]	4448 N [1000 lbs]
Maximum Compressive C	13445 N [3000 lbs]	4448 N [1000 lbs]
Maximum Moment M_x	452 Nm [4000 in-lbs]	113 Nm [1000 in-lbs]
Maximum Moment M_y	452 Nm [4000 in-lbs]	113 Nm [1000 in-lbs]
Maximum Moment M_z	339 Nm [3000 in-lbs]	85 Nm [750 in-lbs]

*Capacities are per set of jaws and are not simultaneous

3-Jaw Parallel Grippers | Dimensions and Technical Specifications

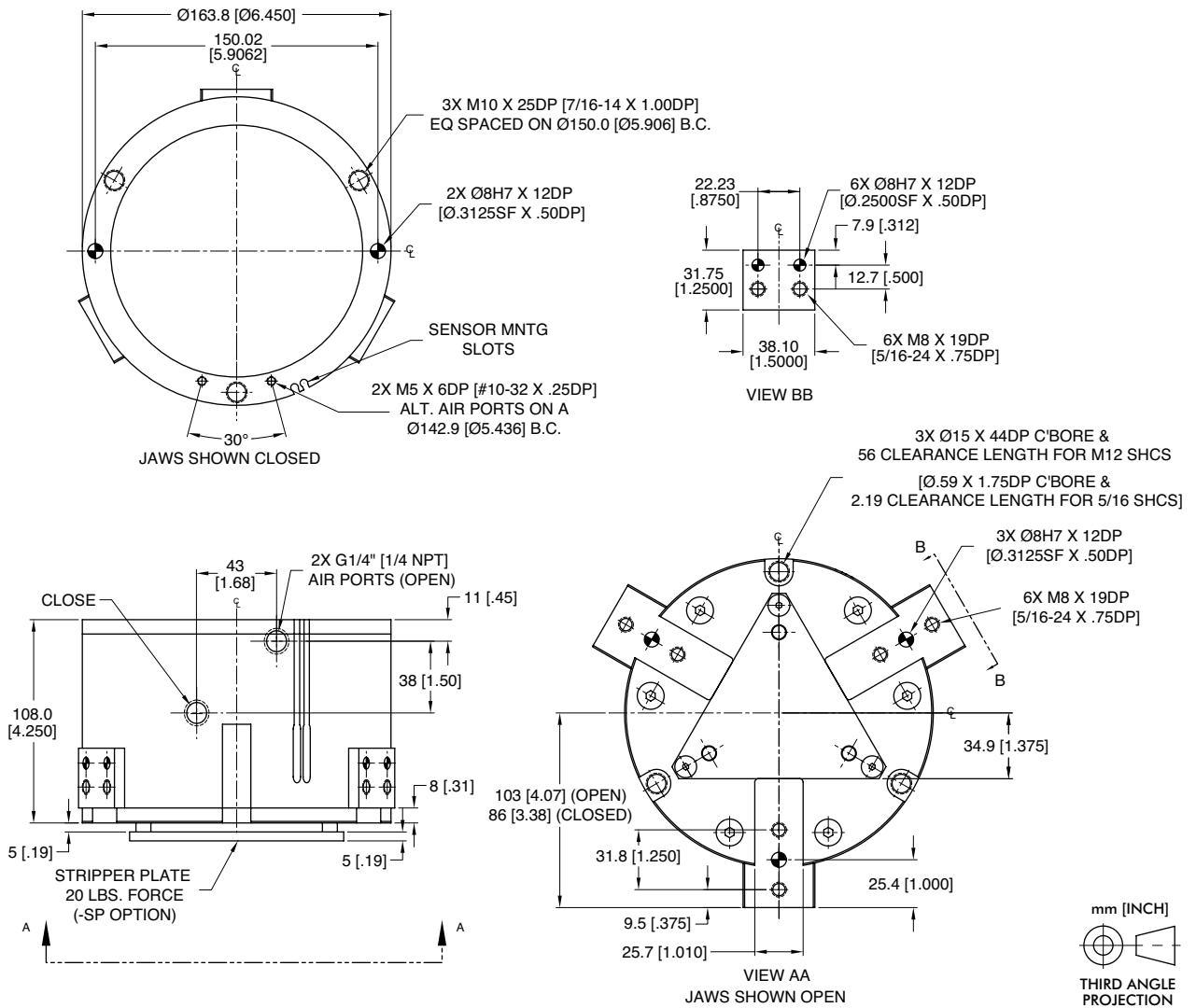

Loading Information

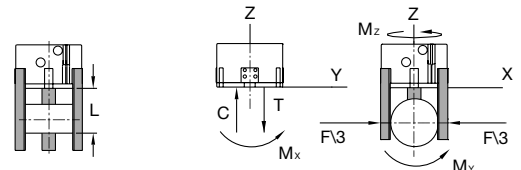
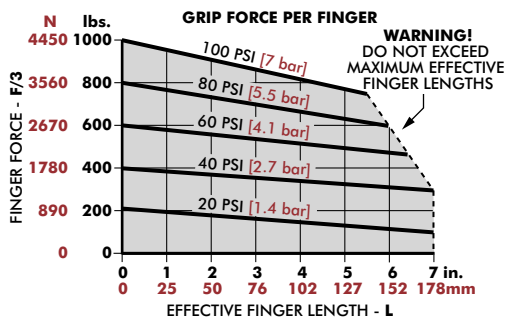





RPC-368	Static	Dynamic
Maximum Tensile T	22241 N [5000 lbs]	6672 N [1500 lbs]
Maximum Compressive C	22241 N [5000 lbs]	6672 N [1500 lbs]
Maximum Moment M_x	791 Nm [7000 in-lbs]	170 Nm [1500 in-lbs]
Maximum Moment M_y	791 Nm [7000 in-lbs]	170 Nm [1500 in-lbs]
Maximum Moment M_z	565 Nm [5000 in-lbs]	113 Nm [1000 in-lbs]

*Capacities are per set of jaws and are not simultaneous

ANGULAR GRIPPERS

Angular Grippers | Product Overview

Model		Stroke Range	Grip Force Range	Operating Environment	Special Features	Page GR-ANG-#
CT		90° per Jaw	272-651 [61-146]	IP43	180 degree Wide Jaw Opening Angle.	3
DCT		90° per Jaw	32-157 [7.2-35]	IP43	180 degree Wide Jaw Opening, spring assist. DIRECTCONNECT	3
RA (CAM) RA (TOGGLE)		15° per Jaw	71-801 [16-180]	IP43	Low Cost, small compact Gripper. Rugged Applications.	13
RUA		31.8° - 38.2° Total	384-7911 [86-1778]	IP54 Using Purge Port	High Force Gripping for Harsh & Rugged Applications. Spring Assist.	27

ANGULAR GRIPPERS

Angular Grippers | DIRECTCONNECT™ Mounting Compatibility Chart

DIRECTCONNECT Modular Direct Mounting System without Adapter Plates

Products can be mounted in multiple positions. Refer to datasheet for complete info.

Slide to Gripper

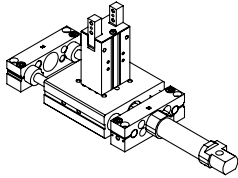

DLB Base Slide to
DCT Angular Gripper

Slide to Gripper

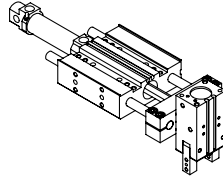

DLT Thruster Slide to
DCT Angular Gripper

Slide to Gripper

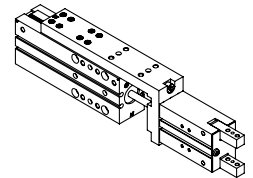

DLM Thruster Slide to
DCT Angular Gripper

DIRECTCONNECT

Mounting Compatibility Chart

DESTACO's DIRECTCONNECT™ technology, allows all components of the system—grippers, rotaries and slides—to be mounted together directly. Look for matching icons on product datasheets for mounting compatibility.

Note: The numbers in the cell represent the metric screw size and basic mounting pattern.

S=Square, R=Rectangle. ie; 5S = M5 Screw with square mounting pattern.

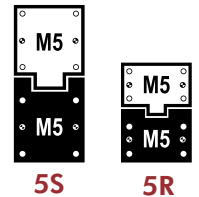

Catalog Models		Grippers	
		DCT-12, 16, 20	DCT-25
Base Slides	DLB-06,08	3R	
	DLB-10,12,16		5R
	DLB-20,25		
Thruster Slides	DLT-06,08	3R	
	DLT-10,12,16	3R	5R
	DLT-20,25		5R
	DLM-07	3R	
	DLM-9,12	3R	5R

CT/DCT & CT-RE/DCT-RE SERIES

Angular Grippers | Features and Benefits | How To Order

Features:

- 180° angular gripper jaw opening for direct feed systems
- Shielded design for working in dirty environments
- Spring assist option maintains grip in case of air pressure loss
- Adjustable 0 to 180° opening angle option.
- Side and bottom gripper mounting
- Multiple air ports, side and top air ports for easy installation

Applications:

- In-line conveying applications
- OEM pick and place machines
- End-of-arm tooling



How To Order

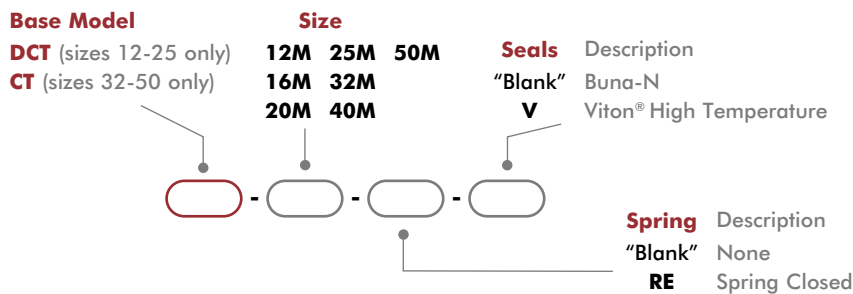

Accessories

Sensor Accessories	Model Numbers	Part Number	Qty/Unit
NPN Magneto Resistive Sensor with M8 Quick Disconnect	All Models	OHSN-017	1-2
PNP Magneto Resistive Sensor with M8 Quick Disconnect	All Models	OHSP-017	1-2
Inductive Sensor Mounting Kit (mounts 2 sensors)	See Datasheet		1
4mm NPN Inductive Sensor with M8 Quick Disconnect*	16M, 20M	OISN-014	1-2
4mm PNP Inductive Sensor M8 with Quick Disconnect*	16M, 20M	OISP-014	1-2
M8 NPN Inductive Sensor with M8 Quick Disconnect*	25M, 32M	OISN-011	1-2
M8 PNP Inductive Sensor with M8 Quick Disconnect*	25M, 32M	OISP-011	1-2
M12 NPN Inductive Sensor with M12 Quick Disconnect*	40M, 50M	OISN-017	1-2
M12 PNP Inductive Sensor with M12 Quick Disconnect*	40M, 50M	OISP-017	1-2
M8 Quick Disconnect 2 Meter Cable Length*	All Models	CABL-010	1-2
M8 Quick Disconnect 5 Meter Cable Length*	All Models	CABL-013	1-2
M12 Quick Disconnect 2 Meter Cable Length*	All Models	CABL-014	1-2
M12 Quick Disconnect 5 Meter Cable Length*	All Models	CABL-018	1-2

Pneumatic Accessories	Model Numbers	Part Number	Qty/Unit
Adjustable Flow Control-M5 Elbow-6mm OD Push-in	12M, 16M, 20M, 25M, 32M	VLVF-008	1-2
Adjustable Flow Control-G1/8 Elbow-6mm OD Push-in	40M, 50M	VLVF-005	1-2

*Sensor and cable sold separately.

CT/DCT & CT-RE/DCT-RE SERIES

Angular Grippers | Technical Specifications

Specifications	Units	12M	12M-RE	16M	16M-RE	20M	20M-RE	25M	25M-RE
Total Rated Grip Force F @ 100 psi [7 bar]	N [lb]	32 [7.2]	40 [9]	70 [16]	87 [19]	112 [25]	141 [32]	157 [35]	199 [45]
Stroke (degrees per finger)		90° per finger (180° total)							
Weight	kg [lbs]	0.09 [0.20]	0.12 [0.26]	0.16 [0.35]	0.20 [0.44]	0.28 [0.62]	0.33 [0.73]	0.49 [1.08]	0.57 [1.26]
Pressure Range w/o Spring	bar [psia]	3-7 [40-100] CT/DCT							
Pressure Range w/ Spring	bar [psi]	4-7 [60-100] CT-RE/DCT-RE							
Ingress Protection Class (IP)		IP43							
Displacement	cm ³ [in ³]	1.92 [0.117]		4.12 [0.251]		7.92 [0.483]		14.9 [0.909]	
Temperature Range (Buna-N seals)	°C [°F]	-35°~80° [-30°~180°]							
Temperature Range (Viton® seals)	°C [°F]	-30°~150° [-20°~300°]							
Actuation (open)	sec	0.06	0.08	0.13	0.15	0.16	0.20	0.21	0.25
Actuation (close)	sec	0.06	0.05	0.13	0.12	0.16	0.14	0.21	0.19
Accuracy	mm [in]	±0.07 [±0.0028]				±0.08 [±0.003]			
Repeatability	mm [in]	±0.05 [±0.002]							
Valve to Actuate Double Acting		4-way, 2-position CT/DCT							
Valve to Actuate Double Acting Spring Assist		4-way, 2-position CT-RE/DCT-RE							
Valve to Actuate Single Acting		3-way, 2-position CT-RE/DCT-RE							

Specifications	Units	32M	32M-RE	40M	40M-RE	50M	50M-RE
Total Rated Grip Force F @ 100 psi [7 bar]	N [lb]	272 [61]	353 [79]	446 [100]	592 [133]	651 [146]	893 [201]
Stroke (degrees per finger)		90° per finger (180° total)					
Weight	kg [lbs]	0.72 [1.59]	0.83 [1.83]	1.18 [2.60]	1.39 [3.06]	1.82 [4.01]	2.21 [4.87]
Pressure Range w/o Spring	bar [psia]	3-7 [40-100] CT/DCT					
Pressure Range w/ Spring	bar [psi]	4-7 [60-100] CT-RE/DCT-RE					
Ingress Protection Class (IP)		IP43					
Displacement	cm ³ [in ³]	28.6 [1.745]		52 [3.173]		92 [5.614]	
Temperature Range (Buna-N seals)	°C [°F]	-35°~80° [-30°~180°]					
Temperature Range (Viton® seals)	°C [°F]	-30°~150° [-20°~300°]					
Actuation (open)	sec	0.29	0.35	0.41	0.47	0.46	0.54
Actuation (close)	sec	0.29	0.26	0.41	0.38	0.46	0.42
Accuracy	mm [in]	±0.08 [±0.003]			±0.09 [±0.0036]		
Repeatability	mm [in]	±0.05 [±0.002]					
Valve to Actuate Double Acting		4-way, 2-position CT/DCT					
Valve to Actuate Double Acting Spring Assist		4-way, 2-position CT-RE/DCT-RE					
Valve to Actuate Single Acting		3-way, 2-position CT-RE/DCT-RE					

DCT-12, -12-RE



Angular Grippers | Dimensions and Technical Specifications

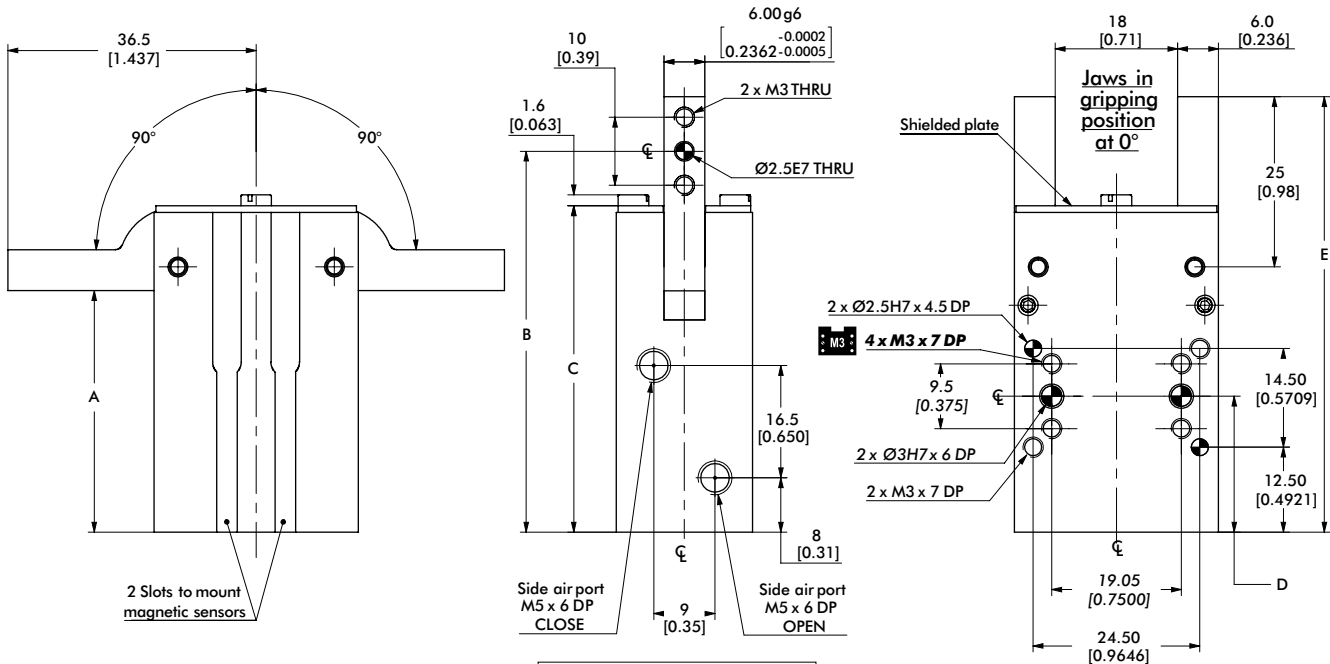

NOTE: Jaws have to be designed for a 0° gripping position (parallel jaws). Jaws will close 1.5° past parallel. To limit shocks at the end of an opening or closing stroke, it is highly recommended to design jaws with minimal inertia (as light and short as possible). Flow Controls make it possible to reduce the rotation speed and are highly recommended.

Our grippers are supplied with open side air ports and top air ports plugged. When operating top air ports, produce manifold sealing as shown.

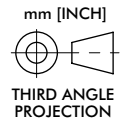
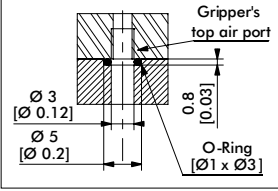

Model	A	B	C	D	E
DCT-12	35.5 [1.398]	56.00 [2.2047]	48 [1.89]	20.00 [0.7874]	64 [2.52]
DCT-12-RE	51.5 [2.028]	72.00 [2.8346]	64 [2.52]	35.00 [1.3780]	80 [3.15]

Dimensions in mm [in]

Mounting Accessories	Order #
Adjustment Stop Kit (1 shielded plate, 1 stop)	KP-DCT12-BR

Seal Repair Kits	Order #
Buna-N Seal Repair Kit	SLKT-159
Viton® Seal Repair Kit	SLKT-159V

Loading Information

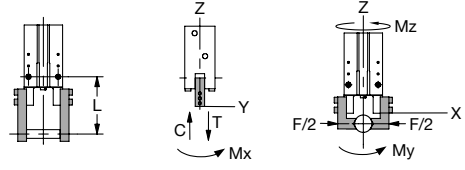
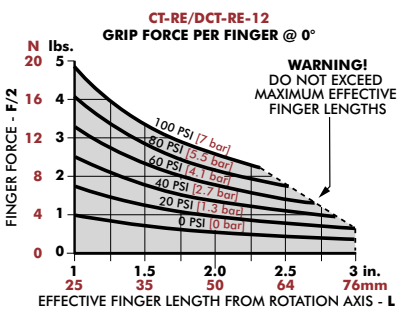
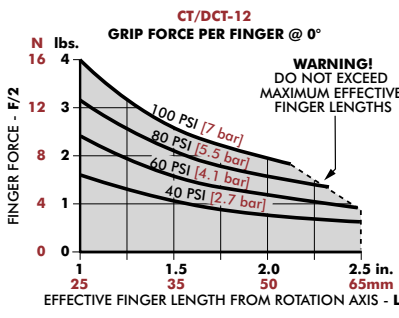

Static	
Maximum Tensile T	47 N [11 lbs]
Maximum Compressive C	47 N [11 lbs]
Maximum Moment M_x	1.1 Nm [10 in-lbs]
Maximum Moment M_y	1.1 Nm [10 in-lbs]
Maximum Moment M_z	1.1 Nm [10 in-lbs]

*Capacities are per set of jaws and are not simultaneous

Angular Grippers | Dimensions and Technical Specifications

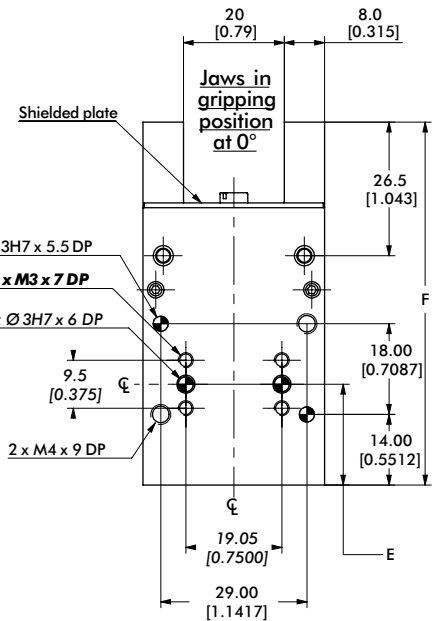
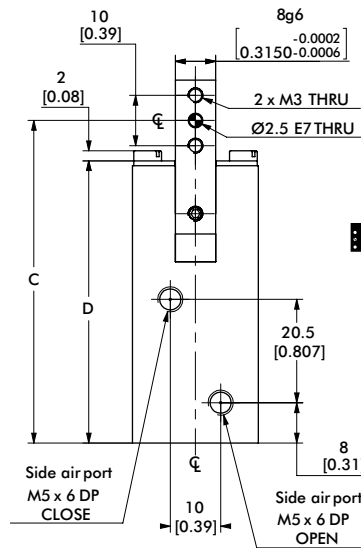
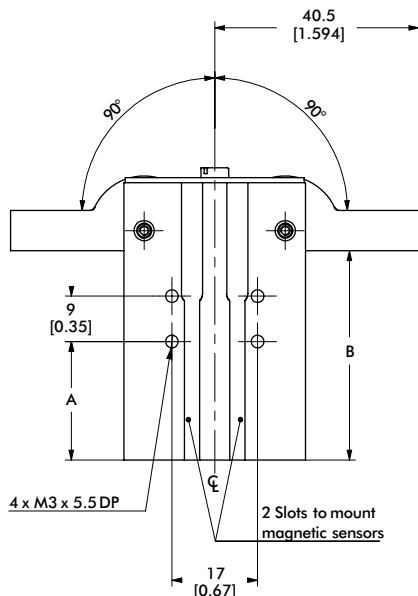

NOTE: Jaws have to be designed for a 0° gripping position (parallel jaws). Jaws will close 1.5° past parallel. To limit shocks at the end of an opening or closing stroke, it is highly recommended to design jaws with minimal inertia (as light and short as possible). Flow Controls make it possible to reduce the rotation speed and are highly recommended.

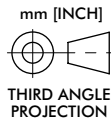
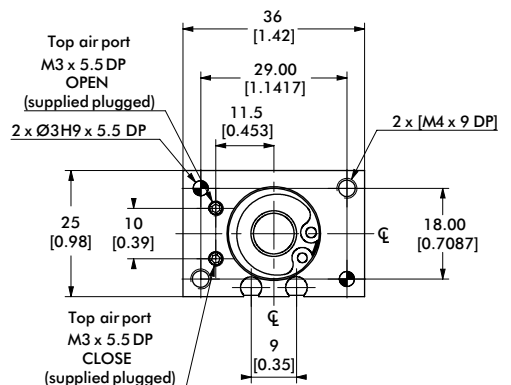
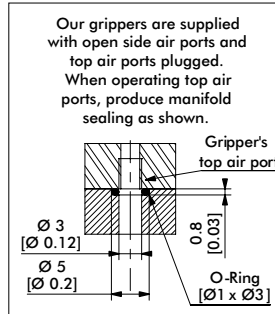

Mounting Accessories		Order #
Inductive Sensor Mounting Kit (mounts 2 sensors)		SDCT-16-20
Adjustment Stop Kit (1 shielded plate, 1 stop)		KP-DCT16-BR
Seal Repair Kits		Order #
Buna-N Seal Repair Kit		SLKT-160
Viton® Seal Repair Kit		SLKT-160V

Model	A	B	C	D	E	F
DCT-16	23.5 [0.925]	41.5 [1.634]	64.00 [2.5197]	56 [2.20]	20.00 [0.7874]	72 [2.83]
DCT-16-RE	38.5 [1.516]	56.5 [2.224]	79.00 [3.1102]	71 [2.80]	35.00 [1.3780]	87 [3.43]

Dimensions in mm [in]

Loading Information

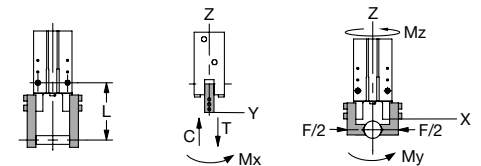
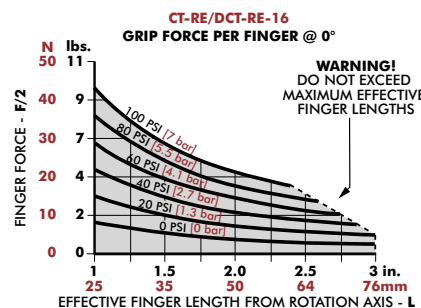
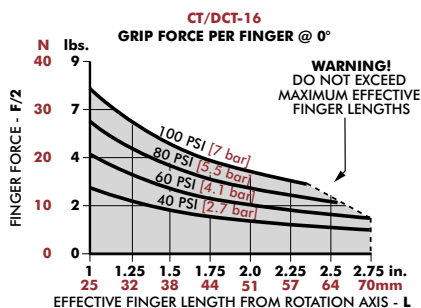

Static	
Maximum Tensile T	90 N [20 lbs]
Maximum Compressive C	90 N [20 lbs]
Maximum Moment M_x	2.9 Nm [26 in-lbs]
Maximum Moment M_y	2.9 Nm [26 in-lbs]
Maximum Moment M_z	2.9 Nm [26 in-lbs]

*Capacities are per set of jaws and are not simultaneous

Angular Grippers | Dimensions and Technical Specifications

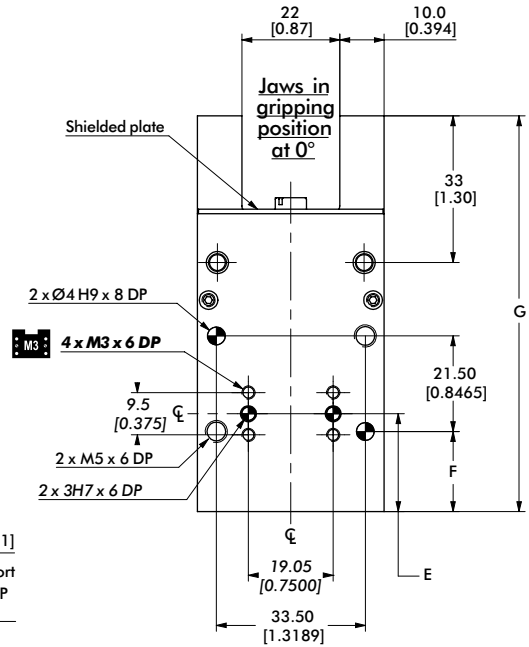
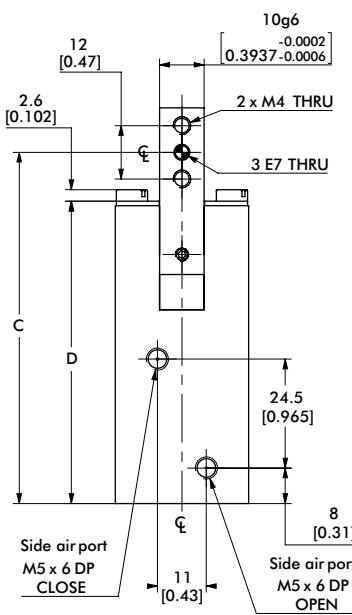
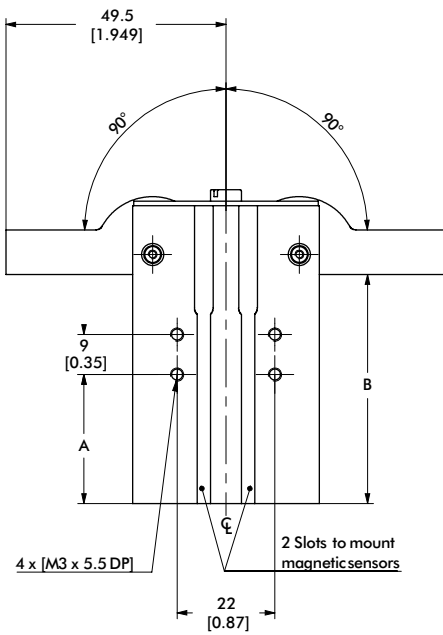

NOTE: Jaws have to be designed for a 0° gripping position (parallel jaws). Jaws will close 1.5° past parallel. To limit shocks at the end of an opening or closing stroke, it is highly recommended to design jaws with minimal inertia (as light and short as possible). Flow Controls make it possible to reduce the rotation speed and are highly recommended.

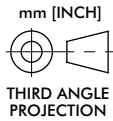
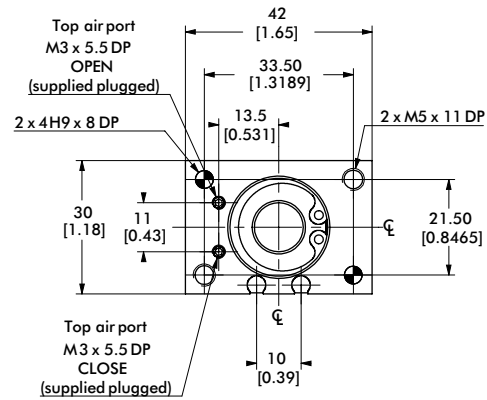
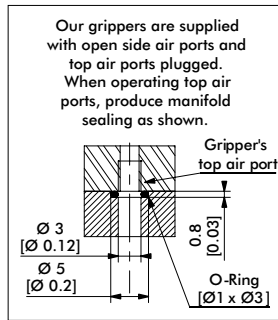

Model	A	B	C	D	E	F	G
DCT-20	29 [1.14]	51.5 [2.028]	79.00 [3.1102]	68 [2.68]	22.00 [0.8661]	18.00 [0.7087]	89 [3.50]
DCG/CT-20-RE	47 [1.85]	66.5 [2.618]	94.00 [3.7008]	83 [3.27]	39.00 [1.5354]	20.00 [0.7874]	104 [4.09]

Dimensions in mm [in]

Mounting Accessories	Order #
Inductive Sensor Mounting Kit (mounts 2 sensors)	SDCT-16-20
Adjustment Stop Kit (1 shielded plate, 1 stop)	KP-DCT20-BR
Seal Repair Kits	Order #
Buna-N Seal Repair Kit	SLKT-161
Viton® Seal Repair Kit	SLKT-161V

Loading Information

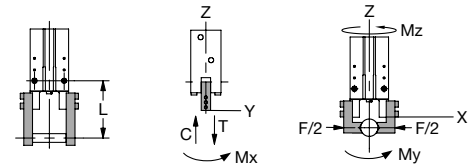
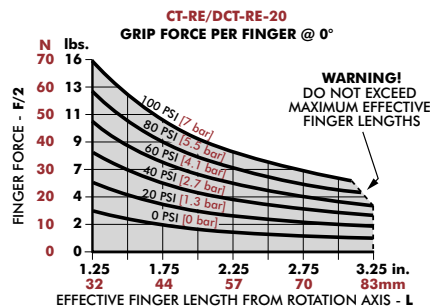
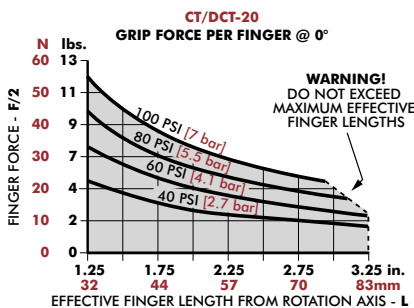

Static	
Maximum Tensile T	150 N [34 lbs]
Maximum Compressive C	150 N [34 lbs]
Maximum Moment M_x	6 Nm [53 in-lbs]
Maximum Moment M_y	6 Nm [53 in-lbs]
Maximum Moment M_z	6 Nm [53 in-lbs]

ⁱCapacities are per set of jaws and are not simultaneous

Angular Grippers | Dimensions and Technical Specifications

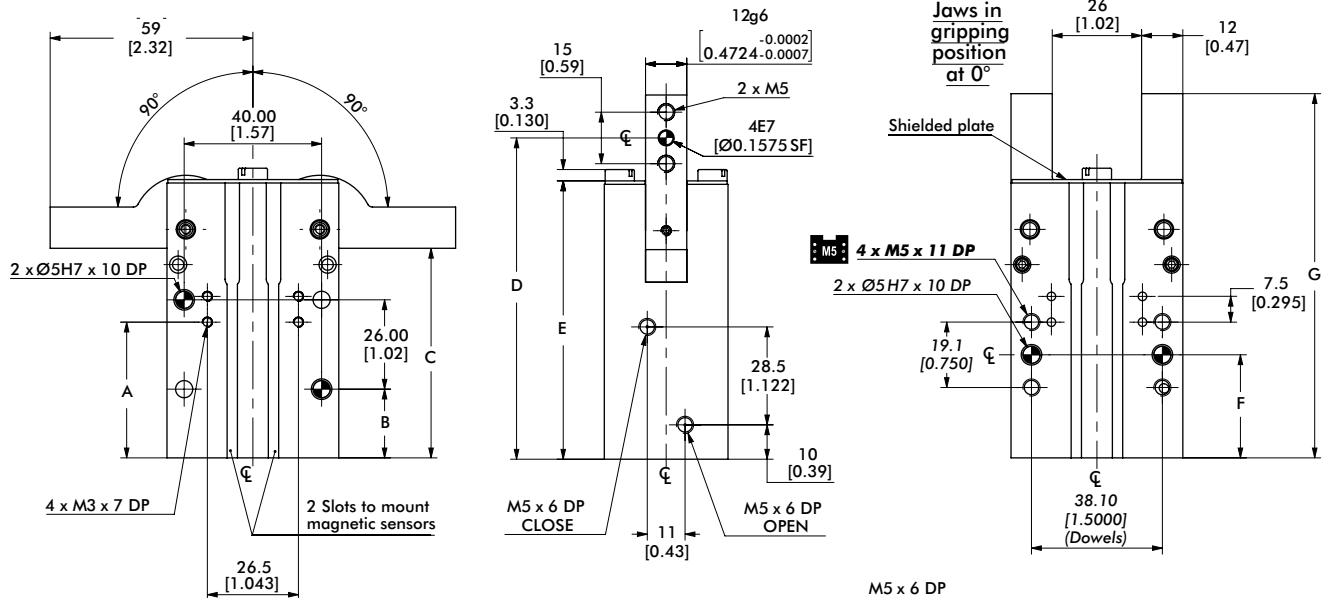

NOTE: Jaws have to be designed for a 0° gripping position (parallel jaws). Jaws will close 1.5° past parallel. To limit shocks at the end of an opening or closing stroke, it is highly recommended to design jaws with minimal inertia (as light and short as possible). Flow Controls make it possible to reduce the rotation speed and are highly recommended.

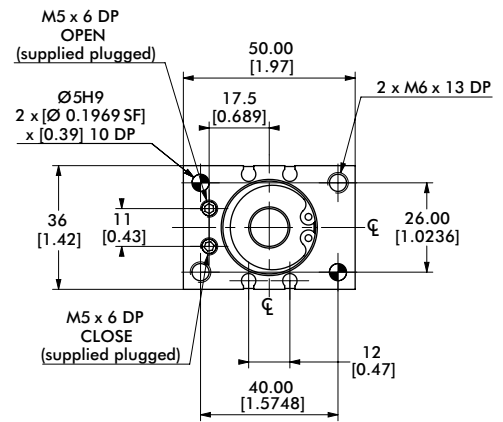
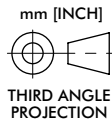
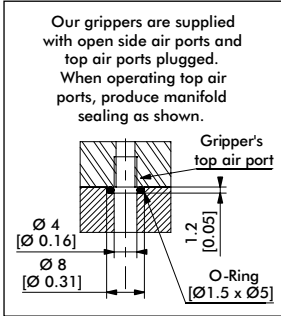

Model	A	B	C	D	E	F	G
DCT-25	39.5 [1.555]	20.00 [0.79]	61 [2.40]	93.50 [3.6811]	81 [3.19]	30.00 [1.1811]	106 [4.17]
DCT-25-RE	60.5 [2.382]	25.00 [0.98]	82 [3.23]	114.50 [4.5079]	102 [4.02]	51.00 [2.0079]	127 [5.00]

Dimensions in mm [in]

Mounting Accessories	Order #
Inductive Sensor Mounting Kit (mounts 2 sensors)	SDCT-25-32
Adjustment Stop Kit (1 shielded plate, 1 stop)	KP-DCT25-BR
Seal Repair Kits	Order #
Buna-N Seal Repair Kit	SLKT-162
Viton® Seal Repair Kit	SLKT-162V

Loading Information

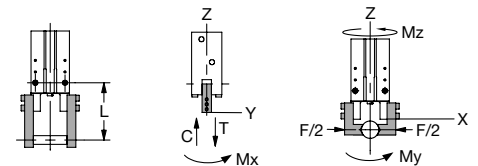
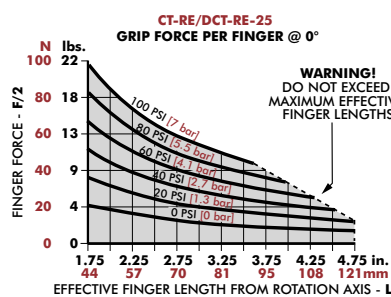
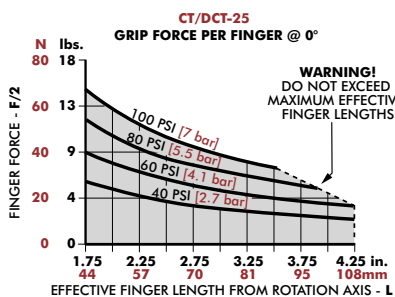

Static	
Maximum Tensile T	205 N [46 lbs]
Maximum Compressive C	205 N [46 lbs]
Maximum Moment M_x	10 Nm [89 in-lbs]
Maximum Moment M_y	10 Nm [89 in-lbs]
Maximum Moment M_z	10 Nm [89 in-lbs]

*Capacities are per set of jaws and are not simultaneous

CT-32/ -32-RE

Angular Grippers | Dimensions and Technical Specifications

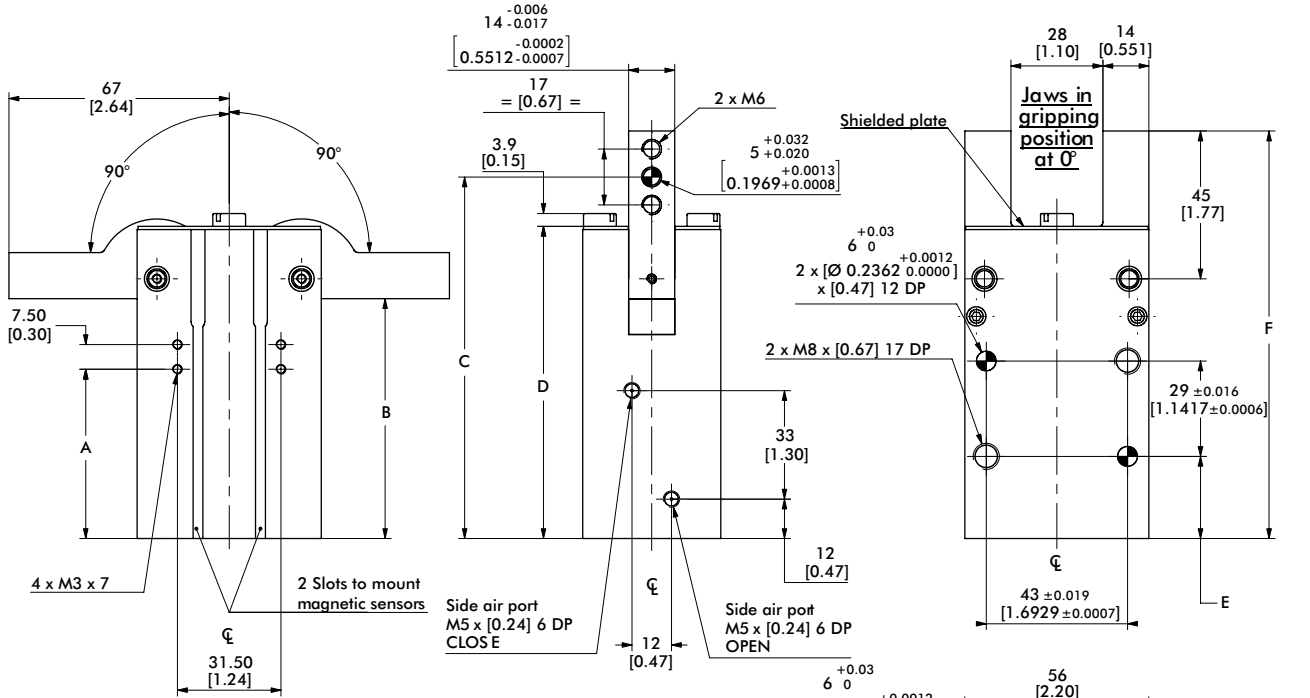

NOTE: Jaws have to be designed for a 0° gripping position (parallel jaws). Jaws will close 1.5° past parallel. To limit shocks at the end of an opening or closing stroke, it is highly recommended to design jaws with minimal inertia (as light and short as possible). Flow Controls make it possible to reduce the rotation speed and are highly recommended.

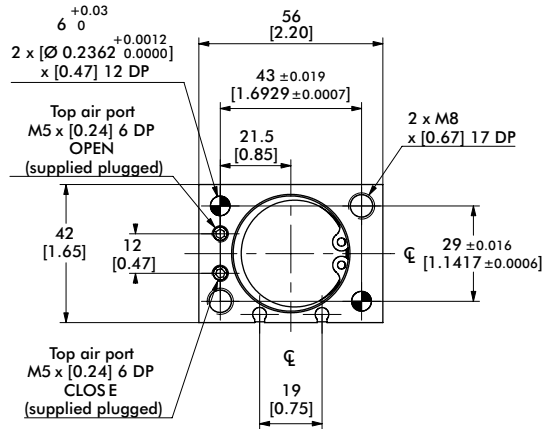
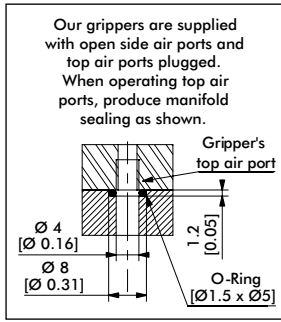
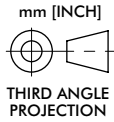

Model	A	B	C	D	E	F
CT-32	51.50 [2.03]	73 [2.87]	110 [4.3307]	95 [3.74]	25 [0.9843]	124 [4.88]
CT-32-RE	72.50 [2.85]	94 [3.70]	131 [5.1575]	116 [4.57]	30 [1.811]	145 [5.71]

Dimensions in mm [in]

Mounting Accessories	Order #
Inductive Sensor Mounting Kit (mounts 2 sensors)	SDCT-25-32
Adjustment Stop Kit (1 shielded plate, 1 stop)	KP-CT32-BR
Seal Repair Kits	Order #
Buna-N Seal Repair Kit	SLKT-163
Viton® Seal Repair Kit	SLKT-163V

Loading Information

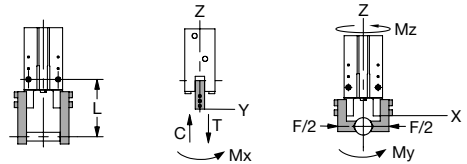
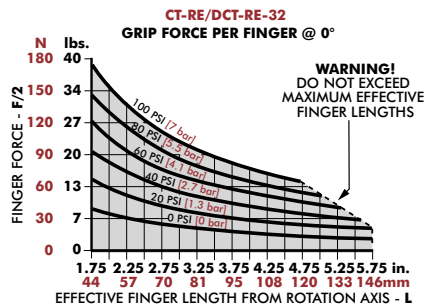
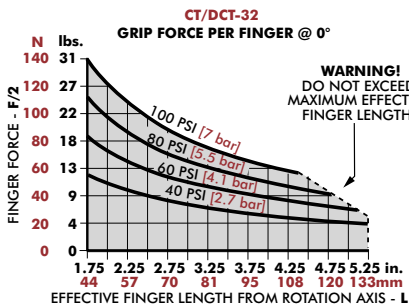

	Static
Maximum Tensile T	288 N [65 lbs]
Maximum Compressive C	288 N [65 lbs]
Maximum Moment M_x	16 Nm [142 in-lbs]
Maximum Moment M_y	16 Nm [142 in-lbs]
Maximum Moment M_z	16 Nm [142 in-lbs]

^cCapacities are per set of jaws and are not simultaneous

Angular Grippers | Dimensions and Technical Specifications

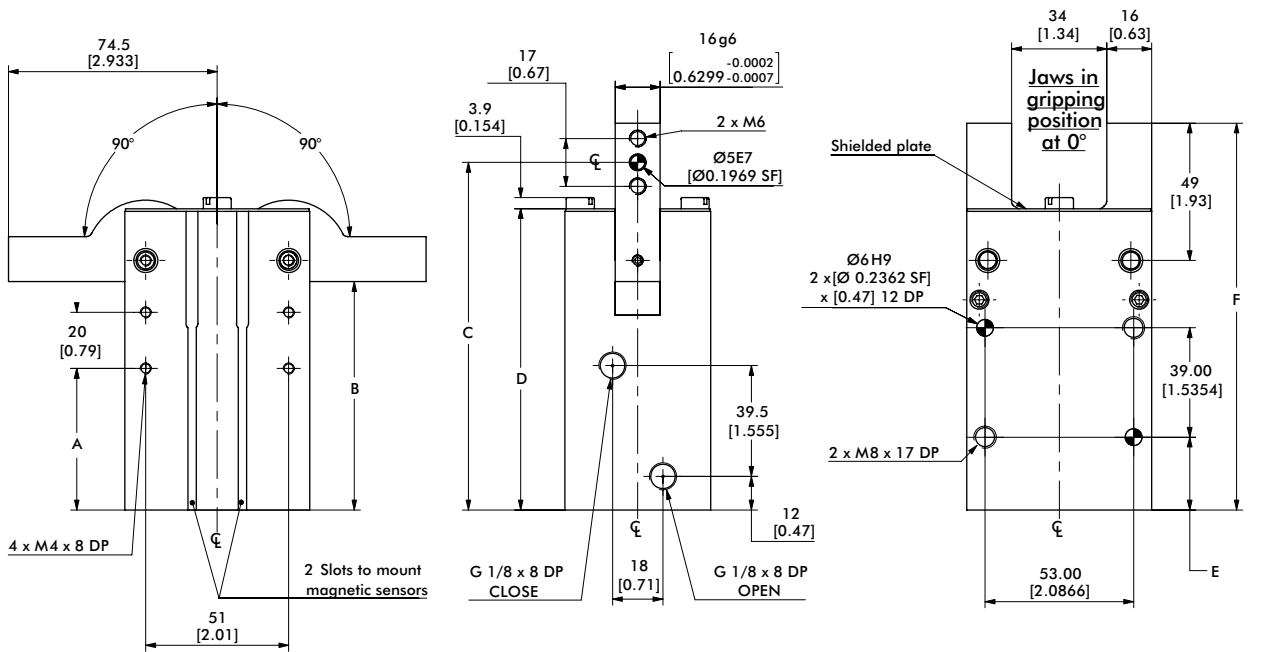

NOTE: Jaws have to be designed for a 0° gripping position (parallel jaws). Jaws will close 1.5° past parallel. To limit shocks at the end of an opening or closing stroke, it is highly recommended to design jaws with minimal inertia (as light and short as possible). Flow Controls make it possible to reduce the rotation speed and are highly recommended.

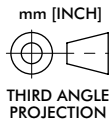
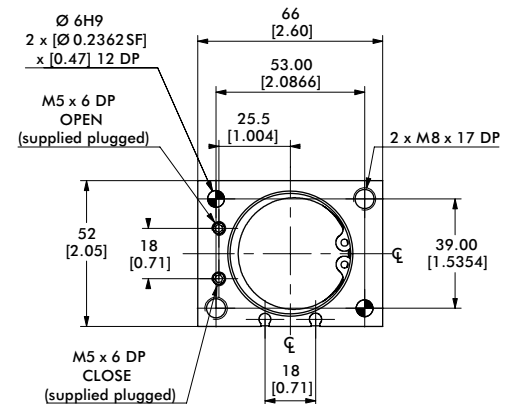
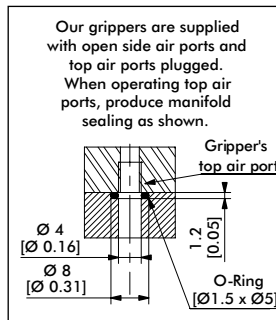

Model	A	B	C	D	E	F
CT-40	50.5 [1.988]	81.5 [3.209]	124.00 [4.8819]	107.5 [4.232]	26.00 [1.0236]	138 [5.43]
CT-40-RE	78 [3.07]	109 [4.29]	151.50 [5.9646]	135 [5.31]	32.00 [1.2598]	165.5 [6.516]

Dimensions in mm [in]

Mounting Accessories	Order #
Inductive Sensor Mounting Kit (mounts 2 sensors)	SDCT-40-63
Adjustment Stop Kit (1 shielded plate, 1 stop)	KP-CT40-BR

Seal Repair Kits	Order #
Buna-N Seal Repair Kit	SLKT-164
Viton® Seal Repair Kit	SLKT-164V

Loading Information

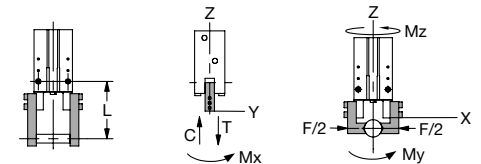
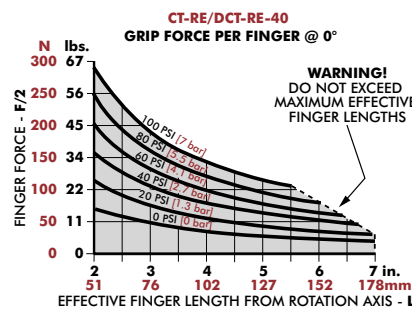
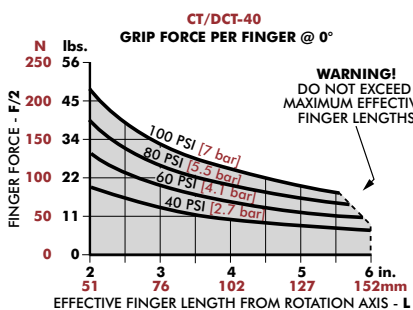

	Static
Maximum Tensile T	420 N [94 lbs]
Maximum Compressive C	420 N [94 lbs]
Maximum Moment M_x	22 Nm [195 in-lbs]
Maximum Moment M_y	22 Nm [195 in-lbs]
Maximum Moment M_z	22 Nm [195 in-lbs]

*Capacities are per set of jaws and are not simultaneous

CT-50/ -50-RE

Angular Grippers | Dimensions and Technical Specifications

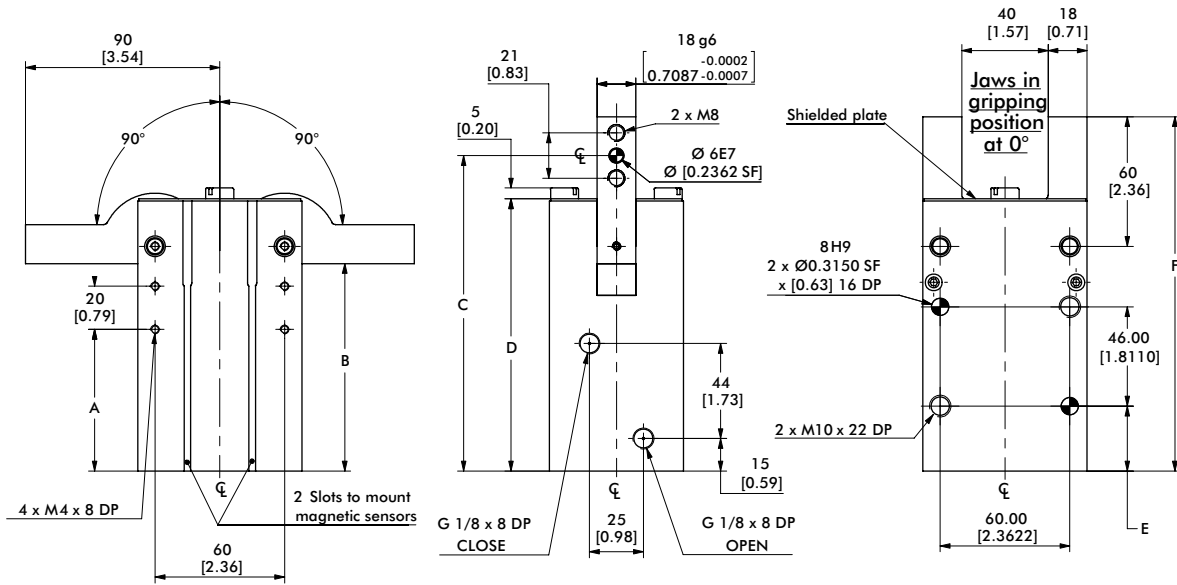

NOTE: Jaws have to be designed for a 0° gripping position (parallel jaws). Jaws will close 1.5° past parallel. To limit shocks at the end of an opening or closing stroke, it is highly recommended to design jaws with minimal inertia (as light and short as possible). Flow Controls make it possible to reduce the rotation speed and are highly recommended.

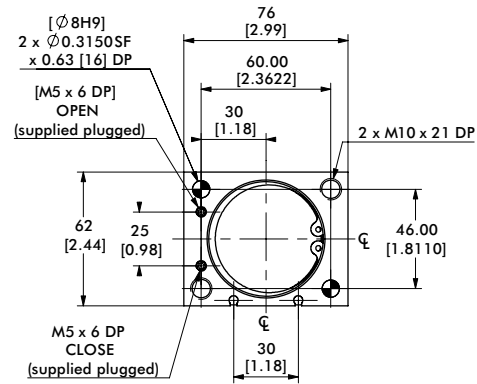
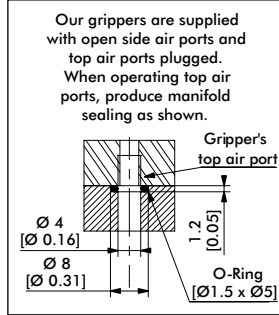
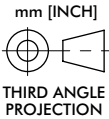

Model	A	B	C	D	E	F
CT-50	65.5 [2.579]	96 [3.78]	146.00 [5.7480]	126 [4.96]	30.00 [1.1811]	164 [6.46]
CT-50-RE	102.50 [4.035]	133 [5.24]	183.00 [7.2047]	163 [6.42]	40.00 [1.5748]	201 [7.91]

Dimensions in mm [in]

Mounting Accessories	Order #
Inductive Sensor Mounting Kit (mounts 2 sensors)	SDCT-40-63
Adjustment Stop Kit (1 shielded plate, 1 stop)	KP-CT50-BR
Seal Repair Kits	Order #
Buna-N Seal Repair Kit	SLKT-165
Viton® Seal Repair Kit	SLKT-165V

Loading Information

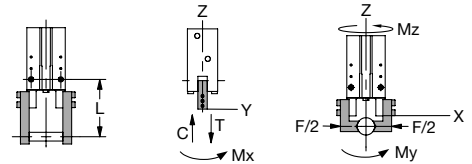
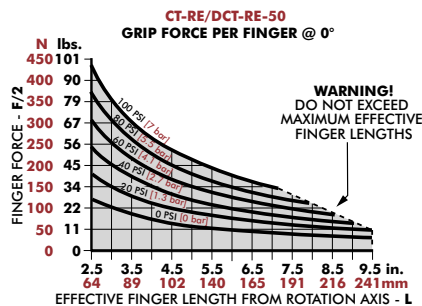
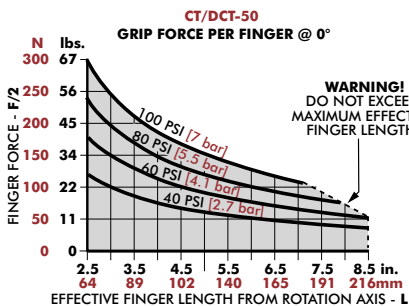

Static	
Maximum Tensile T	490 N [110 lbs]
Maximum Compressive C	490 N [110 lbs]
Maximum Moment M_x	30 Nm [266 in-lbs]
Maximum Moment M_y	30 Nm [266 in-lbs]
Maximum Moment M_z	30 Nm [266 in-lbs]

ⁱCapacities are per set of jaws and are not simultaneous

RA (CAM DRIVEN) SERIES

Angular Grippers | Features and Benefits | How To Order

Features:

- Highly reliable rugged general purpose gripper
- High grip force to size ratio due to cam driven design
- Fingers can be mounted on the side or top of jaws.
- Optional Viton® seals for high temperatures
-30°C to +150°C [-20°F to +300°F]
- Use up to 2 magneto resistive sensors

Applications:

- Industrial assembly machines
- OEM pick and place machines
- General purpose gripping

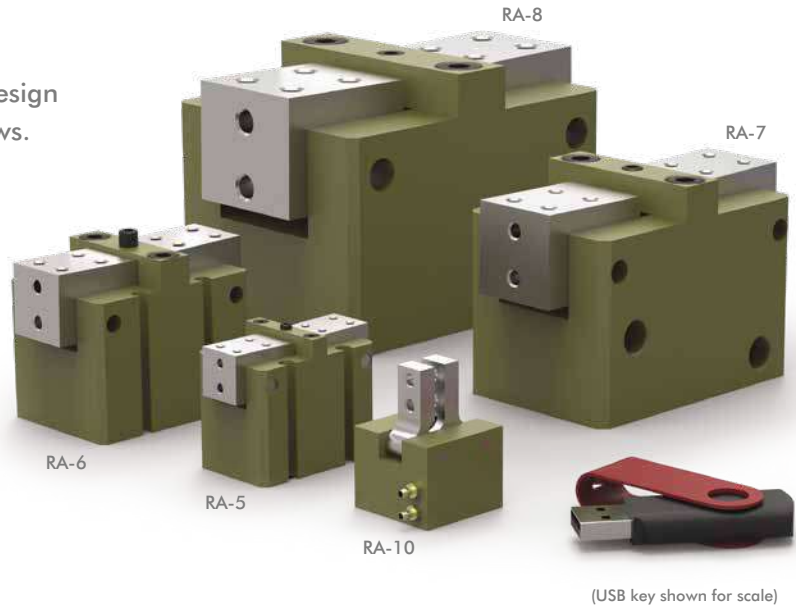

(USB key shown for scale)

How To Order

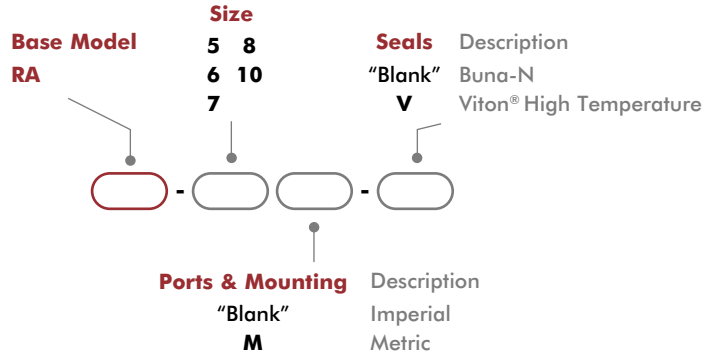

Accessories

Sensor Accessories	Model Numbers	Part Number	Qty/Unit
NPN Magneto Resistive Sensor with Quick Disconnect*	5, 6, 7, 8	OHSN-017	1-2
PNP Magneto Resistive Sensor with Quick Disconnect*	5, 6, 7, 8	OHSP-017	1-2
NPN Magneto Resistive Sensor 90° with Quick Disconnect*	5, 6, 7, 8	OHSN-011	1-2
PNP Magneto Resistive Sensor 90° with Quick Disconnect*	5, 6, 7, 8	OHSP-011	1-2
Quick Disconnect 2 Meter Cable Length*	5, 6, 7, 8	CABL-010	1-2
Quick Disconnect 5 Meter Cable Length*	5, 6, 7, 8	CABL-013	1-2

Pneumatic Accessories	Model Numbers	Part Number	Qty/Unit
Fail Safe Valve (Imperial)	5, 6	OFSV-001	1
Fail Safe Valve (Metric)	5, 6	OFSV-004	1
Fail Safe Valve (Imperial)	7, 8	OFSV-002	1
Fail Safe Valve (Metric)	7, 8	OFSV-005	1

* Sensor and cable sold separately.

RA (CAM DRIVEN) SERIES

Angular Grippers | Technical Specifications

Specifications	Units	5	6	7
Total Rated Grip Force F @ 7 bar [100 psi]	N [lbs]	89 [20]	196 [44]	534 [120]
Total Stroke		15° per finger (30° total)		
Open Stroke Adjustment		15° per finger (30° total)		10° per finger (20° total)
Weight	kg [lbs]	0.11 [0.25]	0.31 [0.69]	0.8 [1.8]
Pressure Range	bar [psi]	3-7 [40-100]		
Ingress Protection Class (IP)		IP43		
Displacement	cm ³ [in ³]	2.1 [0.13]	4.9 [0.300]	9.8 [0.601]
Temperature Range (Buna-N seals)	°C [°F]	-35°~80° [-30°~180°]		
Temperature Range (Viton® seals)	°C [°F]	-30°~150° [-20°~300°]		
Actuation	sec	0.10	0.11	0.15
Accuracy	mm [in]	±0.13 [±0.005]		
Repeatability	mm [in]	±0.08 [±0.003]		
Valve to Actuate		4-way, 2-position		

Specifications	Units	8	10
Total Rated Grip Force F @ 7 bar [100 psi]	N [lbs]	801 [180]	71 [16]
Total Stroke		15° per finger (30° total)	
Open Stroke Adjustment		10° per finger (20° total)	--
Weight	kg [lbs]	2.1 [4.6]	0.03 [0.063]
Pressure Range	bar [psi]	3-7 [40-100]	
Ingress Protection Class (IP)		IP43	
Displacement	cm ³ [in ³]	21.6 [1.320]	0.4 [0.026]
Temperature Range (Buna-N seals)	°C [°F]	-35°~80° C [-30°~180° F]	
Temperature Range (Viton® seals)	°C [°F]	-30°~150° C [-20°~300° F]	
Actuation	sec	0.23	0.08
Accuracy	mm [in]	±0.13 [±0.005]	±0.08 [±0.003]
Repeatability	mm [in]	±0.08 [±0.003]	±0.03 [±0.001]
Valve to Actuate		4-way, 2-position	

RA-5

Angular Grippers | Dimensions and Technical Specifications

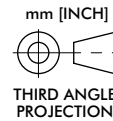
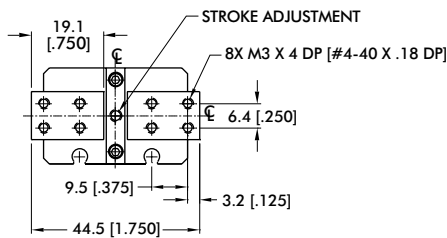
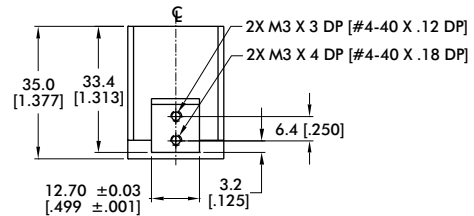
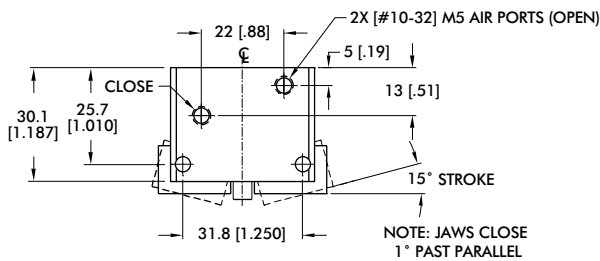
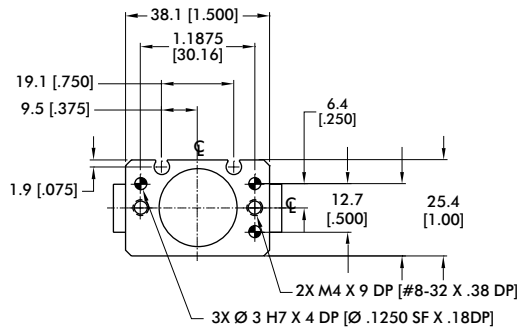

Seal Repair Kits	Order #
Buna-N Seal Repair Kit	SLKT-022
Viton® Seal Repair Kit	SLKT-022V

Loading Information

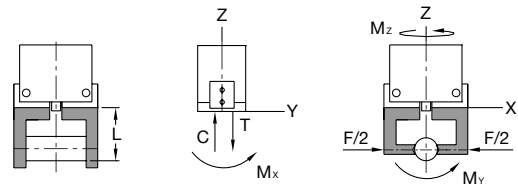
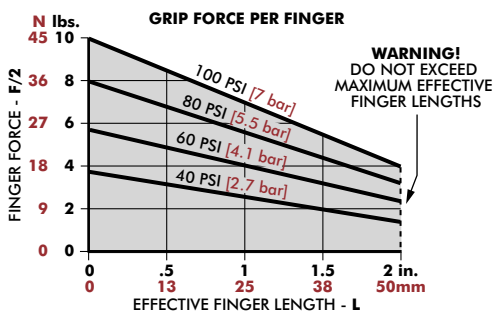

RA-5	Static
Maximum Tensile T	44 N [10 lbs]
Maximum Compressive C	44 N [10 lbs]
Maximum Moment M_x	1.1 Nm [10 in-lbs]
Maximum Moment M_y	1.1 Nm [10 in-lbs]
Maximum Moment M_z	1.1 Nm [10 in-lbs]

[†]Capacities are per set of jaws and are not simultaneous

Angular Grippers | Dimensions and Technical Specifications

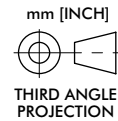
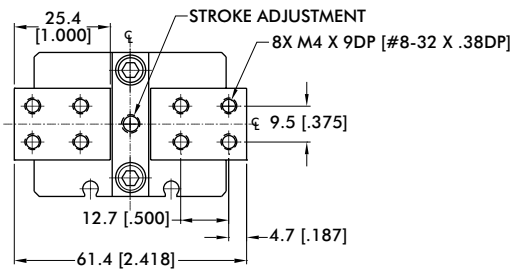
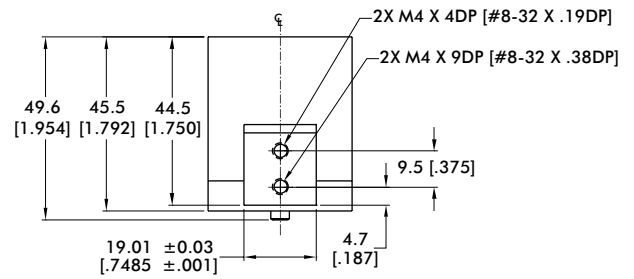
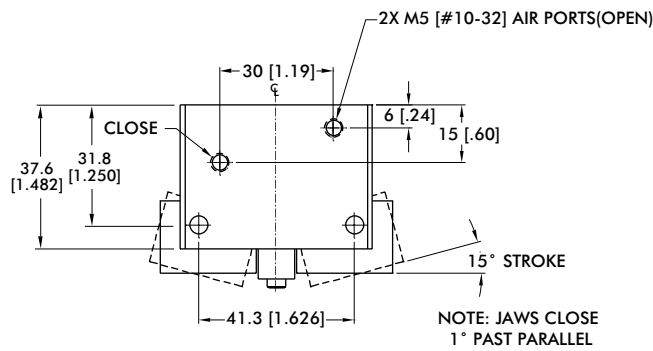
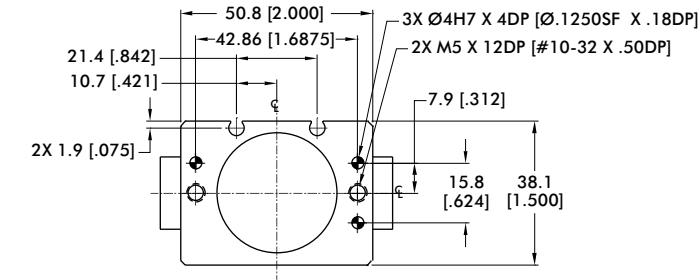

Seal Repair Kits	Order #
Buna-N Seal Repair Kit	SLKT-023
Viton® Seal Repair Kit	SLKT-023V

Loading Information

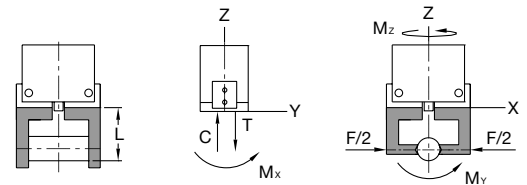
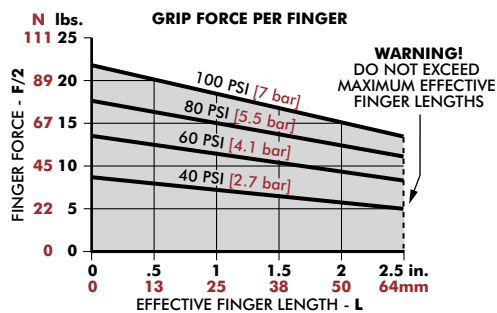

RA-6	Static
Maximum Tensile T	89 N [20 lbs]
Maximum Compressive C	89 N [20 lbs]
Maximum Moment M_x	2.3 Nm [20 in-lbs]
Maximum Moment M_y	2.3 Nm [20 in-lbs]
Maximum Moment M_z	2.3 Nm [20 in-lbs]

*Capacities are per set of jaws and are not simultaneous

RA-7

Angular Grippers | Dimensions and Technical Specifications

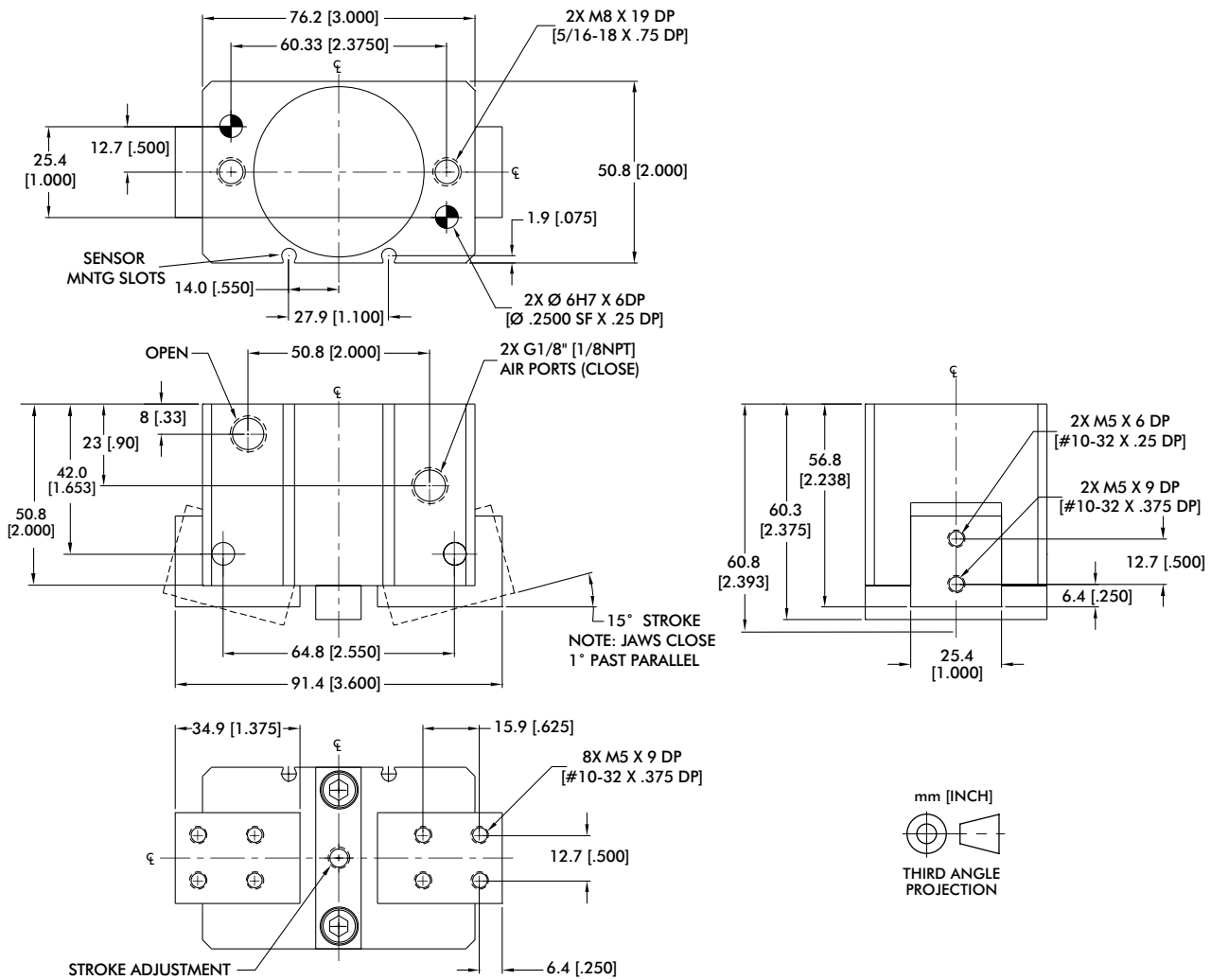

Seal Repair Kits	Order #
Buna-N Seal Repair Kit	SLKT-118
Viton® Seal Repair Kit	SLKT-118V

Loading Information

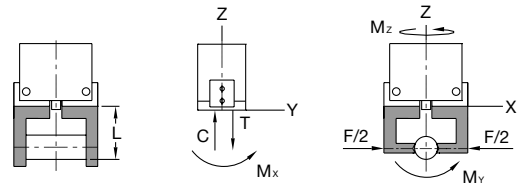
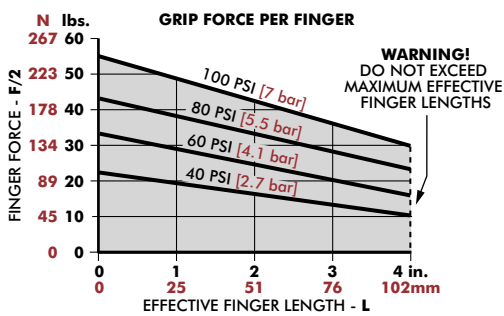

RA-7	Static
Maximum Tensile T	267 N [60 lbs]
Maximum Compressive C	267 N [60 lbs]
Maximum Moment M_x	6.8 Nm [60 in-lbs]
Maximum Moment M_y	6.8 Nm [60 in-lbs]
Maximum Moment M_z	6.8 Nm [60 in-lbs]

[†]Capacities are per set of jaws and are not simultaneous

Angular Grippers | Dimensions and Technical Specifications

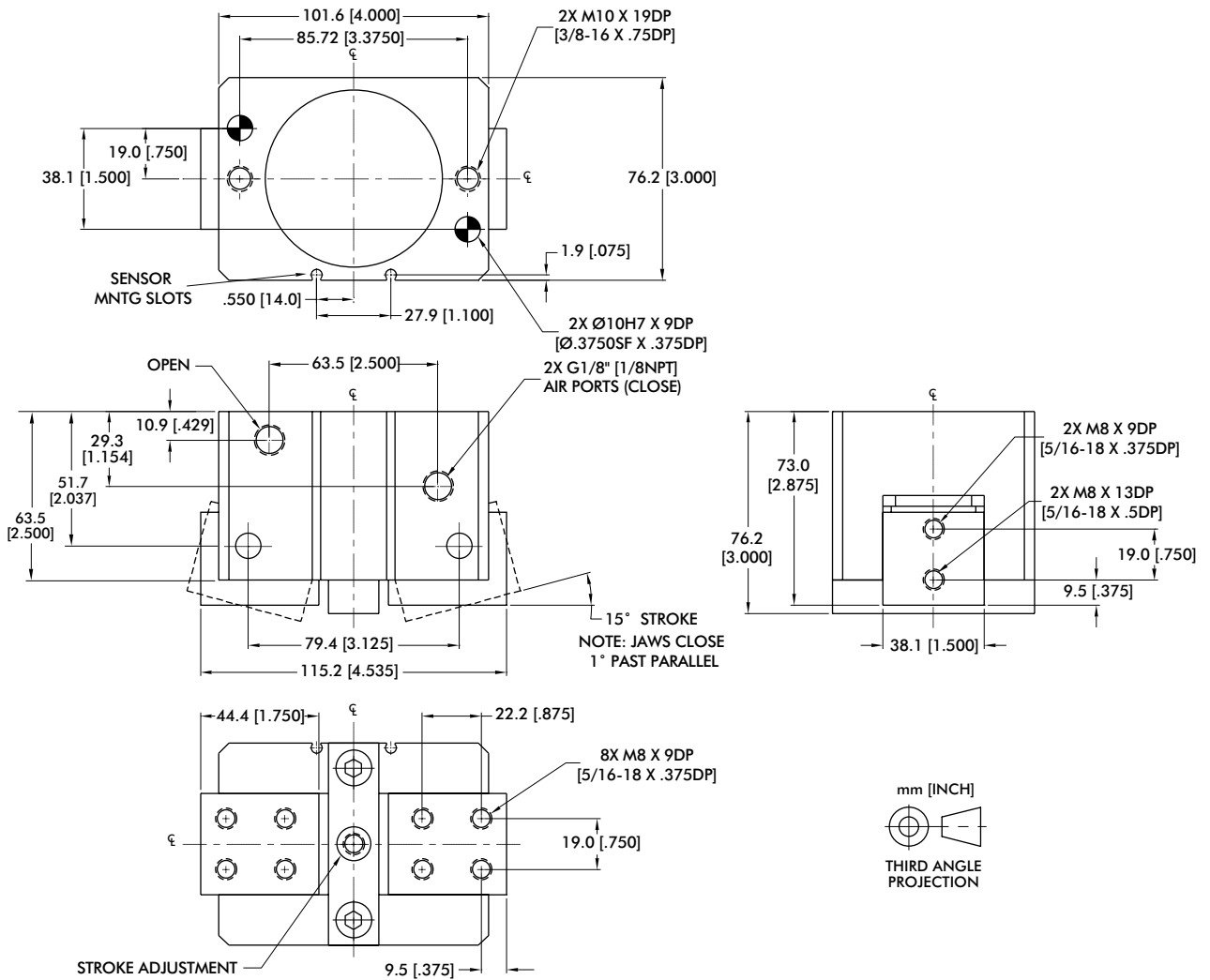

Seal Repair Kits	Order #
Buna-N Seal Repair Kit	SLKT-119
Viton® Seal Repair Kit	SLKT-119V

Loading Information

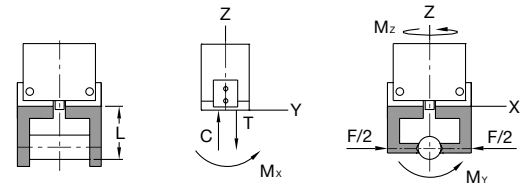
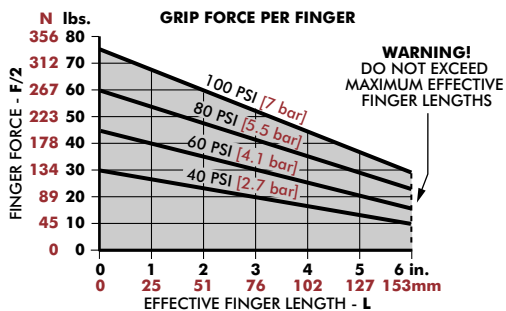

RA-8	Static
Maximum Tensile T	400 N [90 lbs]
Maximum Compressive C	400 N [90 lbs]
Maximum Moment M_x	10.2 Nm [90 in-lbs]
Maximum Moment M_y	10.2 Nm [90 in-lbs]
Maximum Moment M_z	10.2 Nm [90 in-lbs]

Capacities are per set of jaws and are not simultaneous

RA-10

Angular Grippers | Dimensions and Technical Specifications

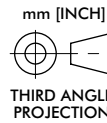
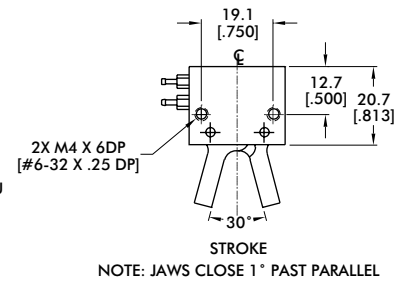
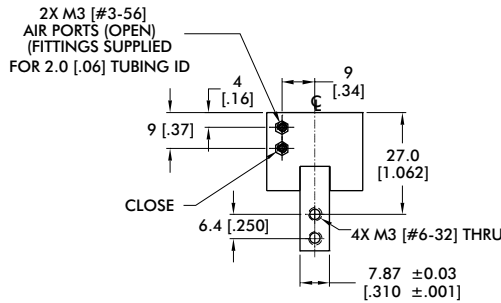
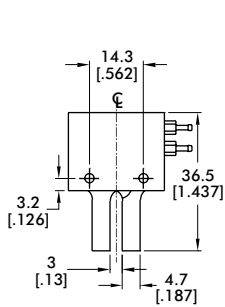
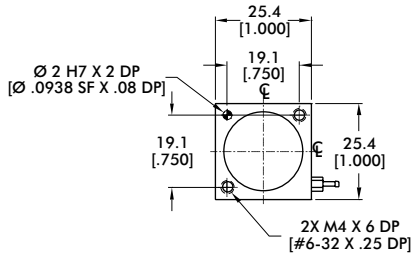

Seal Repair Kits	Order #
Buna-N Seal Repair Kit	SLKT-018
Viton® Seal Repair Kit	SLKT-018V

Loading Information

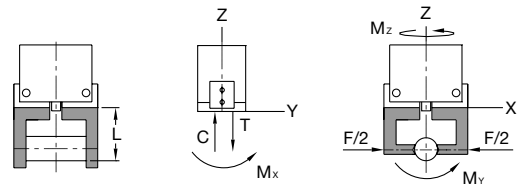
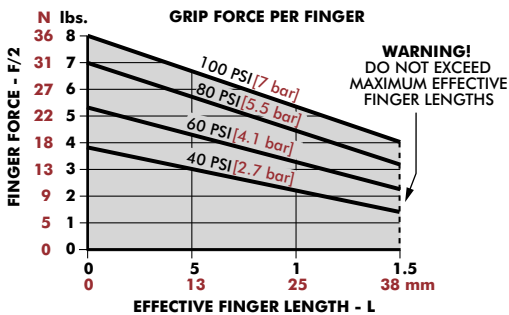

RA-10	Static
Maximum Tensile T	22 N [5 lbs]
Maximum Compressive C	22 N [5 lbs]
Maximum Moment M_x	0.6 Nm [5 in-lbs]
Maximum Moment M_y	0.6 Nm [5 in-lbs]
Maximum Moment M_z	0.6 Nm [5 in-lbs]

*Capacities are per set of jaws and are not simultaneous

RA (TOGGLE LOCK) SERIES

Angular Grippers | Features and Benefits | How To Order

Features:

- Highly reliable rugged general purpose gripper
- Very high grip force to size ratio due to toggle mechanism
- True Failsafe with toggle locking jaws— gripper cannot release part without air
- Optional Viton® seals for high temperatures -30°C to +150°C [-20°F to +300°F]
- Optional inductive sensors and flow controls

Applications:

- Applications requiring internal/external gripping with toggle locking
- Internal gripping Applications without locking
- Industrial assembly machines
- OEM pick and place machines



(USB key shown for scale)

How To Order

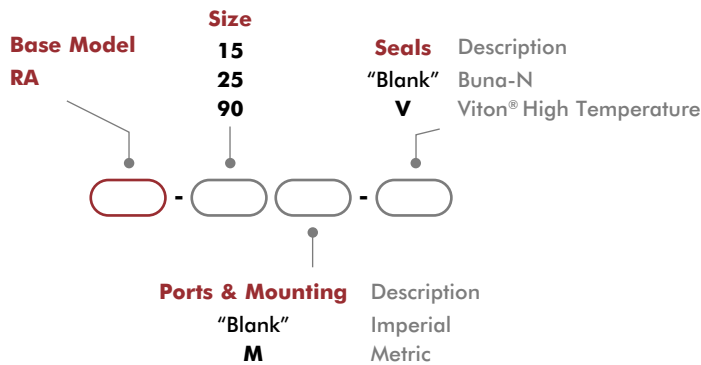

Accessories

Sensor Accessories	Model Numbers	Part Number	Qty/Unit
Sensor Mounting Kit, Mounts 2 Inductive Sensors (Imperial/Metric)	See Datasheet		1
NPN Inductive Sensor with Quick Disconnect*	15, 90	OISN-019	1-2
PNP Inductive Sensor with Quick Disconnect*	15, 90	OISP-019	1-2
NPN Inductive Sensor with Quick Disconnect*	25	OISN-014	1-2
PNP Inductive Sensor with Quick Disconnect*	25	OISP-014	1-2
NPN Magneto Resistive Sensor with Quick Disconnect*	90	OHSN-017	1-2
PNP Magneto Resistive Sensor with Quick Disconnect*	90	OHSP-017	1-2
NPN Magneto Resistive Sensor 90° with Quick Disconnect*	90	OHSN-011	1-2
PNP Magneto Resistive Sensor 90° with Quick Disconnect*	90	OHSP-011	1-2
Quick Disconnect 2 Meter Cable Length*	All Models	CABL-010	1-2
Quick Disconnect 5 Meter Cable Length*	All Models	CABL-013	1-2
Pneumatic Accessories	Model Numbers	Part Number	Qty/Unit
#10-32 to 1/4" OD Tube Flow Controls	90	VLVF-007	2
M5 to 6mm OD Tube Flow Controls	90	VLVF-008	2

* Sensor and cable sold separately.

RA (TOGGLE LOCK) SERIES

Angular Grippers | Technical Specifications

Specifications	Units	15	25	90
Total Rated Grip Force F @ 100 psi [7 bar]	N [lbs]	311 [70]	1112 [250]	356 [80]
Total Stroke		6° per finger (12° total)		90° per finger (180° total)
Stroke Adjustment		--		45° per finger (90° total)
Weight	kg [lbs]	0.14 [0.31]	0.48 [1.06]	0.20 [0.438]
Pressure Range	bar [psi]	3-7 [40-100]		
Ingress Protection Class (IP)		IP43		
Displacement	cm ³ [in ³]	1.8 [0.110]	0.8 [0.046]	7.5 [0.460]
Temperature Range (Buna-N seals)	°C [°F]	-35°~80° [-30°~180°]		
Temperature Range (Viton® seals)	°C [°F]	-30°~150° [-20°~300°]		
Actuation	sec	0.10	0.12	0.16
Accuracy	mm [in]	±0.08 [±0.003]		
Repeatability	mm [in]	±0.03 [±0.0001]		
Valve to Required Actuate Double Acting		4-way, 2-position		

RA-15

Angular Grippers | Dimensions and Technical Specifications

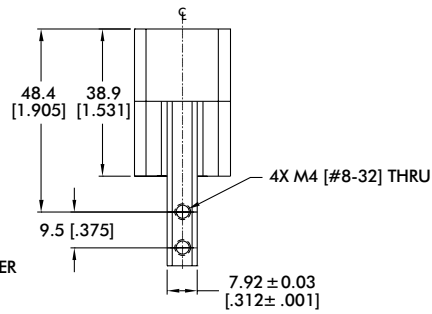
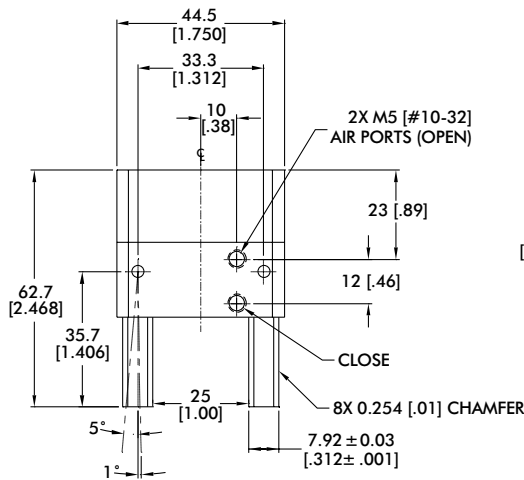
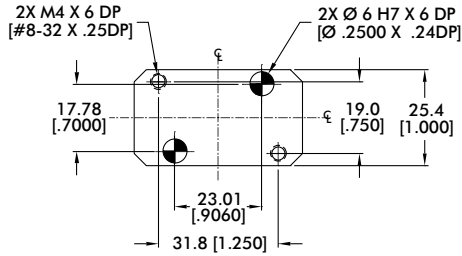

JAW SHOWN PARALLEL
JAW WILL CLOSE 1° PAST PARALLEL

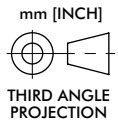

Sensor Accessories	Order #
Inductive Sensor Mounting Kit (mounts 2 sensors)	OSMK-018
Seal Repair Kits	Order #
Buna-N Seal Repair Kit	SLKT-019
Viton® Seal Repair Kit	SLKT-019V

Loading Information

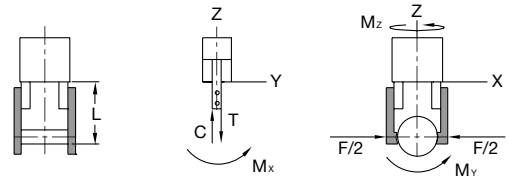
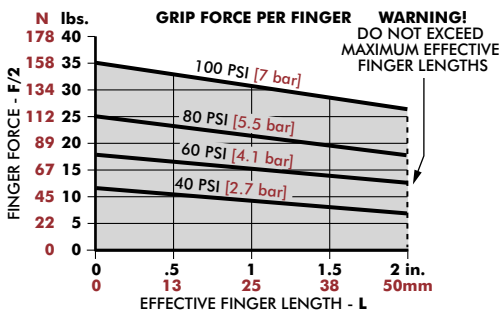

RA-15	Static
Maximum Tensile T	222 N [50 lbs]
Maximum Compressive C	222 N [50 lbs]
Maximum Moment M_x	6.8 Nm [60 in-lbs]
Maximum Moment M_y	13.6 Nm [120 in-lbs]
Maximum Moment M_z	6.8 Nm [60 in-lbs]

*Capacities are per set of jaws and are not simultaneous

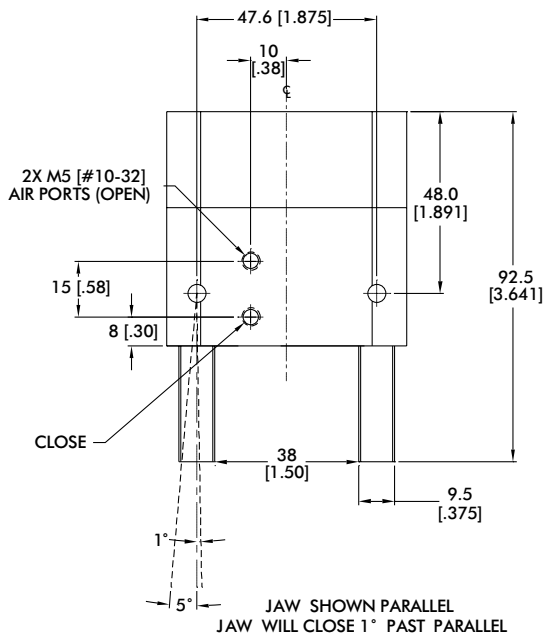
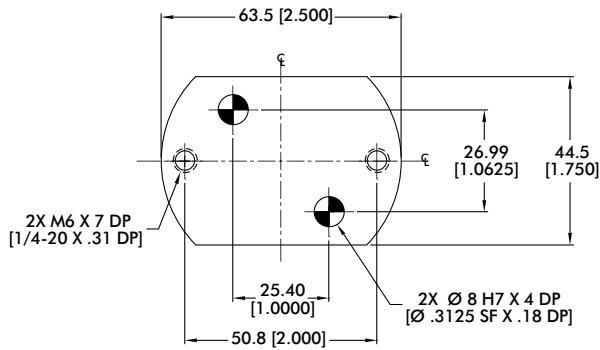

mm [INCH]

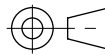

THIRD ANGLE PROJECTION

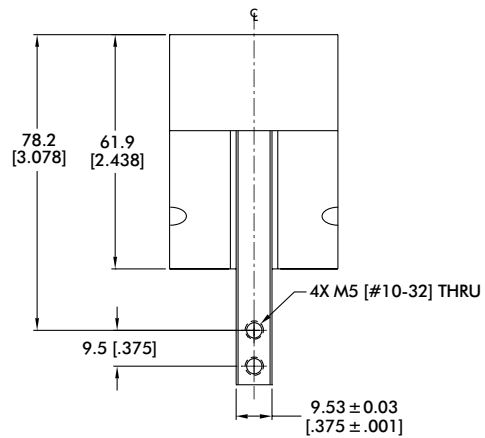

Sensor Accessories	Order #
Inductive Sensor Mounting Kit (mounts 2 sensors)	OSMK-019
Seal Repair Kits	Order #
Buna-N Seal Repair Kit	SLKT-020
Viton® Seal Repair Kit	SLKT-020V

Loading Information

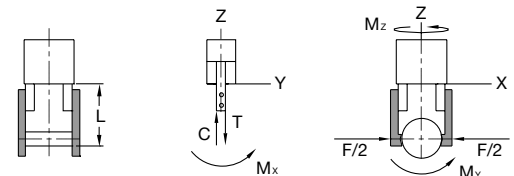
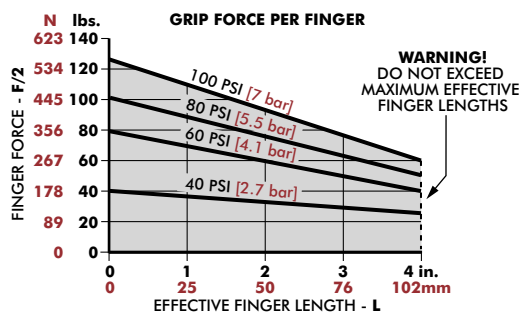

RA-25	Static
Maximum Tensile T	667 N [150 lbs]
Maximum Compressive C	667 N [150 lbs]
Maximum Moment M_x	22.6 Nm [200 in-lbs]
Maximum Moment M_y	33.9 Nm [300 in-lbs]
Maximum Moment M_z	22.6 Nm [200 in-lbs]

*Capacities are per set of jaws and are not simultaneous

RA-90

Angular Grippers | Dimensions and Technical Specifications

DO NOT OPERATE WITHOUT FLOW CONTROLS

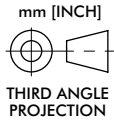
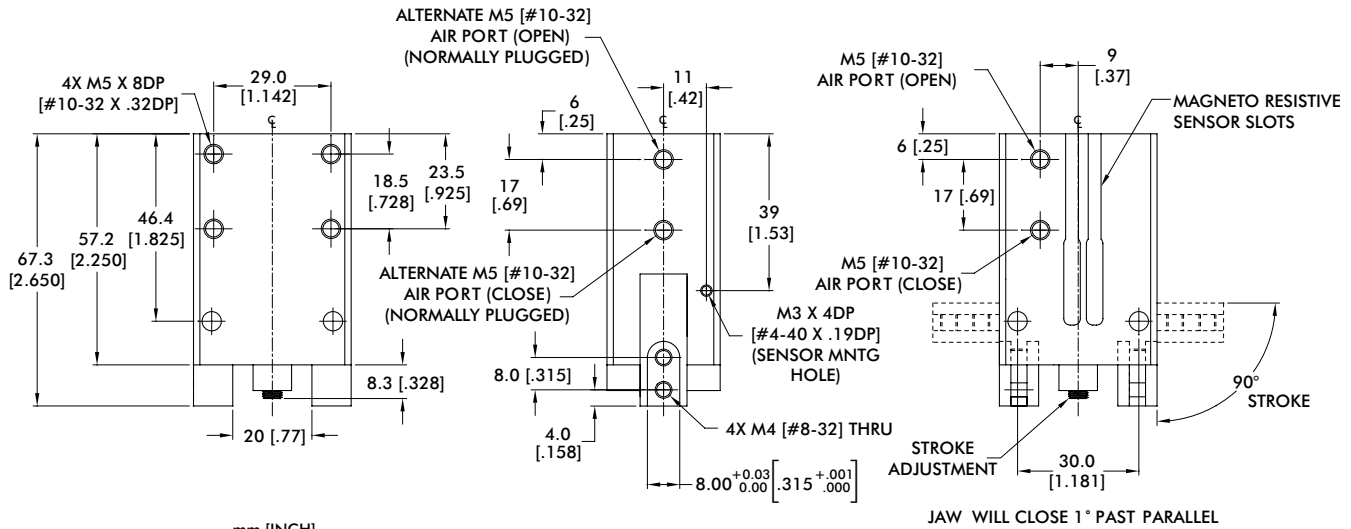
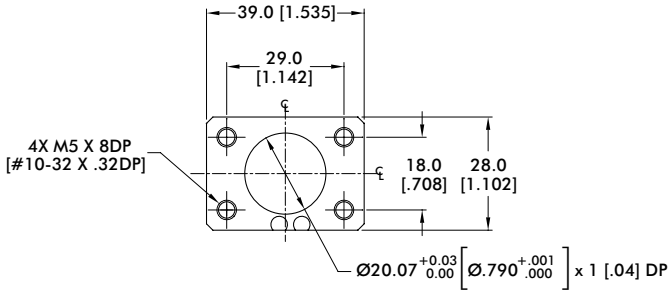

Sensor Accessories		Order #
Inductive Sensor Mounting Kit (mounts 2 sensors)		OSMK-003
Seal Repair Kits		Order #
Buna-N Seal Repair Kit		SLKT-024
Viton® Seal Repair Kit		SLKT-024V

Loading Information

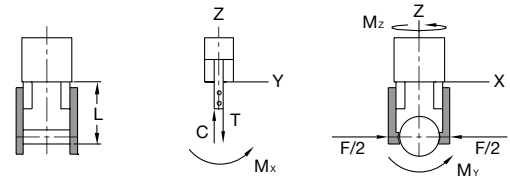
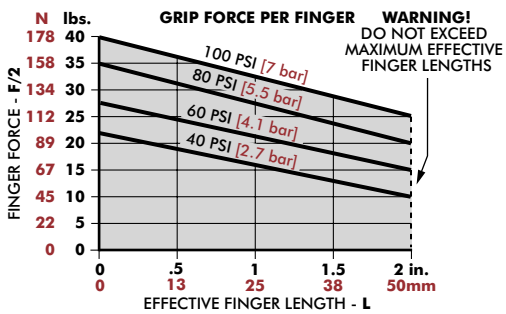

RA-90	Static
Maximum Tensile T	222 N [50 lbs]
Maximum Compressive C	222 N [50 lbs]
Maximum Moment M_x	6.8 Nm [60 in-lbs]
Maximum Moment M_y	13.6 Nm [120 in-lbs]
Maximum Moment M_z	6.8 Nm [60 in-lbs]

¹Capacities are per set of jaws and are not simultaneous

ANGULAR GRIPPERS

Notes

RUA SERIES

Angular Grippers | Features and Benefits | How To Order

Features:

- Robust, shielded, high force gripper
- Optional springs for part retention in case of air loss or increased grip-force
- Side or top manifold air ports
- Optional Viton® seals for high temperatures -30°C to +150°C [-20°F to +300°F]
- Boot options available for weld splatter applications

Applications:

- Welding and sandblasting applications
- Paintbooth applications
- Heavy part gripping solutions

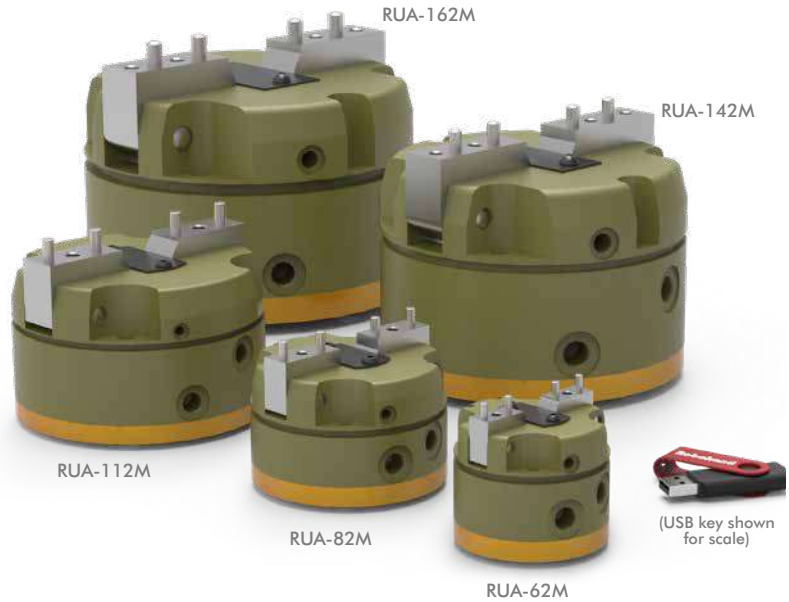

How To Order

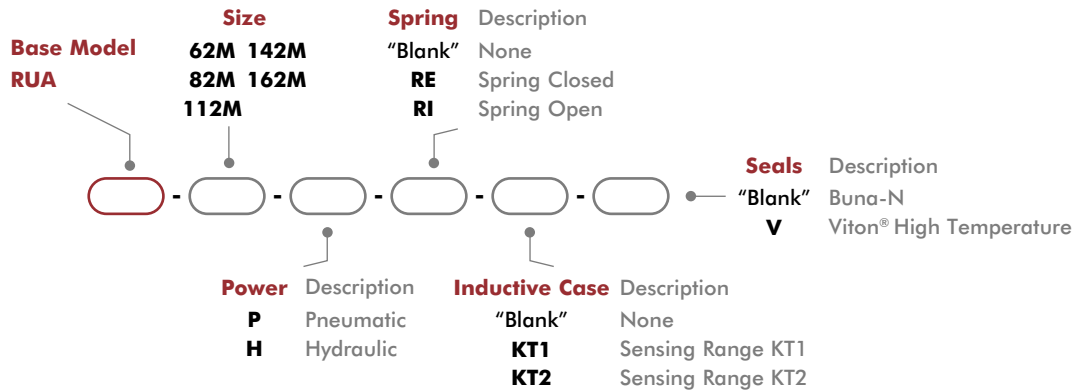

Accessories

Sensor Accessories	Model Numbers	Part Number	Qty/Unit
NPN Magneto Resistive Sensor with Quick Disconnect* **	62M, 82M, 112M	OHSN-017	1-2
PNP Magneto Resistive Sensor with Quick Disconnect* **	62M, 82M, 112M	OHSP-017	1-2
NPN Magneto Resistive Sensor 90° with Quick Disconnect* **	62M, 82M, 112M	OHSN-011	1-2
PNP Magneto Resistive Sensor 90° with Quick Disconnect* **	62M, 82M, 112M	OHSP-011	1-2
Replacement PNP Double Inductive Sensor* †	All Models	KT15	1
Quick Disconnect 2 Meter Cable Length*	62M, 82M, 112M	CABL-010	1-2
Quick Disconnect 5 Meter Cable Length*	62M, 82M, 112M	CABL-013	1-2
Quick Disconnect 2 Meter Cable Length (for KT Inductive Sensor)*	All Models	CABL-014	1-2

*Sensor and cable sold separately. **Piston magnet standard. †Requires KT1 or KT2 sensor option.

Specifications	Units	62M	82M	112M
Total Rated Grip Force L=25mm [1 in.] @ 0°				
@ 7 bar [100 psi], w/spring	N [lbs]	384 [86]	1228 [276]	2150 [483]
@ 7 bar [100 psi], w/o spring	N [lbs]	313 [70]	922 [207]	1600 [360]
Total Stroke		16.8° per finger (33.6° total)	15.9° per finger (31.8° total)	19.1° per finger (38.2° total)
Weight	kg [lbs]	0.39 [0.86]	0.70 [1.55]	1.70 [3.75]
Pressure Range without springs	bar [psi]	2-7 [30-100]		
Pressure Range with springs -RE, -RI	bar [psi]	3-7 [45-100]		
Ingress Protection Class (IP)		IP54		
Displacement	cm ³ [in ³]	12 [0.73]	35 [2.14]	85 [5.19]
Temperature Range (Buna-N seals)	°C [°F]	-35°~80° [-30°~180°]		
Temperature Range (Viton® seals)	°C [°F]	-30°~150° [-20°~300°]		
Actuation	sec	0.18	0.10	0.35
Accuracy	mm [in]	±0.05 [±0.002]		±0.08 [±0.003]
Repeatability	mm [in]	±0.02 [±0.0008]		±0.03 [±0.0008]
Valve to Required Actuate Single Acting		3-way, 2-position		
Valve to Required Actuate Double Acting		4-way, 2-position		

Specifications	Units	142M	162M
Total Rated Grip Force L=25mm [1 in.] @ 0°			
@ 7 bar [100 psi], w/spring	N [lbs]	5775 [1298]	5490 [1234]
@ 7 bar [100 psi], w/o spring	N [lbs]	3941 [886]	3790 [853]
Total Stroke		17.6° per finger (35.2° total)	17.2° per finger (34.4° total)
Weight	kg [lbs]	4.1 [9.05]	6.7 [14.8]
Pressure Range without springs	bar [psi]	2-7 [30-100]	
Pressure Range with springs -RE, -RI	bar [psi]	4-7 [60-100]	
Ingress Protection Class (IP)		IP54	
Displacement	cm ³ [in ³]	215 [13.2]	322 [19.7]
Temperature Range (Buna-N seals)		-35°~80° [-30°~180°]	
Temperature Range (Viton® seals standard)	°C [°F]	-30°~150° [-20°~300°]	
Actuation	sec	0.60	0.80
Accuracy	mm [in]	±0.8 [±0.003]	
Repeatability	mm [in]	±0.03 [±0.0008]	
Valve to Required Actuate Single Acting		3-way, 2-position	
Valve to Required Actuate Double Acting		4-way, 2-position	

RUA-62M

Angular Grippers | Dimensions and Technical Specifications

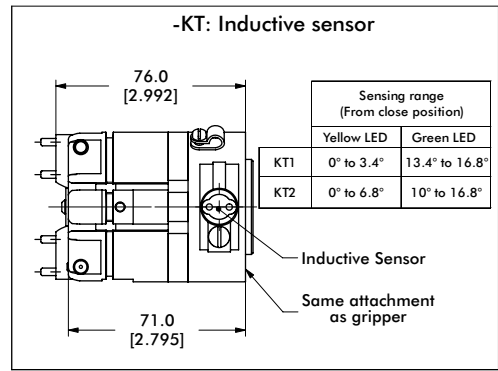
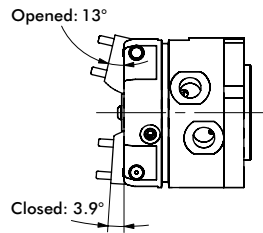
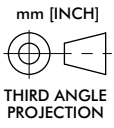
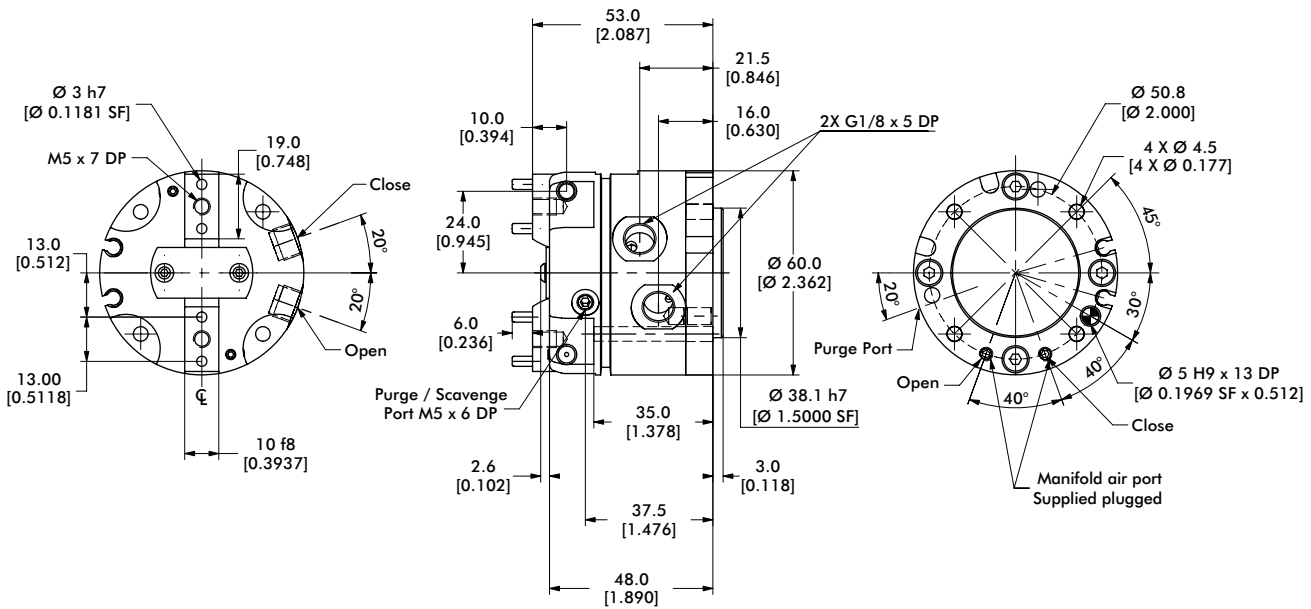

Protective Boots		Order #
PVC Sealed Boot Kit (2 interfaces, 1 collar, 1 boot)		SLKT-367
Kevlar Sealed Boot Kit (2 interfaces, 1 collar, 1 boot)		SLKT-368

Seal Repair Kits		Order #
Seal Repair Kit Standard (Buna-N)		SLKT-156
Seal Repair Kit (Viton®)		SLKT-156V
Seal Repair Kit (Hydraulic)		SLKT-330

Loading Information

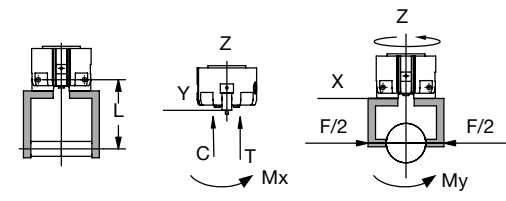
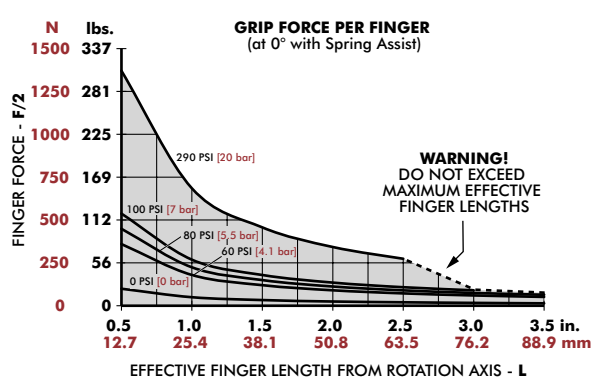

RUA-62M	Static
Maximum Tensile T	236 N [53 lbs]
Maximum Compressive C	236 N [53 lbs]
Maximum Moment M_x	12.5 Nm [111 in-lbs]
Maximum Moment M_y	34.5 Nm [305 in-lbs]
Maximum Moment M_z	12.5 Nm [111 in-lbs]

^tCapacities are per set of jaws and are not simultaneous

Angular Grippers | Dimensions and Technical Specifications

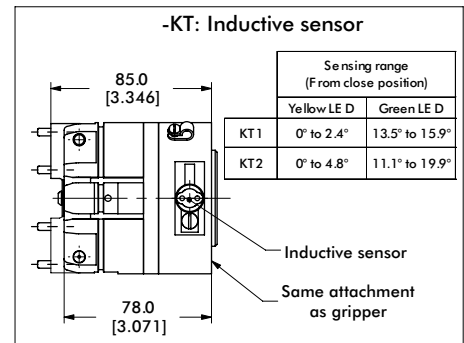
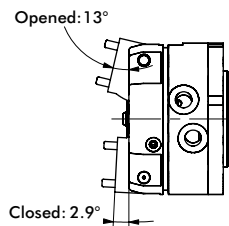
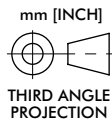
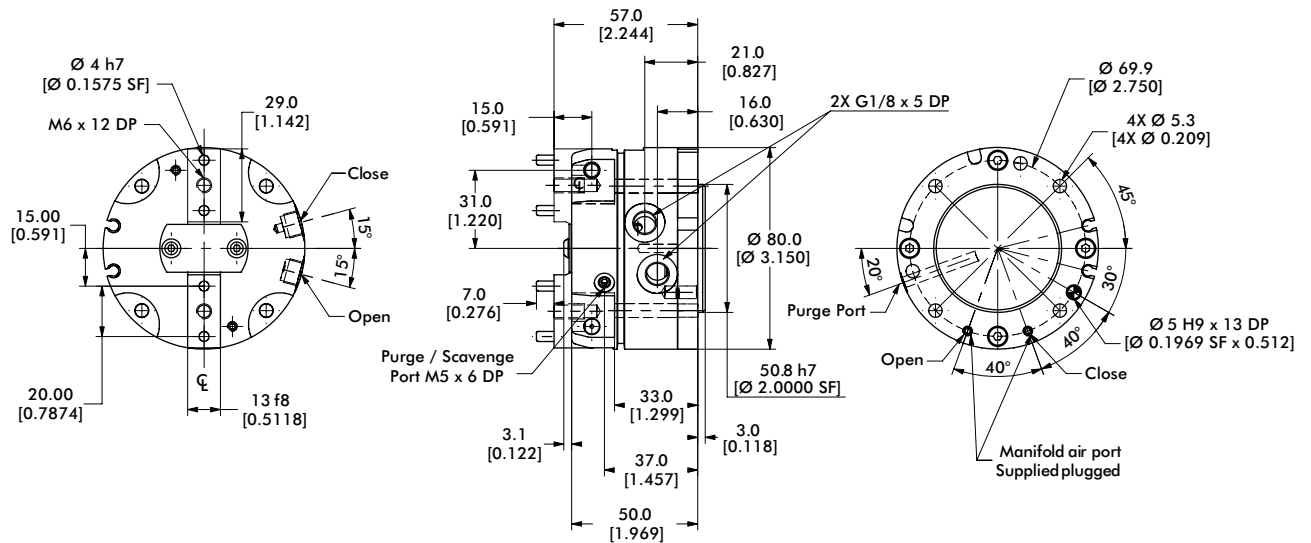

Protective Boots	Order #
PVC Sealed Boot Kit (2 interfaces, 1 collar, 1 boot)	SLKT-370
Kevlar Sealed Boot Kit (2 interfaces, 1 collar, 1 boot)	SLKT-371

Seal Repair Kits	Order #
Seal Repair Kit Standard (Buna-N)	SLKT-157
Seal Repair Kit (Viton®)	SLKT-157V
Seal Repair Kit (Hydraulic)	SLKT-331

Loading Information

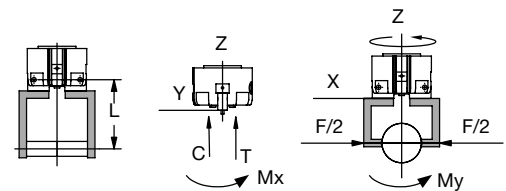
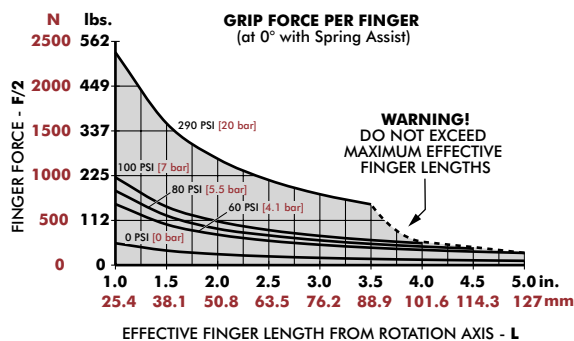

RUA-82M	Static
Maximum Tensile T	290 N [65 lbs]
Maximum Compressive C	290 N [65 lbs]
Maximum Moment M_x	19 Nm [168 in-lbs]
Maximum Moment M_y	121 Nm [1071 in-lbs]
Maximum Moment M_z	19 Nm [168 in-lbs]

[†]Capacities are per set of jaws and are not simultaneous

RUA-112M

Angular Grippers | Dimensions and Technical Specifications

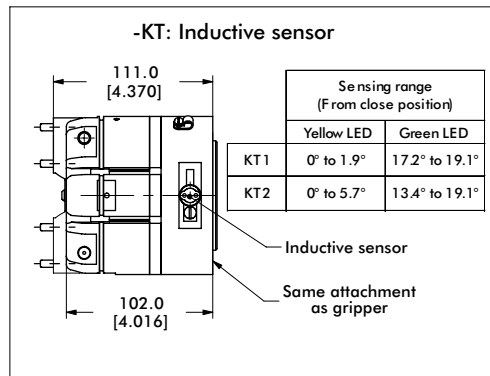
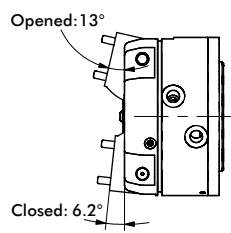
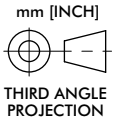
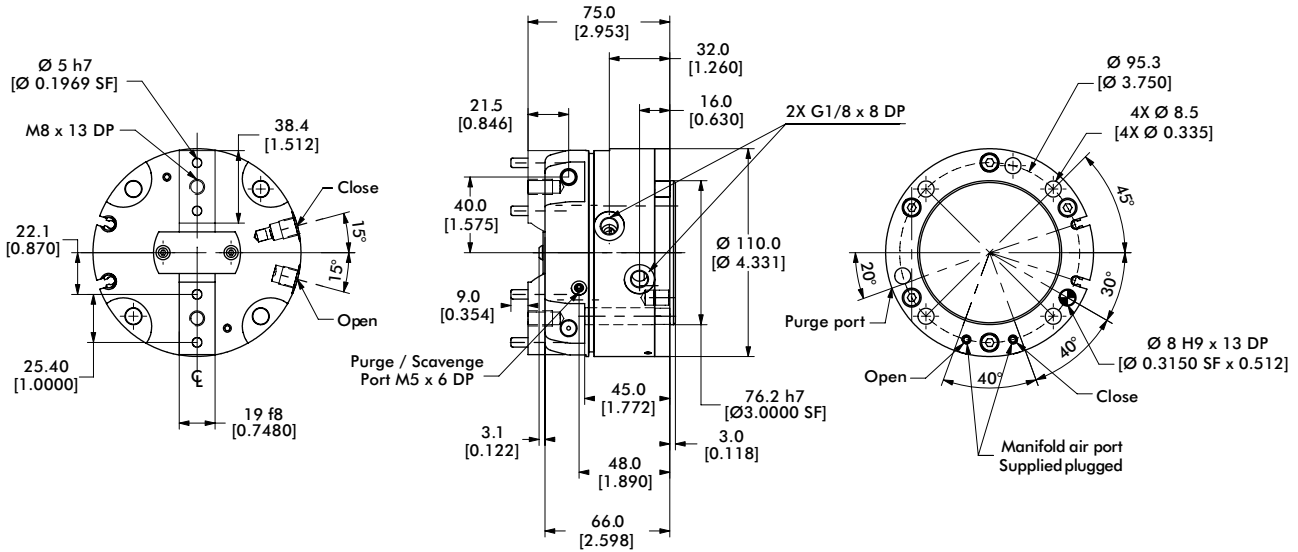

Protective Boots		Order #
PVC Sealed Boot Kit (2 interfaces, 1 collar, 1 boot)		SLKT-373

Seal Repair Kits		Order #
Seal Repair Kit Standard (Buna-N)		SLKT-158
Seal Repair Kit (Viton®)		SLKT-158V
Seal Repair Kit (Hydraulic)		SLKT-332

Loading Information

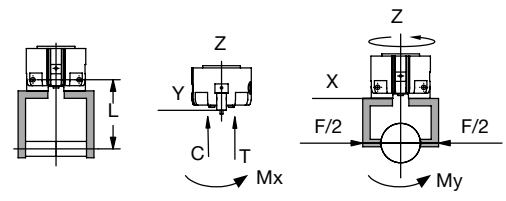
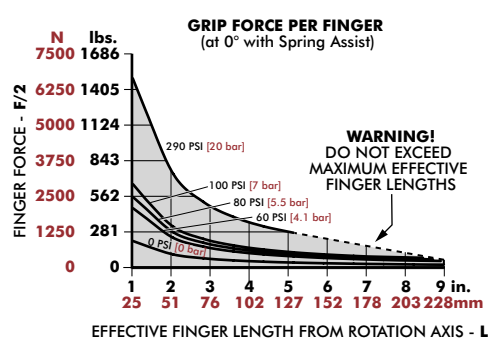

RUA-112M	Static
Maximum Tensile T	290 N [65 lbs]
Maximum Compressive C	290 N [65 lbs]
Maximum Moment M_x	19 Nm [168 in-lbs]
Maximum Moment M_y	121 Nm [1071 in-lbs]
Maximum Moment M_z	19 Nm [168 in-lbs]

*Capacities are per set of jaws and are not simultaneous

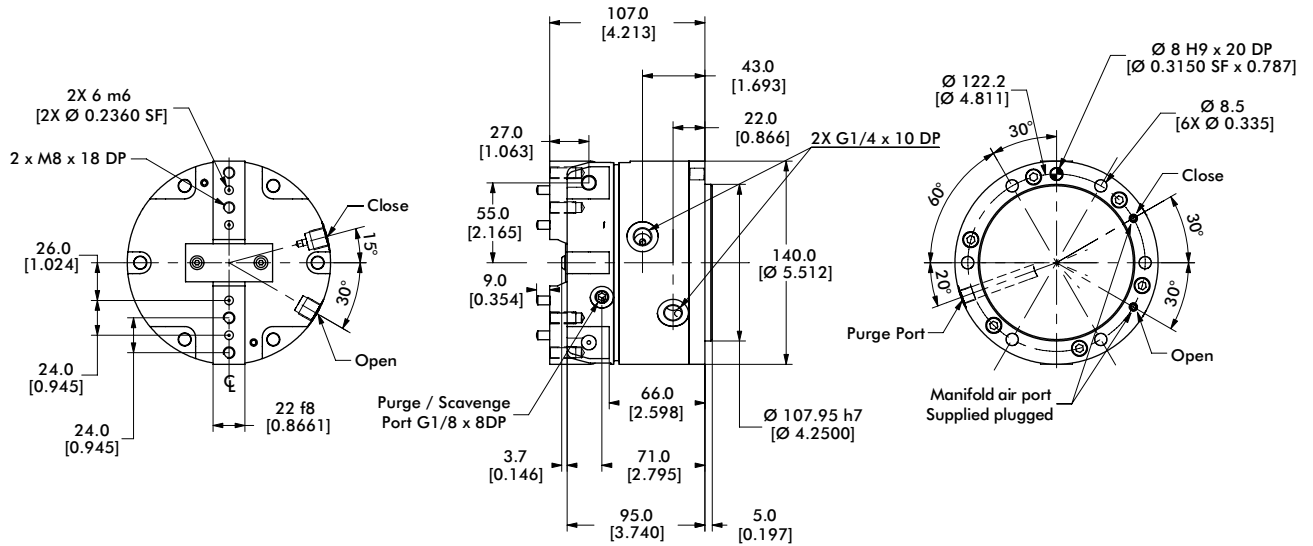

mm [INCH]
THIRD ANGLE PROJECTION

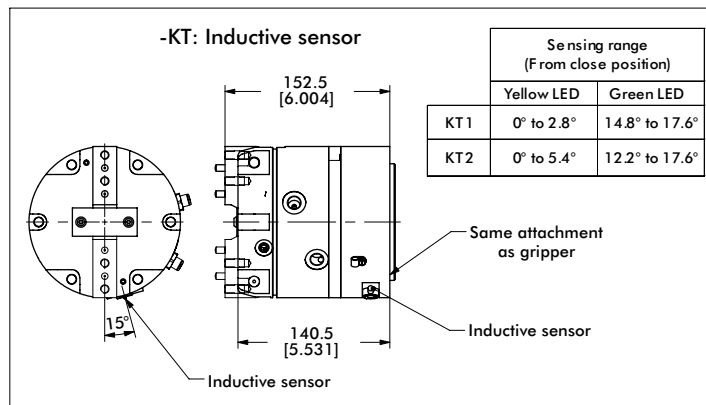
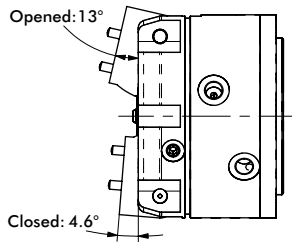

Protective Boots	Order #
PVC Sealed Boot Kit (2 interfaces, 1 collar, 1 boot)	SLKT-376

Seal Repair Kits	Order #
Seal Repair Kit Standard (Buna-N)	SLKT-333
Seal Repair Kit (Viton®)	SLKT-333V
Seal Repair Kit (Hydraulic)	SLKT-334

Loading Information

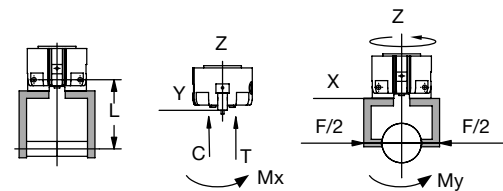
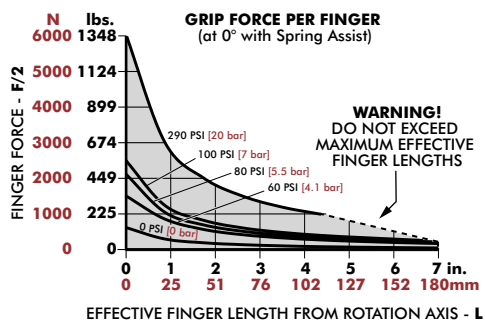

RUA-142M	Static
Maximum Tensile T	630 N [142 lbs]
Maximum Compressive C	630 N [142 lbs]
Maximum Moment M_x	52 Nm [460 in-lbs]
Maximum Moment M_y	696 Nm [6160 in-lbs]
Maximum Moment M_z	52 Nm [460 in-lbs]

*Capacities are per set of jaws and are not simultaneous

RUA-162M

Angular Grippers | Dimensions and Technical Specifications

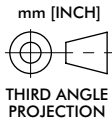
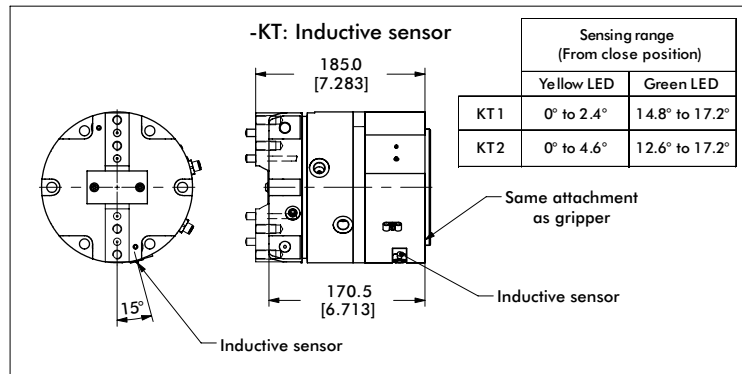
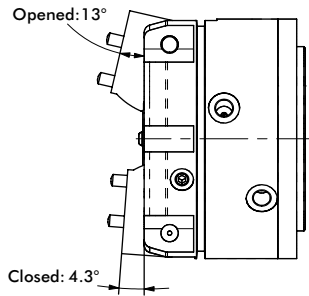
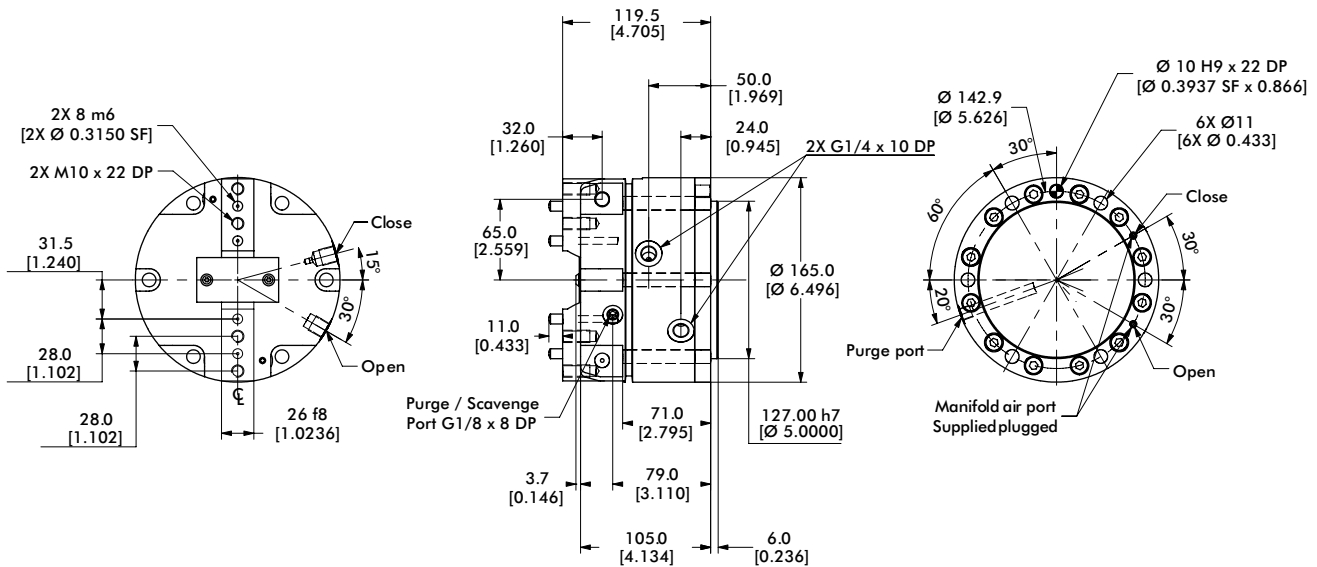

Protective Boots	Order #
PVC Sealed Boot Kit (2 interfaces, 1 collar, 1 boot)	SLKT-379

Seal Repair Kits	Order #
Seal Repair Kit Standard (Buna-N)	SLKT-335
Seal Repair Kit (Viton®)	SLKT-335V
Seal Repair Kit (Hydraulic)	SLKT-336

Loading Information

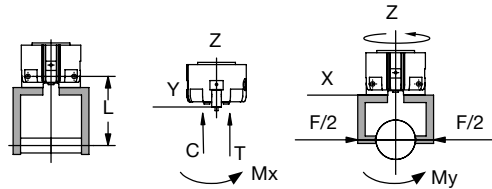
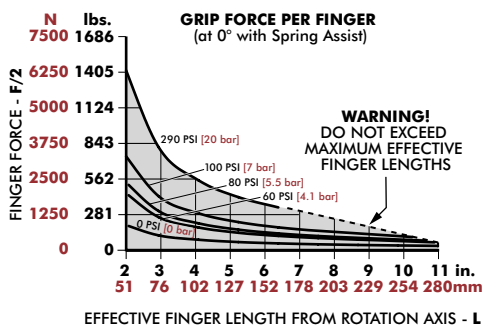

RUA-162M	Static
Maximum Tensile T	840 N [189 lbs]
Maximum Compressive C	840 N [189 lbs]
Maximum Moment M_x	75 Nm [664 in-lbs]
Maximum Moment M_y	1050 Nm [9293 in-lbs]
Maximum Moment M_z	75 Nm [664 in-lbs]

*Capacities are per set of jaws and are not simultaneous

FUA SERIES

Angular Food Grippers | Features and Benefits | How To Order

Features:

- Designed for direct product contact in the food zone, according to the food industry standard (EN 1672-2)
- All parts are corrosion resistant, non-toxic, non-contaminating, non-porous, non-absorbent and non-reactive
- Stainless steel design resists chemical cleaning procedures
- Electro-polished exterior with no recessed or inaccessible zones prevents retention of contaminants and simplifies cleaning
- Sealed motion components (IP69K design) for high-pressure and high-temperature daily cleanings
- Any metal/metal contact protected by gasket to obtain a leakproof assembly against bacteria
- Angular gripper design for easier radial sealing of jaws
- Optional safety springs for external gripping, in case of air supply failure, in single acting or spring assist mode
- No external fasteners to avoid any foreign matter in food
- Contains special lubricants suitable for food industry
- Long maintenance-free service life



Applications:

- Food zone and splash zone handling of product
- Non-food zone applications
- Other applications requiring a sealed and corrosion resistant gripper

How To Order

Base Model
FUA-50M
FUA-63M

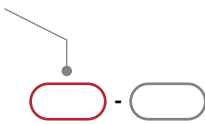

Spring	Description
"Blank"	None
C	Spring Closed

Angular Food Grippers | Dimensions and Technical Specifications

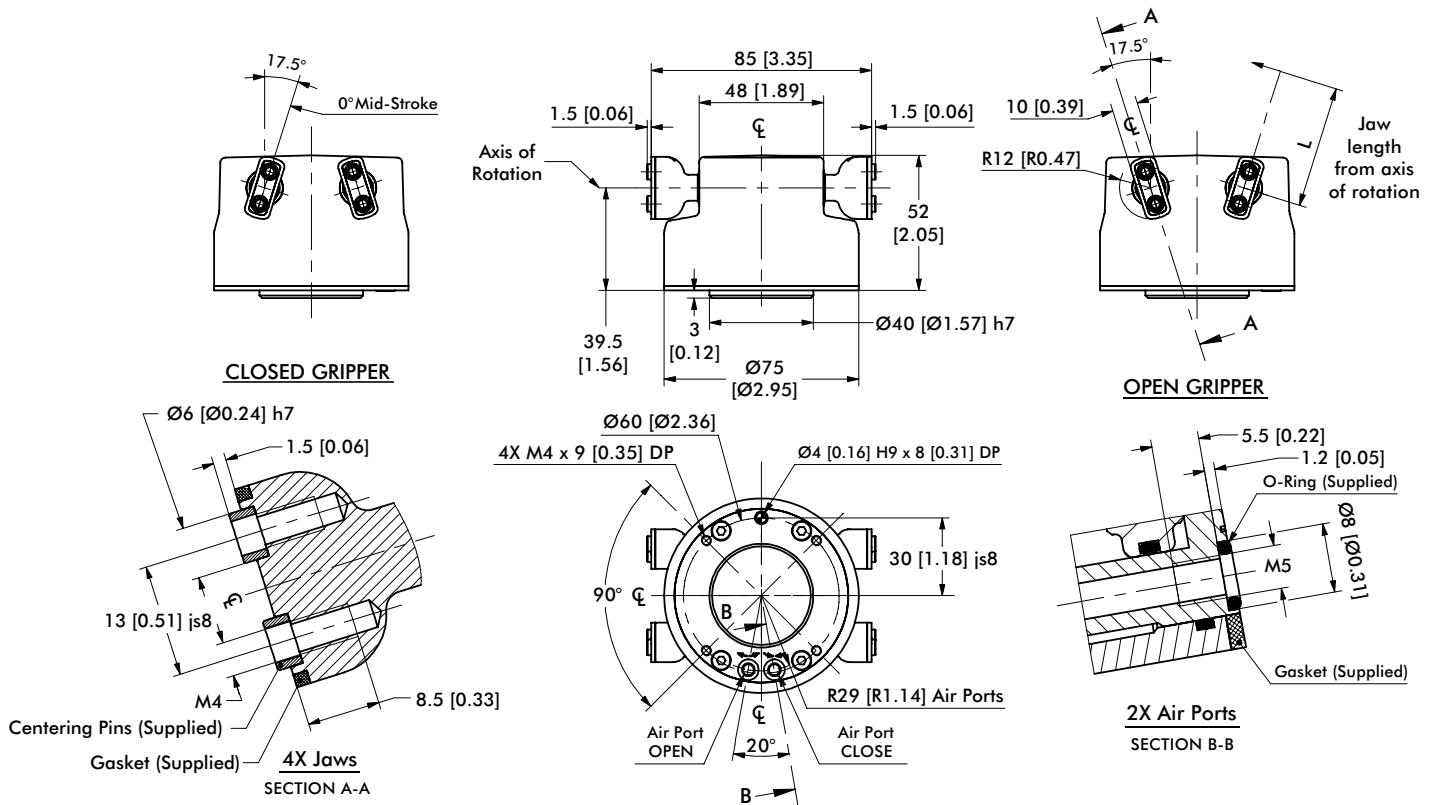

Specifications	Units	FUA-50M
Torque, Jaws @ 6 bar [87 psi]		
@ 35° w/o spring (closing)	Nm [in-lbs]	13 [115]
@ 35° w/spring (closing)	Nm [in-lbs]	16 [142]
@ 0° w/o spring (opening)	Nm [in-lbs]	14 [124]
Total Stroke		70°
Weight (Stainless Steel)	kg [lbs]	1,06 [2.34]
Pressure Range	bar [psi]	3-7 [44-100]
Ingress Protection Class (IP)		IP69K
Displacement	cm ³ [in ³]	30,2 [1.84]
Temperature Range	°C [°F]	-15°~80° [5°~175°]
Actuation (open/close)	sec	0.07 / 0.07

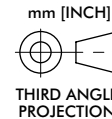

Seal Repair Kits	Order #
Flat Seals Repair Kit (Jaw and Body)	SLKT-424
Complete Seal Repair Kit (includes Flat Seals)	SLKT-425
Rear and Body Seal Repair Kit (Include Air Port O-Rings)	SLKT-428

Loading Information

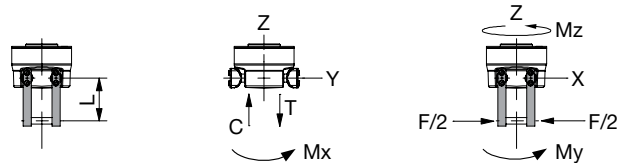
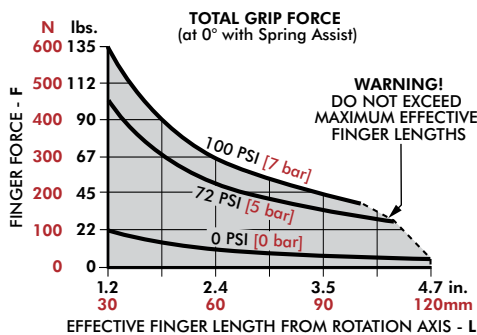

RUA-162M	Static	Dynamic
Maximum Tensile T	305 N [69 lbs]	61 N [14 lbs]
Maximum Compressive C	305 N [69 lbs]	61 N [14 lbs]
Maximum Moment M_x	21 Nm [186 in-lbs]	5,3 Nm [47 lbs]
Maximum Moment M_y	--	--
Maximum Moment M_z	21 Nm [186 in-lbs]	5,3 Nm [47 lbs]

*Capacities are per set of jaws and are not simultaneous

FUA-63M

Angular Food Grippers | Dimensions and Technical Specifications

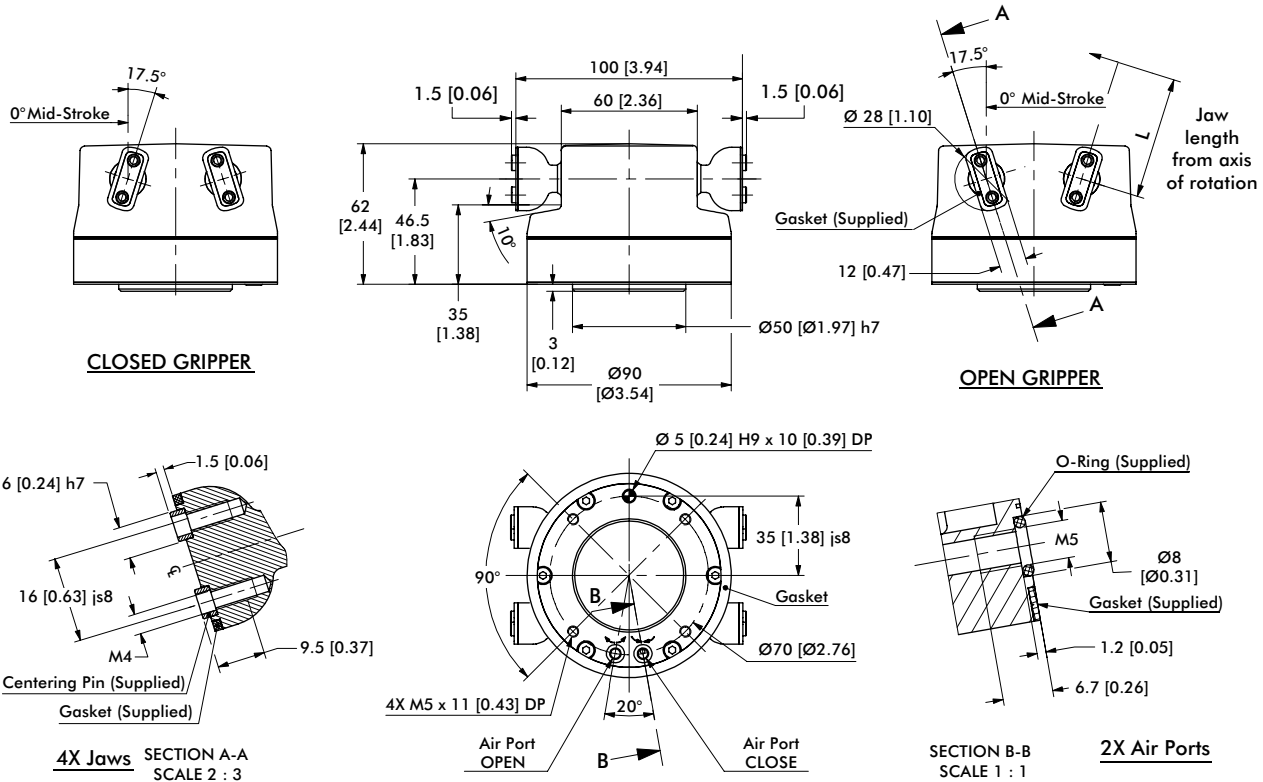

Specifications	Units	FUA-63M
Torque, Jaws @ 6 bar [87 psi]		
@ 35° w/o spring (closing)	Nm [in-lbs]	23 [204]
@ 35° w/spring (closing)	Nm [in-lbs]	29 [257]
@ 0° w/o spring (opening)	Nm [in-lbs]	25 [221]
Total Stroke		70°
Weight (Stainless Steel)	kg [lbs]	1.75 [8.27]
Pressure Range	bar [psi]	3-7 [44-100]
Ingress Protection Class (IP)		IP69K
Displacement	cm ³ [in ³]	53,8 [3.30]
Temperature Range	°C [°F]	-15°~80° [5°~175°]
Actuation (open/close)	sec	0.08 / 0.08

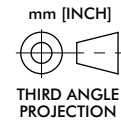

Seal Repair Kits	Order #
Flat Seals Repair Kit (Jaw and Body)	SLKT-426
Complete Seal Repair Kit (includes Flat Seals)	SLKT-427
Rear and Body Seal Repair Kit (Include Air Port O-Rings)	SLKT-429

Loading Information

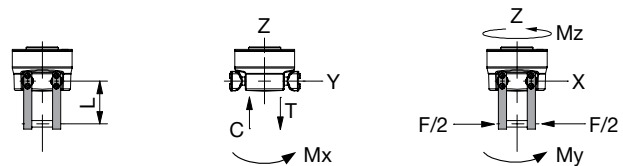
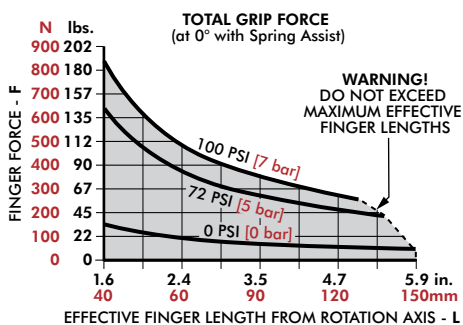

RUA-162M	Static	Dynamic
Maximum Tensile T	360 N [81 lbs]	72 N [16 lbs]
Maximum Compressive C	360 N [81 lbs]	72 N [16 lbs]
Maximum Moment M _x	33 Nm [292 in-lbs]	8,3 Nm [73 in-lbs]
Maximum Moment M _y	--	--
Maximum Moment M _z	33 Nm [292 in-lbs]	8,3 Nm [73 in-lbs]

*Capacities are per set of jaws and are not simultaneous

ROTARY ACTUATORS

Rotary Actuators | Application Examples

DESTACO's RR Series of heavy-duty rotary actuators are compact models that are designed for large capacity, high torque applications in tight spaces – such as industrial and foundry projects. These models feature preloaded bearings for high repeatability rotary actuation, zero backlash with precision slip fit dowel pins, and mount the payload directly to the flange without additional support.

Markets



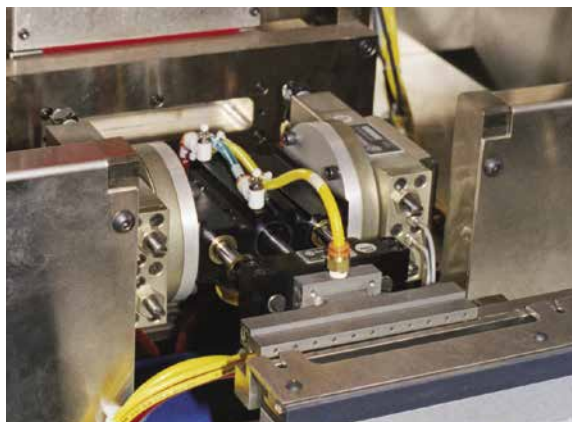
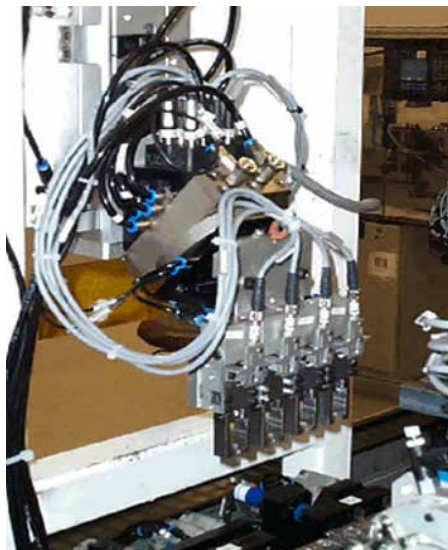
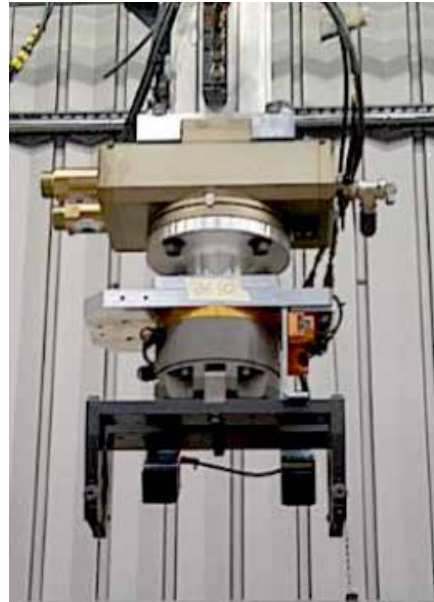
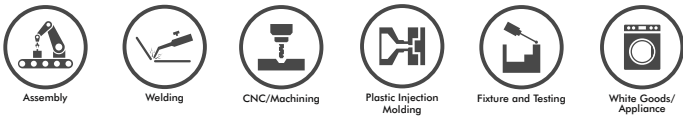

Applications



ROTARY ACTUATORS

Rotary Actuators | Product Overview

Model	Stroke Range	Payload Range	Operating Environment	Special Features	Page GR-ROT#
RR-18 & 28 	0°-180°	0.45-1.3 [1-3]	IP66 with Purge and Seal option. Clean Room Class 100,000, ISO 8	Compact Size. Flange Payload Mount. Full Torque at End of Stroke.	3
RR-36 thru 66 	0°-180°	3.6-34 [8-75]	IP55. Clean Room Class 100,000, ISO 9	Large Payload. Flange Payload Mount. Zero Backlash. Optional 4 port rotary manifold.	7

RR LIGHT-DUTY SERIES

Rotary Actuators | Features and Benefits | How To Order

Features:

- Ultra-thin profile for tight space applications
- Preloaded bearings for high repeatability rotary actuation
- Zero backlash and slip fit dowel pins for precision applications
- Built-in adjustable hard-stops
- Optional manifold eliminates twisted airlines
- CR- Clean room option or for use in harsh environment applications

Applications:

- Precision rotary positioning
- Medical applications
- OEM machines



How To Order

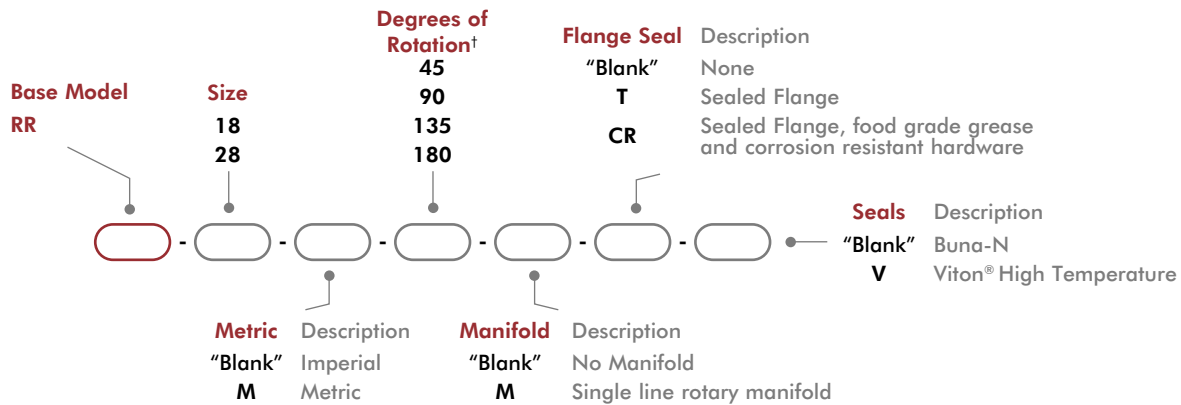

†Consult factory for intermediate degrees of rotation.

Accessories

Sensor Accessories	Model Numbers	Part Number	Qty/Unit
Sensor Mounting Kit (mounts 2 sensors)	All Models	OSMK-024	1
NPN Inductive Sensor with Quick Disconnect*	All Models	OISN-014	1-2
PNP Inductive Sensor with Quick Disconnect*	All Models	OISP-014	1-2
Quick Disconnect 2 Meter Cable Length*	All Models	CABL-010	1-2
Quick Disconnect 5 Meter Cable Length*	All Models	CABL-013	1-2

Pneumatic Accessories	Model Numbers	Part Number	Qty/Unit
M3 Plumbing Fitting Push-In for 3mm OD Tube	All Models	PLFT-021	2
M3 Plumbing Fitting Barb for 2mm ID Tube	All Models	PLFT-022	2
#10-32 Flow Control (Imperial)	All Models	VLVF-007	2
M5 Flow Control	All Models	VLVF-008	2

*Sensor and cable sold separately.

RR LIGHT-DUTY SERIES

Rotary Actuators | Technical Specifications

Specifications	Units	18	28
Maximum Payload	kg [lb]	0.45 [1.0]	1.36 [3.0]
Maximum Payload Inertia	Nm sec ² [in-lbs sec ²]	0.000181 [0.0016]	0.001255 [0.0111]
Maximum Rotation		180°	
Maximum Torque Mid-Stroke @ 100psi/7 bar	Nm [lbs-in]	0.7 [6.5]	2.5 [22]
Maximum Torque End Stroke @ 100psi/7 bar			
Pitch Diameter of Pinion	mm [in]	8.46 [0.333]	12.7 [0.50]
Weight	kg [lb]	0.22 [0.48]	0.65 [1.44]
Pressure Range	bar [psi]	2-7 [30-100]	
Ingress Protection Class (IP)		IP66	
Displacement (180°)	cm ³ [in ³]	3.37 [0.205]	11.4 [0.69]
Temperature Range (Buna-N seals)	°C [°F]	-35°~80° [-30°~180°]	
Temperature Range (Viton® seals)	°C [°F]	-30°~150° [-20°~300°]	
Actuation Time (180° @ 100psi/7 bar)	sec	0.30	0.35
Actuation Time (90° @ 100psi/7 bar)	sec	0.25	0.30
End Stop Repeatability		±0.02°	
End Stop Adjustability		23°	
Over Travel (each end)		4°	8°
Valve required to actuate		4-way, 2-position	

RR-18

Rotary Actuators | Dimensions and Technical Specifications

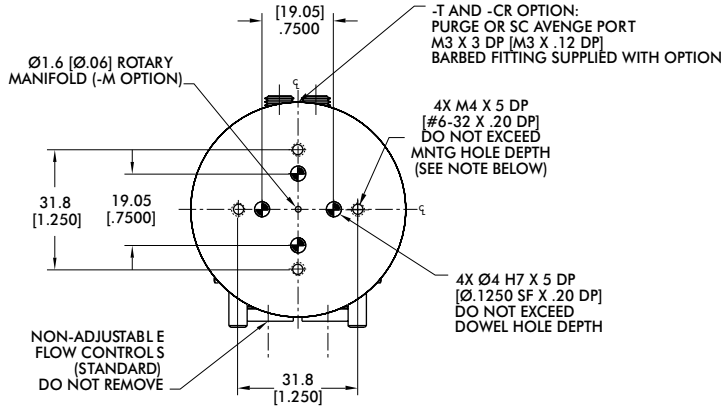

UNIT SHOWN IN 0° POSITION ROTATED FULLY CW

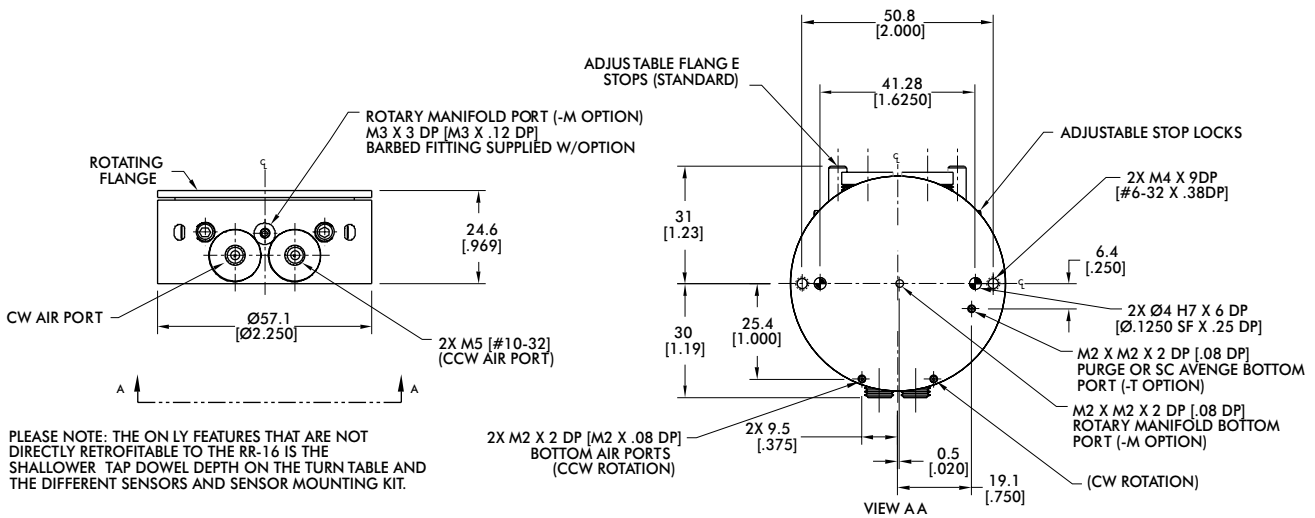
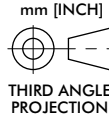

Seal Repair Kits	Order #
Buna-N Seal Repair Kit	SLKT-173
Viton® Seal Repair Kit	SLKT-173V
Viton® Bottom Air Port Manifold Seal Kit	SLKT-174V

Loading Information

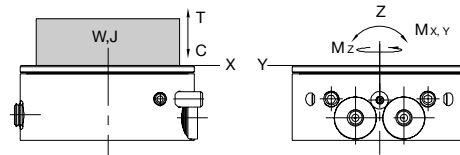

RR-18 Loading Information	Static
Maximum Tensile T	222 N [50 lbs]
Maximum Compressive C	1112 N [250 lbs]
Maximum Moment M_x	11 Nm [100 in-lbs]
Maximum Moment M_y	11 Nm [100 in-lbs]
Maximum Payload W	0.45 kg [1 lbs]
Maximum Inertia J	0.000181 N-m-sec ² [0.0016 in-lbs-sec ²]

Note: Higher payloads and inertia possible with external shocks and stops.

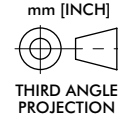
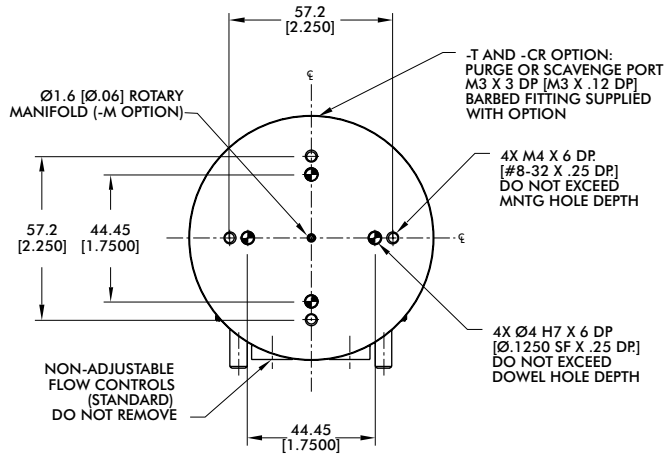

UNIT SHOWN IN 0° POSITION ROTATED FULLY CW

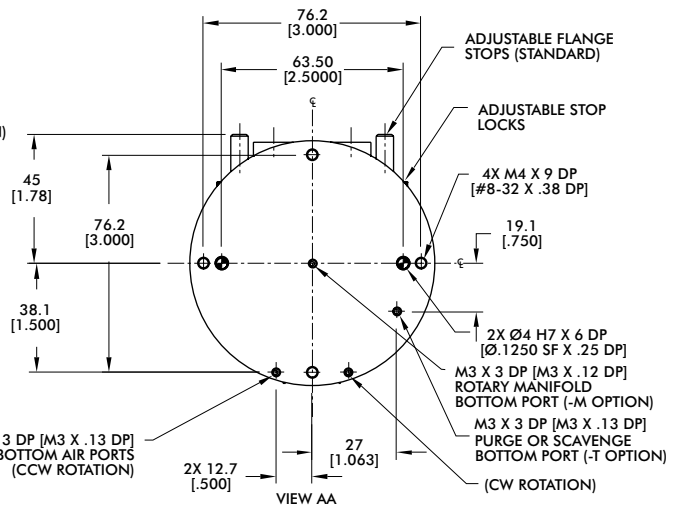
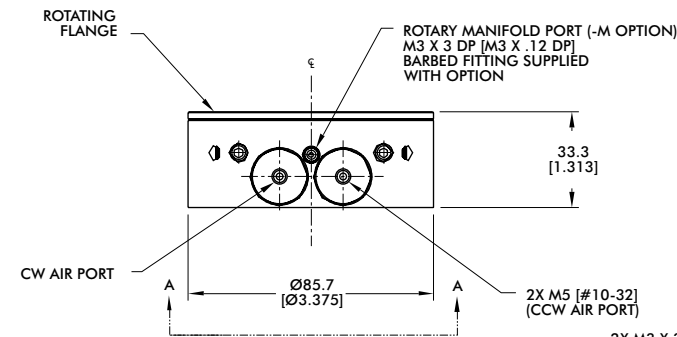

Seal Repair Kits	Order #
Buna-N Seal Repair Kit	SLKT-175
Viton® Seal Repair Kit	SLKT-175V
Viton® Bottom Air Port Manifold Seal Kit	SLKT-176V

Loading Information

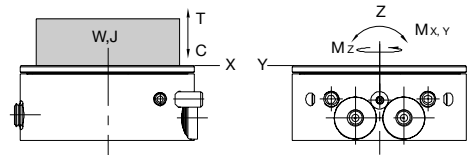

RR-28 Loading Information	Static
Maximum Tensile T	334 N [75 lbs]
Maximum Compressive C	2224 N [500 lbs]
Maximum Moment M _x	28 Nm [250 in-lbs]
Maximum Moment M _y	28 Nm [250 in-lbs]
Maximum Payload W	1.36 kg [3 lbs]
Maximum Inertia J	0.001255 N-m-sec ² [0.0111 in-lbs-sec ²]

Note: Higher payloads and inertia possible with external shocks and stops.

RR MEDIUM-DUTY SERIES

Rotary Actuators | Features and Benefits | How To Order

Features:

- Low profile, high capacity for tight space applications
- Mount payload directly to flange without additional support
- Preloaded bearings for high repeatability rotary actuation
- Zero backlash and slip fit dowel pins for precision applications
- Built-in adjustable hard-stops and shock absorbers
- Adjustable flow controls
- Optional manifold eliminates twisted airlines
- 3 position rotary with option mid-stop

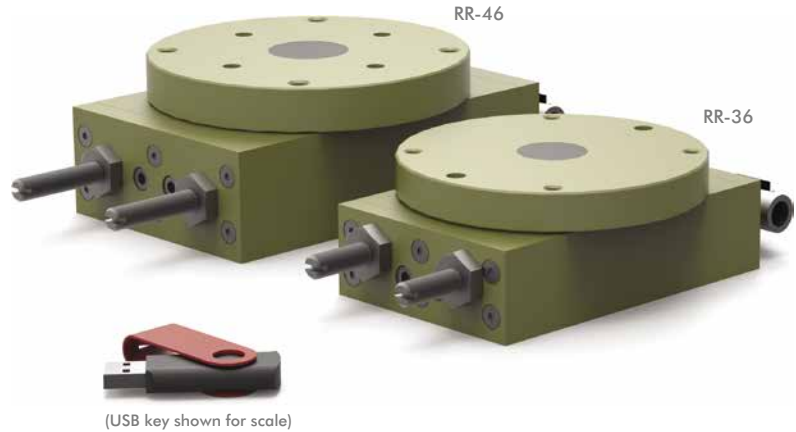

Applications:

- Precision rotary positioning
- Part orientation
- Load and unload

How To Order

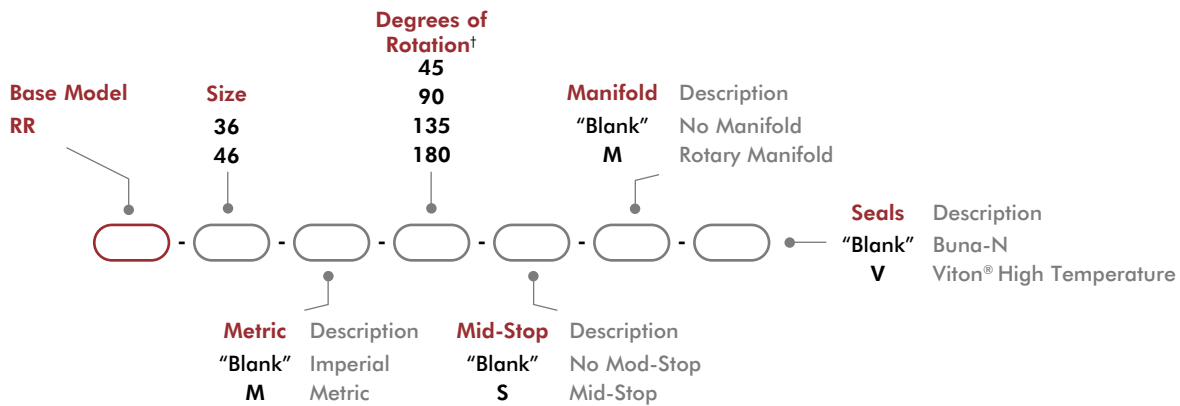

†Consult factory for intermediate degrees of rotation.

Accessories

Sensor Accessories	Model Numbers	Part Number	Qty/Unit
Sensor Mounting Kit (mounts 2 sensors)	All Models	OSMK-024	1
NPN Inductive Sensor with Quick Disconnect*	All Models	OISN-014	1-2
PNP Inductive Sensor with Quick Disconnect*	All Models	OISP-014	1-2
Quick Disconnect 2 Meter Cable Length*	All Models	CABL-010	1-2
Quick Disconnect 5 Meter Cable Length*	All Models	CABL-013	1-2

*Sensor and cable sold separately.

RR MEDIUM-DUTY SERIES

Rotary Actuators | Technical Specifications

Specifications	Units	36	46
Maximum Payload	kg [lb]	3.6 [8.0]	6.8 [15]
Maximum Payload Inertia	Nm sec ² [in-lbs sec ²]	0.00468 [0.0414]	0.01096 [0.0970]
Maximum Rotation		180°	
Maximum Torque Mid-Stroke @ 100psi/7 bar	Nm [lbs-in]	7.4 [65]	14 [122]
Maximum Torque End-Stroke @ 100psi/7 bar	Nm [lbs-in]	3.7 [32]	7 [61]
Weight (base unit)	kg [lb]	1.3 [2.9]	2.3 [5]
Weight Adder for Mid-Position Stop	kg [lb]	0.18 [0.4]	0.19 [0.42]
Weight Adder for Rotary Manifold	kg [lb]	0.04 [0.1]	0.17 [0.38]
Pressure Range	bar [psi]	3-7 [40-100]	
Ingress Protection Class (IP)		IP55	
Displacement (180°)	cm ³ [in ³]	33.6 [2.05]	63.18 [3.855]
Displacement of Mid-Position Stop	cm ³ [in ³]	19.66 [1.200]	35.95 [2.194]
Temperature Range (Buna-N seals)		-0°~66° [32°~150°]	
Temperature Range (Viton® seals)	°C [°F]		
Actuation Time (180° @ 100psi/7 bar)	sec	0.35	0.41
Actuation Time (90° @ 100psi/7 bar)	sec	0.2	0.36
End-Stop Repeatability		±0.02°	
Mid-Stop Repeatability		±0.5°	
End-Stop Adjustability		60°	
Over Travel (each end)		4°	
Valve required to actuate		4-way, 2-position	
Valve required to actuate Mid-Stop		3-way, 2-position	

RR-36

Rotary Actuators | Dimensions and Technical Specifications

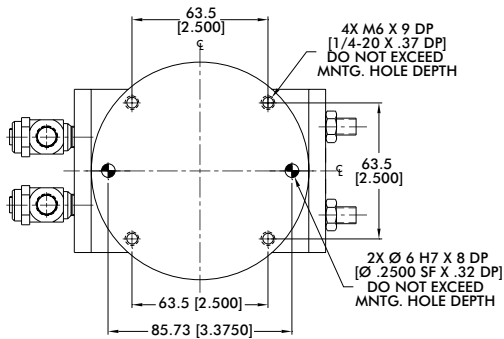

UNIT SHOWN IN 0° POSITION ROTATED FULLY CW

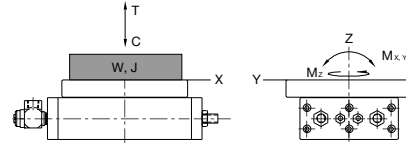

RR-36 Loading information	Static
Maximum Tensile T	2445 N [100 lbs]
Maximum Compressive C	2224 N [500 lbs]
Maximum Moment M _x	34 Nm [300 in-lbs]
Maximum Moment M _y	34 Nm [300 in-lbs]
Maximum Payload W	3.64 kg [8 lbs]
Maximum Inertia J	0.00468 N-m-sec ² [0.0414 in-lbs-sec ²]

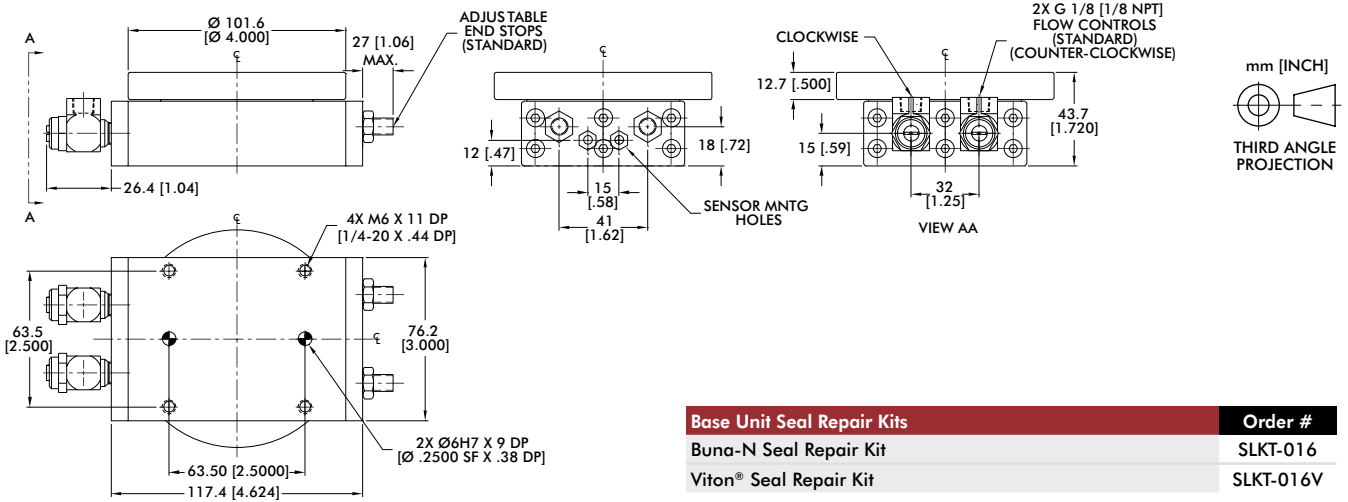

Base Unit Seal Repair Kits	Order #
Buna-N Seal Repair Kit	SLKT-016
Viton® Seal Repair Kit	SLKT-016V

Options Dimensions

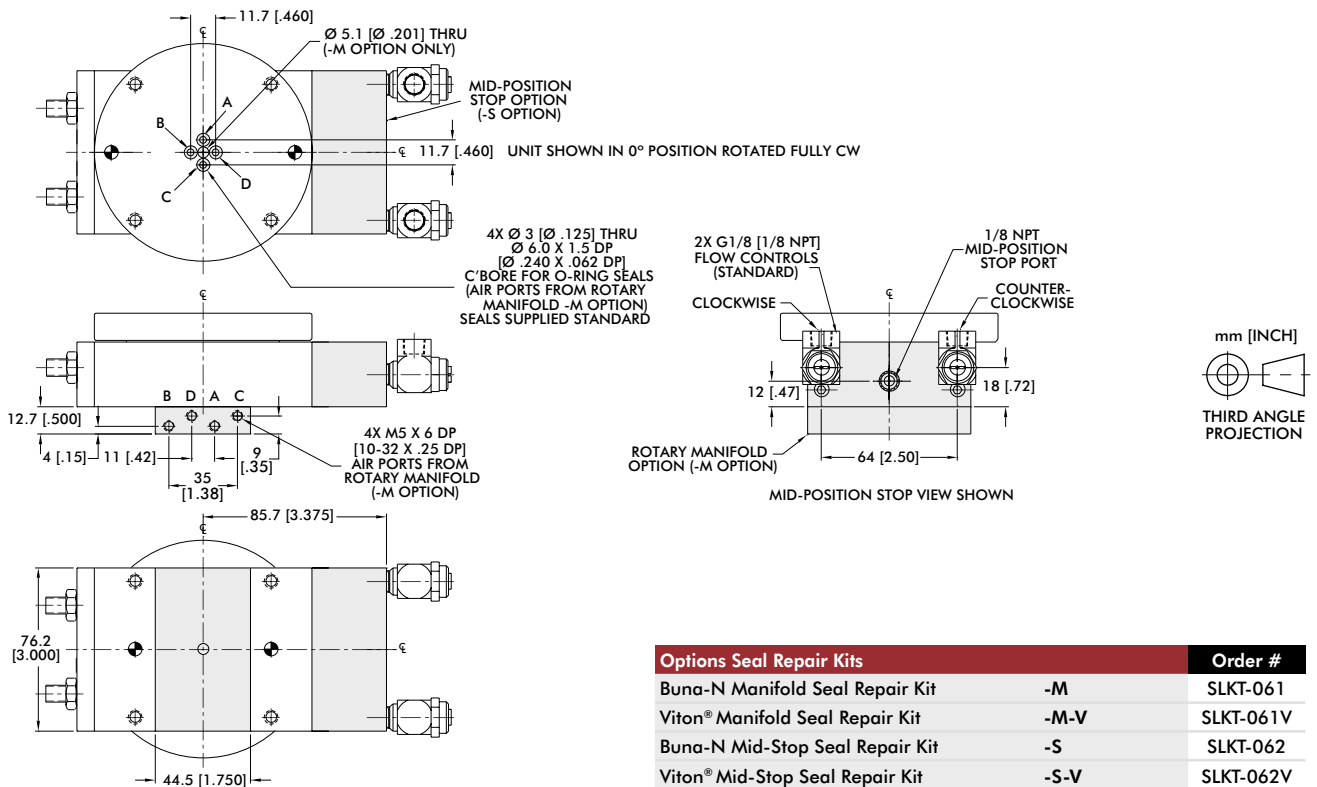

Options Seal Repair Kits		Order #
Buna-N Manifold Seal Repair Kit	-M	SLKT-061
Viton® Manifold Seal Repair Kit	-M-V	SLKT-061V
Buna-N Mid-Stop Seal Repair Kit	-S	SLKT-062
Viton® Mid-Stop Seal Repair Kit	-S-V	SLKT-062V

Rotary Actuators | Dimensions and Technical Specifications

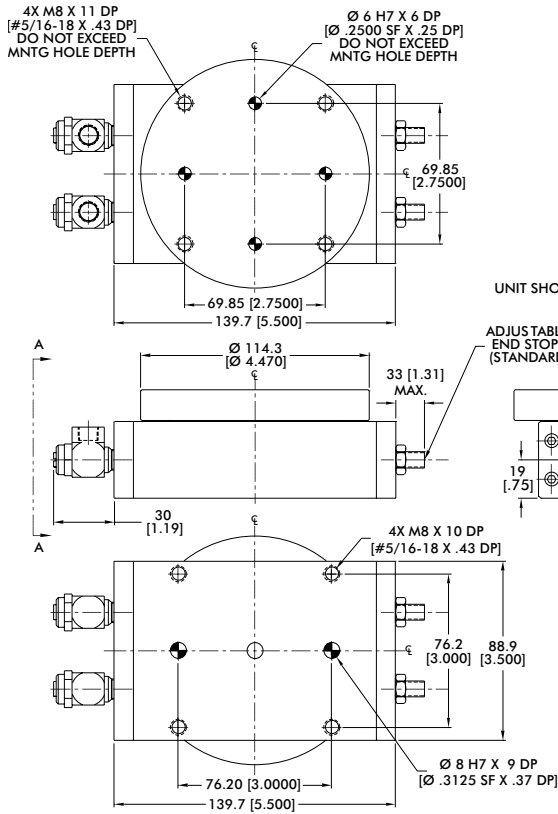
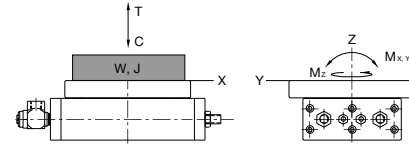

RR-46 Loading Information	Static
Maximum Tensile T	890 N [200 lbs]
Maximum Compressive C	4448 N [1000 lbs]
Maximum Moment M_x	57 Nm [500 in-lbs]
Maximum Moment M_y	57 Nm [500 in-lbs]
Maximum Payload W	6.8 kg [15 lbs]
Maximum Inertia J	0.01096 N-m-sec ² [0.0970 in-lbs-sec ²]

Base Unit Seal Repair Kits	Order #
Buna-N Seal Repair Kit	SLKT-017
Viton® Seal Repair Kit	SLKT-017V

Options Dimensions

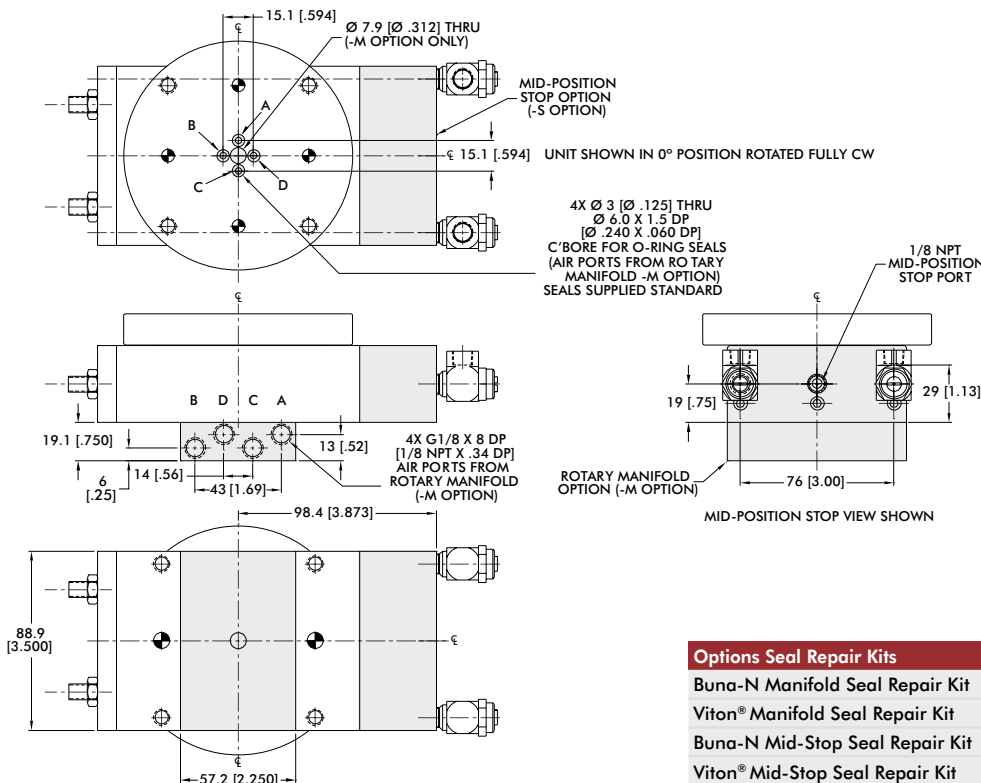

Options Seal Repair Kits		Order #
Buna-N Manifold Seal Repair Kit	-M	SLKT-067
Viton® Manifold Seal Repair Kit	-M-V	SLKT-067V
Buna-N Mid-Stop Seal Repair Kit	-S	SLKT-068
Viton® Mid-Stop Seal Repair Kit	-S-V	SLKT-068V

RR HEAVY-DUTY SERIES

Rotary Actuators | Features and Benefits | How To Order

Features:

- Compact large capacity, high torque for tight space applications
- Use in heavy duty industrial and foundry applications
- Mount payload directly to flange without additional support
- Preloaded bearings for high repeatability rotary actuation
- Zero backlash & precision slip fit dowel pins
- Adjustable flow controls
- Optional manifold eliminates twisted airlines
- 3 position rotary with option mid-stop

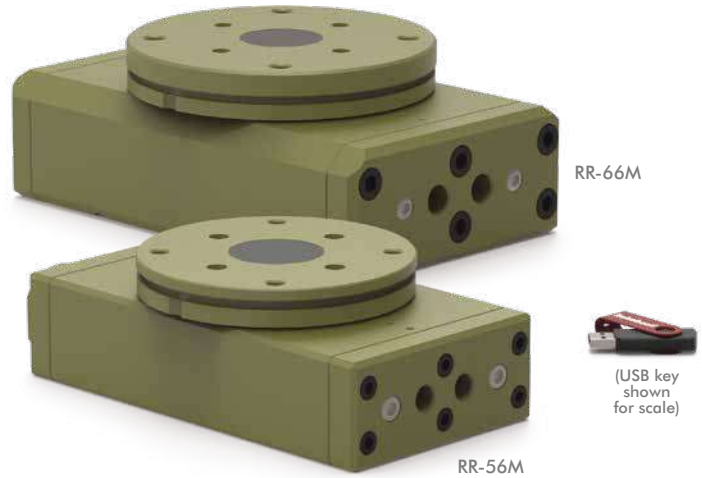

Applications:

- Large torque application
- Foundry applications
- Load and unload

How To Order

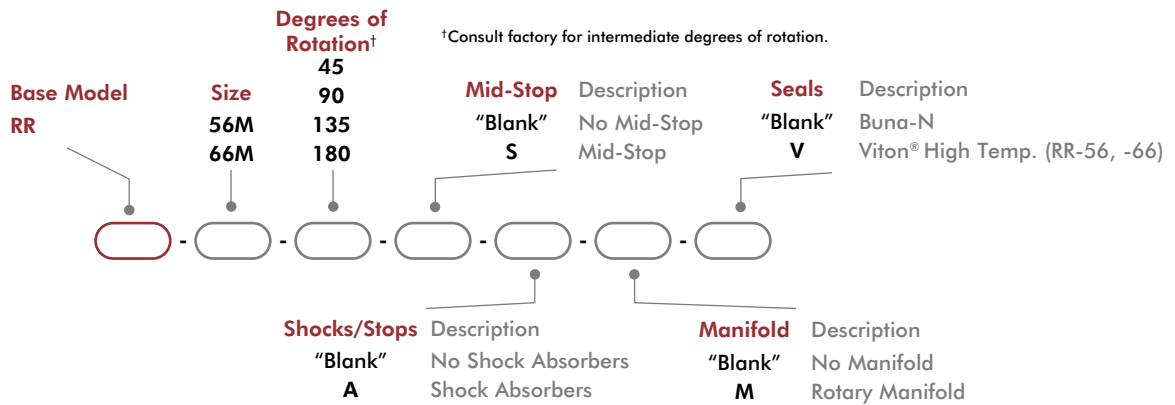

Accessories

Sensor Accessories	Model Numbers	Part Number	Qty/Unit
Inductive Sensor Mounting Kit (mounts 2 sensors)	-56, -66	OSMK-075	1
Magneto Resistive Sensor Mounting Kit (mounts 2 sensors)	-56, -66	OSMK-069	1
NPN Inductive Sensor with Quick Disconnect*	-56, -66	OISN-011	1-2
PNP Inductive Sensor with Quick Disconnect*	-56, -66	OISP-011	1-2
NPN Magneto Resistive Sensor with Quick Disconnect*	-56, -66	OHSN-017	1-2
PNP Magneto Resistive Sensor with Quick Disconnect*	-56, -66	OHSP-017	1-2
Quick Disconnect 2 Meter Cable Length*	-56, -66	CABL-010	1-2
Quick Disconnect 5 Meter Cable Length*	-56, -66	CABL-013	1-2

Pneumatic Accessories	Model Numbers	Part Number	Qty/Unit
G 1/4 BSPP Flow Controls	-56	VLVF-010	2
G 3/8 BSPP Flow Control	-66	VLVF-012	2

*Sensor and cable sold separately.

RR HEAVY-DUTY SERIES

Rotary Actuators | Technical Specifications

Specifications	Units	56	66
Maximum Payload [†]	kg [lb]	13.6 [30]	34 [75]
Maximum Payload Inertia [†]	Nm sec ² [in-lbs sec ²]	0.02880 [0.2549]	0.11584 [1.0251]
Maximum Rotation		180°	
Maximum Torque Mid-Stroke @ 100psi/7 bar	Nm [lbs-in]	35 [311]	82 [728]
Maximum Torque End-Stroke @ 100psi/7 bar	Nm [lbs-in]	17 [155]	41 [364]
Weight (base unit)	kg [lb]	5.3 [11.6]	11.8 [26]
Weight Adder for Mid-Position Stop	kg [lb]	0.82 [1.8]	0.82 [1.8]
Weight Adder for Rotary Manifold	kg [lb]	0.54 [1.2]	0.36 [0.82]
Pressure Range	bar [psi]	3-7 [40-100]	
Ingress Protection Class (IP)		IP55	
Displacement	cm ³ [in ³]	160.1 [9.77]	375 [22.8]
Displacement of Mid-Position Stop	cm ³ [in ³]	90.16 [5.502]	60.32 [2.375]
Temperature Range (Buna-N seals)		0°~66° [-32°~150°]	
Temperature Range (Viton® seals)	°C [°F]		
Actuation Time (180° @ 100psi/7 bar)	sec	0.48	0.70
Actuation Time (90° @ 100psi/7 bar)	sec	0.40	0.50
End-Stop Repeatability		±0.02°	
Mid-Stop Repeatability		±0.5°	
End-Stop Adjustability*		30°	20°
Over Travel (each end)		4°	
Valve required to actuate		4-way, 2-position	
Valve required to actuate Mid-Stop		3-way, 2-position	

[†] Max. payload based on -A shock option.

*Any adjustment of the End Stop Adjustment Screw must be accompanied by an equal adjustment of the Shock Absorbers to prevent bottoming of the pistons against the Shock Absorbers.

RR-56

Rotary Actuators | Dimensions and Technical Specifications

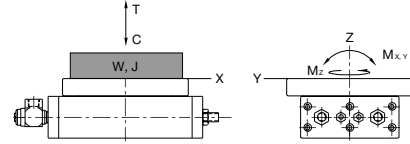
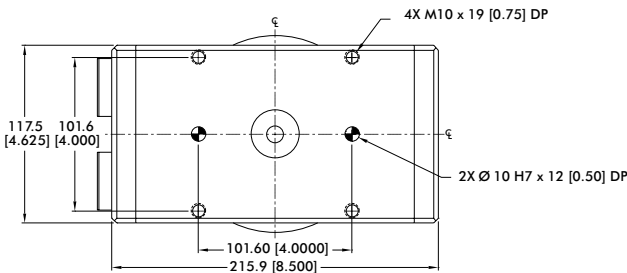
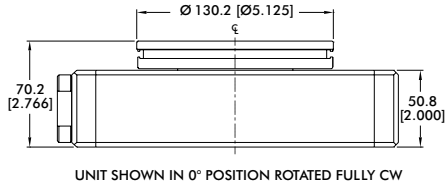
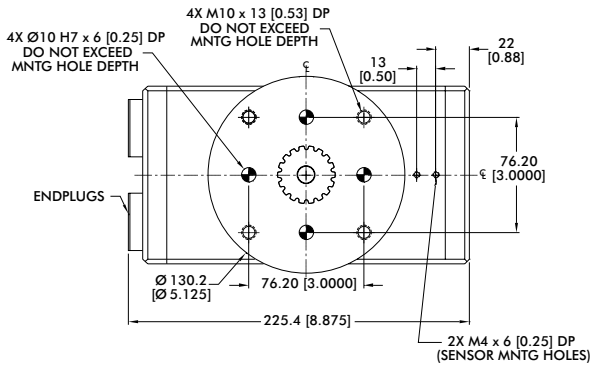

RR-56 Loading information	Static
Maximum Tensile T	3559 N [800 lbs]
Maximum Compressive C	8896 N [2000 lbs]
Maximum Moment M_x	113 Nm [1000 in-lbs]
Maximum Moment M_y	113 Nm [1000 in-lbs]
Maximum Payload $W^†$	13.64 kg [30 lbs]
Maximum Inertia $J^†$	0.0288 N-m-sec ² [0.2549 in-lbs-sec ²]

[†]Max. payload based on -A shock option.

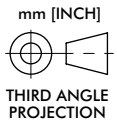
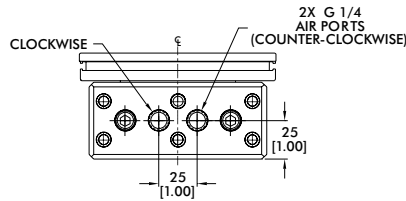

Base Unit Seal Repair Kits	Order #
Buna-N Seal Repair Kit	SLKT-124
Viton® Seal Repair Kit	SLKT-124V

Options Dimensions

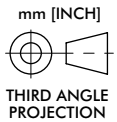
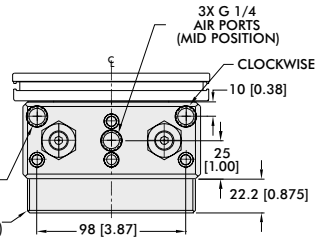
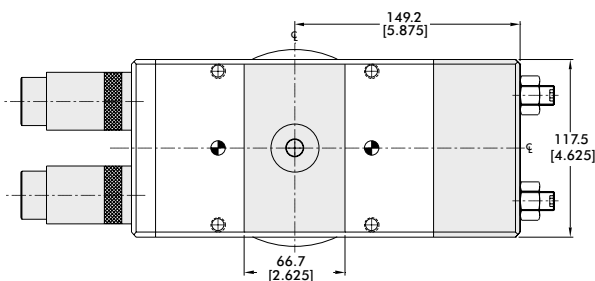
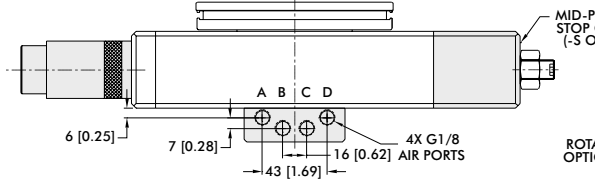
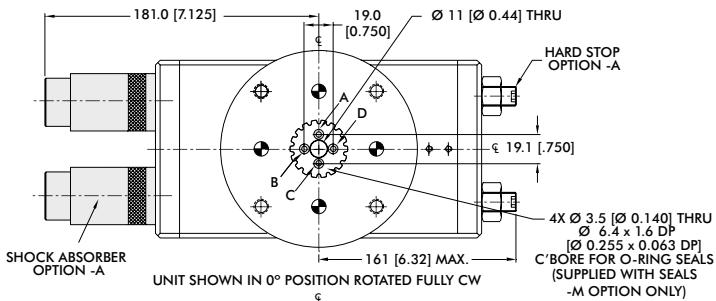

Options Seal Repair Kits		Order #
Buna-N Manifold Seal Repair Kit	-M	SLKT-126
Viton® Manifold Seal Repair Kit	-M-V	SLKT-126V
Buna-N Mid-Stop Seal Repair Kit	-S	SLKT-127
Viton® Mid-Stop Seal Repair Kit	-S-V	SLKT-127V
Buna-N Shock Seal Repair Kit	-A	SLKT-125
Viton® Shock Seal Repair Kit	-A-V	SLKT-125V

Rotary Actuators | Dimensions and Technical Specifications

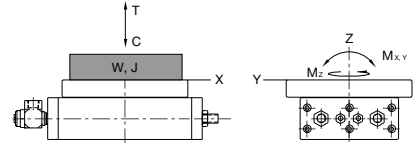
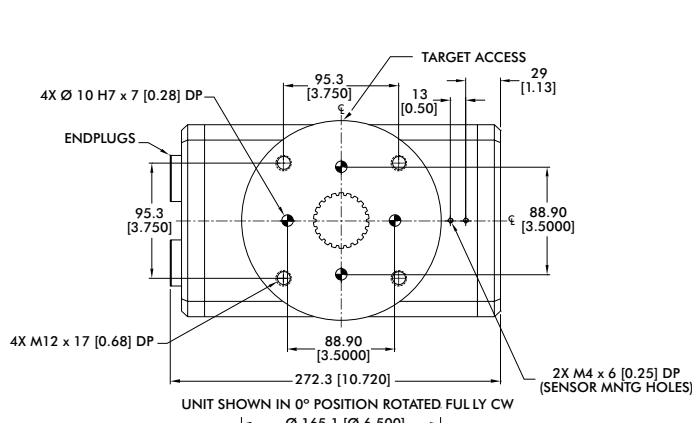

RR-66 Loading Information	Static
Maximum Tensile T	4448 N [1000 lbs]
Maximum Compressive C	15569 N [3500 lbs]
Maximum Moment M_x	226 Nm [2000 in-lbs]
Maximum Moment M_y	226 Nm [2000 in-lbs]
Maximum Payload W^\dagger	34 kg [75 lbs]
Maximum Inertia J^\dagger	0.1158 N-m-sec ² [1.025 in-lbs-sec ²]

[†]Max. payload based on -A shock option.

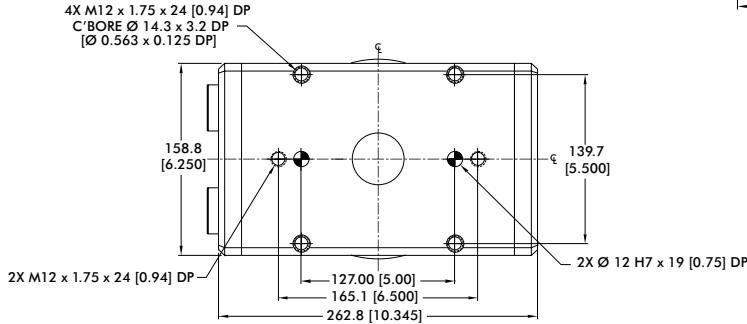
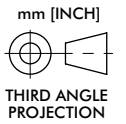
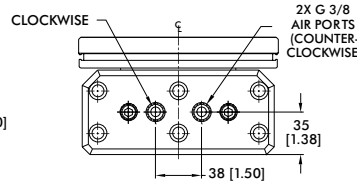

Base Unit Seal Repair Kits	Order #
Buna-N Seal Repair Kit	SLKT-128
Viton® Seal Repair Kit	SLKT-128V

Options Dimensions

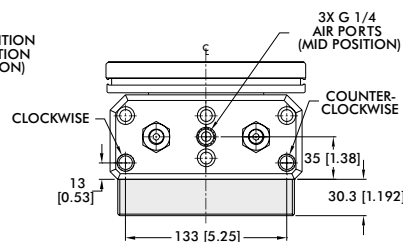
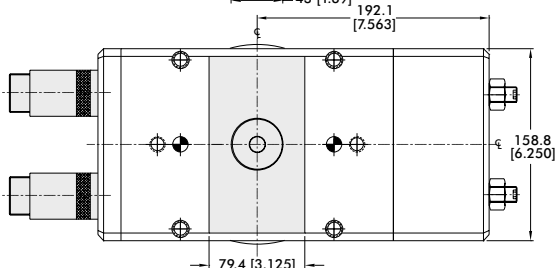
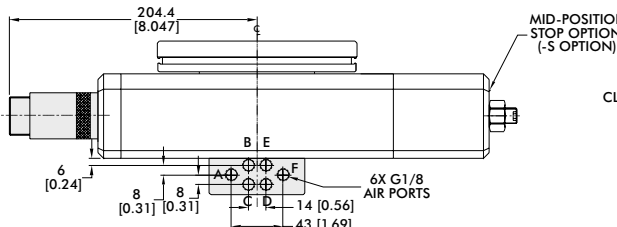
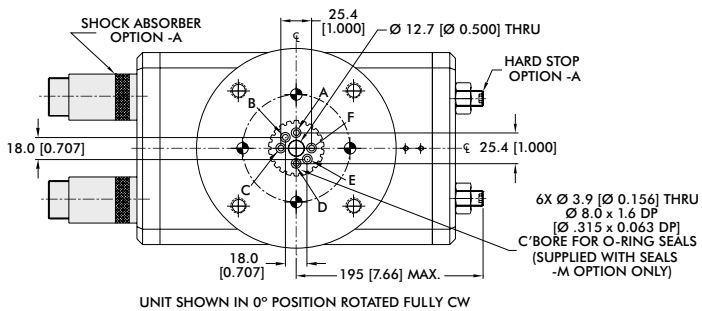



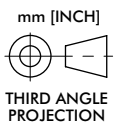

MID-POSITION STOP VIEW SHOWN



Options Seal Repair Kits		Order #
Buna-N Manifold Seal Repair Kit	-M	SLKT-130
Viton® Manifold Seal Repair Kit	-M-V	SLKT-130V
Buna-N Mid-Stop Seal Repair Kit	-S	SLKT-131
Viton® Mid-Stop Seal Repair Kit	-S-V	SLKT-131V
Buna-N Shock Seal Repair Kit	-A	SLKT-129
Viton® Shock Seal Repair Kit	-A-V	SLKT-129V

LINEAR SLIDES

Linear Slides | Product Overview | DIRECTCONNECT™ Mounting

	Model	Stroke mm [in]	Thrust Force N [lbs]	Operating Environment	Special Features	Page GR-LIN-#
DLB		6-500 [0.25-26]	89-560 [20-126]	IP54	High Reliability with smooth operation base slide. Internal or external air cylinder options. DIRECTCONNECT	3
DLT		6-700 [0.25-28]	89-560 [20-126]	IP54	High Reliability with smooth operation Thrust slide. Internal or external air cylinder options. DIRECTCONNECT	19
DLM		5-100 [0.2-4]	67-230 [15-52]	IP54	Precise positioning with stroke adjustments. High load and moment capacity. DIRECTCONNECT	41
MPS		13-51 [0.5-2]	67-196 [15-44]	IP54	Compact slide with zero side play. Dual-V bearing design. Adjustable stops.	47

DIRECTCONNECT Modular Direct Mounting System without Adapter Plates

Products can be mounted in multiple positions. Refer to datasheet for complete info.

Slide to Slide

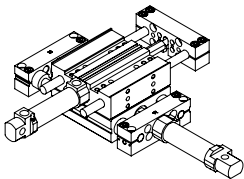

DLB Base Slide to
DLT Thruster Slide

Slide to Slide

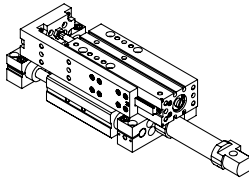

DLB Base Slide to
DLM Thruster Slide

Slide to Gripper

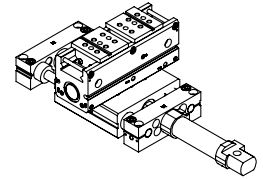

DLB Base Slide to
DPG Parallel Gripper

Slide to Slide

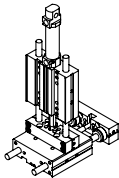

DLT Thruster Slide to
DLT Thruster Slide

Slide to Slide

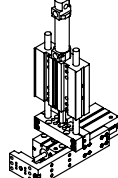

DLT Thruster Slide to
DLM Thruster Slide

Slide to Gripper

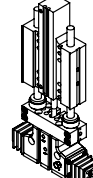

DLT Thruster Slide to
DPDL Parallel Gripper

Slide to Slide

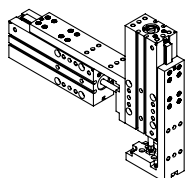

DLM Thruster Slide to
DLM Thruster Slide

Slide to Slide

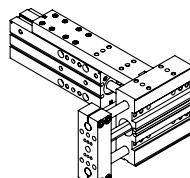

DLM Thruster Slide to
DLT Thruster Slide

Slide to Gripper

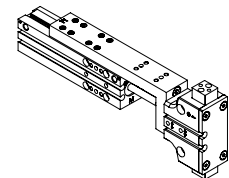

DLM Thruster Slide to
DPDL Parallel Gripper

LINEAR SLIDES

Linear Slides | DIRECTCONNECT™ Mounting Compatibility Chart

DESTACO's DIRECTCONNECT™ technology, allows all components of the system—grippers and slides—to be mounted together directly. Look for matching icons on product datasheets for mounting compatibility.

Note: The numbers in the cell represent the metric screw size and basic mounting pattern.

S=Square, R=Rectangle. ie; 5S = M5 Screw with square mounting pattern.

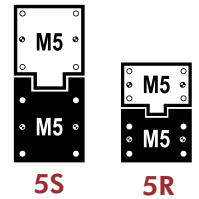

Catalog Models		Base Slides			Thruster Slides				
		DLB-06&08	DLB-10,12,16	DLB-20&25	DLT-06&08	DLT-10,12,16	DLT-20&25	DLM-07	DLM-09&12
Base Slides	DLB-06,08				3R,3S			3R,3S	
	DLB-10,12,16				3S	5R,5S		3S	5R,5S
	DLB-20,25					5S	10R,10S		5S
Thruster Slides	DLT-06,08	3R,3S	3S		3R	3R		3R	3R
	DLT-10,12,16		5R,5S	5S		5R	5R		5R
	DLT-20,25			10R,10S			10R		
	DLM-07	3R,3S	3S		3R	3R		3R	3R
	DLM-9,12		5R,5S	5S		5R	5R		5R
Grippers	DGC		5R			5R	5R		5R
	DPG		5R			5R	5R		5R
	DCT-12, 16,25	3R			3R	3R		3R	3R
	DCT-25		5R			5R	5R		5R
	DPDL-047,056	3R			3R	3R		3R	3R
	DPDL-088,125		5R			5R	5R		5R
	DPDL-175,250			10R			10R		
	DPDS-047,056	3R			3R	3R		3R	3R
	DPDS-088,125		5R			5R	5R		5R
	DPDS-175,250			10R			10R		
	DPL-25xx		5R			5R	5R		5R
	DPL-32xx,40xx			10R			10R		
	DPP-10,14	3R			3R	3R		3R	3R
	DPP-20		5R			5R	5R		5R
	DPP-28		5R	10R		5R	10R		5R
	DPW-250	3R			3R	3R		3R	3R
	DPW-375,500		5R			5R	5R		5R
	G100-08,011	3R			3R	3R		3R	3R
	G100-18,25		5R			5R	5R		5R
	DPE-200		5R			5R	5R		5R
DPE-400			10R			10R			

DLB SERIES - INTERNAL AIR CYLINDER

Internal Air Cylinder Linear Base Slides | Features and Benefits | How To Order

Features:

- Bearing system for smooth operation
- Rugged design produces very reliable long life operation
- Internal air cylinder for space-limited applications
- Telescopic airlines, shocks and hard stops available
- Viton® seals for high temp applications
- Corrosion resistant shafting for corrosive environments
- Inductive sensing for position detection
- Custom stroke lengths available.

Applications:

- Machining and automation applications
- Harsh environment pick-and-place applications
- OEM machines

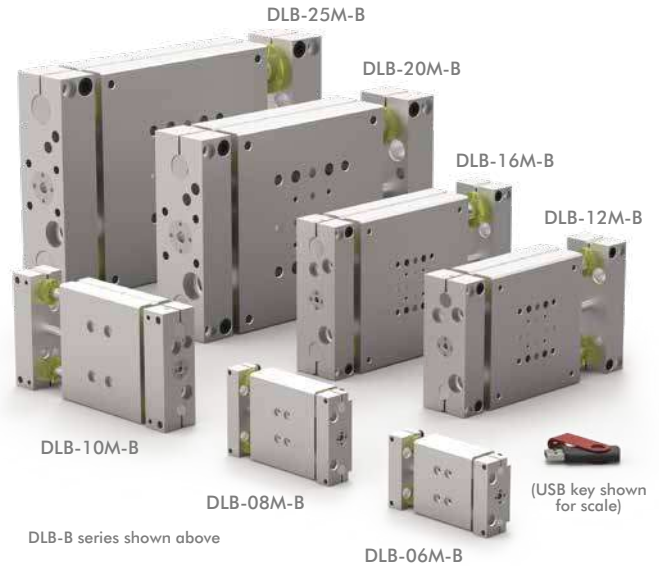

DLB-B series shown above

(USB key shown for scale)

How To Order

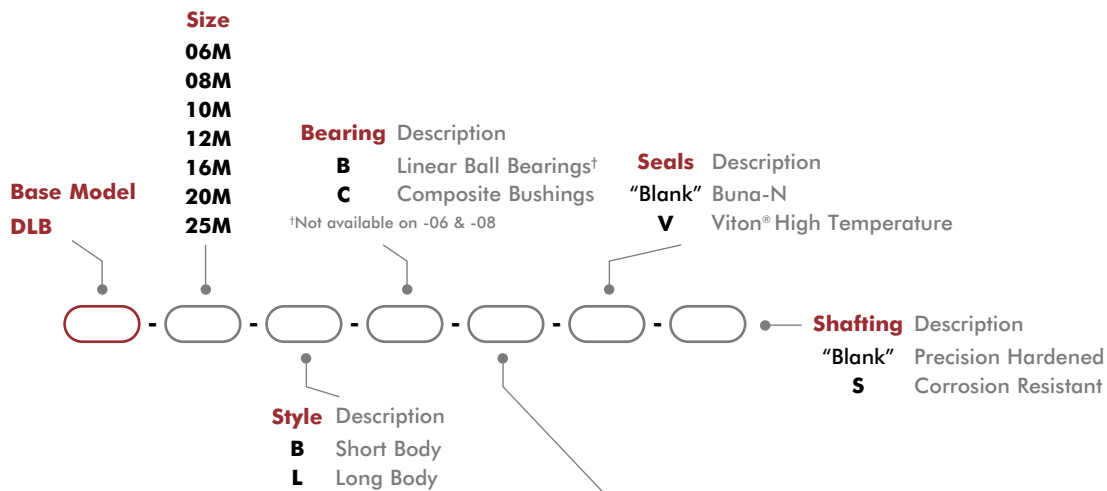

-B Style	Stroke* Metric (mm)	-L Style	Stroke* Metric (mm)
DLB-06M-B	6, 12, 25, 30	DLB-06M-L	12, 25, 40, 50, 65, 75
DLB-08M-B	6, 12, 25, 40, 44	DLB-08M-L	12, 25, 40, 50, 65, 75, 85
DLB-10M-B	25, 50	DLB-10M-L	25, 50, 80, 100
DLB-12M-B	25, 50	DLB-12M-L	25, 50, 80, 100, 125
DLB-16M-B	25, 50, 80	DLB-16M-L	25, 50, 80, 100, 125, 150
DLB-20M-B	25, 50, 80, 100	DLB-20M-L	25, 50, 80, 100, 125, 160
DLB-25M-B	25, 50, 80, 100, 125	DLB-25M-L	25, 50, 80, 100, 125, 160, 175

*Custom strokes available. Consult factory.

*Custom strokes available. Consult factory.

DLB SERIES - INTERNAL AIR CYLINDER

Internal Air Cylinder Linear Base Slides | Accessories and Technical Specifications

Shock/Stop Accessories	Model Numbers	Style	Part Number	Qty/Unit
Shock Absorber	06, 08	ALL	SHOK-030	1-2
	10		SHOK-028	
	12, 16,		SHOK-010	
	20, -25		SHOK-029	
Adjustable Hard Stop	06, 08	ALL	DLT-0623	1-2
	10, 12, 16, 20, 25		DLT-1023	
Sensor Accessories	Model Numbers	Style	Part Number	Qty/Unit
PNP Inductive Sensor with Quick Disconnect*	All Models	ALL	OISP-011	1-2
NPN Inductive Sensor with Quick Disconnect*			OISN-011	
Quick Disconnect 2 Meter Cable Length*			CABL-010	
Quick Disconnect 5 Meter Cable Length*			CABL-013	
Pneumatic Accessories	Model Numbers	Style	Part Number	Qty/Unit
G1/8 Telescopic Airlines (up to 50mm)	10, 12, 16	B	OTAL-043	1-4
G1/8 Telescopic Airlines (up to 80mm)	10, 12, 16		OTAL-044	
G1/8 Telescopic Airlines (up to 100mm)	10, 12, 16	L	OTAL-051	
G1/8 Telescopic Airlines (up to 125mm)	10, 12, 16		OTAL-052	
G1/8 Telescopic Airlines (up to 160mm)	10, 12, 16, 20, 25	L	OTAL-045	1-2
G1/8 Telescopic Airlines (up to 300mm)	20, 25		OTAL-046	
M5 Adjustable Flow Control	06, 08, 10, 12, 16	ALL	VLVF-008	
G 1/8 Adjustable Flow Control	20, 25		VLVF-005	
Cylinder Seal Kit (Buna-N)	06, 08		SLKT-109	1
	10		SLKT-101	
	12, 16	SLKT-103		
	20, 25	SLKT-105		
Cylinder Seal Kit (Viton®)	06, 08	SLKT-109V	1	
	10	SLKT-101V		
	12, 16	SLKT-103V		
	20, 25	SLKT-105V		

*Sensor and cable sold separately.

See page GR-LIN-35 for Accessory Mounting Technical Data.

Specifications

Specifications	Units	06	08	10	12
Max. Air Pressure	bar [psi]	7 [100]			
Thrust Force @ 5.5 bar [80psi]	N [lbs]	89 [20]		129 [29]	254 [57]
Weight (basic unit) -B	kg [lb]	0.20 [0.44]	0.36 [0.79]	0.93 [2.08]	1.7 [3.83]
Weight (basic unit) -L	kg [lb]	0.32 [0.71]	0.56 [1.24]	1.50 [3.34]	2.30 [5.13]
Additional Weight per Stroke -B	g/mm [lbs/in]	0.53 [0.03]	0.88 [0.05]	1.4 [0.08]	2.1 [0.12]
Cylinder Bore Ø	mm [in]	14.29 [0.563]		19 [0.75]	25 [1.00]
Shaft Ø	mm [in]	6 [0.236]	8 [0.315]	9.5 [0.375]	12 [0.472]

Specifications	Units	16	20	25
Max. Air Pressure	bar [psi]	7 [100]		
Thrust Force @ 5.5 bar [80psi]	N [lbs]	254 [57]	560 [126]	560 [126]
Weight (basic unit) -B	kg [lb]	2.4 [5.19]	5.9 [13.0]	8.2 [18.2]
Weight (basic unit) -L	kg [lb]	3.30 [7.30]	7.1 [15.6]	9.7 [21.4]
Additional Weight per Stroke -B	g/mm [lbs/in]	3.3 [0.19]	5.54 [0.32]	8.4 [0.47]
Cylinder Bore Ø	mm [in]	25 [1.00]	38 [1.5]	38 [1.5]
Shaft Ø	mm [in]	16 [0.630]	20 [0.787]	25 [0.984]

Internal Air Cylinder Linear Base Slides | Dimensions and Technical Specifications

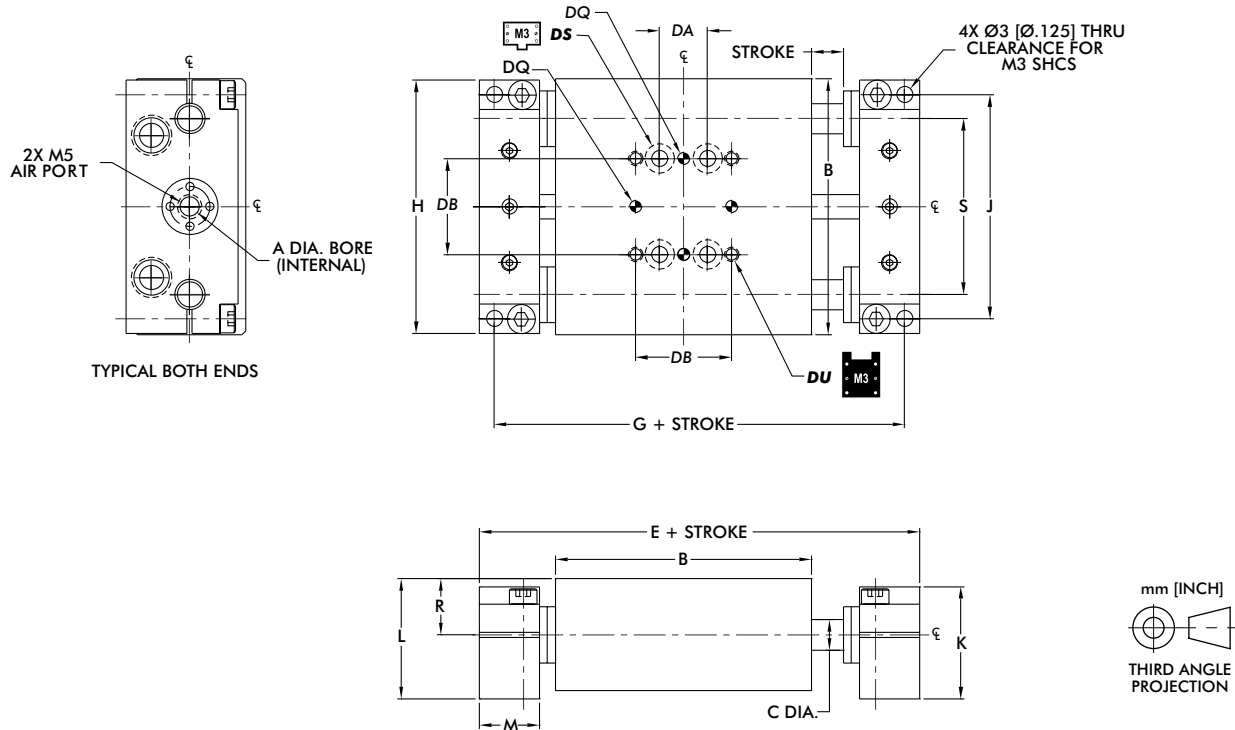

DIRECTCONNECT™ Mounting Pattern Dimensions (all sizes)				
DA	DB	DQ	DS	DU
9.5 [0.375]	19.1 [0.750]	3H7 x 2 DP	CLR & C'BORE FOR M3	M3 x 6 DP

Model	Bore Ø	Body Size	Shaft Ø	Basic Unit Dimensions								
	A	B	C	E	G	H	J	K	L	M	R	S
DLB-06M	14 [0.563]	50.8 [2.000]	6.0 [0.236]	81.0 [3.19]	75.1 [2.956]	50.3 [1.980]	44.4 [1.750]	22.2 [0.875]	23.7 [0.936]	11.9 [0.470]	11.13 [0.438]	34.93 [1.375]
DLB-08M		63.5 [2.500]	8.0 [0.315]	93.7 [3.69]	87.8 [3.456]	62.7 [2.470]	57.1 [2.250]					44.45 [1.750]

Dimensions in mm [in]

Loading Information

- F**=Externally applied force
- W**=Weight of payload
- F+W**=Total force
- M**=Maximum moment

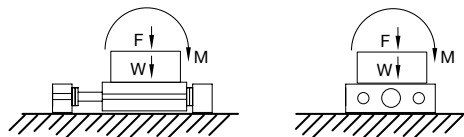

	06	08
Maximum Payload (W) horizontal motion using Shock Absorbers	1.4 kg [3 lbs]	2.3 kg [5 lbs]
Maximum Payload (W) vertical motion using Shock Absorbers	0.7 kg [1.5 lbs]	1.1 kg [2.5 lbs]
Maximum Payload (W) horizontal motion using Urethane Bumpers	0.5 kg [1 lbs]	0.5 kg [1 lbs]
Maximum Total Applied Load + Payload (F+W)	45 N [10 lbs]	53.4 N [12 lbs]
Total Maximum Moment about any Axis (M)	1.7 Nm [15 in-lbs]	3.4 Nm [30 in-lbs]

Shock Absorbers and Flow Controls are recommended for all applications

Internal Air Cylinder Linear Base Slides | Dimensions and Technical Specifications

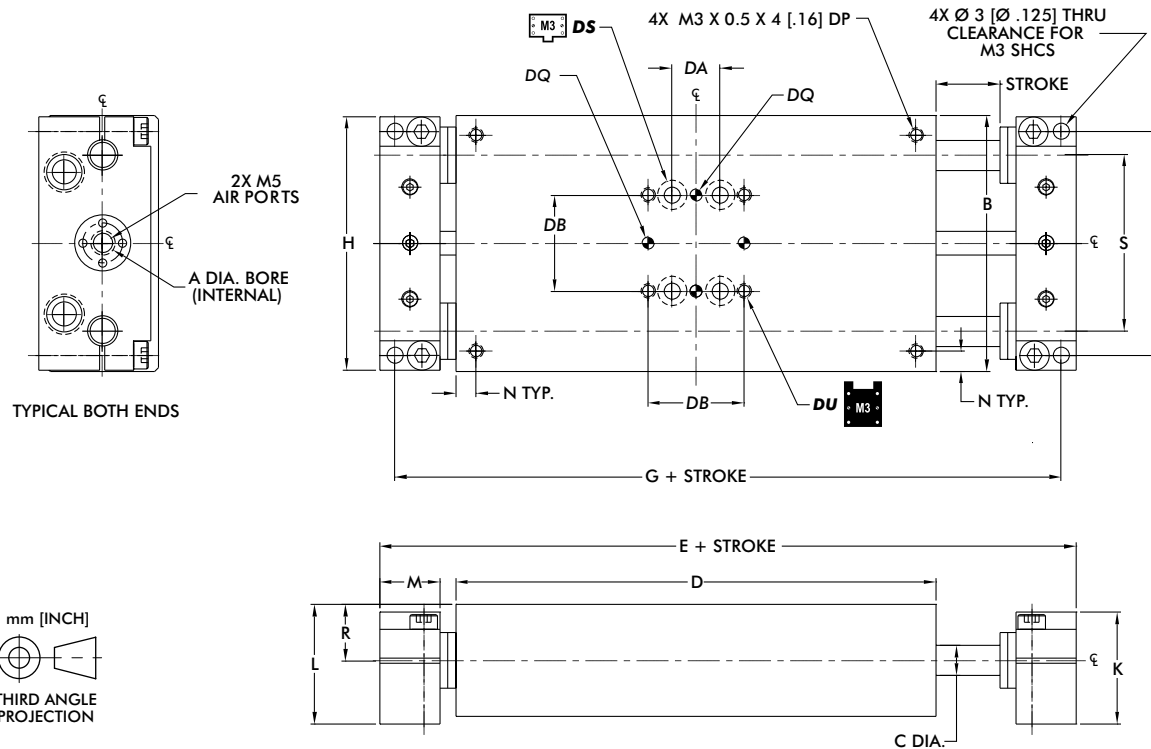

mm [INCH]
THIRD ANGLE PROJECTION

DIRECTCONNECT™ Mounting Pattern Dimensions (all sizes)				
DA	DB	DQ	DS	DU
9.5 [0.375]	19.1 [0.750]	3H7 x 2 DP	CLR & C'BORE FOR M3	M3 x 6 DP

Model	Bore Ø	Body Size	Shaft Ø	Basic Unit Dimensions										
				A	B	C	D	E	G	H	J	K	L	M
DLB-06M	14 [0.563]	50.8 [2.00]	6.0 [0.236]	95.2 [3.75]	125.5 [4.94]	119.6 [4.71]	50.3 [1.980]	44.4 [1.750]	22.2 [0.875]	23.7 [0.936]	11.9 [0.470]	3.96 [0.156]	11.13 [0.438]	34.93 [1.375]
DLB-08M		63.5 [2.50]	8.0 [0.315]	107.9 [4.25]	138.2 [5.44]	132.2 [5.206]	62.7 [2.470]	57.1 [2.250]						44.45 [1.750]

Dimensions in mm [in]

Loading Information

F=Externally applied force
W=Weight of payload
F+W=Total force
M=Maximum moment

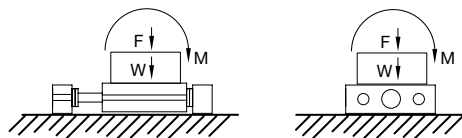

	06	08
Maximum Payload (W) horizontal motion using Shock Absorbers	1.4 kg [3 lbs]	2.3 kg [5 lbs]
Maximum Payload (W) vertical motion using Shock Absorbers	0.7 kg [1.5 lbs]	1.1 kg [2.5 lbs]
Maximum Payload (W) horizontal motion using Urethane Bumpers	0.5 kg [1 lbs]	0.5 kg [1 lbs]
Maximum Total Applied Load + Payload (F+W)	45 N [10 lbs]	53.4 N [12 lbs]
Total Maximum Moment about any Axis (M)	1.7 Nm [15 in-lbs]	3.4 Nm [30 in-lbs]

Shock Absorbers and Flow Controls are recommended for all applications

DLB-10/12/16M-B

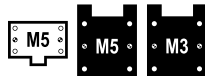

Internal Air Cylinder Linear Base Slides | Dimensions and Technical Specifications

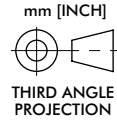
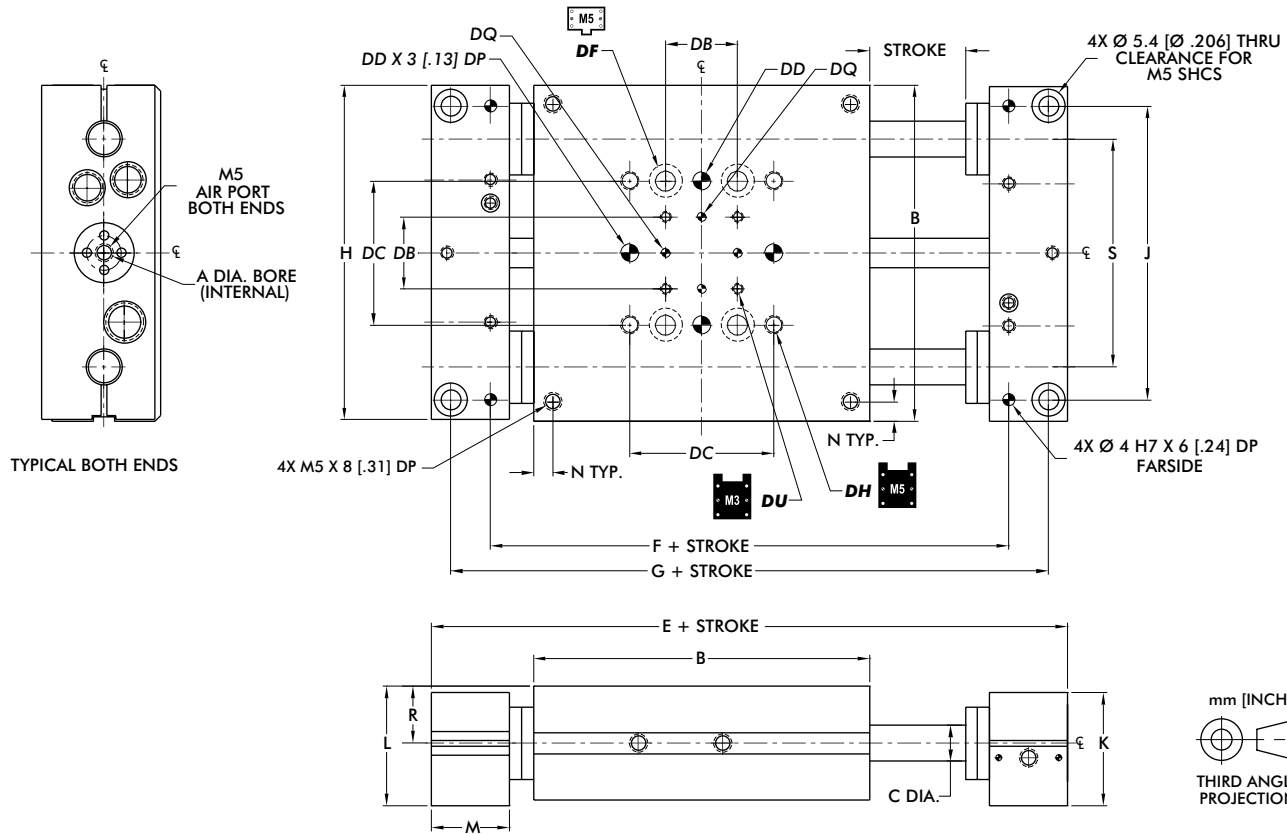

DIRECTCONNECT™ Mounting Pattern Dimensions (all sizes)						
DB	DC	DD	DF	DH	DQ	DU
19.1 [0.750]	38.1 [1.500]	5mm H7 x 6 DP	CLEARANCE FOR M5	M5 x 8.5DP	3H7 x 2 DP	M3 x 6 DP

Model	Bore Ø Body Size Shaft Ø			Basic Unit Dimensions										
	A	B	C	E	F	G	H	J	K	L	M	N	R	S
DLB-10M	19 [0.75]	88.9 [3.50]	9.5 [0.375]	143.0 [5.63]	111.70 [4.3975]	132.8 [5.228]	88.5 [3.485]	77.72 [3.0600]	29.9 [1.178]	31.6 [1.245]		N/A	15.09 [0.594]	60.33 [2.375]
DLB-12M	25 [1.00]	101.6 [4.00]	12 [0.472]	155.7 [6.13]	124.40 [4.8975]	145.5 [5.728]	101.2 [3.985]	88.90 [3.5000]	41.0 [1.615]	42.1 [1.657]	20.7 [0.813]	9.5 [0.375]	20.65 [0.813]	69.85 [2.750]
DLB-16M		120.7 [4.75]	16 [0.630]	174.8 [6.88]	143.45 [5.6475]	164.5 [6.478]	120.3 [4.735]	107.95 [4.2500]						

Dimensions in mm [in]

Loading Information

- F**=Externally applied force
- W**=Weight of payload
- F+W**=Total force
- M**=Maximum moment

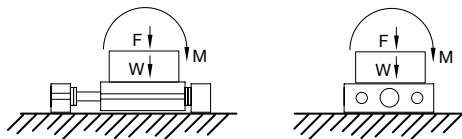

	10	12	16
Maximum Payload (W) horizontal motion using Shock Absorbers	6.8 kg [15 lbs]	13.6 kg [30 lbs]	20.4 kg [45 lbs]
Maximum Payload (W) vertical motion using Shock Absorbers	3.1 kg [7 lbs]	6.8 kg [15 lbs]	9.9 kg [22 lbs]
Maximum Payload (W) horizontal motion using Urethane Bumpers	2.2 kg [5 lbs]	4.5 kg [10 lbs]	6.8 kg [15 lbs]
Maximum Total Applied Load + Payload (F+W)	111 N [25 lbs]	178 N [40 lbs]	311 N [70 lbs]
Total Maximum Moment about any Axis (M)	8.4 Nm [75 in-lbs]	16.9 Nm [150 in-lbs]	33.9 Nm [300 in-lbs]

Shock Absorbers and Flow Controls are recommended for all applications

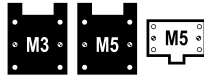

Internal Air Cylinder Linear Base Slides | Dimensions and Technical Specifications

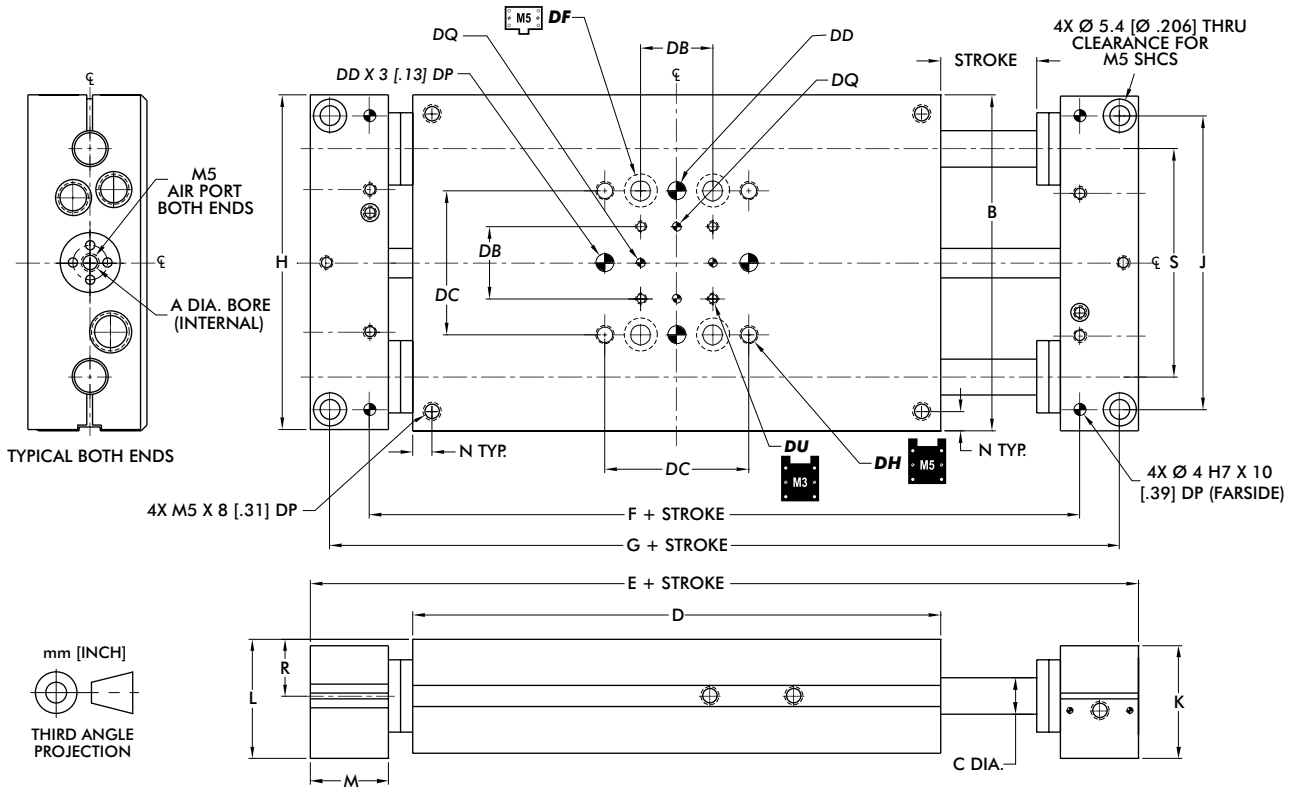

DIRECTCONNECT™ Mounting Pattern Dimensions (all sizes)

DB	DC	DD	DF	DH	DQ	DU
19.1 [0.750]	38.1 [1.500]	5mm H7 x 6 DP	CLEARANCE FOR M5	M5 x 8.5DP	3H7 x 2 DP	M3 x 6 DP

Model	Bore Ø			Basic Unit Dimensions											
	A	B	C	D	E	F	G	H	J	K	L	M	N	R	S
DLB-10M	19 [0.75]	88.9 [3.50]	9.5 [0.375]	139.7 [5.50]	193.8 [7.63]	162.50 [6.3975]	183.6 [7.228]	88.5 [3.485]	77.72 [3.0600]	29.9 [1.178]	31.6 [1.245]		N/A	15.09 [0.594]	60.33 [2.375]
DLB-12M	25 [1.00]	101.6 [4.00]	12 [0.472]	165.1 [6.50]	219.2 [8.63]	187.90 [7.3975]	209.0 [8.228]	101.2 [3.985]	88.90 [3.5000]	41.0 [1.615]	42.1 [1.657]	20.7 [0.813]	9.5 [0.375]	20.65 [0.813]	69.85 [2.750]
DLB-16M		120.7 [4.75]	16 [0.630]	190.5 [7.50]	244.6 [9.63]	213.30 [8.3975]	234.4 [9.228]	120.3 [4.735]	107.95 [4.2500]						82.55 [3.250]

Dimensions in mm [in]

Loading Information

- F**=Externally applied force
- W**=Weight of payload
- F+W**=Total force
- M**=Maximum moment

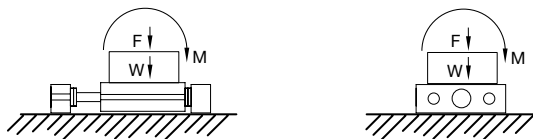

	10	12	16
Maximum Payload (W) horizontal motion using Shock Absorbers	6.8 kg [15 lbs]	13.6 kg [30 lbs]	20.4 kg [45 lbs]
Maximum Payload (W) vertical motion using Shock Absorbers	3.1 kg [7 lbs]	6.8 kg [15 lbs]	9.9 kg [22 lbs]
Maximum Payload (W) horizontal motion using Urethane Bumpers	2.2 kg [5 lbs]	4.5 kg [10 lbs]	6.8 kg [15 lbs]
Maximum Total Applied Load + Payload (F+W)	111 N [25 lbs]	178 N [40 lbs]	311 N [70 lbs]
Total Maximum Moment about any Axis (M)	8.4 Nm [75 in-lbs]	16.9 Nm [150 in-lbs]	33.9 Nm [300 in-lbs]

Shock Absorbers and Flow Controls are recommended for all applications

DLB-20/25M-B



Internal Air Cylinder Linear Base Slides | Dimensions and Technical Specifications

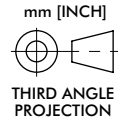
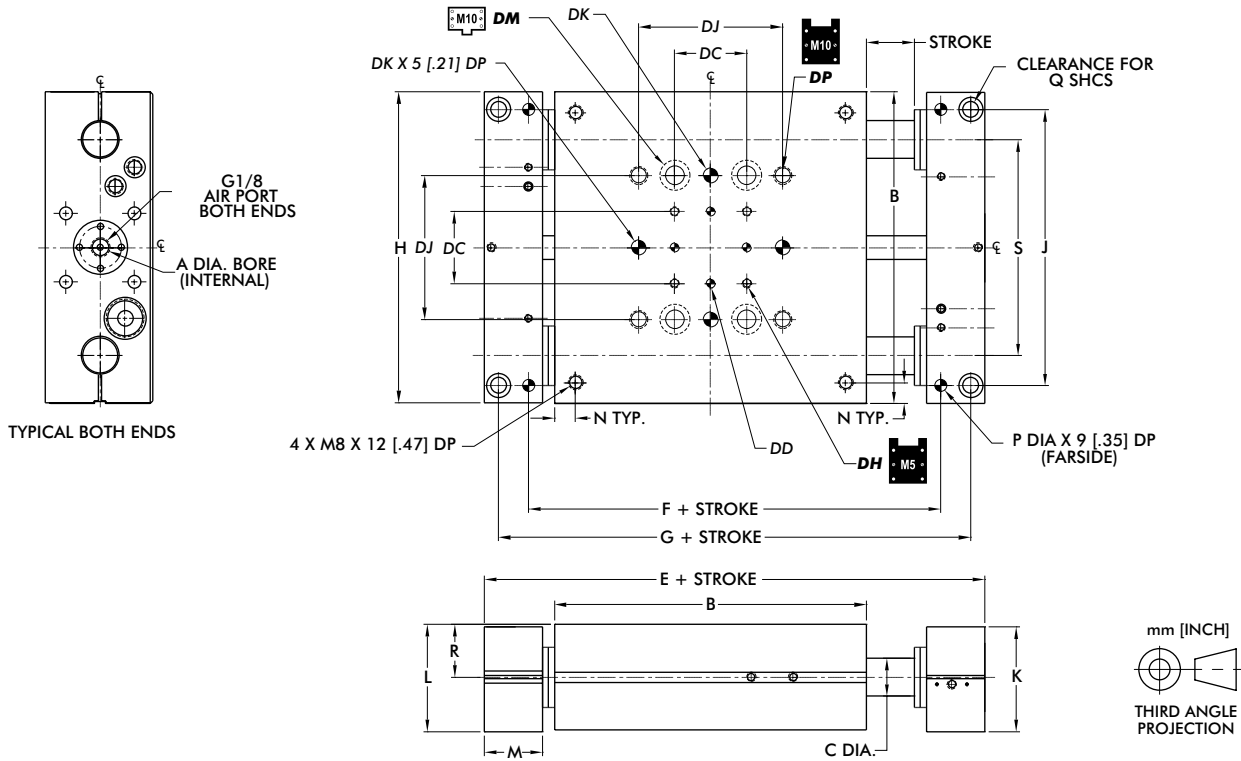

DIRECTCONNECT™ Mounting Pattern Dimensions (all sizes)						
DC	DD	DH	DJ	DK	DM	DP
38.1 [1.500]	5 mm H7 x 6 DP	M5 x 8.5 DP	76.2 [3.000]	8 mm H7 x 9.4 DP	CLR & C'BORE FOR M10	M10 x 12 DP

Model	Bore Ø	Body Size	Shaft Ø	Basic Unit Dimensions												
				A	B	C	E	F	G	H	J	K	L	M	N	P
DLB-20M	38 [1.50]	165.1 [6.50]	20 [0.787]	239.3 [9.42]	192.66 [7.5850]	224.4 [8.836]	164.6 [6.480]	146.05 [5.7500]	55.4 [2.180]	56.8 [2.236]	[1.210] 30.7	11.1 [0.438]	6.00 [0.2505]	M8	27.94 [1.100]	114.30 [4.500]
DLB-25M		190.5 [7.50]	25 [0.984]	275.3 [10.84]	221.79 [8.7320]	256.7 [10.108]	190.0 [7.480]	171.45 [6.7500]			[1.420] 36.1		8.00 [0.3130]			M10

Dimensions in mm [in]

Loading Information

- F=Externally applied force
- W=Weight of payload
- F+W=Total force
- M=Maximum moment

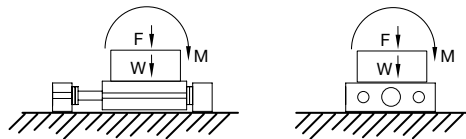

	20	25
Maximum Payload (W) horizontal motion using Shock Absorbers	27.2 kg [60 lbs]	45.3 kg [100 lbs]
Maximum Payload (W) vertical motion using Shock Absorbers	13.6 kg [30 lbs]	22.0 kg [50 lbs]
Maximum Payload (W) horizontal motion using Urethane Bumpers	9.1 kg [20 lbs]	11.3 kg [25 lbs]
Maximum Total Applied Load + Payload (F+W)	444 N [100 lbs]	667 N [150 lbs]
Total Maximum Moment about any Axis (M)	67.7 Nm [600 in-lbs]	135.5 Nm [1200 in-lbs]

Shock Absorbers and Flow Controls are recommended for all applications

Internal Air Cylinder Linear Base Slides | Dimensions and Technical Specifications

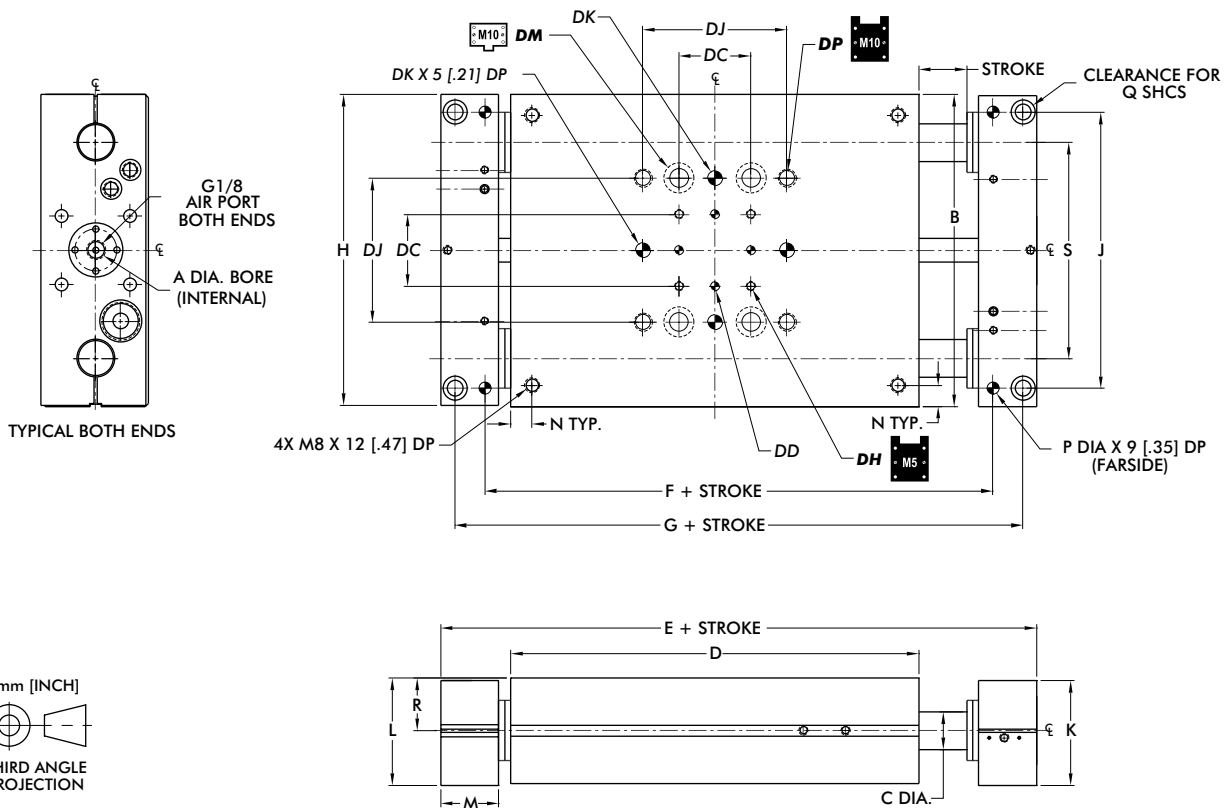

DIRECTCONNECT™ Mounting Pattern Dimensions (all sizes)						
DC	DD	DH	DJ	DK	DM	DP
38.1 [1.500]	5 mm H7 x 6 DP	M5 x 8.5 DP	76.2 [3.000]	8 mm H7 x 9.4 DP	CLR & C'BORE FOR M10	M10 x 12 DP

Model	Bore Ø	Body Size	Shaft Ø	Basic Unit Dimensions													
				A	B	C	D	E	F	G	H	J	K	L	M	N	P
DLB-20M	38 [1.5]	165.1 [6.50]	20 [0.787]	215.9 [8.50]	290.1 [11.42]	243.46 [9.5850]	275.2 [10.836]	164.6 [6.480]	146.05 [5.7500]	55.4 [2.180]	56.8 [2.236]	30.7 [1.210]	11.1 [0.438]	6.00 [0.2505]	M8	27.94 [1.100]	114.30 [4.500]
DLB-25M		190.5 [7.50]	25 [0.984]	241.3 [9.50]	326.1 [12.84]	272.59 [10.7320]	307.5 [12.108]	190.0 [7.480]	171.45 [6.7500]	55.4 [2.180]		36.1 [1.420]		8.00 [0.3130]	M10		133.35 [5.250]

Dimensions in mm [in]

Loading Information

- F**=Externally applied force
- W**=Weight of payload
- F+W**=Total force
- M**=Maximum moment

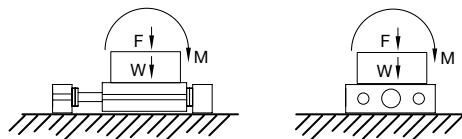

	20	25
Maximum Payload (W) horizontal motion using Shock Absorbers	27.2 kg [60 lbs]	45.3 kg [100 lbs]
Maximum Payload (W) vertical motion using Shock Absorbers	13.6 kg [30 lbs]	22.0 kg [50 lbs]
Maximum Payload (W) horizontal motion using Urethane Bumpers	9.1 kg [20 lbs]	11.3 kg [25 lbs]
Maximum Total Applied Load + Payload (F+W)	444 N [100 lbs]	667 N [150 lbs]
Total Maximum Moment about any Axis (M)	67.7 Nm [600 in-lbs]	[1200 in-lbs]

Shock Absorbers and Flow Controls are recommended for all applications

DLB SERIES - EXTERNAL AIR CYLINDER

External Air Cylinder Linear Base Slides | Features and Benefits | How To Order

Features:

- Bearing system for smooth operation
- Rugged design produces very reliable long life operation
- Replaceable air cylinder with adjustable cushions
- Urethane bumpers, hardened pads, oil wick
- Optional telescopic airlines transfers air to tooling
- DIRECTCONNECT™ mounting pattern
- Corrosion resistant shafting for corrosive environments
- Position sensing using inductive or magneto resistive sensors

Applications:

- Machining and automation applications
- Harsh environment pick-and-place applications
- OEM Part Transfers applications
- X Y Cartesian Table Applications

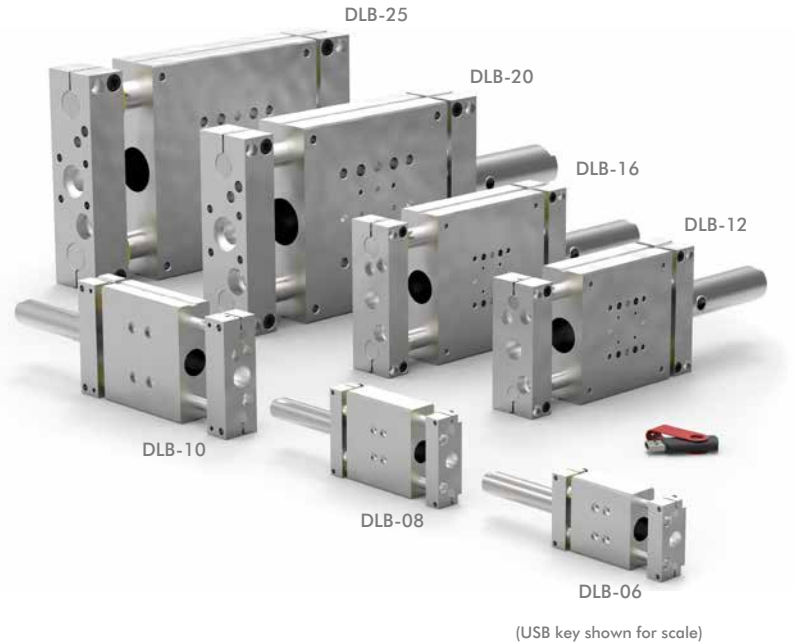

How To Order

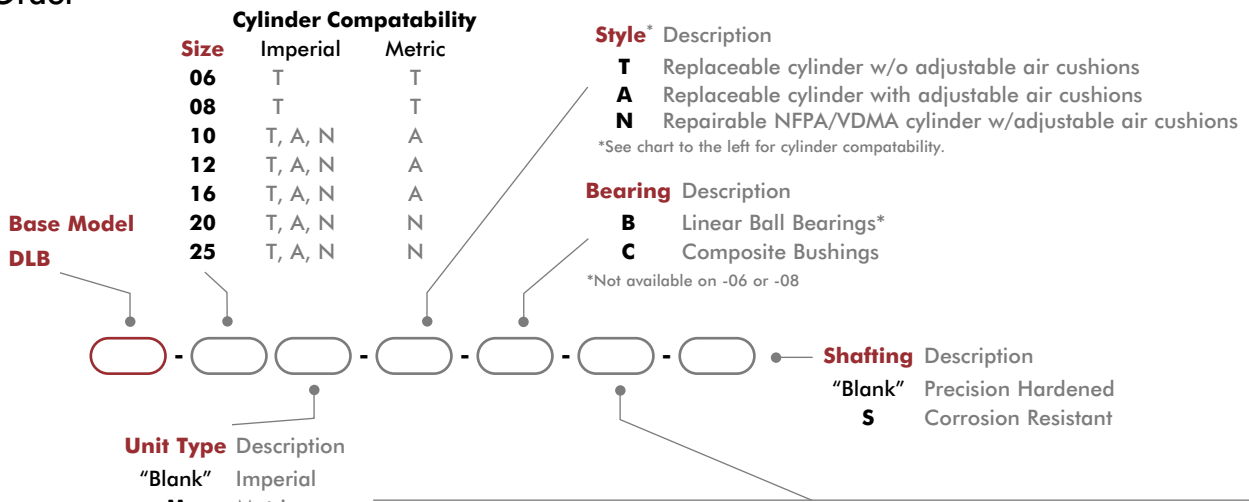

Size	Style	Stroke* Imperial (in)
DLT-06	T	.5, 1, 1.5, 2, 2.5, 3, 4, 5, 6
DLT-08	T	.5, 1, 1.5, 2, 2.5, 3, 4, 5, 6, 7, 8
DLT-10	T, A, N	1-12 @ 1" increments
DLT-12	T, A, N	1-16 @ 1" increments
DLT-16	T, A, N	1-20 @ 1" increments
DLT-20	T, A, N	1-24 @ 1" increments
DLT-25	T, A, N	1-26 @ 1" increments

Size	Style	Stroke* Metric (mm)
DLT-06M	T	10, 25, 40, 50, 75, 100, 125, 160
DLT-08M	T	10, 25, 40, 50, 75, 100, 125, 160, 175, 200
DLT-10M	A	25, 50, 80, 100, 125, 160, 200, 250, 300
DLT-12M	A	25, 50, 80, 100, 125, 160, 200, 250, 300, 320, 360, 400
DLT-16M	A	25, 50, 80, 100, 125, 160, 200, 250, 300, 320, 360, 400, 500
DLT-20M	N	25, 50, 80, 100, 125, 160, 200, 250, 300, 320, 360, 400, 500
DLT-25M	N	25, 50, 80, 100, 125, 160, 200, 250, 300, 320, 360, 400, 500

*Custom strokes available. Consult factory.

DLB SERIES - EXTERNAL AIR CYLINDER

External Air Cylinder Linear Base Slides | Accessories

Shock/Stop Accessories	Model Sizes	Style	Part Number	Qty/Unit
Shock Absorber	06, 08	All	SHOK-030	1-2
	10		SHOK-028	
	12, 16,		SHOK-010	
	20, 25		SHOK-029	
Adjustable Hard Stop	06, 08		DLT-0623	
	10, 12, 16, 20, 25	DLT-1023		

Sensor Accessories	Model Sizes	Style	Part Number	Qty/Unit
PNP Inductive Sensor with Quick Disconnect*	All Models	All	OISP-011	1-2
NPN Inductive Sensor with Quick Disconnect*			OISN-011	
PNP Magneto Resistive Sensor w/Qk Disconnect*	06, 08, 10, 12, 16	T, A, N	OHSP-005	
NPN Magneto Resistive Sensor w/Quick Disconnect*			OHSN-005	
PNP Magneto Resistive Sensor w/Qk Disconnect*	20, 25	N	OHSP-020	
NPN Magneto Resistive Sensor w/Qk Disconnect*			OHSN-020	
Quick Disconnect 2 Meter Cable Length*	All Models	All	CABL-010	
Quick Disconnect 5 Meter Cable Length*			CABL-013	
Cable Extension Cord 1M Length*	All Models	All	CABL-015	
Cable Extension Cord 2M Length*			CABL-016	

Pneumatic Accessories	Model Sizes	Style	Part Number	Qty/Unit
1/8 NPT Telescopic Airlines (up to 6")	10, 12, 16	All	OTAL-039	1-4
1/8 NPT Telescopic Airlines (up to 12")	10, 12, 16		OTAL-040	
1/8 NPT Telescopic Airlines (up to 18")	10, 12, 16, 20, 25		OTAL-041	
1/8 NPT Telescopic Airlines (up to 24")	20, 25		OTAL-042	
#10-32 NPT Adjustable Flow Control	06, 08		VLVF-007	1-2
1/8 NPT Adjustable Flow Control	10, 12, 16, 20, 25		VLVF-004	
G1/8 Telescopic Airlines (up to 160mm)	10, 12, 16		OTAL-045	1-4
G1/8 Telescopic Airlines (up to 300mm)	10, 12, 16		OTAL-046	
G1/8 Telescopic Airlines (up to 450mm)	10, 12, 16, 20, 25		OTAL-047	
G1/8 Telescopic Airlines (up to 600mm)	20, 25		OTAL-048	
G1/8 Adjustable Flow Control	10, 12, 16, 20, 25		VLVF-005	1-2
G1/8 Male to 1/8 NPT Adapter	20, 25		PLFT-025	

*Sensor and cable sold separately.

See page GR-LIN-35 for Accessory Mounting Technical Data.

DLB SERIES - EXTERNAL AIR CYLINDER

External Air Cylinder Linear Base Slides | Technical Specifications

Specifications	Units	06	08	10	12
Max. Air Pressure	bar [psi]	7 [100]			
Thrust Force @ 5.5 bar [80psi]	N [lbs]	89 [20]		145 [31]	289 [65]
Weight (basic unit)	kg [lb]	0.15 [0.34]	0.31 [0.69]	0.90 [1.98]	1.66 [3.73]
Additional Weight per Stroke	g/mm [lbs/in]	0.88 [0.05]	1.23 [0.07]	1.4 [0.09]	2.9 [0.16]
Cylinder Bore Ø	mm [in]	16 [0.563]		20 [0.75]	25 [1.00]
Shaft Ø	mm [in]	6 [0.236]	8 [0.315]	9.5 [0.375]	12 [0.472]
Maximum Moment Load	N-m [in-lbs]	1.7 [15]	3.4 [30]	8.4 [75]	16.9 [150]

Specifications	Units	16	20	25
Max. Air Pressure	bar [psi]	7 [100]		
Thrust Force @ 5.5 bar [80psi]	N [lbs]	289 [65]	578 [130]	578 [130]
Weight (basic unit)	kg [lb]	2.3 [5.03]	5.9 [12.9]	8.3 [18.0]
Additional Weight per Stroke	g/mm [lbs/in]	4.2 [0.23]	9.5 [0.53]	12.1 [0.68]
Cylinder Bore Ø	mm [in]	25 [1.00]	32 [1.25]	32 [1.25]
Shaft Ø	mm [in]	16 [0.630]	20 [0.787]	25 [0.984]
Maximum Moment Load	N-m [in-lbs]	33.9 [300]	67.8 [600]	135 [1200]



External Air Cylinder Linear Base Slides | Dimensions and Technical Specifications

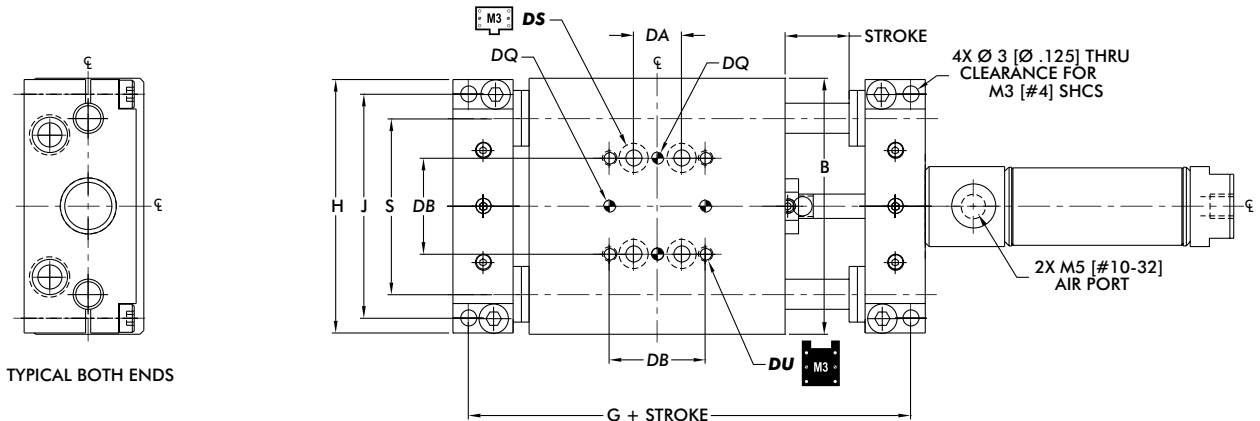

TYPICAL BOTH ENDS

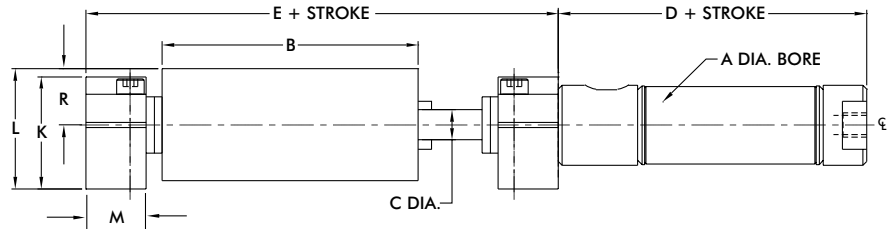
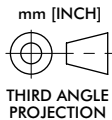

DIRECTCONNECT™ Mounting Pattern Dimensions (all sizes)				
DA	DB	DQ	DS	DU
9.5 [0.375]	19.1 [0.750]	3H7 x 2 DP [0.0940 x 0.078 DP]	CLR & C'BORE FOR M3 [CLR & C'BORE FOR #4]	M3 x 6 DP [#4-40 x .25 DP]

Model	Bore Ø			Body Size			Shaft Ø			Basic Unit Dimensions						
	A	B	C	D	E	G	H	J	K	L	M	R	S			
DLB-06	16 [0.563]	50.8 [2.00]	6.0 [0.236]	48.4 [1.91]	81.0 [3.19]	75.1 [2.956]	50.3 [1.980]	44.4 [1.750]	22.2 [0.875]	23.7 [0.936]	11.9 [0.470]	11.13 [0.438]	34.93 [1.375]			
DLB-08		63.5 [2.50]	8.0 [0.315]		93.7 [3.69]	87.8 [3.456]	62.7 [2.470]	57.1 [2.250]					44.45 [1.750]			

Dimensions in mm [in]

Loading Information

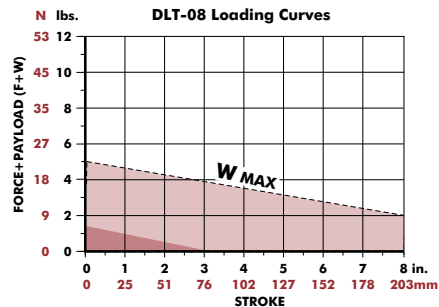
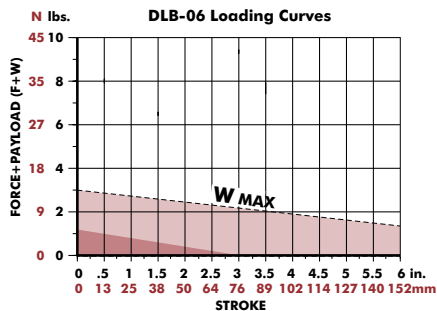

Shock Absorbers and Flow Controls are recommended for all applications

F=Externally applied force
W=Weight of payload
F+W=Total force

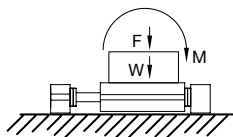

(W) in this range use **Single Shock** in both directions

(W) in this range use **Bumpers or Cushioned Cylinder**

Shaded shock absorption ranges of horizontal payload (W) @ 80psi, flow controls fully open. For vertical applications do not exceed 1/2 of the recommended payload due to the additional acceleration effect of gravity.

DLB-10/12/16-T, A

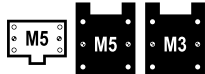

External Air Cylinder Linear Base Slides | Dimensions and Technical Specifications

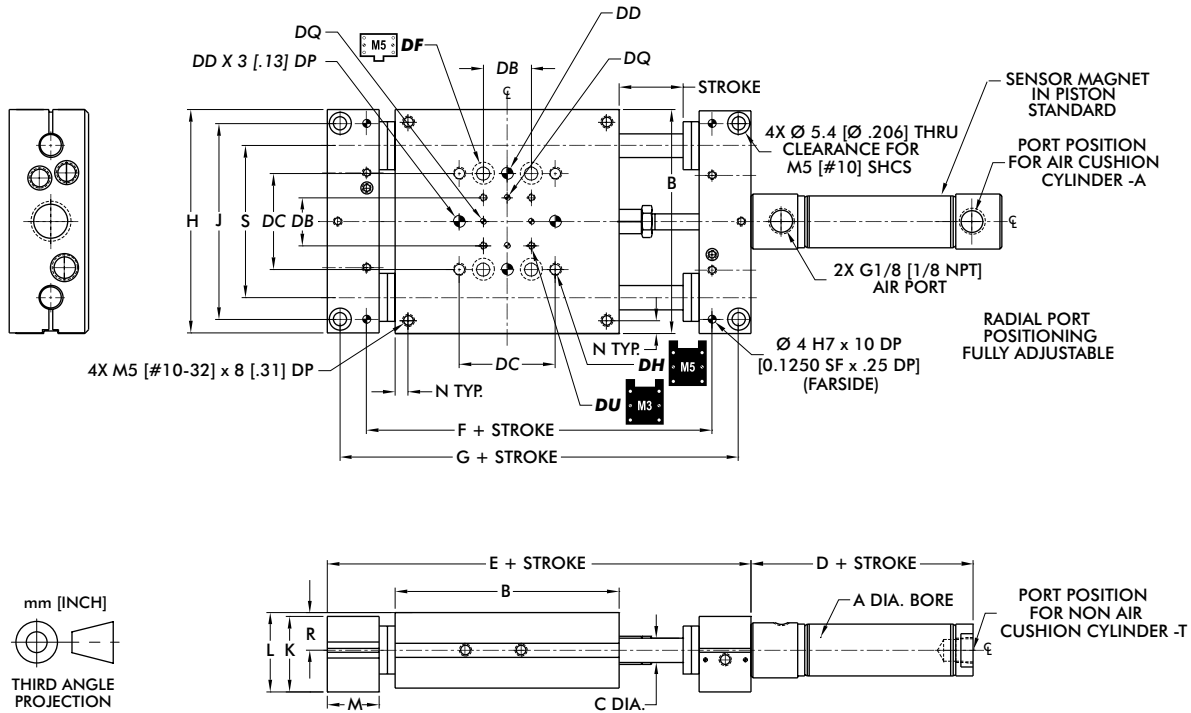

DIRECTCONNECT™ Mounting Pattern Dimensions (all sizes)						
DB	DC	DD	DF	DH	DQ	DU
19.1 [0.750]	38.1 [1.500]	5mm H7 x 6 DP [0.1880 x 0.25 DP]	CLR & C'BORE FOR M5 [CLR & C'BORE FOR #10]	M5 x 8.5 DP [#10-32 x 0.34 DP]	3H7 x 2 DP [0.0940 x 0.078 DP]	M3 x 6 DP [#4-40 x 0.25 DP]

Model	Bore Ø Body Size Shaft Ø			Basic Unit Dimensions											
	A	B	C	D	E	F	G	H	J	K	L	M	N	R	S
DLB-10	20 [0.75]	88.9 [3.50]	9.5 [0.375]	88.0 [2.91]	149.4 [5.63]	118.05 [4.3975]	139.1 [5.228]	88.5 [3.485]	77.7 [3.060]	29.9 [1.178]	31.6 [1.245]		N/A	15.09 [0.594]	60.33 [2.375]
DLB-12	25 [1 1/16]	101.6 [4.00]	12 [0.472]	91.5 [2.88]	162.1 [6.13]	130.75 [4.8975]	151.8 [5.728]	101.2 [3.985]	88.9 [3.500]	41.0 [1.615]	42.1 [1.657]	20.7 [0.813]	9.5 [0.375]	20.65 [0.813]	69.85 [2.750]
DLB-16		120.7 [4.75]	16 [0.630]		181.1 [6.88]	149.80 [5.6475]	170.9 [6.478]	120.3 [4.735]	107.9 [4.250]						82.55 [3.250]

Dimensions in mm [in]

Loading Information

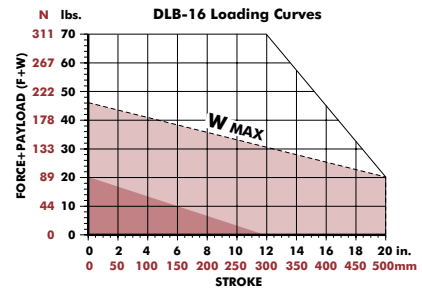
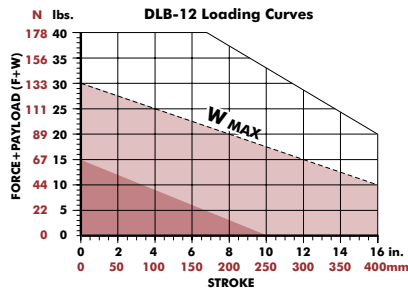
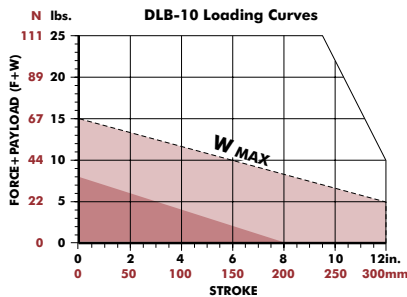

Shock Absorbers and Flow Controls are recommended for all applications

F=Externally applied force
W=Weight of payload
F+W=Total force

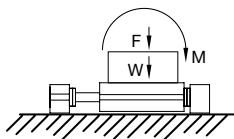

(W) in this range use **Single Shock** in both directions

(W) in this range use **Bumpers or Cushioned Cylinder**

Shaded shock absorption ranges of horizontal payload (W) @ 80psi, flow controls fully open. For vertical applications do not exceed 1/2 of the recommended payload due to the additional acceleration effect of gravity.

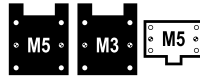

External Air Cylinder Linear Base Slides | Dimensions and Technical Specifications

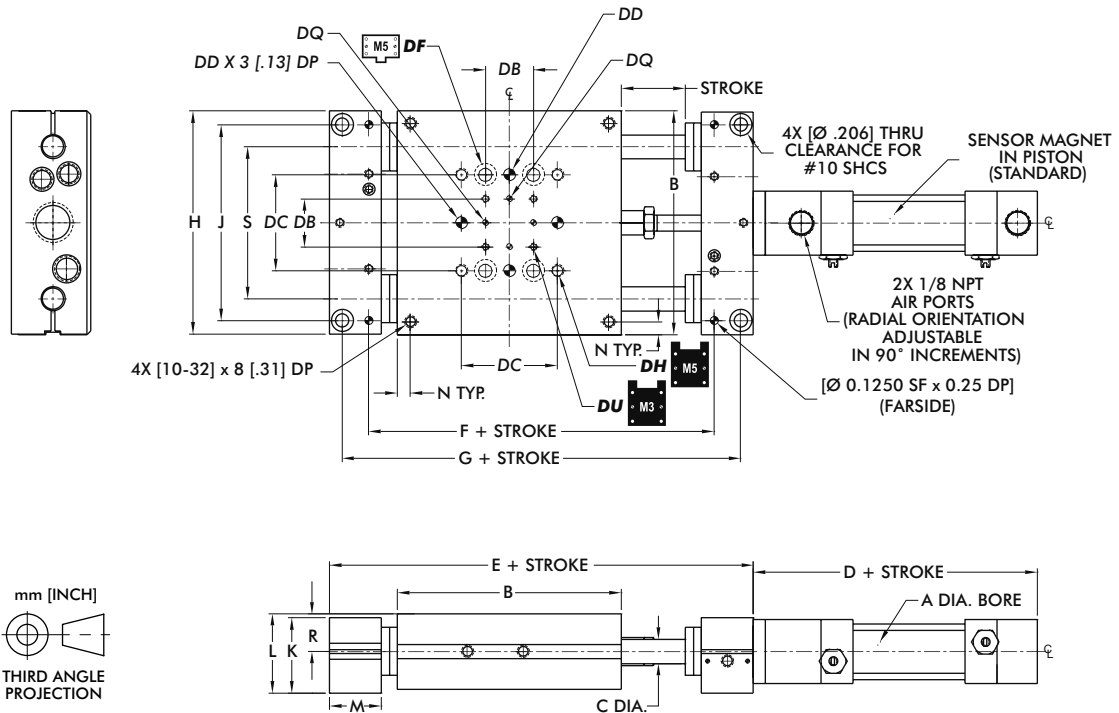

DIRECTCONNECT™ Mounting Pattern Dimensions (all sizes)

DB	DC	DD	DF	DH	DQ	DU
19.1 [0.750]	38.1 [1.500]	[0.1880 x 0.25 DP]	[CLR & C'BORE FOR #10]	[#10-32 x 0.34 DP]	[0.0940 x 0.078 DP]	[#4-40 x .25 DP]

Model	Bore Ø Body Size Shaft Ø			Basic Unit Dimensions											
	A	B	C	D	E	F	G	H	J	K	L	M	N	R	S
DLB-10	20 [0.75]	88.9 [3.50]	9.5 [0.375]		149.4 [5.63]	118.05 [4.3975]	139.1 [5.228]	88.5 [3.485]	77.7 [3.060]	29.9 [1.178]	31.6 [1.245]		N/A	15.09 [0.594]	60.33 [2.375]
DLB-12	25 [1 1/8]	101.6 [4.00]	12 [0.472]	87.4 [3.44]	162.1 [6.13]	130.75 [4.8975]	151.8 [5.728]	101.2 [3.985]	88.9 [3.500]	41.0 [1.615]	42.1 [1.657]	20.7 [0.813]	9.5 [0.375]	20.65 [0.813]	69.85 [2.750]
DLB-16		120.7 [4.75]	16 [0.630]		181.1 [6.88]	149.80 [5.6475]	170.9 [6.478]	120.3 [4.735]	107.9 [4.250]						

Dimensions in mm [in]

Loading Information

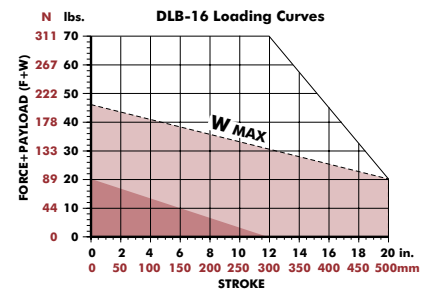
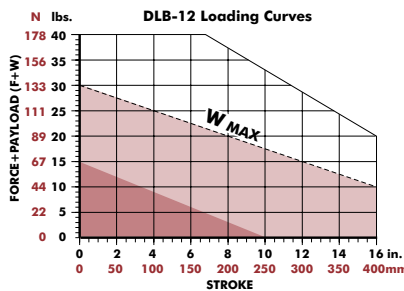
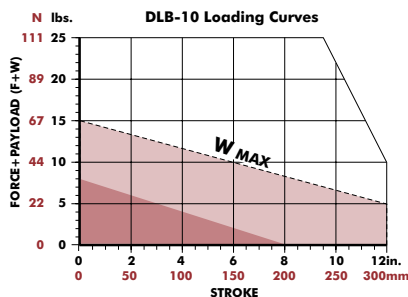

Shock Absorbers and Flow Controls are recommended for all applications

F=Externally applied force
W=Weight of payload
F+W=Total force

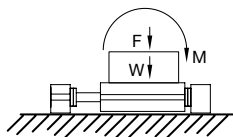

(W) in this range use **Single Shock** in both directions

(W) in this range use **Bumpers or Cushioned Cylinder**

Shaded shock absorption ranges of horizontal payload (W) @ 80psi, flow controls fully open. For vertical applications do not exceed 1/2 of the recommended payload due to the additional acceleration effect of gravity.

DLB-20/25-T, A



External Air Cylinder Linear Base Slides | Dimensions and Technical Specifications

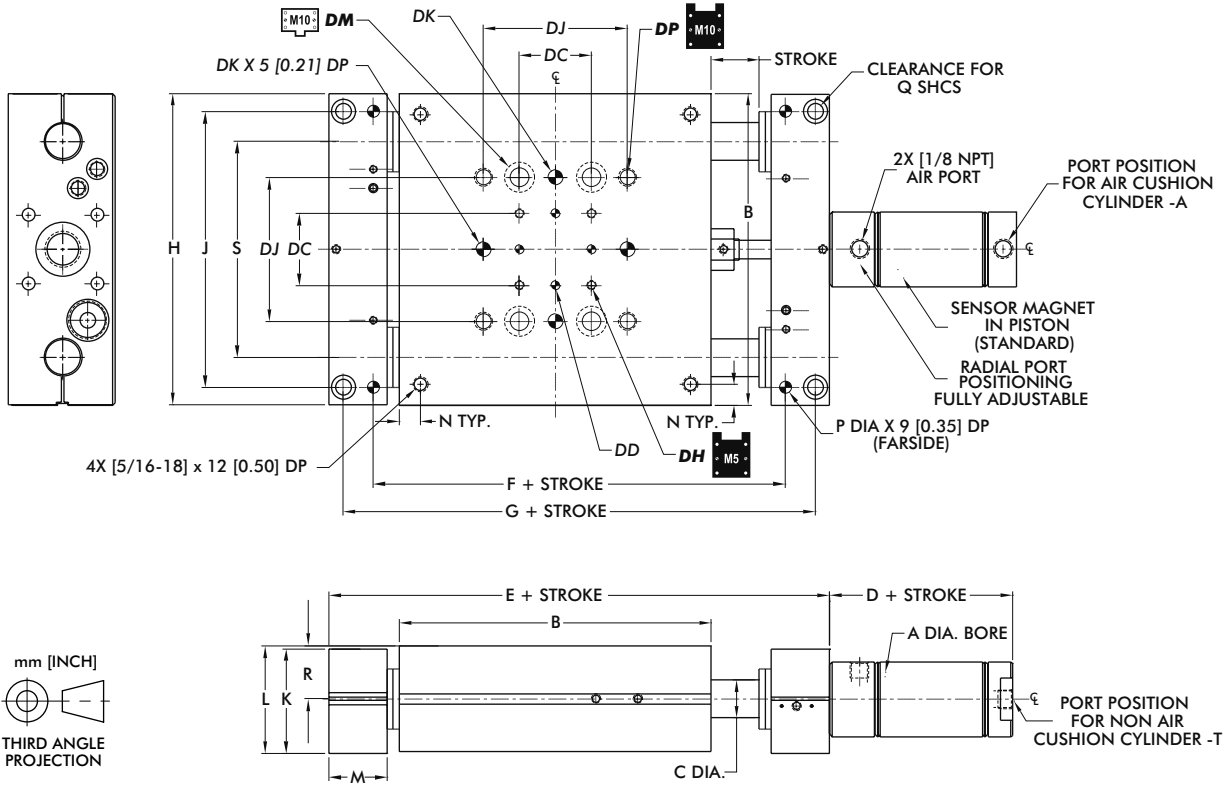

DIRECTCONNECT™ Mounting Pattern Dimensions (all sizes)						
DC	DD	DH	DJ	DK	DM	DP
38.1 [1.500]	[0.1880 x 0.25 DP]	[#10-32 x 0.38 DP]	76.2 [3.000]	[0.3130 x 0.37 DP]	[CLR & C'BORE FOR 3/8]	[3/8-16 x .50 DP]

Model	Bore Ø Body Ø Shaft Ø			Basic Unit Dimensions													
	A	B	C	D	E	F	G	H	J	K	L	M	N	P	Q	R	S
DLB-20	38.1 [1 1/2]	165.1 [6.50]	20 [0.787]	76.2 [3.00]	239.3 [9.42]	192.66 [7.5850]	224.4 [8.836]	164.6 [6.480]	146.05 [5.7500]	55.4 [2.180]	56.8 [2.236]	30.7 [1.210]	11.1 [0.438]	6.00 [0.2505]	M8	27.94 [1.100]	114.30 [4.500]
DLB-25		190.5 [7.50]	25 [0.984]		275.3 [10.84]	221.79 [8.7320]	256.7 [10.108]	190.0 [7.480]	171.45 [6.7500]			36.1 [1.420]		8.00 [0.3130]	M10		113.35 [5.250]

Dimensions in mm [in]

Loading Information

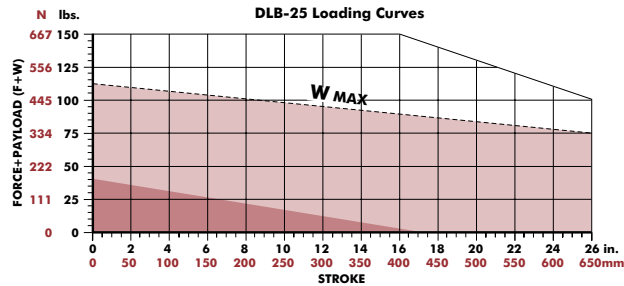
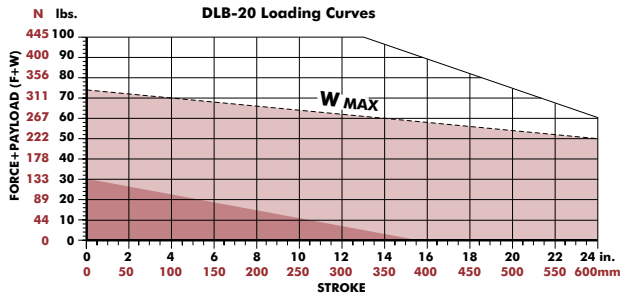

Shock Absorbers and Flow Controls are recommended for all applications

F=Externally applied force
W=Weight of payload
F+W=Total force

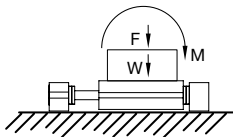

(W) in this range use **Single Shock** in both directions

(W) in this range use **Bumpers or Cushioned Cylinder**

Shaded shock absorption ranges of horizontal payload (W) @ 80psi, flow controls fully open. For vertical applications do not exceed 1/2 of the recommended payload due to the additional acceleration effect of gravity.

External Air Cylinder Linear Base Slides | Dimensions and Technical Specifications

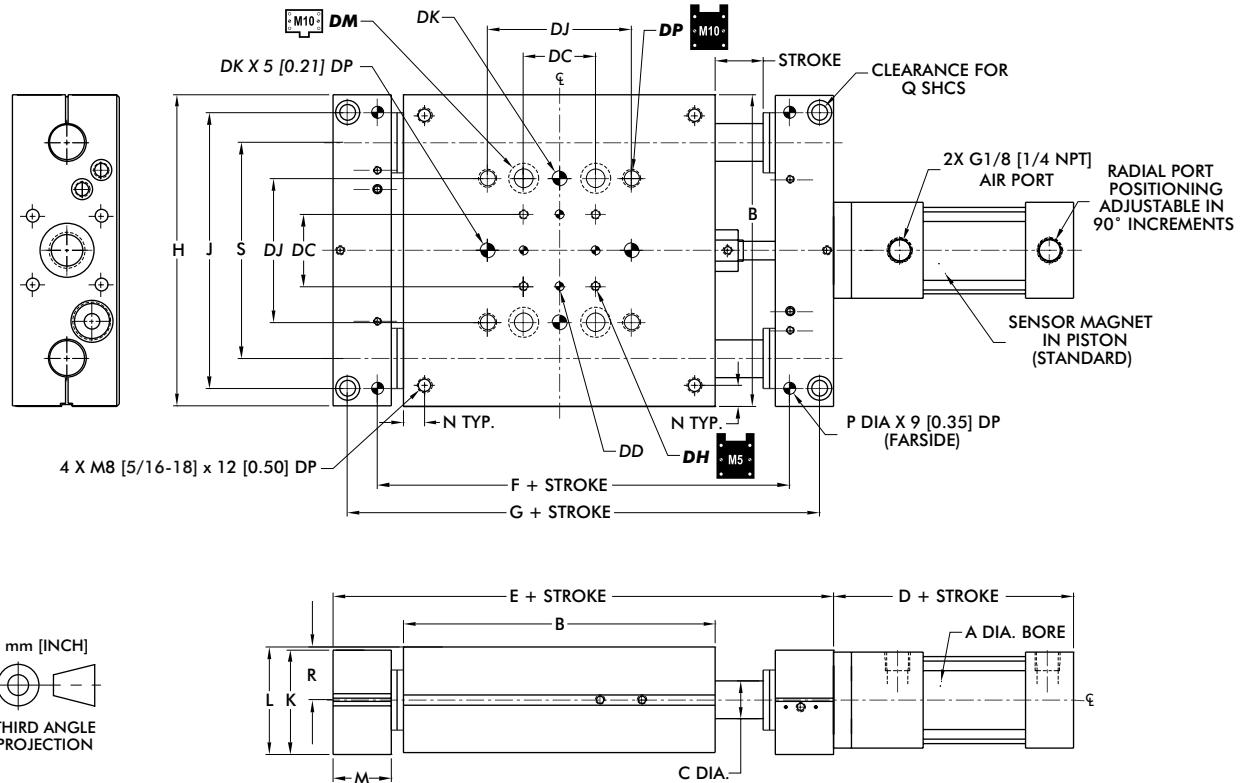

DIRECTCONNECT™ Mounting Pattern Dimensions (all sizes)

DC	DD	DH	DJ	DK	DM	DP
38.1 [1.500]	5 mm H7 x 6 DP [0.1880 x 0.25 DP]	M5 x 9 DP [#10-32 x 0.38 DP]	76.2 [3.000]	8 mm H7 x 9.4 DP [0.3130 x 0.37 DP]	CLR & C'BORE FOR M10 [CLR & C'BORE FOR 3/8]	M10 x 12 DP [3/8-16 x 0.50 DP]

Model	Bore Ø Body Ø Shaft Ø			Basic Unit Dimensions													
	A	B	C	D	E	F	G	H	J	K	L	M	N	P	Q	R	S
DLB-20	38.1 [1 1/2]	165.1 [6.50]	20 [0.787]	92.2 [3.63]	239.3 [9.42]	192.66 [7.5850]	224.4 [8.836]	164.6 [6.480]	146.05 [5.7500]	55.4 [2.180]	56.8 [2.236]	30.7 [1.210]	11.1 [0.438]	6.00 [0.2505]	M8	27.94 [1.100]	114.30 [4.500]
DLB-25		190.5 [7.50]	25 [0.984]		275.3 [10.84]	221.79 [8.7320]	256.7 [10.108]	190.0 [7.480]	171.45 [6.7500]			36.1 [1.420]		8.00 [0.3130]	M10		113.35 [5.250]

Dimensions in mm [in]

Loading Information

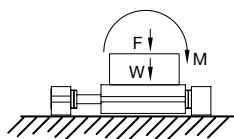
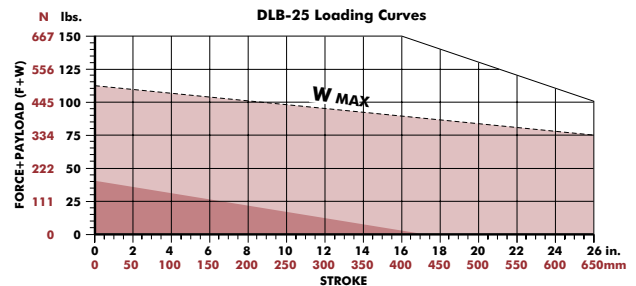
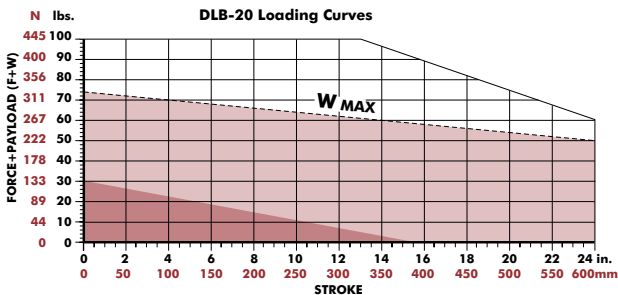

F=Externally applied force
W=Weight of payload
F+W=Total force

Shock Absorbers and Flow Controls are recommended for all applications

(W) in this range use **Single Shock** in both directions

(W) in this range use **Bumpers or Cushioned Cylinder**

Shaded shock absorption ranges of horizontal payload (W) @ 80psi, flow controls fully open. For vertical applications do not exceed 1/2 of the recommended payload due to the additional acceleration effect of gravity.

DLT SERIES - INTERNAL AIR CYLINDER

Internal Air Cylinder Linear Thruster Slides | Features and Benefits | How To Order

Features:

- 3 Models: **-B** block style, **-E** short body & **-L** long body
- Bearing system for smooth operation
- Rugged design produces very reliable long life operation
- Internal air cylinder for space-limited applications
- Urethane bumpers, hardened pads, oil wick
- Optional telescopic airlines transfers air to tooling
- DIRECTCONNECT™ mounting pattern
- Corrosion resistant shafting for corrosive environments
- Position sensing using inductive or magneto resistive sensors
- Viton® seals for high temperature applications

Applications:

- Machining, harsh environment, pick-and-place automation applications
- Lift table applications

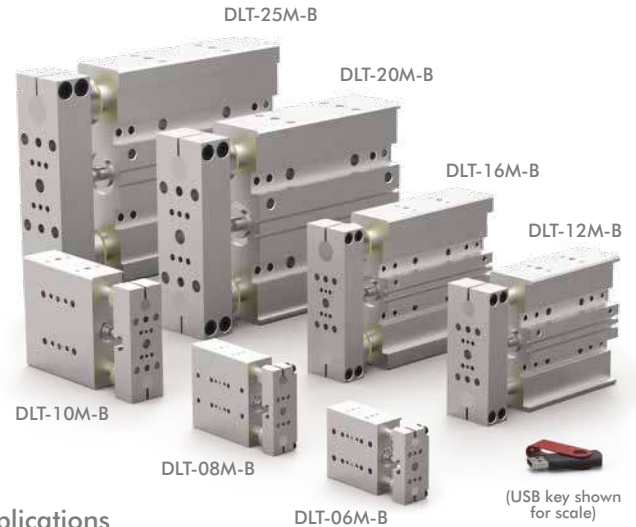

How To Order

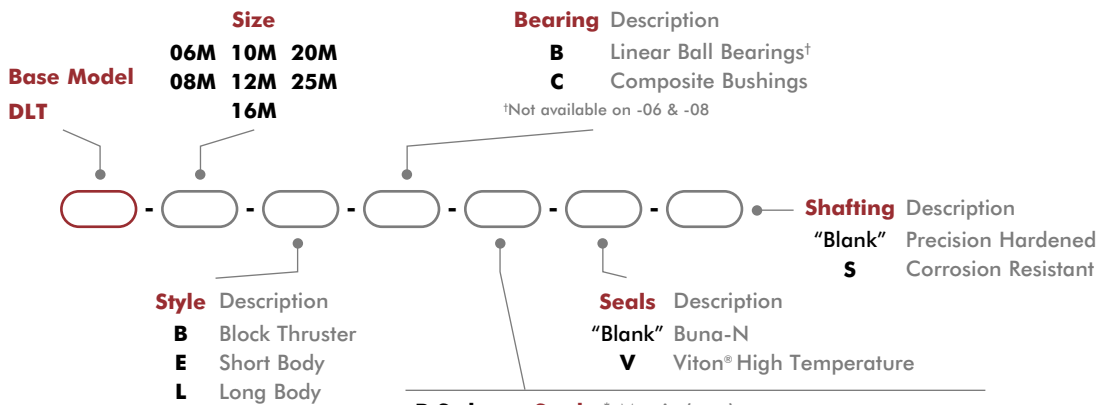

-B Style	Stroke* Metric (mm)
DLT-06M-B	6, 12, 25, 30
DLT-08M-B	6, 12, 25, 30, 40, 44
DLT-10M-B	12, 25, 40, 50
DLT-12M-B	12, 25, 40, 50
DLT-16M-B	12, 25, 40, 50, 65, 75
DLT-20M-B	12, 25, 40, 50, 65, 75, 85, 100
DLT-25M-B	12, 25, 40, 50, 65, 75, 85, 100, 115, 125
-E Style	Stroke* Metric (mm)
DLT-06M-E	6, 12, 25, 30
DLT-08M-E	6, 12, 25, 40, 44
DLT-10M-E	25, 50
DLT-12M-E	25, 50
DLT-16M-E	25, 50, 75
DLT-20M-E	25, 50, 75, 100
DLT-25M-E	25, 50, 75, 100, 125
-L Style	Stroke* Metric (mm)
DLT-06M-L	12, 25, 40, 50, 65, 75
DLT-08M-L	12, 25, 40, 50, 65, 75, 85
DLT-10M-L	25, 50, 80, 100
DLT-12M-L	25, 50, 80, 100, 125
DLT-16M-L	25, 50, 80, 100, 125, 150
DLT-20M-L	25, 50, 75, 100, 125, 160
DLT-25M-L	25, 50, 75, 100, 125, 160, 175

*Custom strokes available. Consult factory.

DLT SERIES - INTERNAL AIR CYLINDER

Internal Air Cylinder Linear Thruster Slides | Accessories

Shock/Stop & Mounting Accessories	Model Numbers	Style	Part Number	Qty/Unit
Universal Mounting Kit (Stop/Shock)	06	All	OSAK-069	1-2 on -B 1-4 on -E, -L
	08		OSAK-070	
Universal Mounting Kit (Stop/Shock/Sensor)	10		OSAK-055	
	12		OSAK-057	
	16		OSAK-059	
	20		OSAK-061	
	25		OSAK-063	
Shock Absorber	06, 08		SHOK-030	
	10		SHOK-028	
	12, 16,		SHOK-010	
	20, 25	SHOK-029		
Adjustable Hard Stop	06, 08	DLT-0623		
	10, 12, 16, 20, 25	DLT-1023		
Urethane Bumper/Stop Collar Kit	06	E, L	OSAK-067	1
	08		OSAK-068	
	10		OSAK-065	
	12		OSAK-066	
	16		OSAK-060	
	20		OSAK-062	
Base Flange Kit	25	OSAK-064		
	See Datasheet	B	--	

Sensor Accessories	Model Numbers	Style	Part Number	Qty/Unit	
Inductive Sensor Mounting Kit	06	All	OSMK-076	1 on -B 1-2 on -E, -L	
	08		OSMK-077		
PNP Inductive Sensor with Quick Disconnect*	06, 08		OISP-014		
NPN Inductive Sensor with Quick Disconnect*			OISN-014		
PNP Inductive Sensor with Quick Disconnect*	10, 12, 16, 20, 25		OISP-011		
NPN Inductive Sensor with Quick Disconnect*			OISN-011		
PNP Magneto Resistive with Quick Disconnect*	All Models		OHSP-017		1-2
NPN Magneto Resistive with Quick Disconnect*			OHSN-017		
Quick Disconnect 2 Meter Cable Length*	All Models		CABL-010		
Quick Disconnect 5 Meter Cable Length*			CABL-013		

*Sensor and cable sold separately.

Pneumatic Accessories	Model Numbers	Style	Part Number	Qty/Unit
G1/8 Telescopic Airlines (up to 50mm)	10, 12, 16	B, E	OTAL-043	1-4
G1/8 Telescopic Airlines (up to 80mm)		B, E, L	OTAL-044	
G1/8 Telescopic Airlines (up to 100mm)	20, 25	B, E	OTAL-051	
G1/8 Telescopic Airlines (up to 125mm)			OTAL-052	
G1/8 Telescopic Airlines (up to 160mm)	10, 12, 16	L	OTAL-045	
G1/8 Telescopic Airlines (up to 300mm)	20, 25		OTAL-046	
M5 Adjustable Flow Control	06, 08, 10, 12, 16	All	VLVF-008	1-2
G1/8 Adjustable Flow Control	20, 25		VLVF-005	
Seal Kits	See Datasheets			1

See page GR-LIN-36 for Accessory Mounting Technical Data.

DLT SERIES - INTERNAL AIR CYLINDER

Internal Air Cylinder Linear Thruster Slides | Technical Specifications

Specifications	Units	06-B, E	06-L	08-B, E	08-L	10-B, E	10-L	12-B, E	12-L
Max. Air Pressure	bar [psi]	7 [100]							
Thrust Force @ 5.5 bar [80psi]	N [lbs]	89 [20]				155 [35]		275 [62]	
Weight -B (basic unit)	kg [lb]	0.15 [0.34]	--	0.30 [0.65]	--	0.82 [1.81]	--	1.31 [2.88]	--
Weight -E, L (basic unit)	kg [lb]		0.28 [0.61]		0.44 [0.96]	0.84 [1.87]	0.88 [1.95]	1.35 [2.98]	1.46 [3.21]
Cylinder Bore Ø	mm [in]	14.3 [0.563]				19 [0.75]		25 [1.0]	
Shaft Ø	mm [in]	6 [0.236]		8 [0.315]		9.5 [0.375]		12 [0.472]	
Max (M) Vertical Motion	Nm [in-lbs]	0.6 [5]		1.1 [10]		2.8 [25]		5.6 [50]	

Specifications	Units	16-B, E	16-L	20-B, E	20-L	25-B, E	25-L
Max. Air Pressure	bar [psi]	7 [100]					
Thrust Force @ 5.5 bar [80psi]	N [lbs]	275 [62]		622 [140]			
Weight -B (basic unit)	kg [lb]	1.99 [4.38]	--	5.1 [11.6]	--	7.2 [15.7]	--
Weight -E, L (basic unit)	kg [lb]	2.07 [4.56]	2.03 [4.81]	5.2 [11.6]	5.5 [12.0]	7.4 [16.4]	7.9 [17.4]
Cylinder Bore Ø	mm [in]	25 [1.0]		38 [1.5]			
Shaft Ø	mm [in]	16 [0.630]		20 [0.787]		25 [0.984]	
Max (M) Vertical Motion	Nm [in-lbs]	11.3 [100]		28.2 [250]		56.4 [500]	

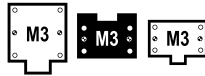

Internal Air Cylinder Linear Thruster Slides | Dimensions and Technical Specifications

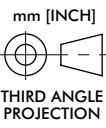
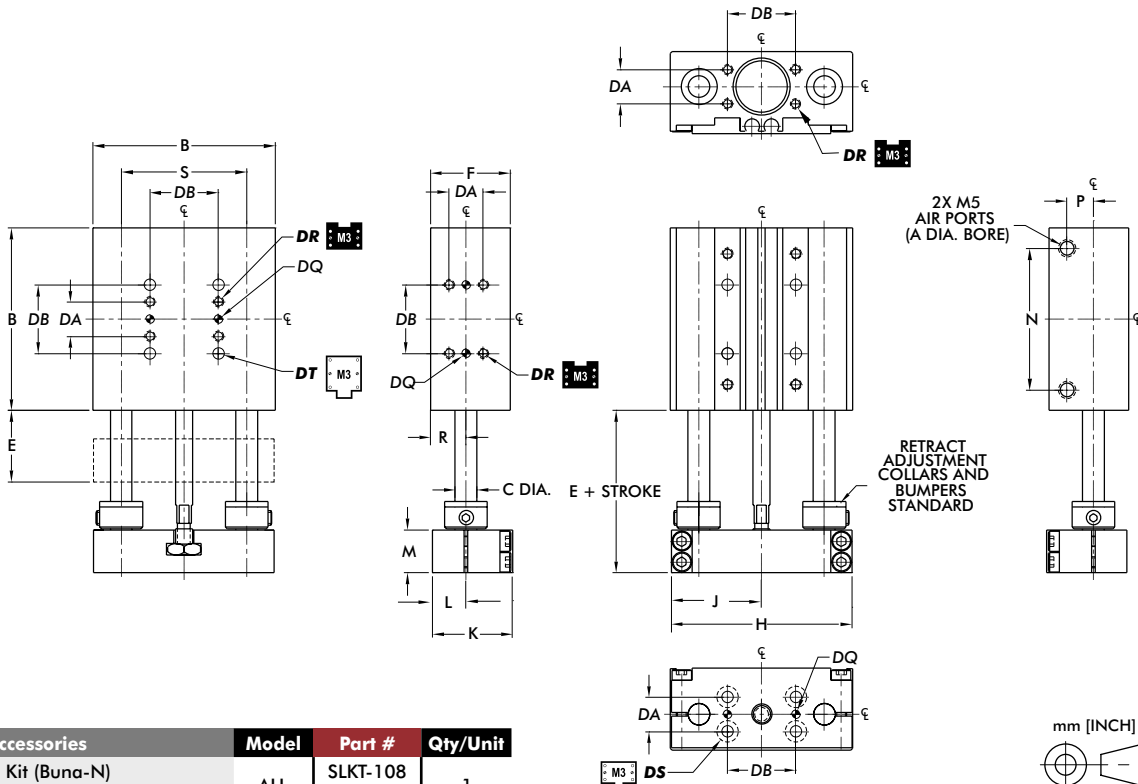

Pneumatic Accessories	Model	Part #	Qty/Unit
Cylinder Seal Kit (Buna-N)	ALL	SLKT-108	1
Cylinder Seal Kit (Viton®)		SLKT-108V	1
Base Flange Kit	-06	ODLT-015	1
(See page GR-LIN-36 for information)	-08	ODLT-016	1

DIRECCONNECT™ Mounting Pattern Dimensions (all sizes)					
DA	DB	DQ	DR	DS	DT
9.5 [0.375]	19.1 [0.750]	3H7 x 2 DP	M3 x 6 DP	CLR & C'BORE FOR M3	CLR & C'BORE FOR M3

Model	Bore Ø	Body Size		Shaft Ø	Basic Unit Dimensions									
		A	B		C	E	F	H	J	K	L	M	N	P
DLT-06M	14 [0.563]	50.8 [2.00]	6.0 [0.236]	19.9 [0.783]	22.4 [0.88]	50.3 [1.980]	25.1 [0.990]	22.2 [0.875]	9.3 [0.365]	11.9 [0.470]	39.4 [1.55]	7.4 [0.29]	9.9 [0.390]	34.93 [1.375]
DLT-08M		63.5 [2.50]	8.0 [0.315]			62.7 [2.470]	31.0 [1.235]				52.1 [2.05]			44.45 [1.75]

Dimensions in mm [in]

Loading Information

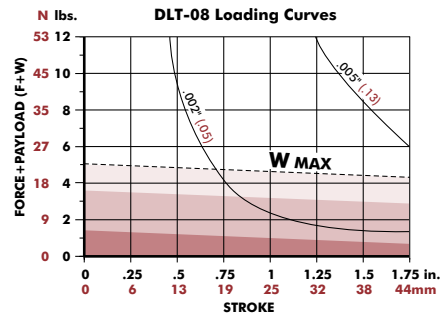
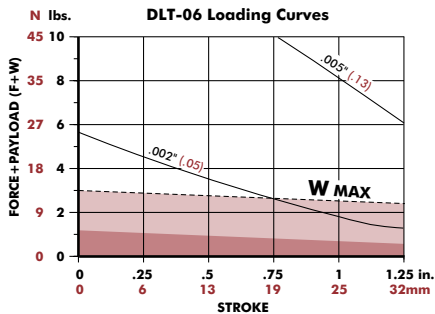

F=Externally applied force

W=Weight of payload

F+W=Total force

M=Maximum moment (in-lb. or N-m)

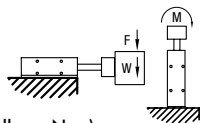

Shock Absorbers and Flow Controls are recommended for all applications

Use **Double Shocks** in both directions

Use **Single Shock** in both directions

Use **Bumpers or Cushioned Cylinder**

Shaded shock absorption ranges of horizontal payload (W) @ 80psi, flow controls fully open. For vertical applications do not exceed 1/2 of the recommended payload due to the additional acceleration effect of gravity.

Internal Air Cylinder Linear Thruster Slides | Dimensions and Technical Specifications

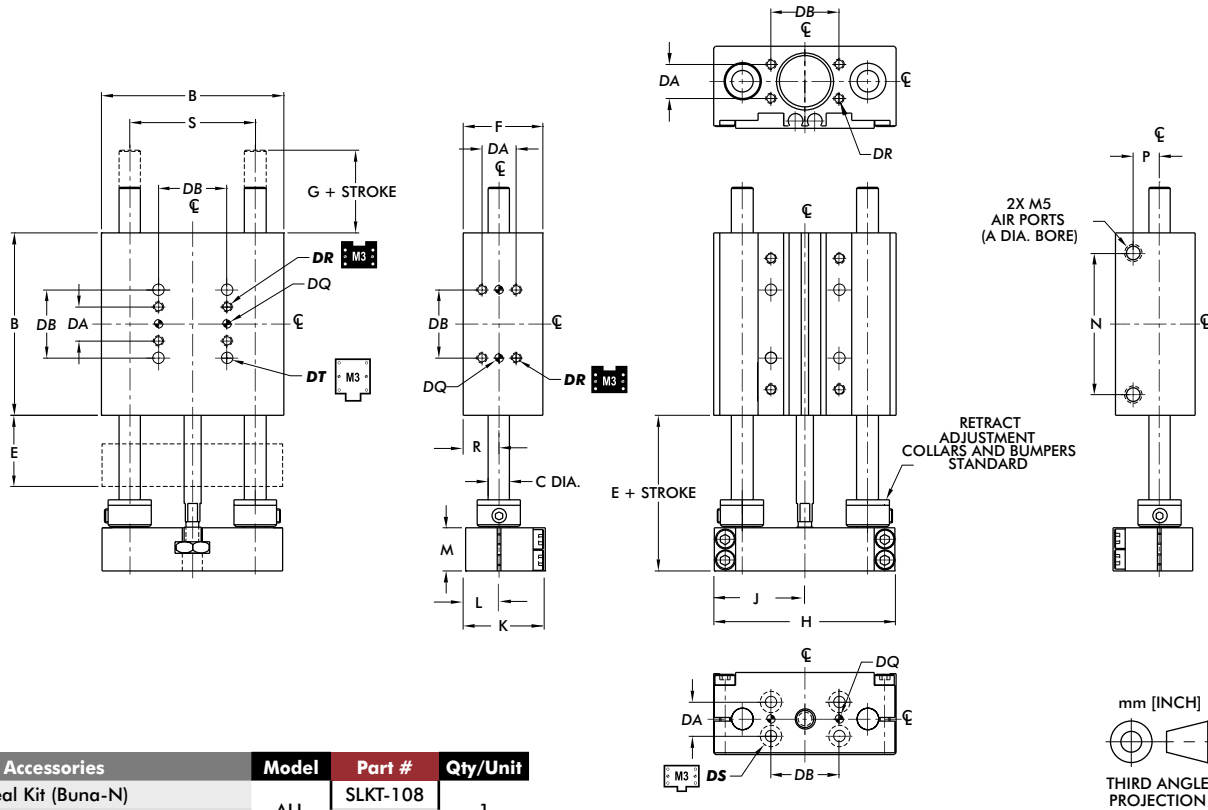

Pneumatic Accessories	Model	Part #	Qty/Unit
Cylinder Seal Kit (Buna-N)	ALL	SLKT-108	1
Cylinder Seal Kit (Viton®)		SLKT-108V	

DIRECTCONNECT™ Mounting Pattern Dimensions (all sizes)					
DA	DB	DQ	DR	DS	DT
9.5 [0.375]	19.1 [0.750]	3H7 x 2 DP	M3 x 6 DP	CLR & C'BORE FOR M3	CLR & C'BORE FOR M3

Model	Bore Ø Body Size Shaft Ø			Basic Unit Dimensions											
	A	B	C	E	F	G	H	J	K	L	M	N	P	R	S
DLT-06M	14 [0.563]	50.8 [2.00]	6.0 [0.236]	19.9 [0.783]	22.4 [0.88]	16.8 [0.66]	50.3 [1.980]	25.1 [0.990]	22.2 [0.875]	9.3 [0.365]	11.9 [0.470]	39.4 [1.55]	7.4 [0.29]	9.9 [0.390]	34.93 [1.375]
DLT-08M		63.5 [2.50]	8.0 [0.315]			10.4 [0.41]	62.7 [2.470]	31.0 [1.235]				52.1 [2.05]			44.45 [1.750]

Dimensions in mm [in]

Loading Information

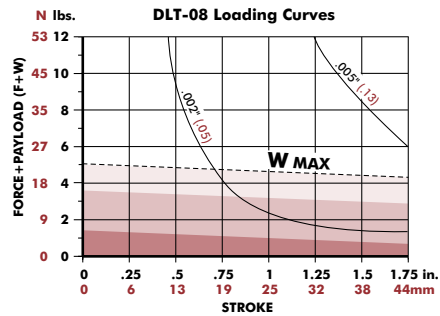
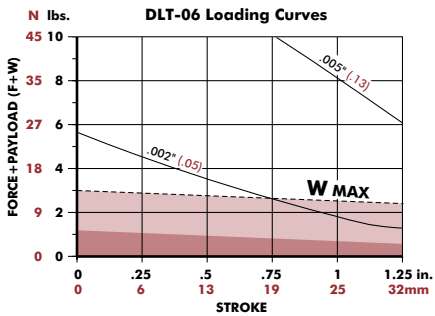

F=Externally applied force
 W=Weight of payload
 F+W=Total force
 M=Maximum moment (in-lb. or N-m)

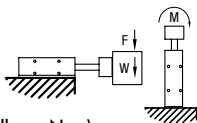

Shock Absorbers and Flow Controls are recommended for all applications

Use Double Shocks in both directions Use Single Shock in both directions Use Bumpers or Cushioned Cylinder

Shaded shock absorption ranges of horizontal payload (W) @ 80psi, flow controls fully open. For vertical applications do not exceed 1/2 of the recommended payload due to the additional acceleration effect of gravity.



Internal Air Cylinder Linear Thruster Slides | Dimensions and Technical Specifications

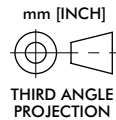
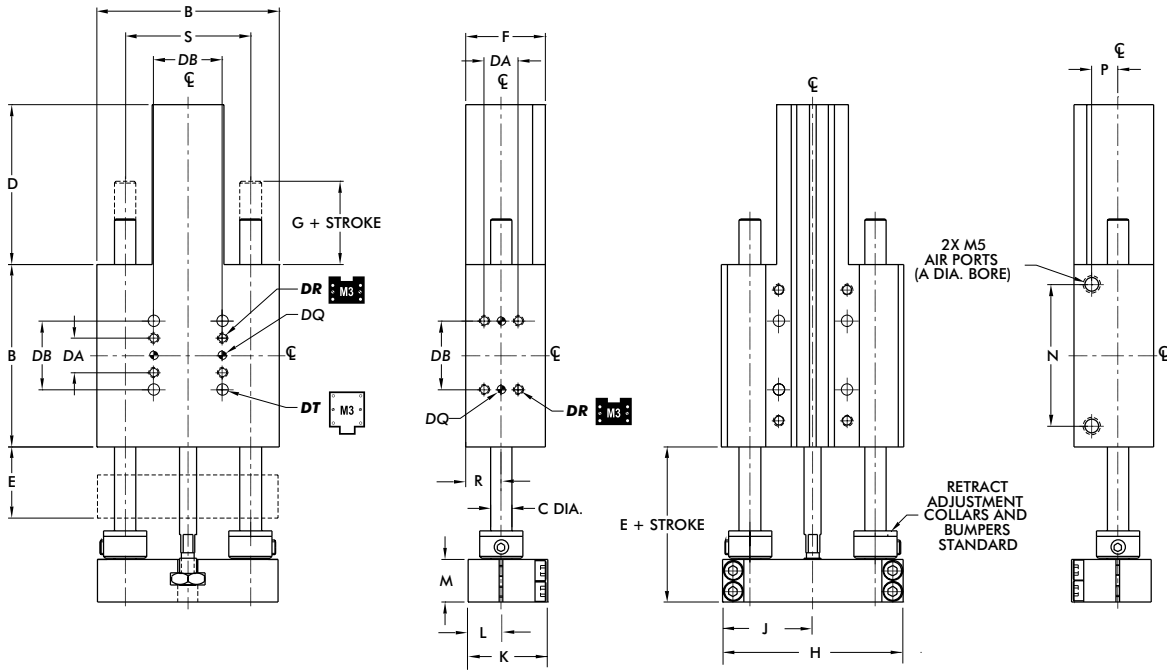

Pneumatic Accessories	Model	Part #	Qty/Unit
Cylinder Seal Kit (Buna-N)	ALL	SLKT-108	1
Cylinder Seal Kit (Viton®)		SLKT-108V	

DIRECTCONNECT™ Mounting Pattern Dimensions (all sizes)					
DA	DB	DQ	DR	DS	DT
9.5 [0.375]	19.1 [0.750]	3H7 x 2 DP	M3 x 6 DP	CLR & C'BORE FOR M3	CLR & C'BORE FOR M3

Model	Bore Ø	Body Size	Shaft Ø	Basic Unit Dimensions												
				A	B	C	D	E	F	G	H	J	K	L	M	N
DLT-06M	14 [0.563]	50.8 [2.00]	6.0 [0.236]	44.4 [1.75]	19.9 [0.783]	22.4 [0.88]	16.8 [0.66]	50.3 [1.980]	25.1 [0.990]	22.2 [0.875]	9.3 [0.365]	11.9 [0.470]	39.4 [1.55]	5.4 [0.21]	9.9 [0.390]	34.93 [1.375]
DLT-08M		63.5 [2.50]	8.0 [0.315]				10.4 [0.41]	62.7 [2.470]	31.0 [1.235]				52.1 [2.05]			44.45 [1.750]

Dimensions in mm [in]

Loading Information

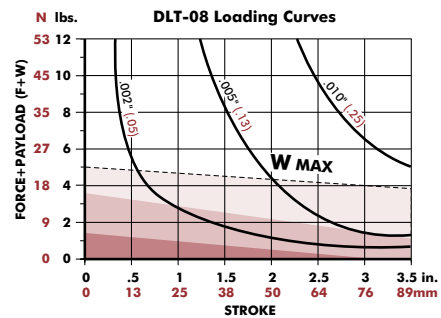
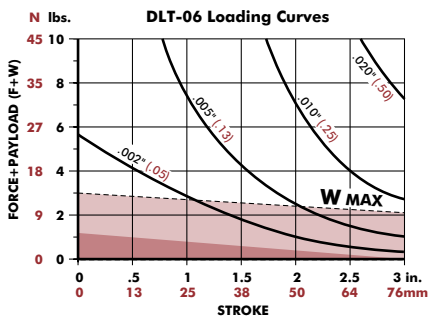

F=Externally applied force

W=Weight of payload

F+W=Total force

M=Maximum moment (in-lb. or N-m)

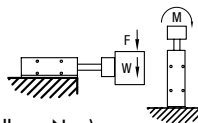

Shock Absorbers and Flow Controls are recommended for all applications

Use **Double Shocks** in both directions

Use **Single Shock** in both directions

Use **Bumpers or Cushioned Cylinder**

Shaded shock absorption ranges of horizontal payload (W) @ 80psi, flow controls fully open. For vertical applications do not exceed 1/2 of the recommended payload due to the additional acceleration effect of gravity.

DLT-10/12/16M-B

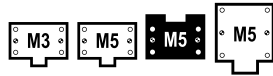

Internal Air Cylinder Linear Thruster Slides | Dimensions and Technical Specifications

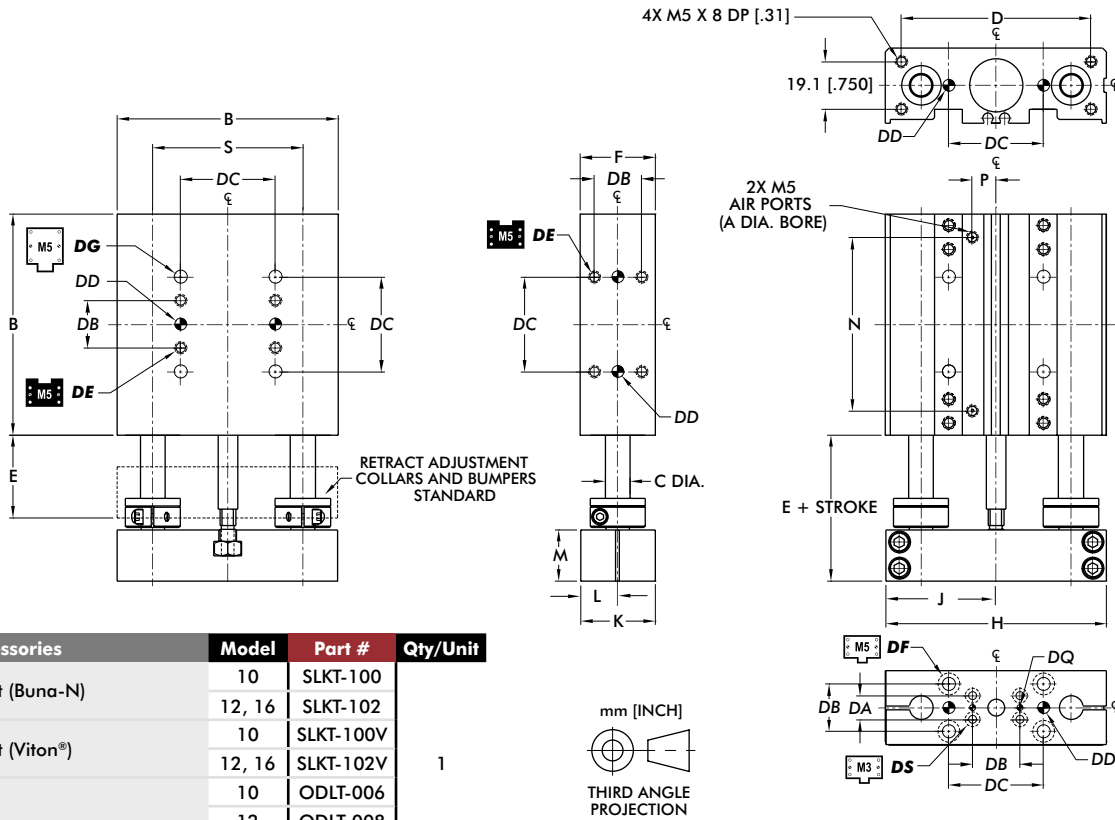

Pneumatic Accessories	Model	Part #	Qty/Unit
Cylinder Seal Kit (Buna-N)	10	SLKT-100	1
	12, 16	SLKT-102	
	10	SLKT-100V	
Cylinder Seal Kit (Viton®)	12, 16	SLKT-102V	
	10	ODLT-006	
Base Flange Kit (See page GR-LIN-36 for information)	12	ODLT-008	
	16	ODLT-010	

DIRECTCONNECT™ Mounting Pattern Dimensions (all sizes)							
DA	DB	DC	DD	DE	DF	DG	DS
9.5 [0.375]	19.1 [0.750]	38.1 [1.500]	5mm H7 x 6 DP	M5 x 8.5 DP	CLEARANCE FOR M5	3H7 x 2 DP	CLR & C'BORE FOR M3

Model	Bore Ø		Body Size		Shaft Ø		Basic Unit Dimensions							
	A	B	C	D	E	F	H	J	K	L	M	N	P	S
DLB-10	19 [0.75]	88.9 [3.50]	9.5 [0.375]	76.2 [3.000]	33.4 [1.313]	30.2 [1.19]	88.6 [3.490]	44.2 [1.740]	29.9 [1.178]	14.8 [0.584]	20.7 [0.813]	69.7 [2.75]	9.4 [0.37]	60.33 [2.375]
DLB-12	25 [0.98]	101.6 [4.00]	12.0 [0.472]	92.1 [3.625]		41.4 [1.63]	101.2 [3.985]	50.4 [1.985]	41.0 [1.615]	20.4 [0.802]		83.3 [3.28]		69.85 [2.750]
DLB-16		120.7 [4.75]	16.0 [0.630]	111.1 [4.375]	34.9 [1.375]	120.3 [4.735]	59.9 [2.360]	102.4 [4.03]			82.55 [3.250]			

Dimensions in mm [in]

Loading Information

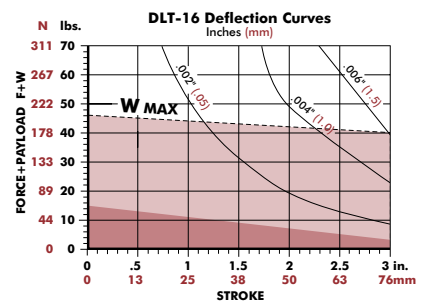
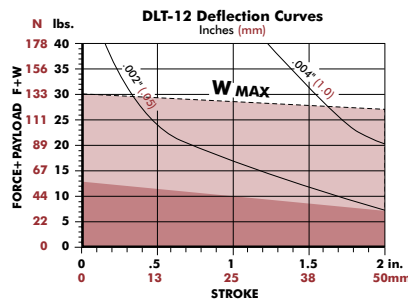
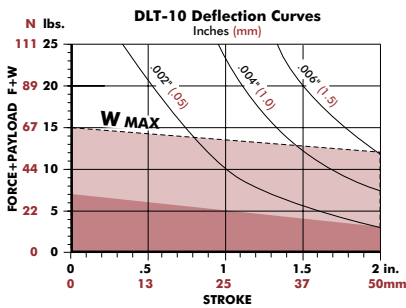

Shock Absorbers and Flow Controls are recommended for all applications

F=Externally applied force

W=Weight of payload

F+W=Total force

M=Maximum moment (in-lb. or N-m)

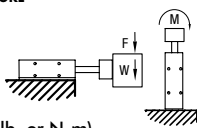

(W) in this range use Single Shock in retract directions

(W) in this range use Bumpers or Cushioned Cylinder

Shaded shock absorption ranges of horizontal payload (W) @ 80psi, flow controls fully open. For vertical applications do not exceed 1/2 of the recommended payload due to the additional acceleration effect of gravity.



Internal Air Cylinder Linear Thruster Slides | Dimensions and Technical Specifications

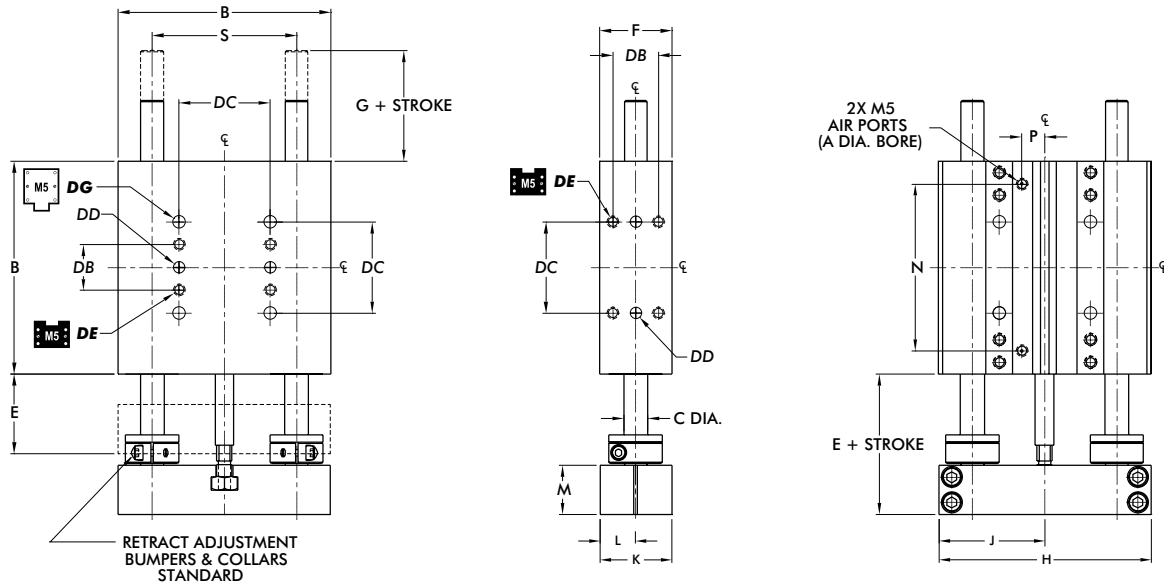

RETRACT ADJUSTMENT
BUMPERS & COLLARS
STANDARD

Pneumatic Accessories	Model	Part #	Qty/Unit
Cylinder Seal Kit (Buna-N)	10	SLKT-100	1
	12, 16	SLKT-102	
Cylinder Seal Kit (Viton®)	10	SLKT-100V	
	12, 16	SLKT-102V	

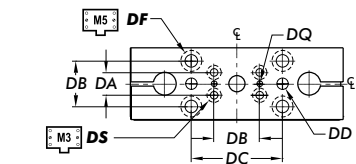
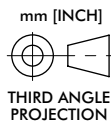

DIRECTCONNECT™ Mounting Pattern Dimensions (all sizes)								
DA	DB	DC	DD	DE	DF	DG	DQ	DS
9.5 [0.375]	19.1 [0.750]	38.1 [1.500]	5mm H7 x 6 DP	M5 x 8.5 DP	CLEARANCE FOR M5		3H7 x 2 DP	CLR & C'BORE FOR M3

Model	Bore Ø Body Size Shaft Ø			Basic Unit Dimensions											
	A	B	C	E	F	G	H	J	K	L	M	N	P	S	
DLB-10	19 [3/4]	88.9 [3.50]	9.5 [0.375]	33.4 [1.313]	30.2 [1.19]	20.8 [0.82]	88.6 [3.490]	44.2 [1.740]	29.9 [1.178]	14.8 [0.584]		69.7 [2.75]		60.33 [2.375]	
DLB-12	25 [1]	101.6 [4.00]	12.0 [0.472]		41.4 [1.63]		101.2 [3.985]	50.4 [1.985]	41.0 [1.615]	20.4 [0.802]	20.7 [0.813]	83.3 [3.28]	9.4 [0.37]	69.85 [2.750]	
DLB-16		120.7 [4.75]	16.0 [0.630]	34.9 [1.375]	19.3 [0.76]	120.3 [4.735]	59.9 [2.360]						102.4 [4.03]		82.55 [3.250]

Dimensions in mm [in]

Loading Information

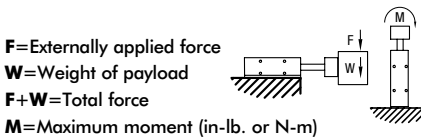
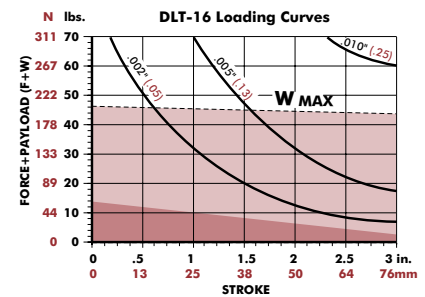
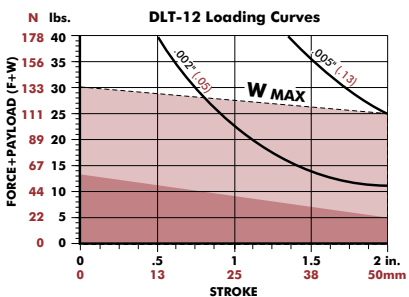
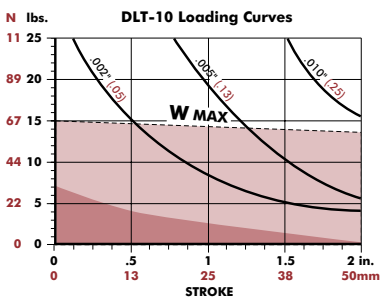

Shock Absorbers and Flow Controls are recommended for all applications

(W) in this range use **Single Shock** in retract directions

(W) in this range use **Bumpers or Cushioned Cylinder**

Shaded shock absorption ranges of horizontal payload (W) @ 80psi, flow controls fully open. For vertical applications do not exceed 1/2 of the recommended payload due to the additional acceleration effect of gravity.

DLT-10/12/16M-L

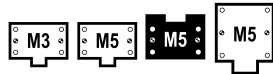

Internal Air Cylinder Linear Thruster Slides | Dimensions and Technical Specifications

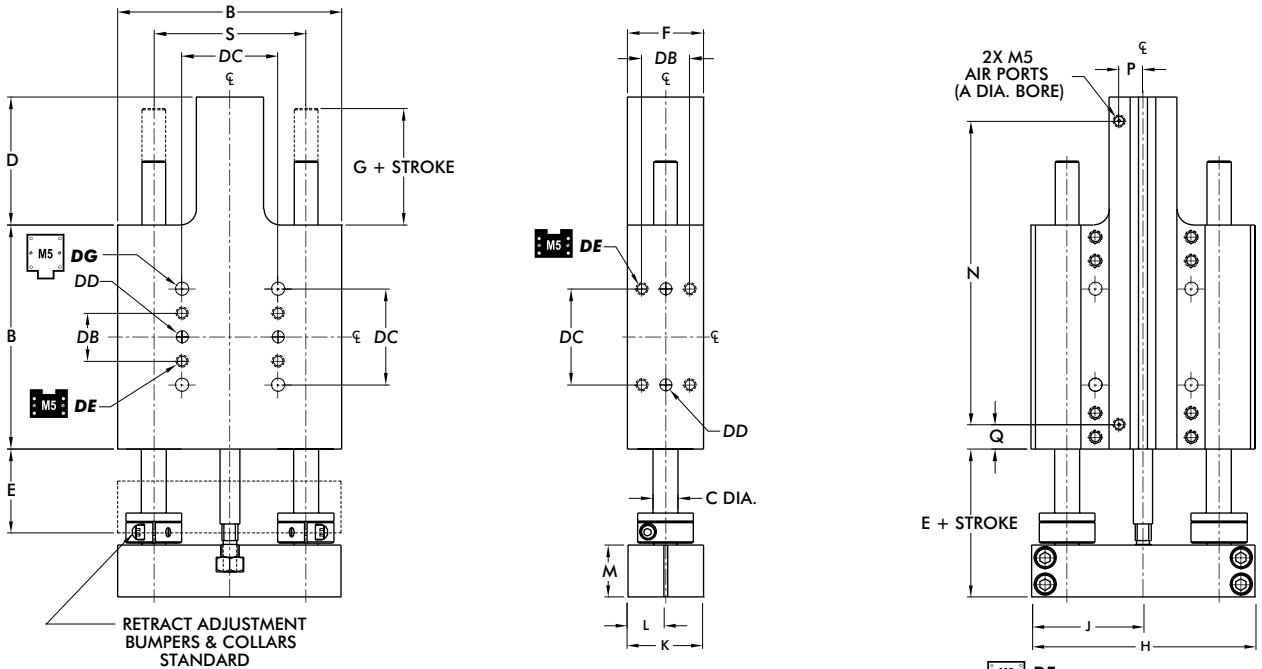

Pneumatic Accessories	Model	Part #	Qty/Unit
Cylinder Seal Kit (Buna-N)	10	SLKT-100	1
	12, 16	SLKT-102	
Cylinder Seal Kit (Viton®)	10	SLKT-100V	
	12, 16	SLKT-102V	

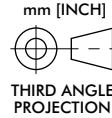

DIRECTCONNECT™ Mounting Pattern Dimensions (all sizes)								
DA	DB	DC	DD	DE	DF	DG	DQ	DS
9.5 [0.375]	19.1 [0.750]	38.1 [1.500]	5mm H7 x 6 DP	M5 x 8.5 DP	CLEARANCE FOR M5		3H7 x 2 DP	CLR & C'BORE FOR M3

Model	Bore Ø	Body Size	Shaft Ø	Basic Unit Dimensions												
				A	B	C	D	E	F	G	H	J	K	L	M	N
DLB-10	19 [3/4]	88.9 [3.50]	9.5 [0.375]	50.8 [2.00]	33.4 [1.313]	30.2 [1.19]	20.8 [0.82]	88.6 [3.490]	44.2 [1.740]	29.9 [1.178]	14.8 [0.584]		120.7 [4.75]	9.6 [0.38]	9.6 [0.38]	60.33 [2.375]
DLB-12	25 [1]	101.6 [4.00]	12.0 [0.472]	63.5 [2.50]	41.4 [1.63]			101.2 [3.985]	50.4 [1.985]	41.0 [1.615]	20.4 [0.802]	20.7 [0.813]	146.8 [5.78]	9.4 [0.37]	9.1 [0.36]	69.85 [2.750]
DLB-16		120.7 [4.75]	16.0 [0.630]	69.9 [2.75]				34.9 [1.375]	19.3 [0.76]				120.3 [4.735]			59.9 [2.360]

Dimensions in mm [in]

Loading Information

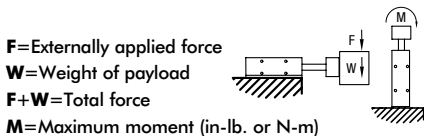
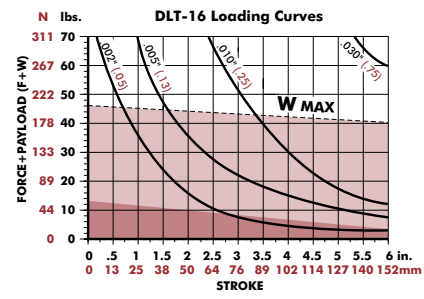
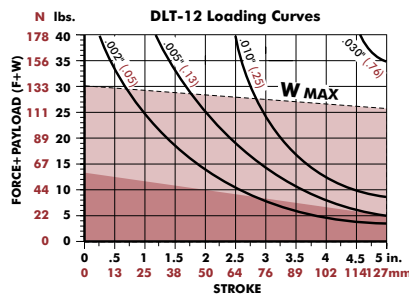
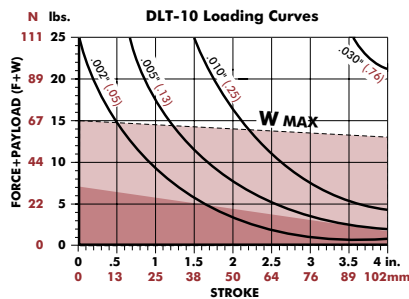

Shock Absorbers and Flow Controls are recommended for all applications

(W) in this range use **Single Shock** in retract directions (W) in this range use **Bumpers or Cushioned Cylinder**

Shaded shock absorption ranges of horizontal payload (W) @ 80psi, flow controls fully open. For vertical applications do not exceed 1/2 of the recommended payload due to the additional acceleration effect of gravity.



Internal Air Cylinder Linear Thruster Slides | Dimensions and Technical Specifications

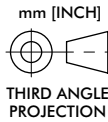
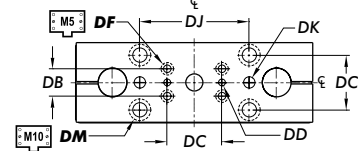
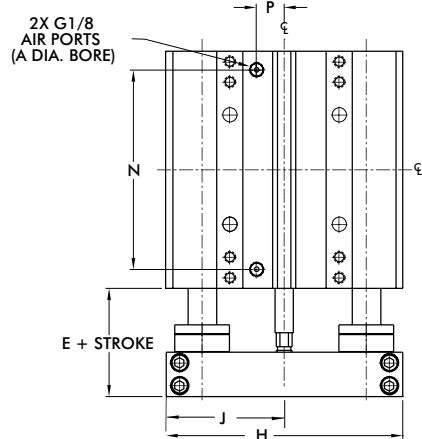
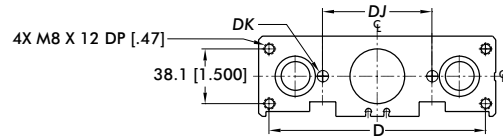
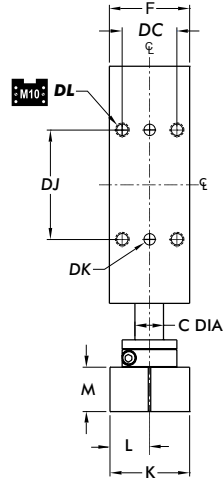
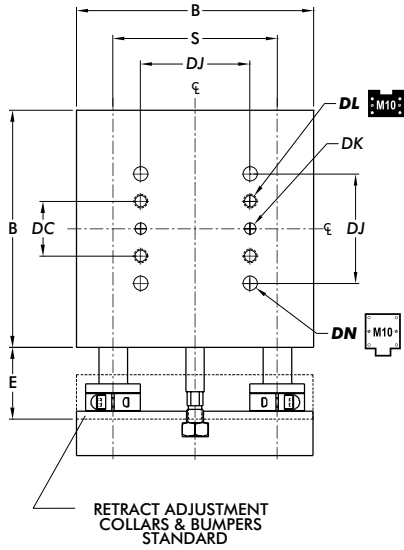

Pneumatic Accessories	Model	Part #	Qty/Unit
Cylinder Seal Kit (Buna-N)	20	SLKT-104	1
Cylinder Seal Kit (Viton®)	25	SLKT-104V	
Base Flange Kit (See page GR-LIN-36 for information)	20	ODLT-012	
	25	ODLT-014	

DIRECTCONNECT™ Mounting Pattern Dimensions (all sizes)									
DB	DC	DD	DF	DJ	DK	DL	DM	DN	
19.1 [0.750]	38.1 [1.500]	5mm H7 x 6 DP	CLEARANCE FOR M5	76.2 [3.000]	8mm H7 x 9.4 DP	M10 x 14.2 DP	CLR & C'BORE FOR M10		

Model	Bore Ø	Body Size	Shaft Ø	Basic Unit Dimensions										
				A	B	C	D	E	F	H	J	K	L	M
DLB-20	38 [1 1/2]	165.1 [6.50]	20 [0.787]	150.8 [5.938]	49.8 [1.960]	55.9 [2.20]	164.6 [6.480]	82.0 [3.230]	55.4 [2.180]	27.4 [1.080]	30.7 [1.210]	138.9 [5.47]	19.5 [0.77]	114.30 [4.500]
DLB-25		190.5 [7.50]	25 [0.984]	176.2 [6.938]	55.1 [2.170]		190.0 [7.480]	94.7 [3.730]			36.1 [1.420]	164.3 [6.47]		

Dimensions in mm [in]

Loading Information

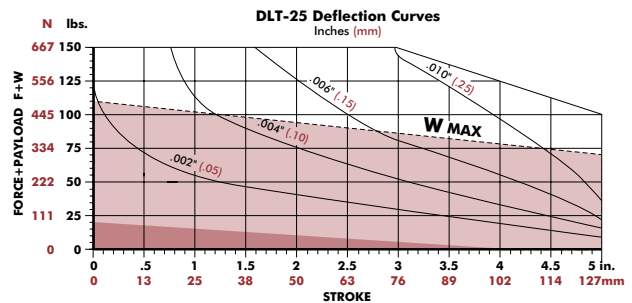
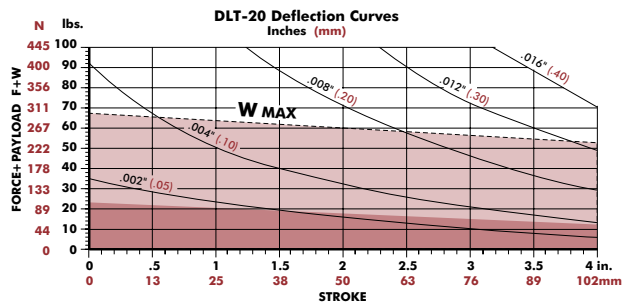

F=Externally applied force

W=Weight of payload

F+W=Total force

M=Maximum moment (in-lb. or N-m)

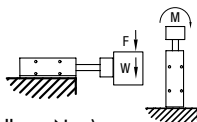

Shock Absorbers and Flow Controls are recommended for all applications

(W) in this range use **Single Shock** in retract directions

(W) in this range use **Bumpers or Cushioned Cylinder**

Shaded shock absorption ranges of horizontal payload (W) @ 80psi, flow controls fully open. For vertical applications do not exceed 1/2 of the recommended payload due to the additional acceleration effect of gravity.

DLT-20/25M-E



Internal Air Cylinder Linear Thruster Slides | Dimensions and Technical Specifications

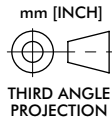
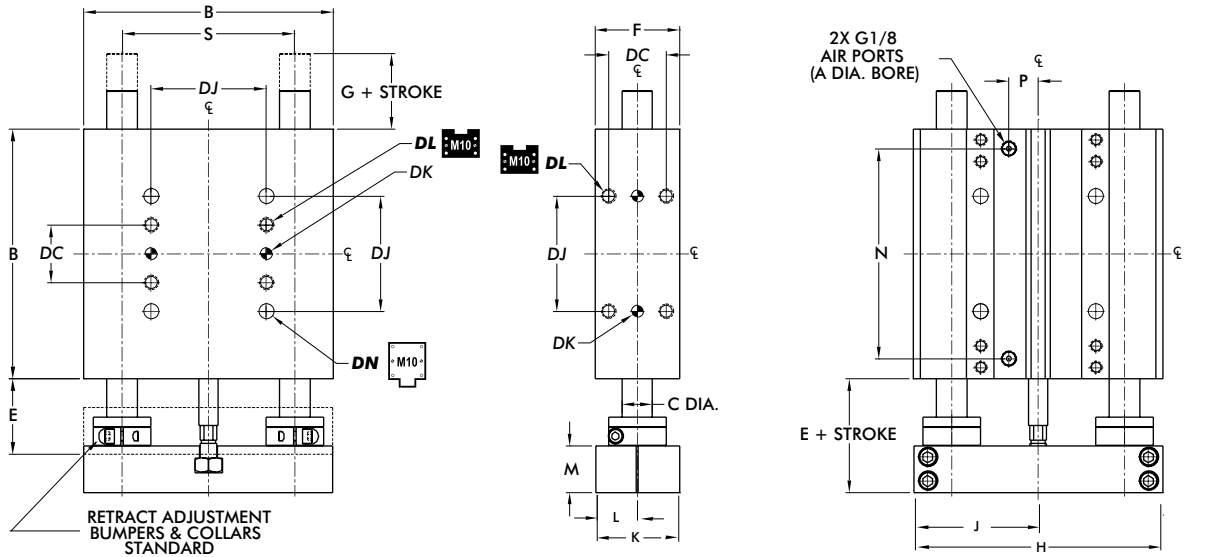

Pneumatic Accessories	Model	Part #	Qty/Unit
Cylinder Seal Kit (Buna-N)	20	SLKT-104	1
Cylinder Seal Kit (Viton®)	25	SLKT-104V	1

DIRECTCONNECT™ Mounting Pattern Dimensions (all sizes)									
DB	DC	DD	DF	DJ	DK	DL	DM	DN	
19.1 [0.750]	38.1 [1.500]	5mm H7 x 6 DP	CLEARANCE FOR M5	76.2 [3.000]	8mm H7 x 9.4 DP	M10 x 14.2 DP	CLR & C'BORE FOR M10		

Model	Bore Ø	Body Size	Shaft Ø	Basic Unit Dimensions											
				A	B	C	E	F	G	H	J	K	L	M	N
DLT-20	38	165.1 [6.50]	20 [0.787]	49.8 [1.960]	55.9 [2.20]	24.4 [0.960]	164.6 [6.480]	82.0 [3.230]		55.4 [2.180]	27.4 [1.080]	30.7 [1.210]	138.9 [5.47]	19.5 [0.77]	114.30 [4.300]
DLT-25	[1 1/2]	190.5 [7.50]	25 [0.984]	55.1 [2.170]		29.7 [1.170]	190.0 [7.480]	94.7 [3.730]				36.1 [1.420]	164.3 [6.47]		133.35 [5.250]

Dimensions in mm [in]

Loading Information

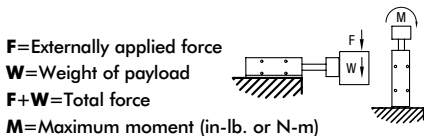
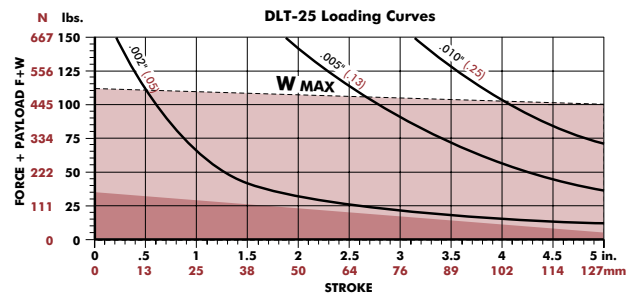
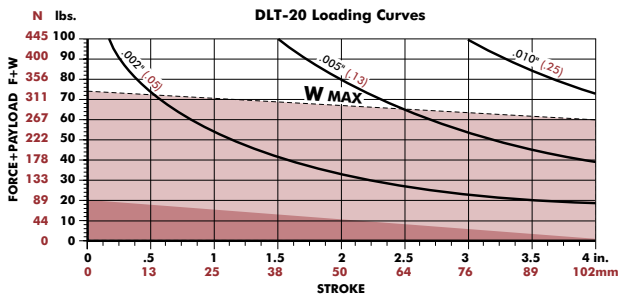

Shock Absorbers and Flow Controls are recommended for all applications

(W) in this range use **Single Shock** in retract directions (W) in this range use **Bumpers or Cushioned Cylinder**

Shaded shock absorption ranges of horizontal payload (W) @ 80psi, flow controls fully open. For vertical applications do not exceed 1/2 of the recommended payload due to the additional acceleration effect of gravity.

Internal Air Cylinder Linear Thruster Slides | Dimensions and Technical Specifications

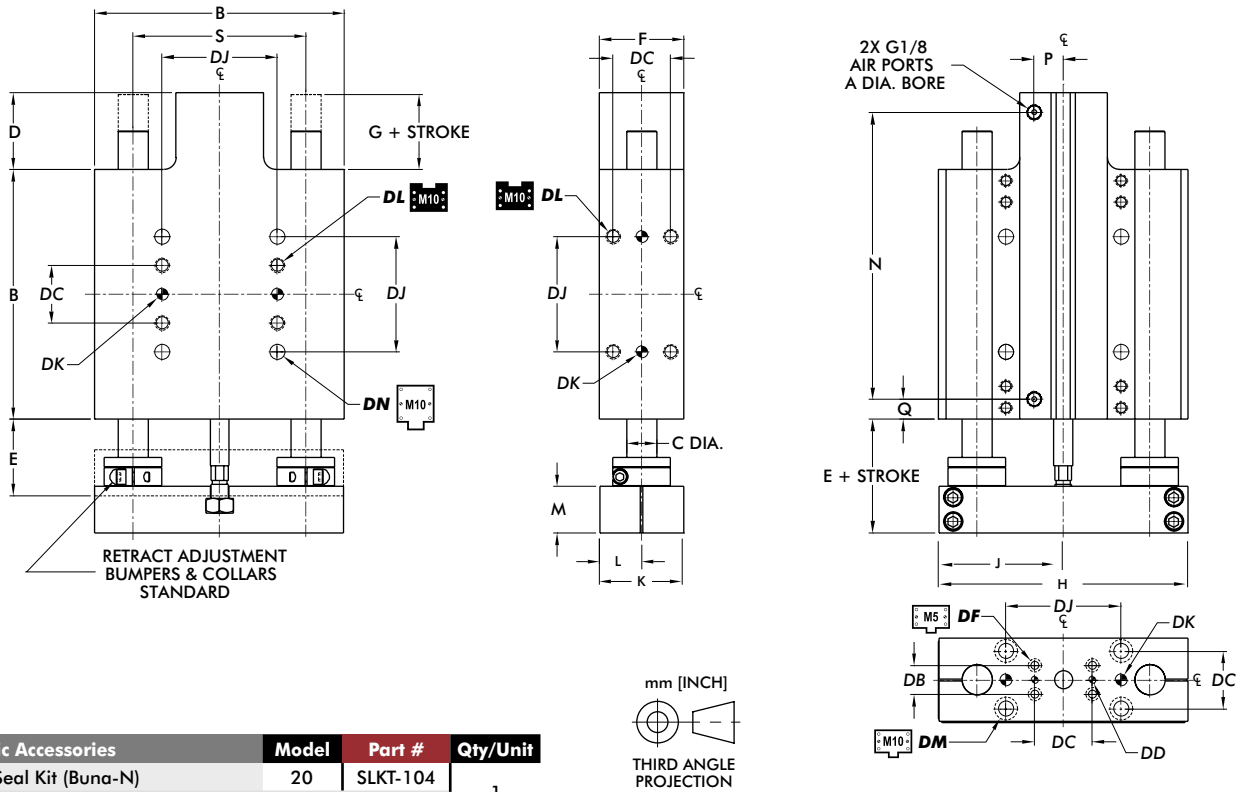

Pneumatic Accessories	Model	Part #	Qty/Unit
Cylinder Seal Kit (Buna-N)	20	SLKT-104	1
Cylinder Seal Kit (Viton®)	25	SLKT-104V	1

DIRECTCONNECT™ Mounting Pattern Dimensions (all sizes)									
DB	DC	DD	DF	DJ	DK	DL	DM	DN	
19.1 [0.750]	38.1 [1.500]	5mm H7 x 6 DP	CLEARANCE FOR M5	76.2 [3.000]	8mm H7 x 9.4 DP	M10 x 14.2 DP	CLR & C'BORE FOR M10		

Model	Bore Ø	Body Size	Shaft Ø	Basic Unit Dimensions												
				A	B	C	D	E	F	G	H	J	K	L	M	N
DLT-20	38 [1 1/2]	165.1 [6.50]	20 [0.787]	50.8 [2.00]	49.8 [1.960]	55.9 [2.20]	24.4 [0.960]	164.6 [6.480]	82.0 [3.230]	55.4 [2.180]	27.4 [1.080]	30.7 [1.210]	189.7 [7.469]	19.4 [0.77]	13.1 [0.52]	114.30 [4.500]
DLT-25		190.5 [7.50]	25 [0.984]	55.1 [2.170]	29.7 [1.170]	190.0 [7.480]	94.7 [3.730]	36.1 [1.420]	215.1 [8.468]							

Dimensions in mm [in]

Loading Information

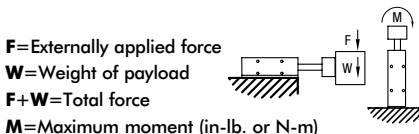
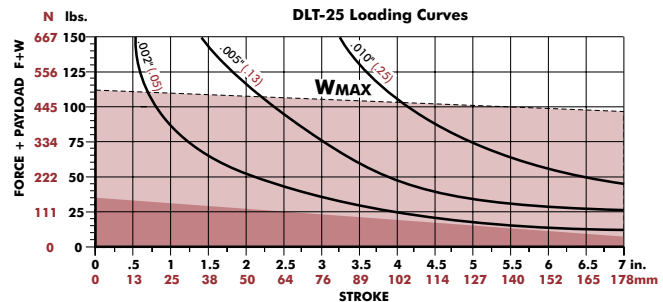
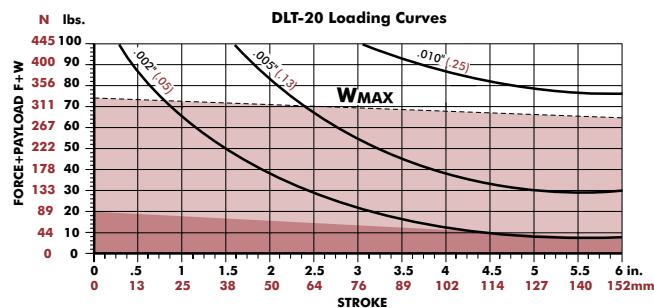

Shock Absorbers and Flow Controls are recommended for all applications

(W) in this range use **Single Shock** in retract directions (W) in this range use **Bumpers or Cushioned Cylinder**

Shaded shock absorption ranges of horizontal payload (W) @ 80psi, flow controls fully open. For vertical applications do not exceed 1/2 of the recommended payload due to the additional acceleration effect of gravity.

DLT SERIES - EXTERNAL AIR CYLINDER

External Air Cylinder Linear Thruster Slides | Features and Benefits | How To Order

Features:

- Bearing system for smooth operation
- Rugged design produces very reliable long life operation
- Replaceable air cylinder with adjustable cushions
- Urethane bumpers, hardened pads, oil wick
- Optional telescopic airlines transfers air to tooling
- DIRECTCONNECT™ mounting pattern
- Corrosion resistant shafting for corrosive environments
- Position sensing using inductive or magneto resistive sensors

Applications:

- Machining and automation applications
- Harsh environment pick-and-place applications
- X Y Table Applications

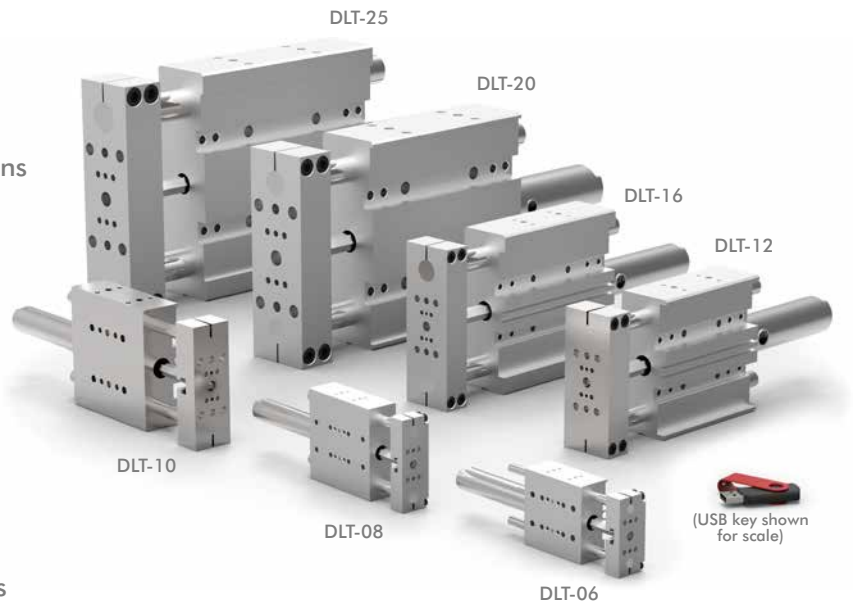

How To Order

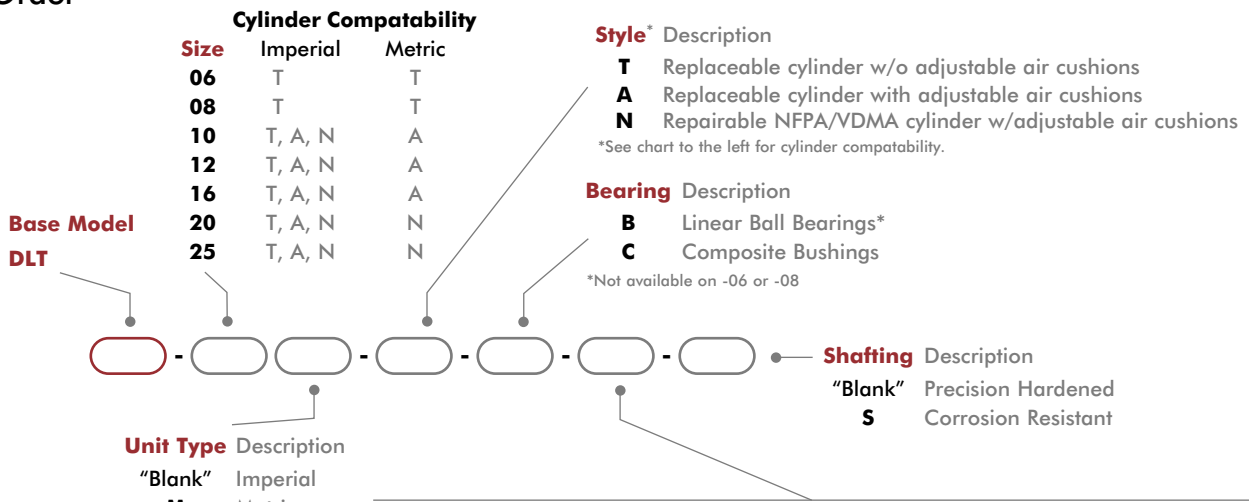

Size	Style	Stroke* Imperial (in)
DLT-06	T	.5, 1, 1.5, 2, 2.5, 3, 4, 5, 6
DLT-08	T	.5, 1, 1.5, 2, 2.5, 3, 4, 5, 6, 7, 8
DLT-10	T, A, N	1-12 @ 1" increments
DLT-12	T, A, N	1-16 @ 1" increments
DLT-16	T, A, N	1-20 @ 1" increments
DLT-20	T, A, N	1-24 @ 1" increments
DLT-25	T, A, N	1-26 @ 1" increments

Size	Style	Stroke* Metric (mm)
DLT-06M	T	10, 25, 40, 50, 75, 100, 125, 160
DLT-08M	T	10, 25, 40, 50, 75, 100, 125, 160, 175, 200
DLT-10M	A	25, 50, 80, 100, 125, 160, 200, 250, 300
DLT-12M	A	25, 50, 80, 100, 125, 160, 200, 250, 300, 320, 360, 400
DLT-16M	A	25, 50, 80, 100, 125, 160, 200, 250, 300, 320, 360, 400, 500
DLT-20M	N	25, 50, 80, 100, 125, 160, 200, 250, 300, 320, 360, 400, 500
DLT-25M	N	25, 50, 80, 100, 125, 160, 200, 250, 300, 320, 360, 400, 500

*Custom strokes available. Consult factory.

DLT SERIES - EXTERNAL AIR CYLINDER

External Air Cylinder Linear Thruster Slides | Accessories

Shock/Stop & Mounting Accessories	Model Numbers	Style	Part Number	Qty/Unit
Universal Mounting Kit (Stop/Shock)	06	All	OSAK-069	1-4
	08		OSAK-070	
Universal Mounting Kit (Stop/Shock/Sensor)	10		OSAK-055	
	12		OSAK-057	
	16		OSAK-059	
	20		OSAK-061	
	25		OSAK-063	
	06, 08		SHOK-030	
Shock Absorber (2 Max on -06)	10		SHOK-028	
	12, 16,		SHOK-010	
	20, 25		SHOK-029	
Adjustable Hard Stop	06, 08		DLT-0623	
	10, 12, 16, 20, 25		DLT-1023	
Urethane Bumper/Stop Collar Kit	06		OSAK-067	
	08	OSAK-068		
	10	OSAK-065		
	12	OSAK-066		
	16	OSAK-060		
	20	OSAK-062		
25	OSAK-064			
Sensor Accessories	Model Numbers	Style	Part Number	Qty/Unit
Inductive Sensor Mounting Kit	06	T	OSMK-076	1
Inductive Sensor Mounting Kit	08		OSMK-077	
PNP Inductive Sensor with Quick Disconnect*	06, 08	T	OISP-014	1-2
NPN Inductive Sensor with Quick Disconnect*			OISN-014	
PNP Inductive Sensor with Quick Disconnect*	10, 12, 16, 20, 25	T, A, N	OISP-011	
NPN Inductive Sensor with Quick Disconnect*			OISN-011	
PNP Magneto Resistive Sensor w/Qk Disconnect*	06, 08, 10, 12, 16	T, A, N	OHSP-005	1-2
NPN Magneto Resistive Sensor w/Qk Disconnect*			OHSN-005	
PNP Magneto Resistive Sensor w/Qk Disconnect*	20, 25	N	OHSP-020	
NPN Magneto Resistive Sensor w/Qk Disconnect*			OHSN-020	
Quick Disconnect 2 Meter Cable Length*	All Model	All	CABL-010	1-2
Quick Disconnect 5 Meter Cable Length*			CABL-013	
Cable Extension Cord 1M Length*	All Models	All	CABL-015	
Cable Extension Cord 2M Length*			CABL-016	
Pneumatic Accessories	Model Numbers	Style	Part Number	Qty/Unit
1/8 NPT Telescopic Airlines (up to 6")	10, 12, 16	All	OTAL-039	1-4
1/8 NPT Telescopic Airlines (up to 12")	10, 12, 16		OTAL-040	
1/8 NPT Telescopic Airlines (up to 18")	10, 12, 16, 20, 25		OTAL-041	
1/8 NPT Telescopic Airlines (up to 24")	20, 25		OTAL-042	
#10-32 NPT Adjustable Flow Control	06, 08		VLVF-007	1-2
1/8 NPT Adjustable Flow Control	10, 12, 16, 20, 25		VLVF-004	
G1/8 Telescopic Airlines (up to 160mm)	10, 12, 16		OTAL-045	1-4
G1/8 Telescopic Airlines (up to 300mm)	10, 12, 16		OTAL-046	
G1/8 Telescopic Airlines (up to 450mm)	10, 12, 16, 20, 25		OTAL-047	
G1/8 Telescopic Airlines (up to 600mm)	20, 25		OTAL-048	
M5 Adjustable Flow Control	06, 08		VLVF-008	1-2
G1/8 Adjustable Flow Control	10, 12, 16, 20, 25		VLVF-005	

*Sensor and cable sold separately.

See page GR-LIN-36 for Accessory Mounting Technical Data

DLT SERIES - EXTERNAL AIR CYLINDER

External Air Cylinder Linear Thruster Slides | Technical Specifications

Specifications	Units	06	08	10	12	16	20	25
Max. Air Pressure	bar [psi]	7 [100]						
Thrust Force @ 5.5 bar [80psi]	N [lbs]	111 [20]	89 [20]	173 [35]	270 [70]	270 [70]	443 [140]	443 [140]
Weight (basic unit)	kg [lb]	0.24 [0.53]	0.40 [0.88]	1.05 [2.12]	1.64 [3.42]	2.11 [4.47]	6.3 [14.3]	8.5 [19.2]
Additional Weight per Stroke	g/mm [lbs/in]	0.88 [0.05]	1.43 [0.07]	1.2 [0.09]	2.9 [0.15]	4.2 [0.23]	7.9 [0.53]	10.7 [0.68]
Cylinder Bore Ø	mm [in]	16 [0.563]		20 [0.787]	25 [0.984]		32 [1.26]	
Shaft Ø	mm [in]	6 [0.236]	8 [0.315]	9.5 [0.375]	12 [0.472]	16 [0.630]	20 [0.787]	25 [0.984]
Max (M) Vertical Motion	Nm [in-lbs]	0.6 [5]	1.3 [10]	--	--	--	--	--



External Air Cylinder Linear Thruster Slides | Dimensions and Technical Specifications

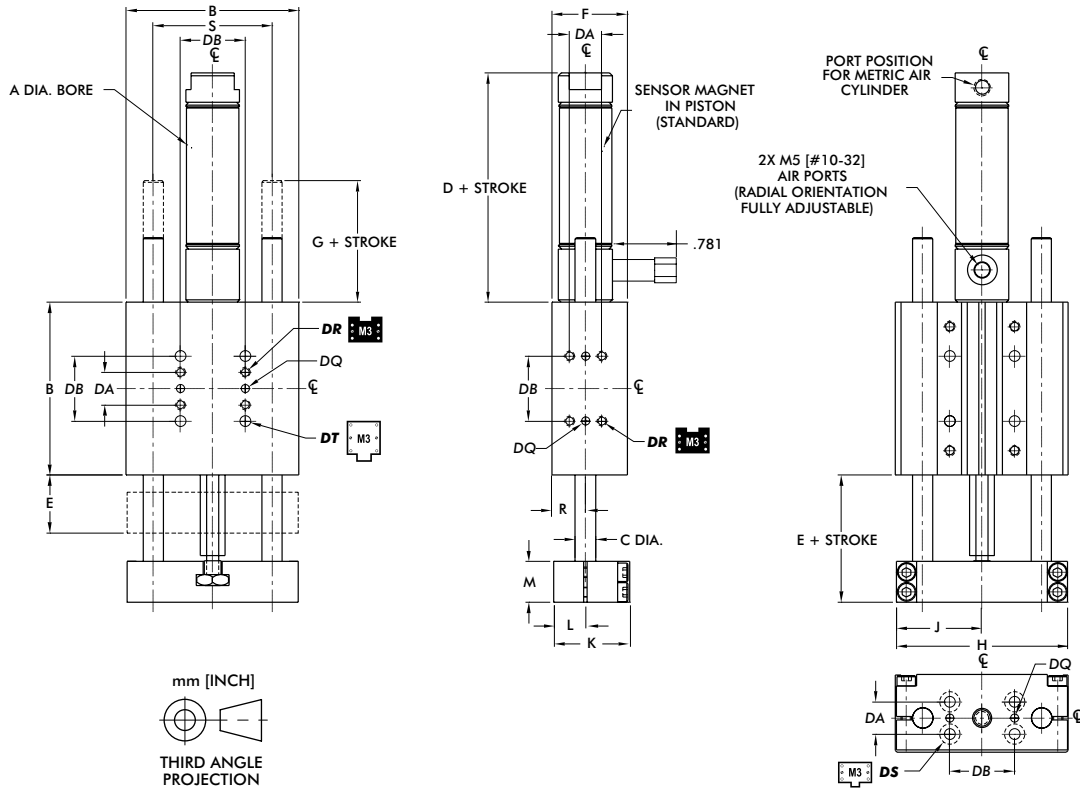

DIRECTCONNECT™ Mounting Pattern Dimensions (all sizes)

DA	DB	DQ	DR	DS	DT
9.5 [0.375]	19.1 [0.750]	3H7 x 2 DP [0.0940 x 0.078 DP]	M3 x 6 DP [#4-40 x 0.25 DP]	CLR & C'BORE FOR M3 [CLR & C'BORE FOR #4]	CLR & C'BORE FOR M3 [CLR & C'BORE FOR #4]

Model	Bore Ø Body Size Shaft Ø			Basic Unit Dimensions										
	A	B	C	D	E	F	G	H	J	K	L	M	R	S
DLT-06	16 [0.63]	50.8 [2.00]	6.0 [0.236]	54.9 [2.16]	19.9 [0.783]	22.4 [0.88]	16.7 [0.66]	50.3 [1.980]	25.1 [0.990]	22.2 [0.875]	9.3 [0.365]	11.9 [0.470]	9.9 [0.390]	34.93 [1.375]
DLT-08		63.5 [2.50]	8.0 [0.315]				10.4 [0.41]	62.7 [2.470]	31.4 [1.235]					44.45 [1.750]

Dimensions in mm [in]

Loading Information

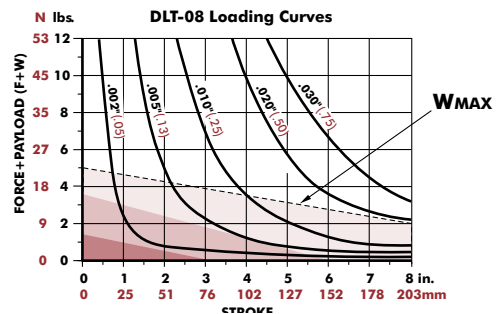
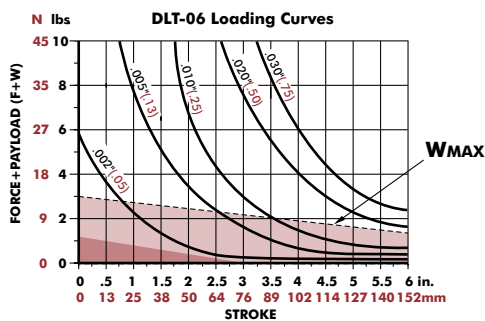

F=Externally applied force

W=Weight of payload

F+W=Total force

M=Maximum moment (in-lb. or N-m)

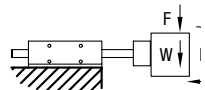

Shock Absorbers and Flow Controls are recommended for all applications

Use **Double Shocks** in both directions

Use **Single Shock** in both directions

Use **Bumpers or Cushioned Cylinder**

Shaded shock absorption ranges of horizontal payload (W) @ 80psi, flow controls fully open. For vertical applications do not exceed 1/2 of the recommended payload due to the additional acceleration effect of gravity.

DLT-10/12/16-T, A



External Air Cylinder Linear Thruster Slides | Dimensions and Technical Specifications

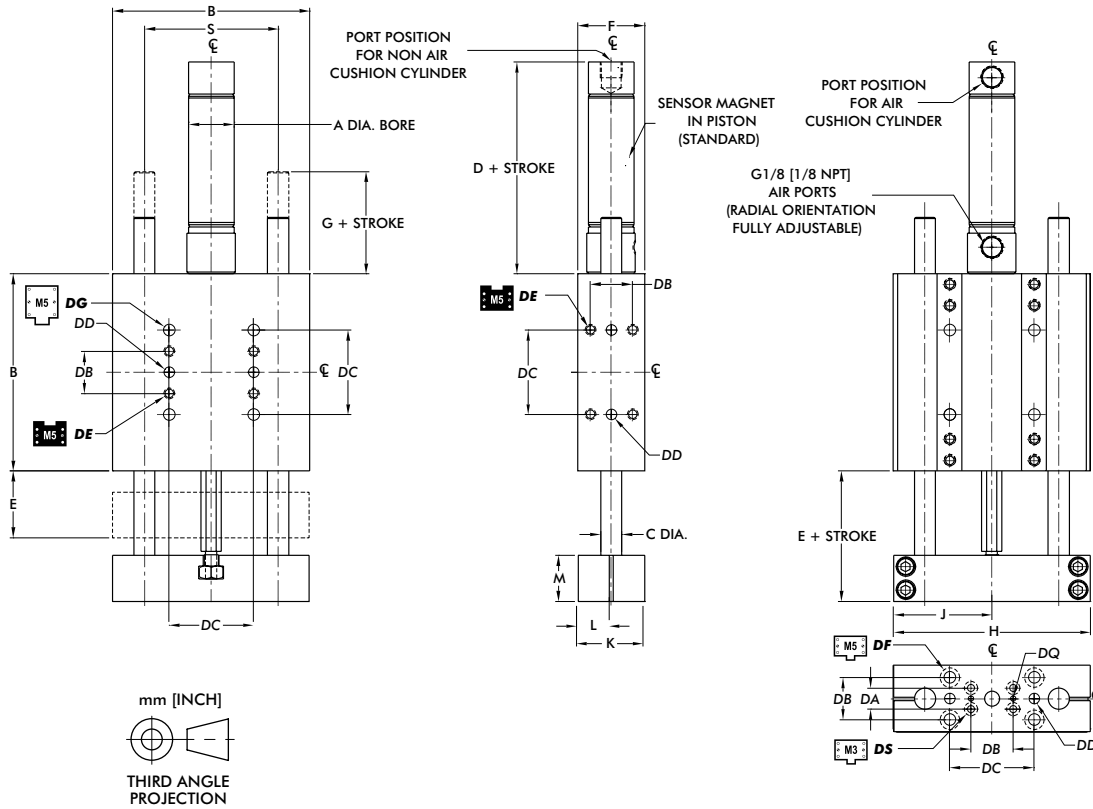

DIRECTCONNECT™ Mounting Pattern Dimensions (all sizes)

DA	DB	DC	DD	DE	DF	DG	DQ	DS
9.5 [0.375]	19.1 [0.750]	38.1 [1.500]	5mm H7 x 6 DP [0.1880 x 0.25 DP]	M5 x 8.5 DP [#10-32 x 0.34 DP]	CLR & C'BORE FOR M5 [CLR & C'BORE FOR #10]		3H7 x 2 DP [0.0940 x 0.078 DP]	CLR & C'BORE FOR M3 [CLR & C'BORE FOR #4]

Model	Bore & Body Dimensions			Basic Unit Dimensions												
	Bore Ø	Body Size	Shaft Ø	A	B	C	D	E	F	G	H	J	K	L	M	S
DLB-10	20 [3/4]	88.9 [3.50]	9.5 [0.375]	88.0 [2.91]				33.4 [1.313]	30.2 [1.19]	20.8 [0.82]	88.6 [3.490]	44.2 [1.740]	29.9 [1.178]	14.8 [0.584]		60.33 [2.375]
DLB-12	25 [1 1/16]	101.6 [4.00]	12.0 [0.472]	91.5 [2.88]					41.4 [1.63]		101.2 [3.985]	50.4 [1.985]			20.7 [0.813]	69.85 [2.750]
DLB-16		120.7 [4.75]	16.0 [0.630]							34.9 [1.375]	19.3 [0.76]	120.3 [4.735]	59.9 [2.360]	41.0 [1.615]	20.4 [0.802]	

Dimensions in mm [in]

Loading Information

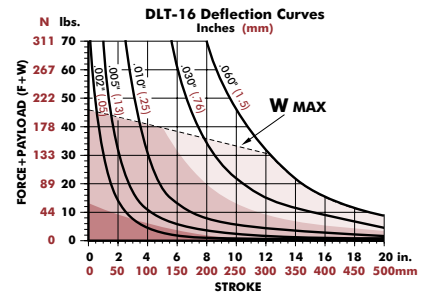
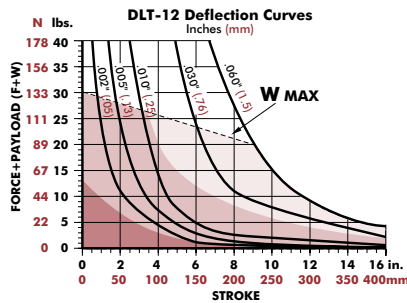
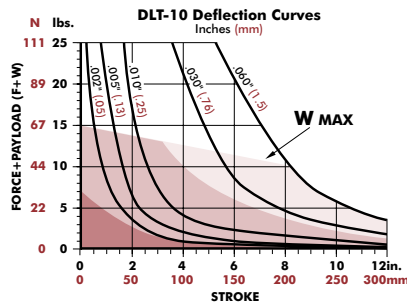

F=Externally applied force

W=Weight of payload

F+W=Total force

M=Maximum moment (in-lb. or N-m)

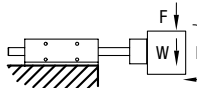

Shock Absorbers and Flow Controls are recommended for all applications

Use Double Shocks in both directions

Use Single Shock in both directions

Use Bumpers or Cushioned Cylinder

Shaded shock absorption ranges of horizontal payload (W) @ 80psi, flow controls fully open. For vertical applications do not exceed 1/2 of the recommended payload due to the additional acceleration effect of gravity.

External Air Cylinder Linear Thruster Slides | Dimensions and Technical Specifications

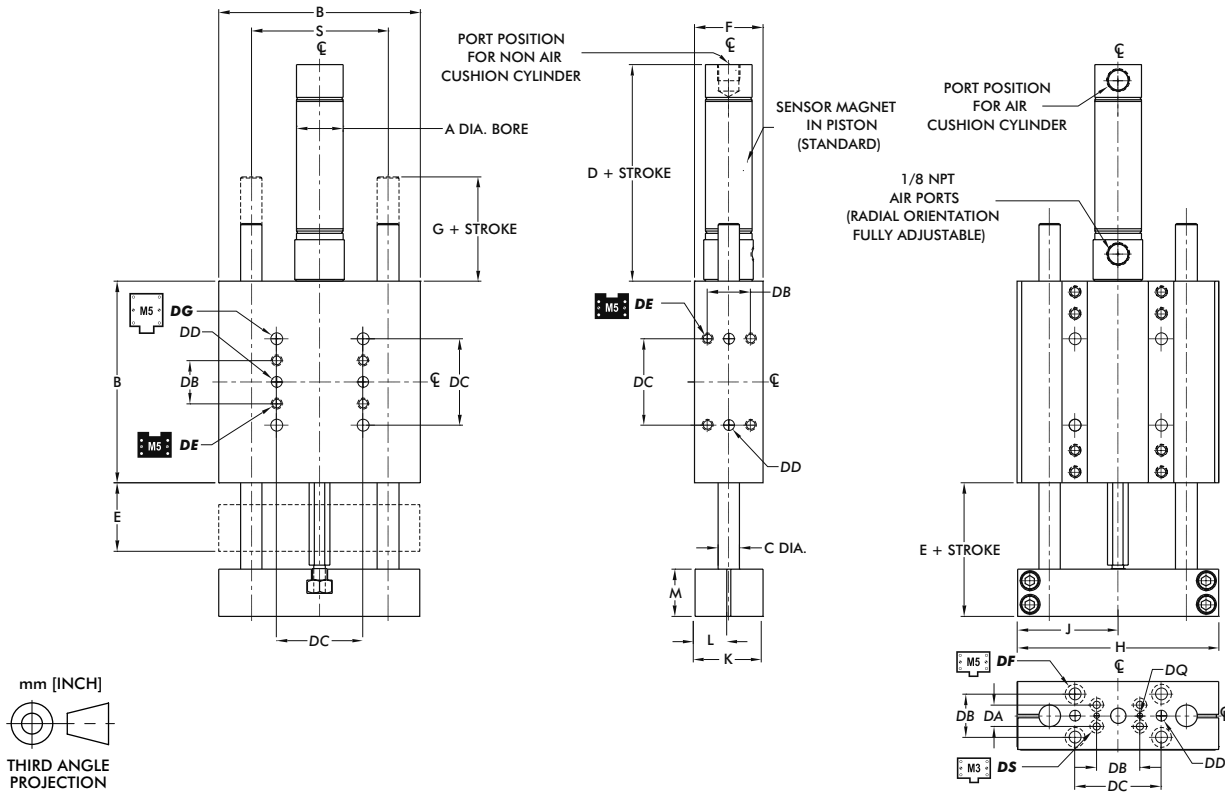

DIRECTCONNECT™ Mounting Pattern Dimensions (all sizes)

DA	DB	DC	DD	DE	DF	DG	DQ	DS
9.5 [0.375]	19.1 [0.750]	38.1 [1.500]	[0.1880 x 0.25 DP]	#[10-32 x .34 DP]	[CLR & C'BORE FOR #10]	[0.0940 x 0.078 DP]	[CLR & C'BORE FOR #4]	

Model	Bore Ø	Body Size	Shaft Ø	Basic Unit Dimensions													
				A	B	C	D	E	F	G	H	J	K	L	M	S	
DLB-10	19 [3/4]	88.9 [3.50]	9.5 [0.375]	87.4 [3.44]	33.4 [1.313]	30.2 [1.19]	20.8 [0.82]	88.6 [3.490]	44.2 [1.740]	29.9 [1.178]	14.8 [0.584]	20.7 [0.813]	60.33 [2.375]				
DLB-12	28.6 [1 1/8]	101.6 [4.00]	12.0 [0.472]			41.4 [1.63]								101.2 [3.985]	50.4 [1.985]	41.0 [1.615]	20.4 [0.802]
DLB-16		120.7 [4.75]	16.0 [0.630]			34.9 [1.375]	120.3 [4.735]							59.9 [2.360]	82.55 [3.250]		

Dimensions in mm [in]

Loading Information

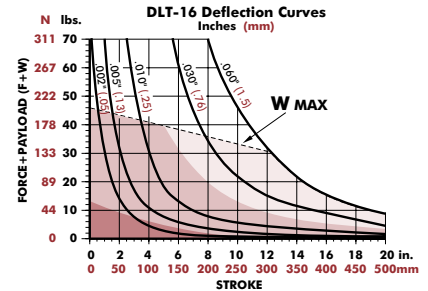
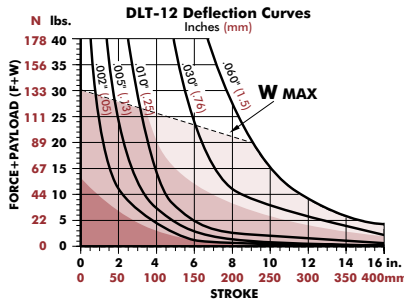
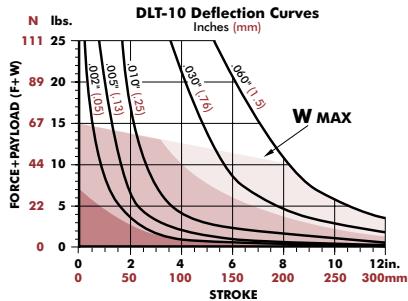

F=Externally applied force

W=Weight of payload

F+W=Total force

M=Maximum moment (in-lb. or N-m)

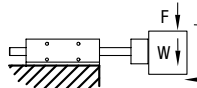

Shock Absorbers and Flow Controls are recommended for all applications

Use **Double Shocks** in both directions

Use **Single Shock** in both directions

Use **Bumpers or Cushioned Cylinder**

Shaded shock absorption ranges of horizontal payload (W) @ 80psi, flow controls fully open. For vertical applications do not exceed 1/2 of the recommended payload due to the additional acceleration effect of gravity.

DLT-20/25-T, A



External Air Cylinder Linear Thruster Slides | Dimensions and Technical Specifications

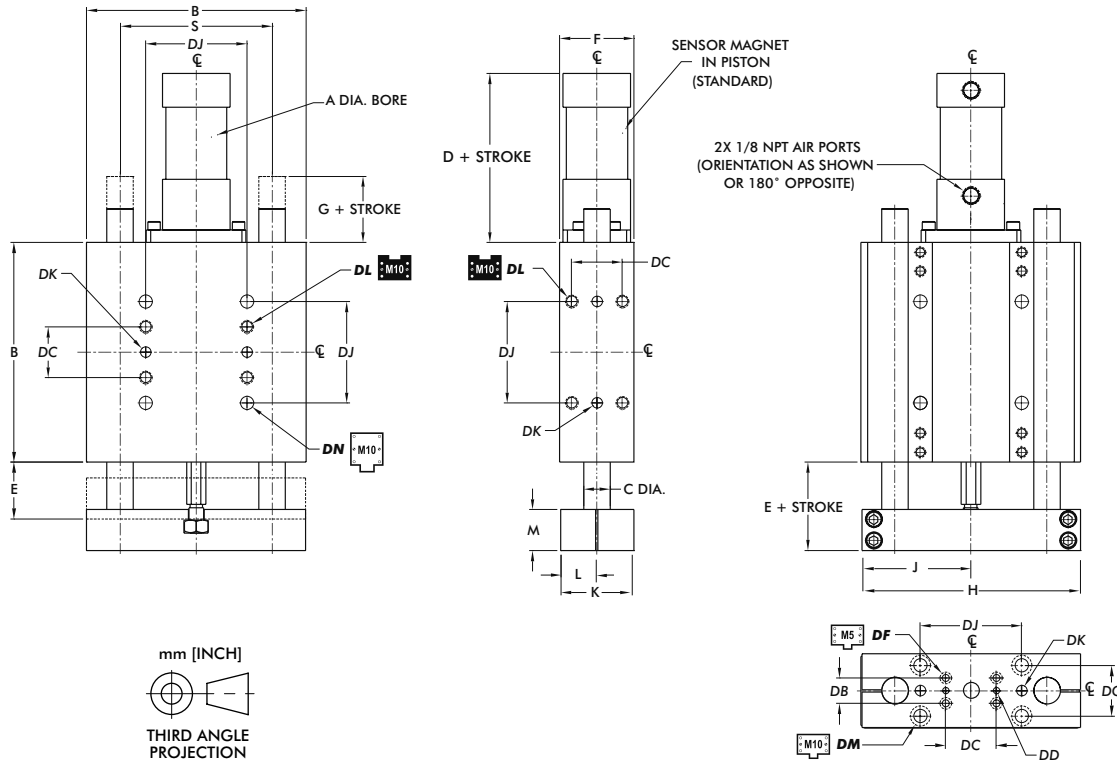

DIRECTCONNECT™ Mounting Pattern Dimensions (all sizes)

DB	DC	DD	DF	DJ	DK	DL	DM	DN
19.1 [0.750]	38.1 [1.500]	[0.1880 x 0.25 DP]	[CLR & C'BORE FOR #10]	76.2 [3.000]	[0.3130 x 0.37 DP]	[3/8 -16 x 0.56 DP]	[CLR & C'BORE FOR 3/8]	

Model	Bore Ø			Basic Unit Dimensions									
	A	B	C	D	E	F	G	H	J	K	L	M	S
DLB-20	38.1 [1 1/2]	165.1 [6.50]	20 [0.787]	76.2 [3.00]	49.8 [1.960]	55.9 [2.20]	24.4 [0.960]	164.6 [6.480]	82.0 [3.230]	55.4 [2.180]	27.4 [1.080]	30.7 [1.210]	114.30 [4.500]
DLB-25		190.5 [7.50]	25 [0.984]		55.1 [2.170]		29.7 [1.170]	190.0 [7.480]	94.7 [3.730]			36.1 [1.420]	133.35 [5.250]

Dimensions in mm [in]

Loading Information

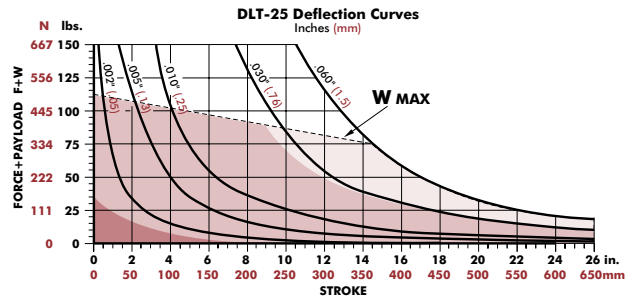
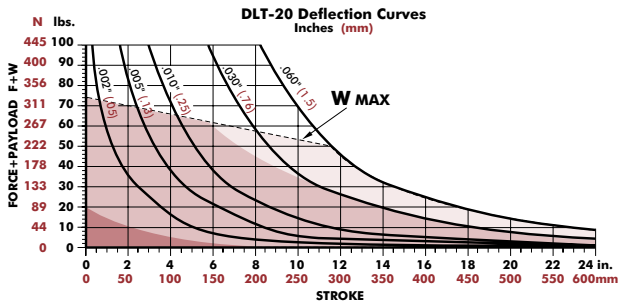

F=Externally applied force

W=Weight of payload

F+W=Total force

M=Maximum moment (in-lb. or N-m)

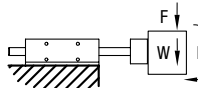

Shock Absorbers and Flow Controls are recommended for all applications

Use Double Shocks in both directions

Use Single Shock in both directions

Use Bumpers or Cushioned Cylinder

Shaded shock absorption ranges of horizontal payload (W) @ 80psi, flow controls fully open. For vertical applications do not exceed 1/2 of the recommended payload due to the additional acceleration effect of gravity.

External Air Cylinder Linear Thruster Slides | Dimensions and Technical Specifications

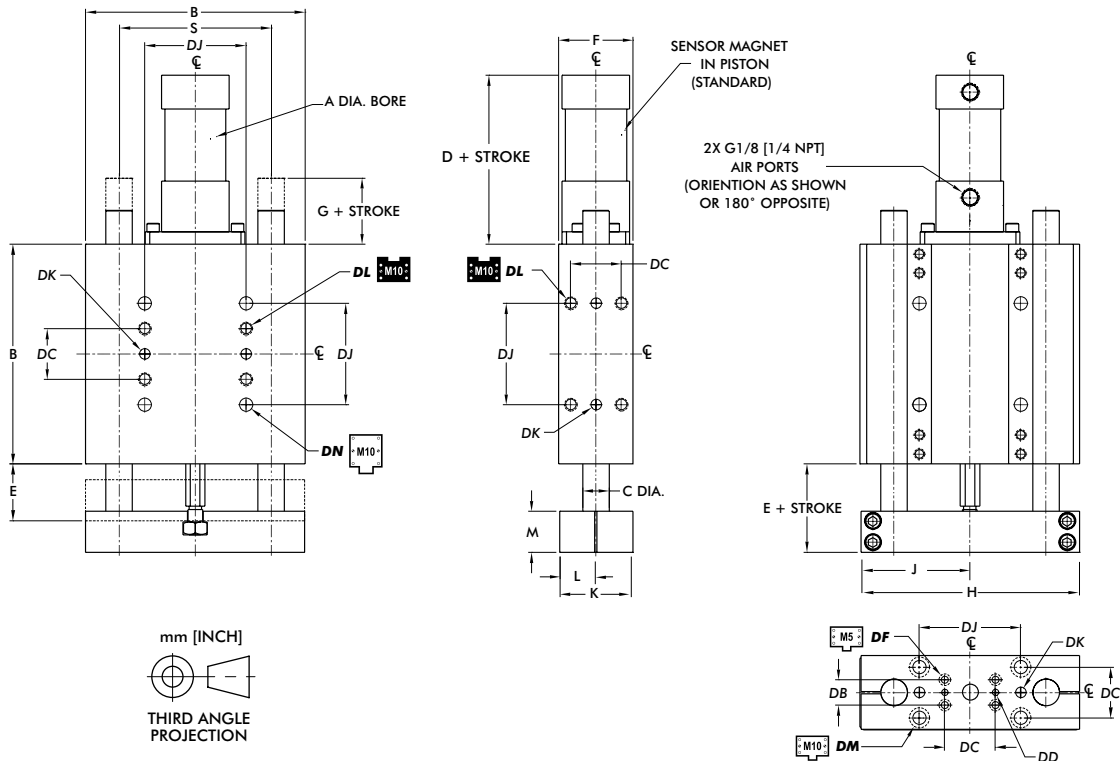

DIRECTCONNECT™ Mounting Pattern Dimensions (all sizes)									
DB	DC	DD	DF	DJ	DK	DL	DM	DN	
19.1 [0.750]	38.1 [1.500]	5mm H7 x 6 DP [0.1880 x 0.25 DP]	CLR & C'BORE FOR M5 [CLR & C'BORE FOR #10]	76.2 [3.000]	8mm H7 x 9.4 DP [0.3130 x 0.37 DP]	M10 x 14.2 DP [3/8 - 16 x 0.56 DP]	CLR & C'BORE FOR M10 [CLR & C'BORE FOR 3/8]		

Model	Bore Ø	Body Ø	Shaft Ø	Basic Unit Dimensions									
				A	B	C	D	E	F	G	H	J	K
DLB-20	32 [1 1/2]	165.1 [6.50]	20 [0.787]	107.7 [4.01]	49.8 [1.960]	55.9 [2.20]	24.4 [0.960]	164.6 [6.480]	82.0 [3.230]	55.4 [2.180]	27.4 [1.080]	30.7 [1.210]	114.30 [4.500]
DLB-25		190.5 [7.50]	25 [0.984]		55.1 [2.170]		29.7 [1.170]	190.0 [7.480]	94.7 [3.730]			36.1 [1.420]	133.35 [5.250]

Dimensions in mm [in]

Loading Information

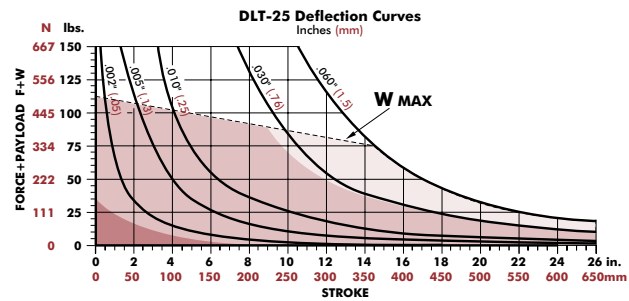
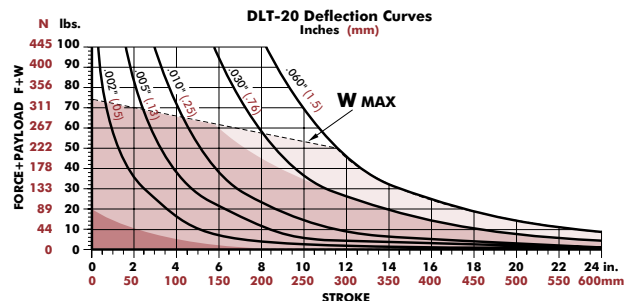

F=Externally applied force

W=Weight of payload

F+W=Total force

M=Maximum moment (in-lb. or N-m)

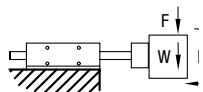

Shock Absorbers and Flow Controls are recommended for all applications

Use **Double Shocks** in both directions

Use **Single Shock** in both directions

Use **Bumpers or Cushioned Cylinder**

Shaded shock absorption ranges of horizontal payload (W) @ 80psi, flow controls fully open. For vertical applications do not exceed 1/2 of the recommended payload due to the additional acceleration effect of gravity.

BASE SLIDE ACCESSORIES

Linear Slides | Accessory Mounting Technical Data

DLB-B, L Internally Powered Base Slides

Shock Absorbers

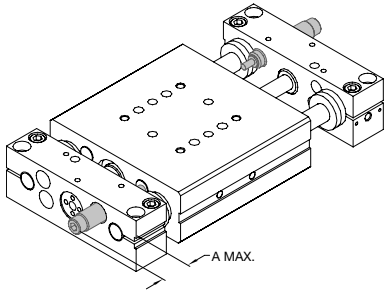

Adjustable Hard Stops

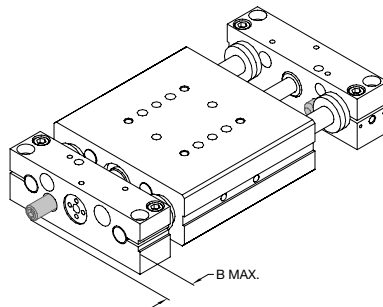

Inductive Proximity Sensors

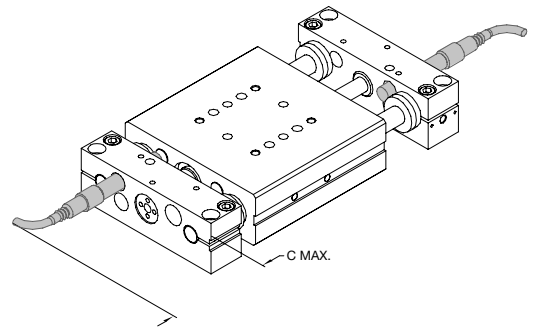

Telescopic Airlines

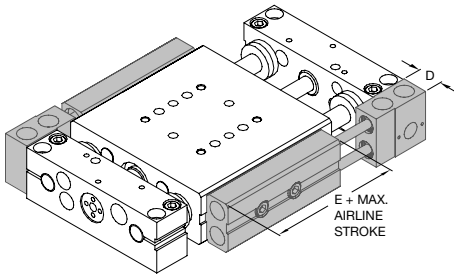

Flow Controls

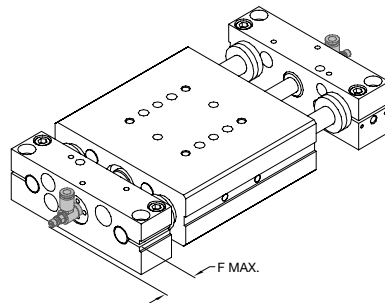

Model	A	B	C	D	E	F
DLB-06M	13.5 [0.53]	10.2 [0.40]	45.7 [1.8]	--	--	25.9 [1.02]
DLB-08M				--	--	
DLB-10	17.8 [0.70]					
DLB-12	24.1 [0.95]	11.9 [0.47]	63.5 [2.5]			
DLB-16				14.7 [0.577]	91.4 [3.60]	31.8 [1.25]
DLB-20	51.6 [2.03]		53.8 [2.1]			
DLB-25	46.2 [1.82]	2.5 [0.10]	48.3 [1.9]			

Dimensions in mm [in]

DLB-T, A, N Externally Powered Base Slides

Shock Absorbers

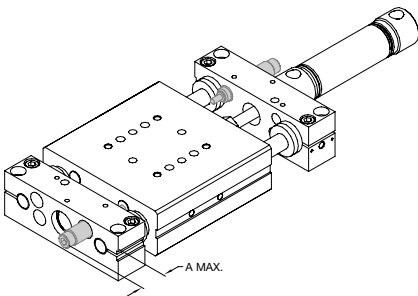

Adjustable Hard Stops

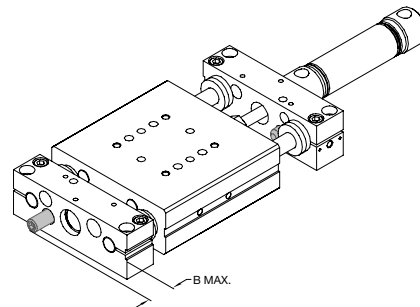

Telescoping Airlines & Flow Controls

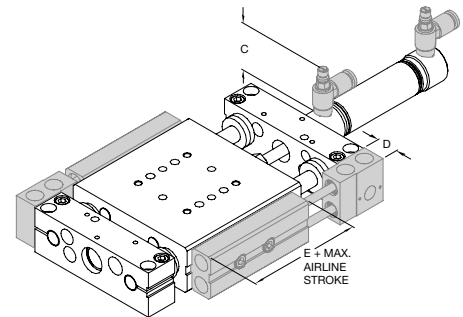

Inductive Proximity Sensors

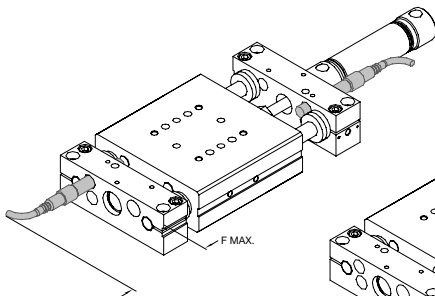

Magneto Resistive Sensors

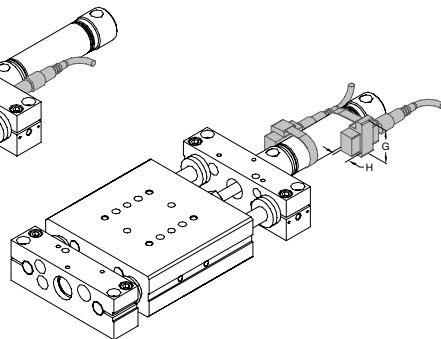

Model	A	B	C	D	E	F	G	H
DLB-06M	13.5 [0.53]	10.2 [0.40]	25.9 [1.02]	--	--	45.7 [1.8]		
DLB-08M				--	--			
DLB-10	17.8 [0.70]							
DLB-12	24.1 [0.95]	11.9 [0.47]				63.5 [2.5]	25.4 [1.00]	10.9 [0.43]
DLB-16			31.8 [1.25]	14.7 [0.577]	91.4 [3.60]			
DLB-20	51.6 [2.03]					53.8 [2.12]		
DLB-25	46.2 [1.82]	2.5 [0.10]				48.3 [1.90]		

Dimensions in mm [in]

LINEAR THRUSTER ACCESSORIES

Linear Slides | Accessory Mounting Technical Data

DLT-B, E, L Internally Powered Thruster Slides

Urethane Bumpers & Clamp Collars (DLT-E, L only)

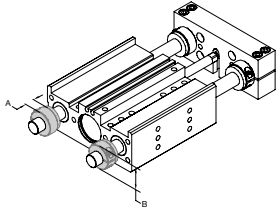

Adjustable Hard Stop & Shock Absorbers

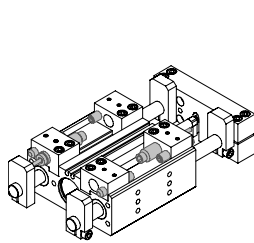

Universal Mounting Kit

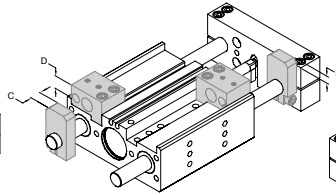

Telescoping Airlines (DLT-E, L only)

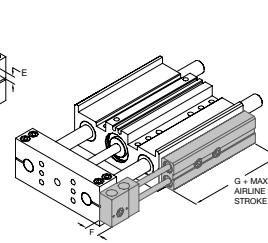

Base Flange Kit (DLT-B only)

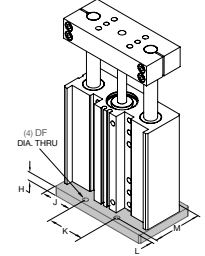

Inductive Proximity Sensors

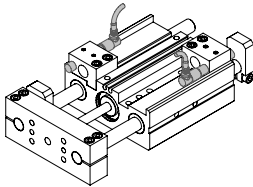

Magneto Resistive Sensors

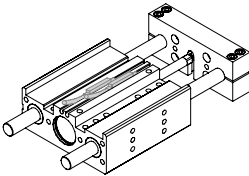

Model	A	B	C	D	E	F	G	H	J	K	L	M
DLT-06M	6.0 [0.236]	12 [0.470] 16 [0.630]	6.4 [0.250]	7.9 [0.310]	6.9 [0.270]	--	--	3.2 [0.125]	8.0 [0.313] 14.3 [0.563]	35 [1.376]	3.2 [0.125]	28.6 [1.125]
DLT-10	8.7 [0.343]	22.1 [0.87] 9.5 [0.375]	12.2 [0.480]	8.1 [0.320]	5.8 [0.230]			9.0 [0.355]	25.4 [1.000] 32.5 [1.281]	38.1 [1.500]	4.8 [0.188]	38.1 [1.500]
DLT-12	9.5 [0.375]	23.9 [0.95]	11.1 [0.437]	11.4 [0.450]	8.6 [0.340]	14.7 [0.577]	91.4 [3.60]		42.1 [1.656]			50.8 [2.000]
DLT-16	11.1 [0.437]	33.3 [1.31]	12.7 [0.500]	22.4 [0.920]	17.0 [0.67]			12.2 [0.480]	44.5 [1.750] 57.2 [2.250]	76.2 [3.000]	9.5 [0.375]	76.2 [3.000]
DLT-20	12.7 [0.500]	38.1 [1.50] 44.5 [1.75]										
DLT-25												

Dimensions in mm [in]

DLT-T, A, N Externally Powered Thruster Slides

Urethane Bumpers & Clamp Collars

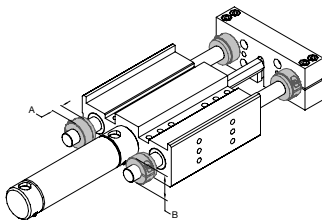

Adjustable Hard Stop & Shock Absorbers

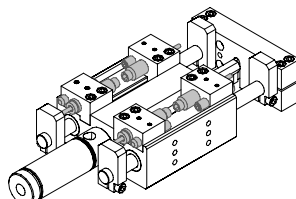

Universal Mounting Kit

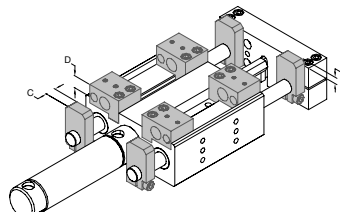

Telescoping Airlines & Flow Controls

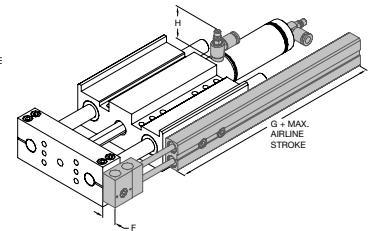

Inductive Proximity Sensors

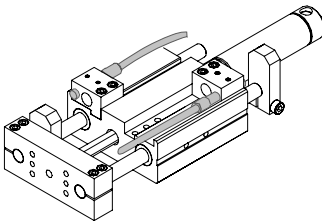

Magneto Resistive Sensors

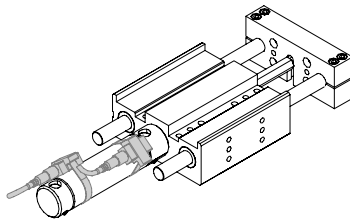

Model	A	B	C	D	E	F	G	H
DLT-06M	6.0 [0.236]	12.0 [0.47] 16.0 [0.63]	6.4 [0.250]	7.9 [0.31]	6.9 [0.27]	--	--	46.2 [1.82]
DLT-10	8.7 [0.343]	22.1 [0.87] 9.5 [0.375]	12.2 [0.480]	8.1 [0.320]	5.8 [0.230]			
DLT-12	9.5 [0.375]	23.9 [0.95]	11.1 [0.437]	11.4 [0.450]	8.6 [0.340]	14.7 [0.577]	91.4 [3.60]	28.4 [1.12]
DLT-16	11.1 [0.437]	33.3 [1.31]	12.7 [0.500]	23.4 [0.92]	17.0 [0.670]			
DLT-20	12.7 [0.500]	38.1 [1.50] 44.5 [1.75]						
DLT-25								

Dimensions in mm [in]

DLM SERIES

Miniature Rail Thruster Slide | Features and Benefits | How To Order

Features:

- Compact high reliability bearing design
- Excellent part position repeatability
- Double bearings -**D** for longer strokes, greater load and moment capacity
- Internal Delrin® extend and retract stops -**P** for increased repeatability
- Sense up to 8 positions with 4 adjustable magneto resistive sensors
- Multiple tapped air ports on each side, rear and bottom of body
- Thru-body mounting and DIRECTCONNECT™ thru tapped and dowel mounting, on tool plate and body
- Viton® seals for operation in high temperature environments

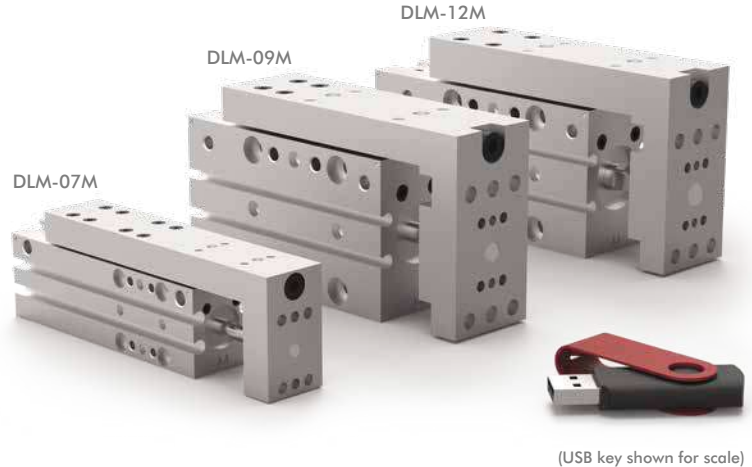

Applications:

- Precision applications
- Small parts handling

How To Order

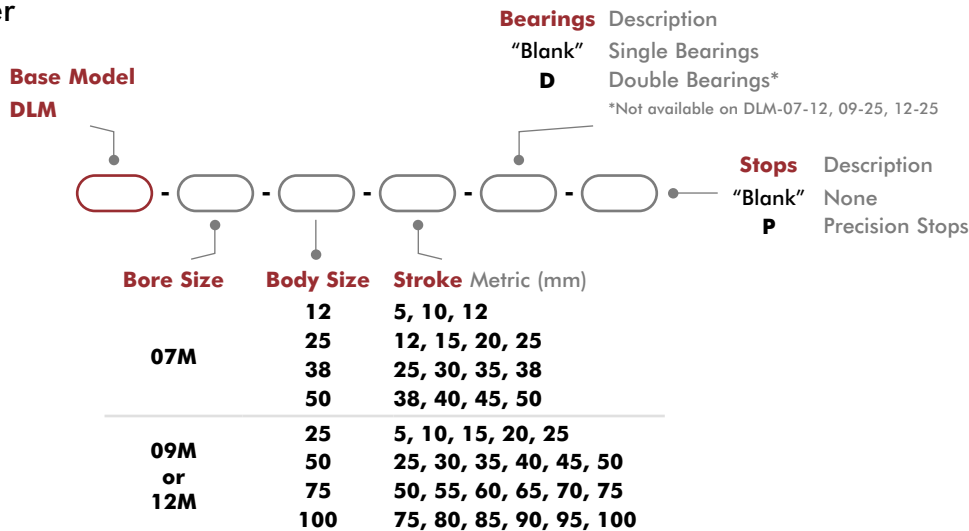

Accessories

Sensor Accessories	Model Numbers	Part Number	Qty/Unit
PNP Magneto Resistive Sensor Short Barrel (with Qk. Disc.)*	All Models	OHSP-017	1-4
NPN Magneto Resistive Sensor Short Barrel (with Qk. Disc.)*	All Models	OHSN-017	1-4
PNP Magneto Resistive Sensor 90° Barrel (with Qk. Disc.)*	All Models	OHSP-011	1-4
NPN Magneto Resistive Sensor 90° Barrel (with Qk. Disc.)*	All Models	OHSN-011	1-4
Quick Disconnect 2 Meter Cable Length*	All Models	CABL-010	1-4
Quick Disconnect 5 Meter Cable Length*	All Models	CABL-013	1-4

Pneumatic Accessories	Model Numbers	Part Number	Qty/Unit
Adjustable Flow Control	All Models	VLFL-008	1-2
Seal Kits	See Datasheets		1

* Sensor and cable sold separately.

Miniature Rail Thruster Slide | Technical Specifications

Specifications	Units	DLM-07M-12	DLM-07M-25	DLM-07M-38	DLM-07M-50
Thrust Force F @ 7 bar [100 psi]	N [lbs]	66 [15]			
Max. Stroke	mm [in]	12 [0.50]	25 [1.00]	38 [1.50]	50 [2.00]
Stroke Reduction (return)	mm [in]	5 [0.19]			
Weight	kg [lbs]	0.13 [0.28]	0.16 [0.35]	0.20 [0.43]	0.23 [0.50]
Max. Payload W	kg [lbs]	0.45 [1.0]			
Max. Payload W (-P option)	kg [lbs]	0.23 [0.5]			
Cylinder Bore \varnothing	mm [in]	0.11 [0.437]			
Temperature Range	°C [°F]	-35°~80° [-30°~180°]			
Actuation (per 25mm of travel)	sec	0.07			
Linear Accuracy (per 25mm of travel)	mm [in]	±0.005 [±0.0001]			
Repeatability (-P option)	mm [in]	±0.08 [±0.003]			
Pressure Range	bar [psi]	1.4-7 [20-100]			
Valve to Actuate Double Acting		4-way, 2-position			
Specifications	Units	DLM-09M-25	DLM-09M-50	DLM-09M-75	DLM-09M-100
Thrust Force F @ 7 bar [100 psi]	N [lbs]	138 N [31 lbs]			
Max. Stroke	mm [in]	25 [1.00]	50 [2.00]	75 [3.00]	100 [4.00]
Stroke Reduction (return)	mm [in]	5 [0.19]			
Weight	kg [lbs]	0.49 [1.08]	0.64 [1.41]	0.81 [1.78]	0.97 [2.13]
Max. Payload W	kg [lbs]	0.90 [2.0]			
Max. Payload W (-P option)	kg [lbs]	0.45 [1.0]			
Cylinder Bore \varnothing	mm [in]	16 [0.630]			
Temperature Range	°C [°F]	-35°~80° [-30°~180°]			
Actuation (per 25mm of travel)	sec	0.10			
Linear Accuracy (per 25mm of travel)	mm [in]	±0.005 [±0.0001]			
Repeatability (-P option)	mm [in]	±0.08 [±0.003]			
Pressure Range	bar [psi]	1.4-7 [20-100]			
Valve to Actuate Double Acting		4-way, 2-position			
Specifications	Units	DLM-12M-25	DLM-12M-50	DLM-12M-75	DLM-12M-100
Thrust Force F @ 7 bar [100 psi]	N [lbs]	230 [51]			
Max. Stroke	mm [in]	25 [1.00]	50 [2.00]	75 [3.00]	100 [4.00]
Stroke Reduction (return)	mm [in]	5 [0.19]			
Weight	kg [lbs]	0.54 [1.18]	0.65 [1.43]	1.82 [1.80]	1.02 [2.25]
Max. Payload W	kg [lbs]	1.81 [4.0]			
Max. Payload W (-P option)	kg [lbs]	0.90 [2.0]			
Cylinder Bore \varnothing	mm [in]	22 [0.813]			
Temperature Range	°C [°F]	-35°~80° [-30°~180°]			
Actuation (per 25mm of travel)	sec	0.14			
Linear Accuracy (per 25mm of travel)	mm [in]	±0.005 [±0.0001]			
Repeatability (-P option)	mm [in]	±0.08 [±0.003]			
Pressure Range	bar [psi]	1.4-7 [20-100]			
Valve to Actuate Double Acting		4-way, 2-position			



Miniature Rail Thruster Slide | Dimensions and Technical Specifications

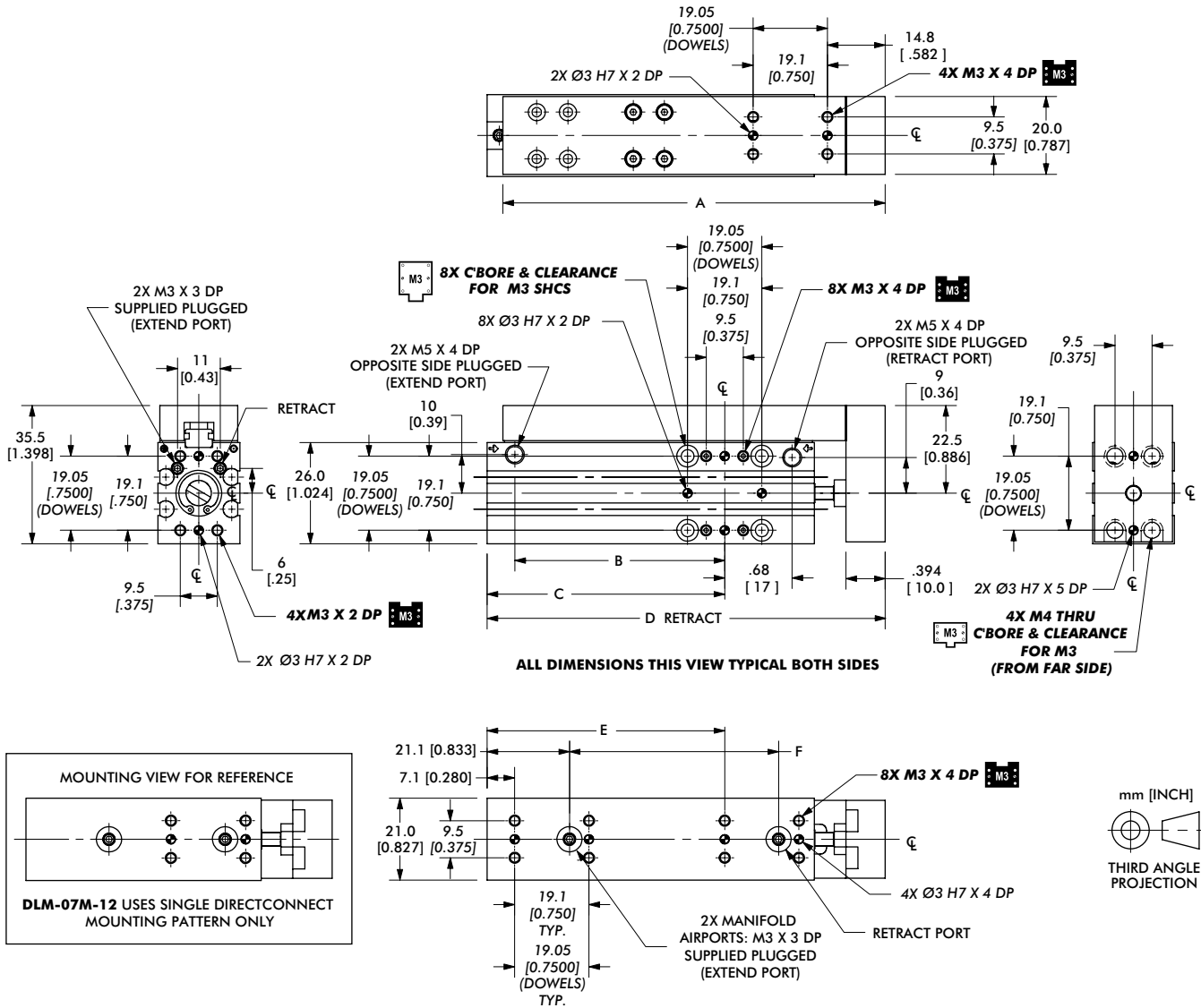

Seal Repair Kits	Order #
Buna-N Seal Repair Kit	SLKT-236
Manifold Seal Repair Kit	SLKT-239

Model	A	B	C	D	E	F	L (single bearing)	L (double bearing)
DLM-07M-12	66.0 [2.599]	30 [1.18]	37.0 [1.456]	78 [3.08]	37.0 [1.456]	29.6 [1.167]	53 [2.10]	--
DLM-07M-25	98.0 [3.859]	54 [2.12]	61.0 [2.401]	102 [4.02]	60.9 [2.401]	53.6 [2.112]	61 [2.39]	73 [2.87]
DLM-07M-38	111.0 [4.370]	67 [2.63]	74.0 [2.913]	115 [4.53]	74.0 [2.913]	66.6 [2.624]	74 [2.90]	86 [3.38]
DLM-07M-50	123.0 [4.843]	79 [3.10]	86.0 [3.385]	127 [5.00]	86.0 [3.385]	78.6 [3.096]	86 [3.37]	98 [3.86]

Dimensions in mm [in]

Loading Information

Forces shown for single bearing units. Values 2X for double bearings -D option.

DLM-07	Static
Maximum Tensile T	490 N [110 lbs]
Maximum Compressive C	490 N [110 lbs]
Maximum Moment M_x	5.1 Nm [45 in-lbs]
Maximum Moment M_y	3.2 Nm [28 in-lbs]
Maximum Payload W	3.2 Nm [28 in-lbs]
Distance to Bearing Centerline	L (see chart above)

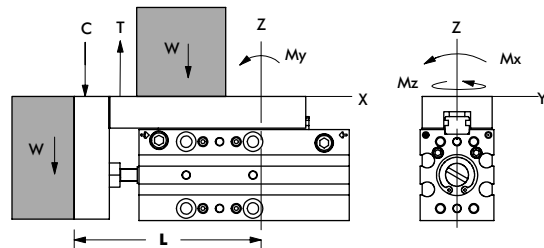

Flow Controls are recommended for all applications

Miniature Rail Thruster Slide | Dimensions and Technical Specifications

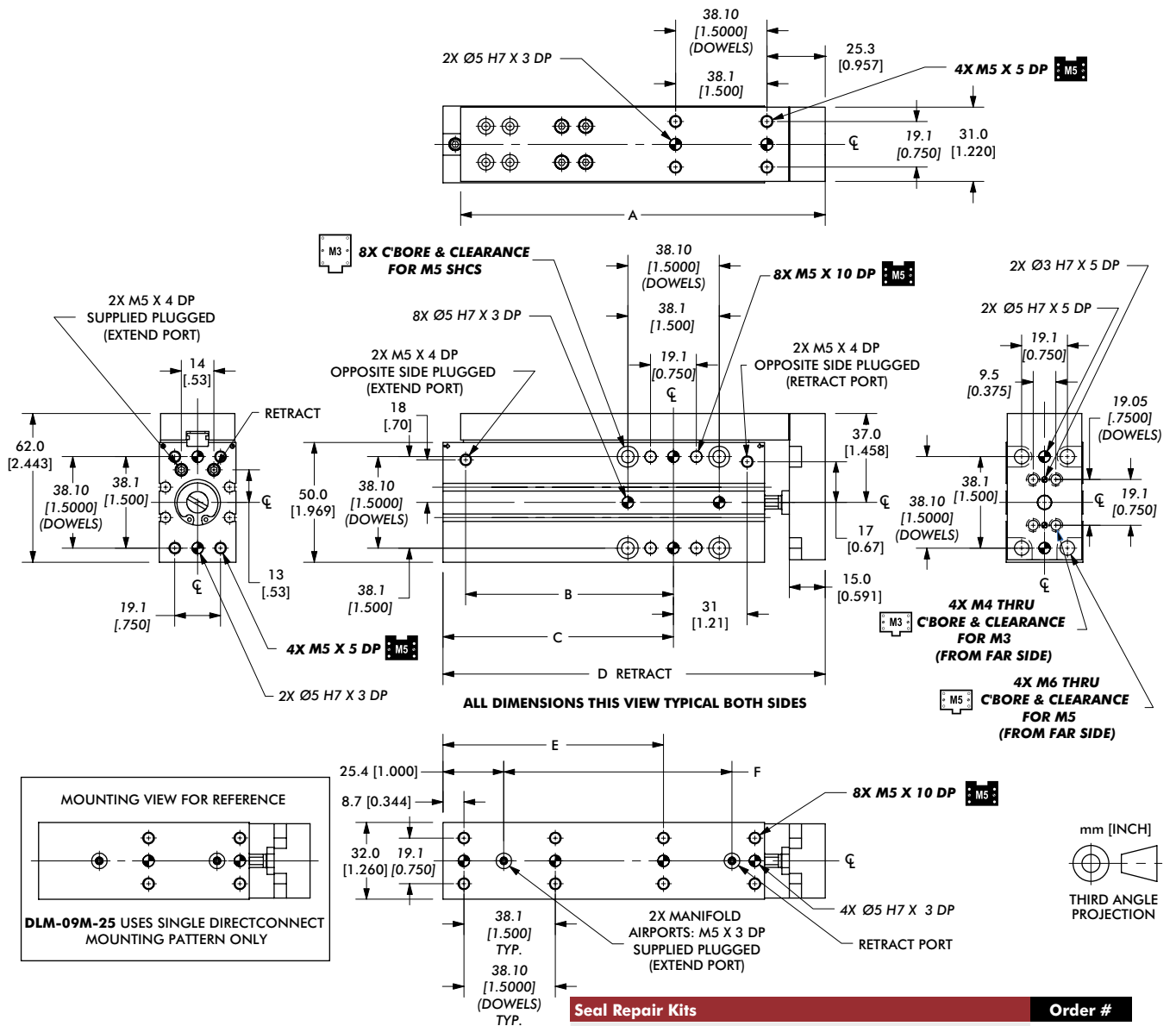

Model	A	B	C	D	E	F	L (single bearing)	L (double bearing)
DLM-09M-25	102.0 [4.016]	41 [1.60]	50.1 [1.973]	113 [4.46]	45.9 [1.809]	49.1 [1.934]	86 [3.40]	--
DLM-09M-50	152.0 [5.985]	87 [3.41]	96.1 [3.784]	159 [6.27]	91.9 [3.620]	95.1 [3.745]	105 [4.13]	121 [4.75]
DLM-09M-75	173.0 [6.811]	112 [4.39]	121.1 [4.768]	184 [7.26]	116.9 [4.604]	120.1 [4.729]	126 [4.95]	142 [5.58]
DLM-09M-100	202.0 [7.953]	137 [5.38]	146.1 [5.752]	209 [8.24]	138.9 [5.557]	145.1 [5.713]	155 [6.10]	171 [6.72]

Dimensions in mm [in]

Loading Information

Forces shown for single bearing units. Values 2X for double bearings -D option.

DLM-09	Static
Maximum Tensile T	735 N [165 lbs]
Maximum Compressive C	735 N [165 lbs]
Maximum Moment M_x	9.6 Nm [84 in-lbs]
Maximum Moment M_y	6.4 Nm [56 in-lbs]
Maximum Payload W	6.4 Nm [56 in-lbs]
Distance to Bearing Centerline	L (see chart above)

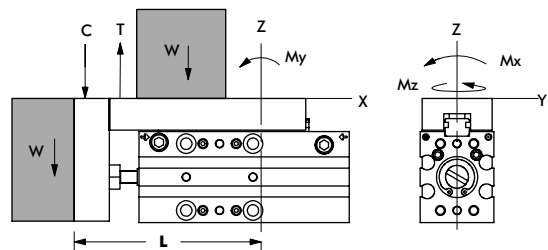

Flow Controls are recommended for all applications

Miniature Rail Thruster Slide | Dimensions and Technical Specifications

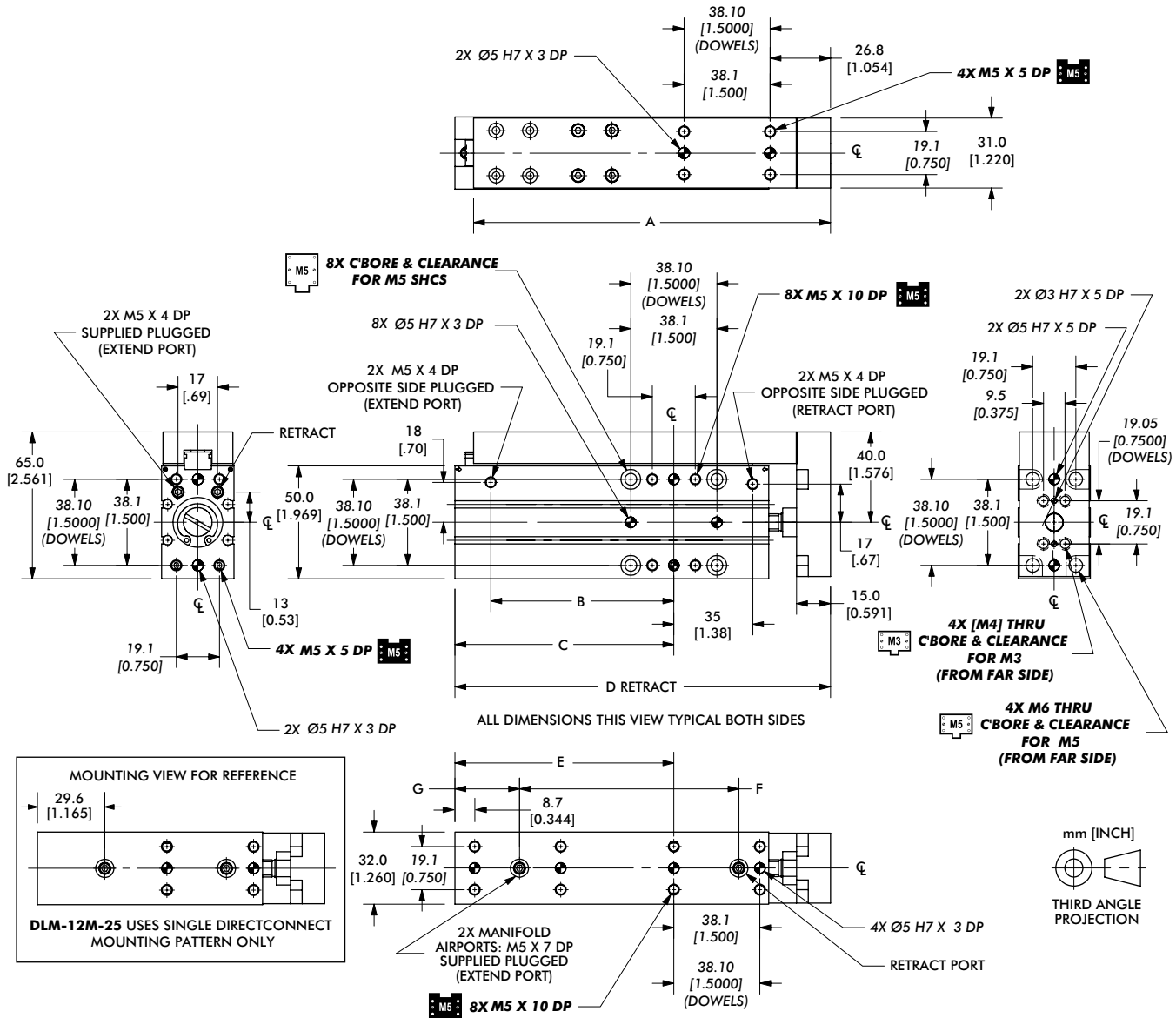

Seal Repair Kits	Order #
Buna-N Seal Repair Kit	SLKT-238
Manifold Seal Repair Kit	SLKT-240

Model	A	B	C	D	E	F	G	L (single bearing)	L (double bearing)
DLM-12M-25	105.0 [4.134]	41 [1.62]	56.9 [2.242]	126 [4.97]	56.9 [2.242]	53.5 [2.108]	29.6 [1.165]	88 [3.45]	--
DLM-12M-50	158.0 [6.221]	81 [3.19]	96.9 [3.816]	166 [6.55]	96.9 [3.816]	97.1 [3.824]		104 [4.10]	122 [4.82]
DLM-12M-75	186.0 [7.323]	108 [4.25]	123.9 [4.879]	193 [7.61]	123.9 [4.879]	124.1 [4.887]	28.6 [1.125]	132 [5.21]	150 [5.92]
DLM-12M-100	208.0 [8.189]	133 [5.24]	148.9 [5.864]	218 [8.60]	148.9 [5.864]	149.1 [5.872]		154 [6.07]	172 [6.79]

Dimensions in mm [in]

Loading Information

Forces shown for single bearing units. Values 2X for double bearings -D option.

DLM-12M	Static
Maximum Tensile T	1214 N [273 lbs]
Maximum Compressive C	1214 N [273 lbs]
Maximum Moment M_x	20.6 Nm [182 in-lbs]
Maximum Moment M_y	11.8 Nm [104 in-lbs]
Maximum Payload W	11.8 Nm [104 in-lbs]
Distance to Bearing Centerline	L (see chart above)

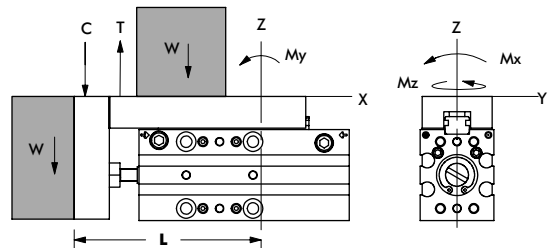

Flow Controls are recommended for all applications

MPS SERIES

Miniature Rail Thruster Slide | Features and Benefits | How To Order

Features:

- Compact high reliability bearing design
- Excellent part position repeatability
- Zero side play with patented preloaded "Dual-V" roller bearings
- Adjustable extend/retract hard stops
- Two Position sensing with hall effect sensors
- Viton® seals for operation in high temperature environments

Applications:

- Precision applications
- Small parts handling
- OEM packaging machines

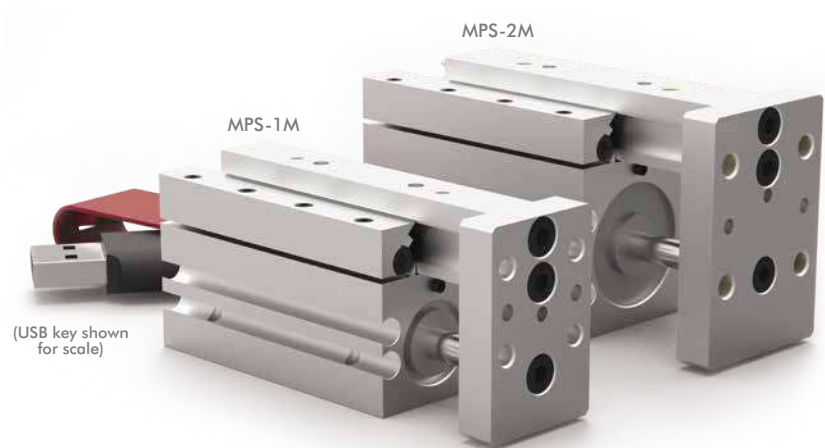

How To Order

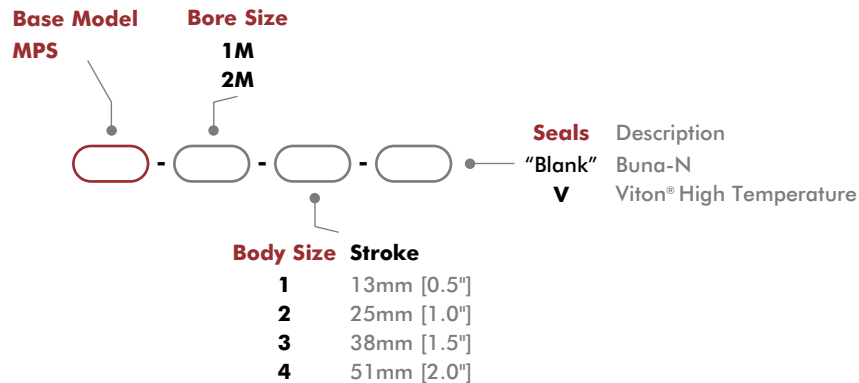

Accessories

Sensor Accessories	Model Numbers	Part Number	Qty/Unit
Magneto Resistive Sensor with Quick. Disconnect*	All Models	OHSN-006	1-2
Magneto Resistive Sensor with Quick. Disconnect*		OHSP-006	
Quick Disconnect 2 Meter Cable Length*		CABL-010	
Quick Disconnect 5 Meter Cable Length*		CABL-013	
Pneumatic Accessories	Model Numbers	Part Number	Qty/Unit
M5 Adjustable Flow Control	All Models	VLVF-008	1-2
M2.5 Barbed Fitting		PLFT-005	2
Seal Kit (Buna-N)	-1M	SLKT-090	1
Seal Kit (Viton®)	-1M	SLKT-090V	
Seal Kit (Buna-N)	-2M	SLKT-091	
Seal Kit (Viton®)	-2M	SLKT-091V	

* Sensor and cable sold separately.

Miniature Rail Thruster Slide | Technical Specifications

Specifications	Units	1M-1	1M-2	1M-3	1M-4
Thrust Force F @ 7 bar [100 psi]	N [lbs]	67 [15]			
Max. Stroke	mm [in]	13 [0.50]	25 [1.00]	38 [1.50]	51 [2.00]
Stroke Adjustability (each end)	mm [in]	3 [0.12]		6 [0.25]	
Weight	kg [lb]	0.08 [0.18]	0.10 [0.22]	0.13 [0.28]	0.14 [0.32]
Max. Payload W	kg [lb]	0.14 [0.30]	0.32 [0.70]	0.45 [1.00]	0.59 [1.30]
Pressure Range	bar [psi]	1.5-7 [20-100]			
Cylinder Bore \varnothing	mm [in]	11.1 [0.438]			
Temperature Range (Buna-N seals)	°C [°F]	-35°~80° [-30°~180°]			
Temperature Range (Viton® seals)	°C [°F]	-30°~120° [-20°~250°]			
Actuation	sec	0.10	0.11	0.13	0.14
Linear Accuracy (per 25mm of travel)	mm [in]	±0.003 [±0.0001]			
Repeatability (-P option)	mm [in]	±0.03 [±0.010]			
Valve to Actuate Double Acting		4-way, 2-position			

Specifications	Units	2M-1	2M-2	2M-3	2M-4
Thrust Force F @ 7 bar [100 psi]	N [lbs]	196 [44]			
Max. Stroke	mm [in]	13 [0.50]	25 [1.00]	38 [1.50]	51 [2.00]
Stroke Adjustability (each end)	mm [in]	3 [0.12]		6 [0.25]	
Weight	kg [lb]	0.12 [0.26]	0.14 [0.32]	0.18 [0.40]	0.21 [0.46]
Max. Payload W	kg [lb]	0.23 [0.50]	0.45 [1.00]	0.91 [2.00]	1.36 [3.00]
Pressure Range	bar [psi]	1.5-7 [20-100]			
Cylinder Bore \varnothing	mm [in]	19.1 [0.750]			
Temperature Range (Buna-N seals)	°C [°F]	-35°~80° [-30°~180°]			
Temperature Range (Viton® seals)	°C [°F]	-30°~120° [-20°~250°]			
Actuation	sec	0.12	0.16	0.19	0.24
Linear Accuracy (per 25mm of travel)	mm [in]	±0.003 [±0.0001]			
Repeatability (-P option)	mm [in]	±0.03 [±0.010]			
Valve to Actuate Double Acting		4-way, 2-position			

MPS-1M

Miniature Rail Thruster Slide | Dimensions and Technical Specifications

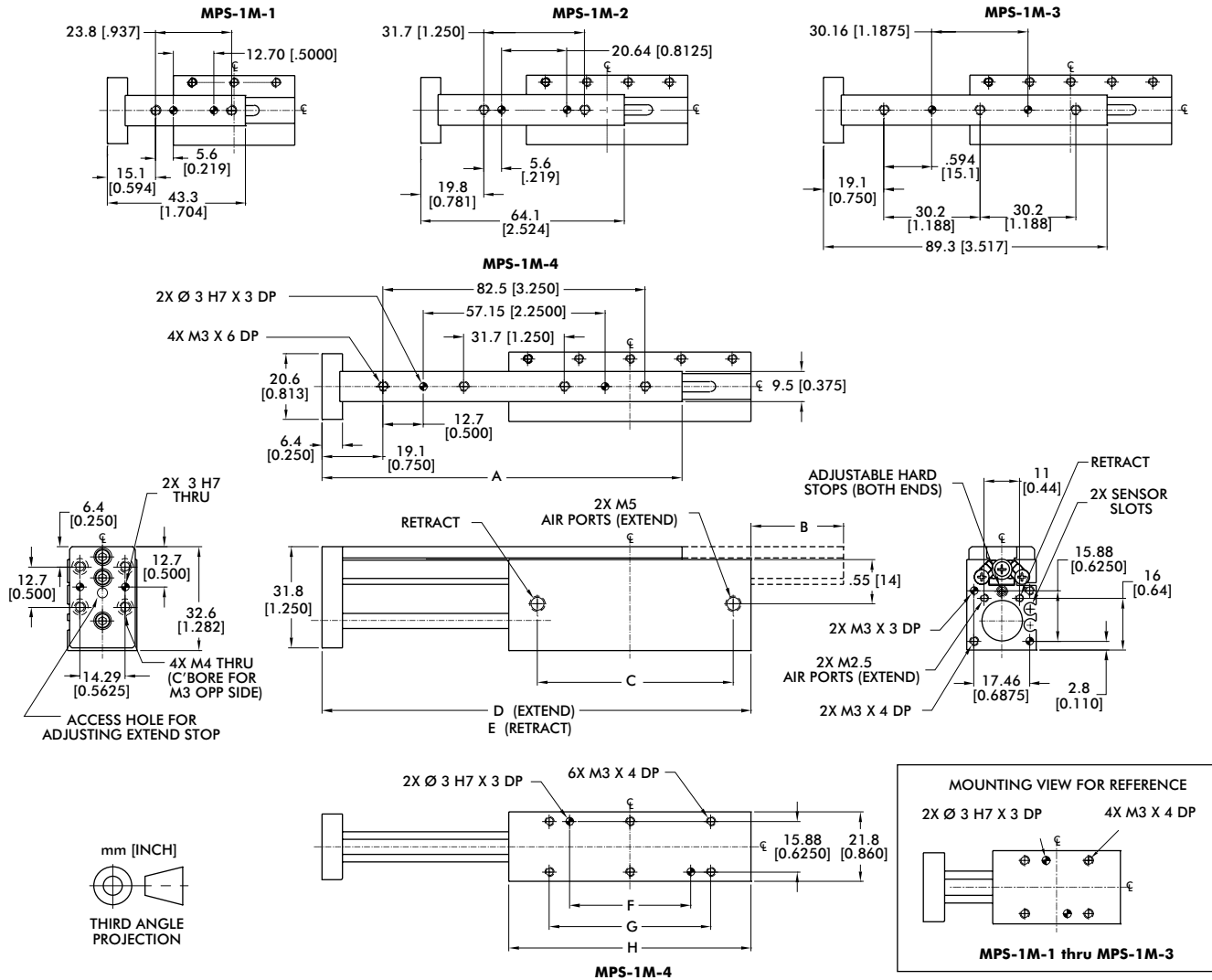

Model	A	B	C	D	E	F	G	H
MPS-1M-1	43.3 [1.704]	--	23 [0.92]	59 [2.31]	46 [1.81]	6.35 [0.2500]	19.1 [0.750]	38.1 [1.500]
MPS-1M-2	64.1 [2.524]	5.4 [0.211]	36 [1.43]	84 [3.31]	58 [2.31]	19.05 [0.7500]	31.8 [1.250]	50.8 [2.000]
MPS-1M-3	89.3 [3.517]	17.9 [0.704]	49 [1.93]	110 [4.31]	71 [2.81]	25.40 [1.0000]	38.1 [1.500]	63.5 [2.500]
MPS-1M-4	113.1 [4.454]	29.0 [1.141]	62 [2.43]	135 [5.31]	84 [3.31]	38.10 [1.5000]	50.8 [2.000]	76.2 [3.000]

Dimensions in mm [in]

Loading Information

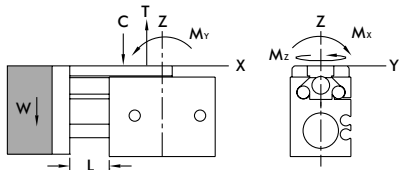

Model	Static	Model	Static
MPS-1M-1	Maximum Tensile T 111 N [25 lbs] Maximum Compressive C 111 N [25 lbs] Maximum Moment M_x 3.4 Nm [30 in-lbs] Maximum Moment M_y 2.3 Nm [20 in-lbs] Maximum Moment M_z 2.3 Nm [20 in-lbs]	MPS-1M-3	Maximum Tensile T 222 N [50 lbs] Maximum Compressive C 222 N [50 lbs] Maximum Moment M_x 6.8 Nm [60 in-lbs] Maximum Moment M_y 4.5 Nm [40 in-lbs] Maximum Moment M_z 4.5 Nm [40 in-lbs]
MPS-1M-2	Maximum Tensile T 156 N [35 lbs] Maximum Compressive C 156 N [35 lbs] Maximum Moment M_x 4.5 Nm [40 in-lbs] Maximum Moment M_y 3.4 Nm [30 in-lbs] Maximum Moment M_z 3.4 Nm [30 in-lbs]	MPS-1M-4	Maximum Tensile T 311 N [70 lbs] Maximum Compressive C 311 N [70 lbs] Maximum Moment M_x 9.0 Nm [80 in-lbs] Maximum Moment M_y 5.7 Nm [50 in-lbs] Maximum Moment M_z 5.7 Nm [50 in-lbs]

Miniature Rail Thruster Slide | Dimensions and Technical Specifications

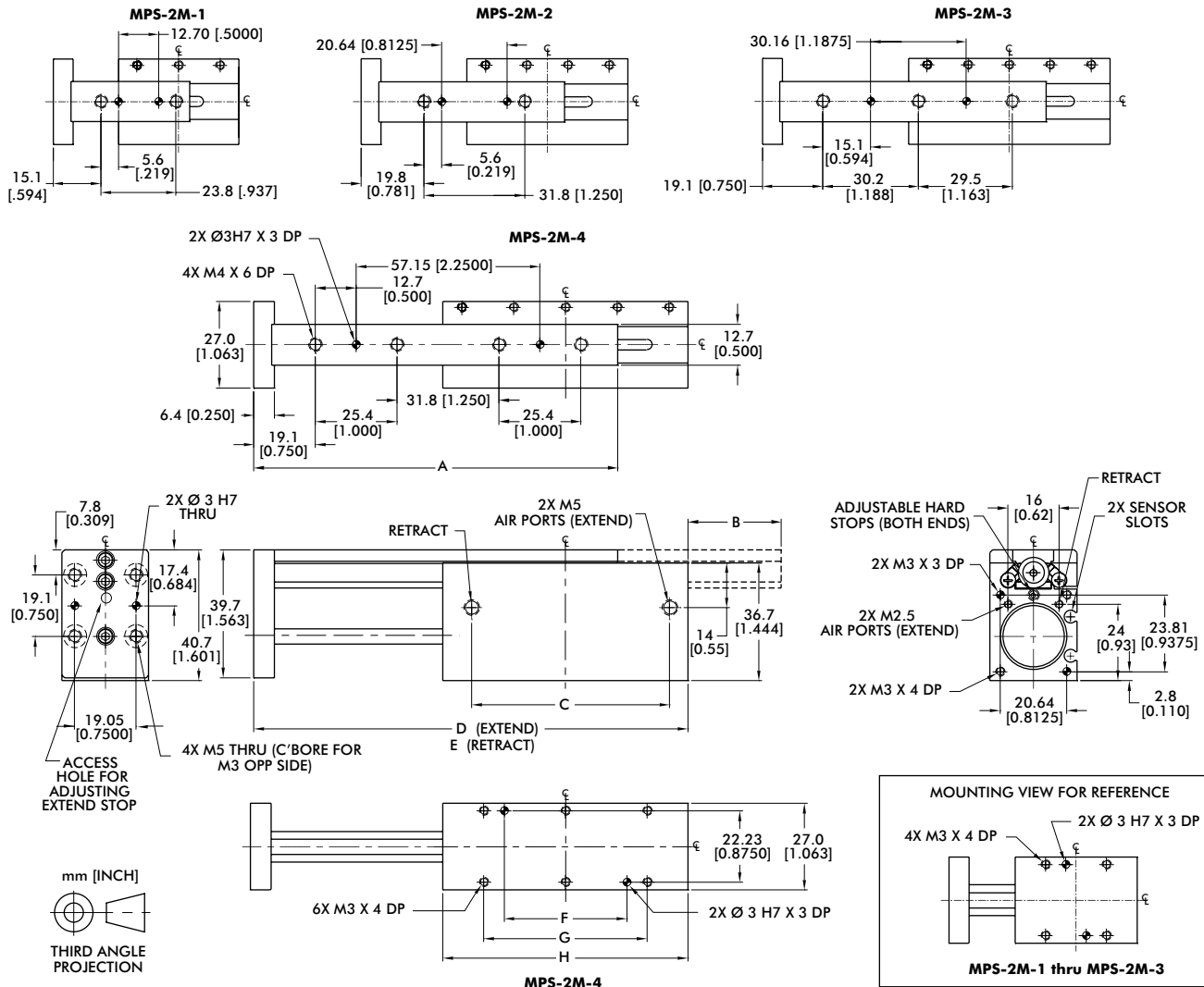

Model	A	B	C	D	E	F	G	H
MPS-2M-1	43.3 [1.704]	--	23 [0.92]	59 [2.31]	46 [1.81]	6.35 [0.2500]	19.1 [0.750]	38.1 [1.500]
MPS-2M-2	64.1 [2.524]	5.4 [0.211]	36 [1.43]	84 [3.31]	59 [2.31]	19.05 [0.7500]	31.7 [1.250]	50.8 [2.000]
MPS-2M-3	89.5 [3.524]	17.9 [0.704]	49 [1.92]	110 [4.31]	71 [2.81]	25.40 [1.0000]	38.1 [1.500]	63.5 [2.500]
MPS-2M-4	113.1 [4.454]	29.0 [1.141]	62 [2.42]	135 [5.31]	84 [3.31]	38.10 [1.5000]	50.8 [2.000]	76.2 [3.000]

Dimensions in mm [in]

Loading Information

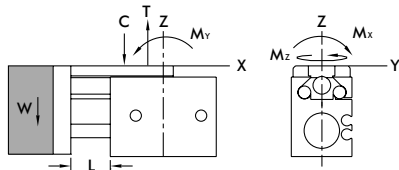

MPS-2M-1	Static
Maximum Tensile T	111 N [25 lbs]
Maximum Compressive C	111 N [25 lbs]
Maximum Moment M_x	3.4 Nm [30 in-lbs]
Maximum Moment M_y	2.3 Nm [20 in-lbs]
Maximum Moment M_z	2.3 Nm [20 in-lbs]



MPS-2M-3	Static
Maximum Tensile T	222 N [50 lbs]
Maximum Compressive C	222 N [50 lbs]
Maximum Moment M_x	6.8 Nm [60 in-lbs]
Maximum Moment M_y	4.5 Nm [40 in-lbs]
Maximum Moment M_z	4.5 Nm [40 in-lbs]

MPS-2M-2	Static
Maximum Tensile T	156 N [35 lbs]
Maximum Compressive C	156 N [35 lbs]
Maximum Moment M_x	4.5 Nm [40 in-lbs]
Maximum Moment M_y	3.4 Nm [30 in-lbs]
Maximum Moment M_z	3.4 Nm [30 in-lbs]

MPS-2M-4	Static
Maximum Tensile T	311 N [70 lbs]
Maximum Compressive C	311 N [70 lbs]
Maximum Moment M_x	9.0 Nm [80 in-lbs]
Maximum Moment M_y	5.7 Nm [50 in-lbs]
Maximum Moment M_z	5.7 Nm [50 in-lbs]

FEED ESCAPEMENTS

Grippers, Rotates, and Linear Slide Solutions

	Model	Stroke Range	Thrust Range	Operating Environment	Special Features	Page GR-ESC-#
RFE		16-32mm [0.625-1.25 in]	111N - 400 N [25 lbs - 90 lbs]	IP54	Conveying part accumulator, part separator and staging. Failsafe finger locking	3
RN		16-32mm [0.625-1.25 in]	111N - 400 N [25 lbs - 90 lbs]	IP54	In-line part ejector and part staging. Conveying part accumulator or part separator.	7

FEED ESCAPEMENTS

Product Overview



Global Automation Solutions

DESTACO's Robohand products are engineered for reliability and long life to ensure maximum production uptime. These products are designed and machined for precise repeatability with minimal maintenance.



destaco.com

End Effectors | Grippers | Indexers | Manual Clamps | Power Clamps | Remote Handling

RFE SERIES

Feed Escapements | Features and Benefits | How To Order | Technical Specifications

Features:

- Sequential Part feeding with automatic finger locking mechanism
- Non-rotating square shaft maintains proper finger alignment
- Sealed design with adjustable retract stops
- Only one finger can be retracted at any time
- Unit can be mounted using top, bottom or face surface

Applications:

- Part separation, part staging
- Conveying timing operations

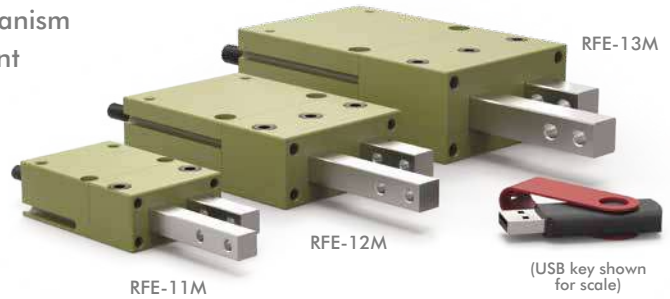

How To Order

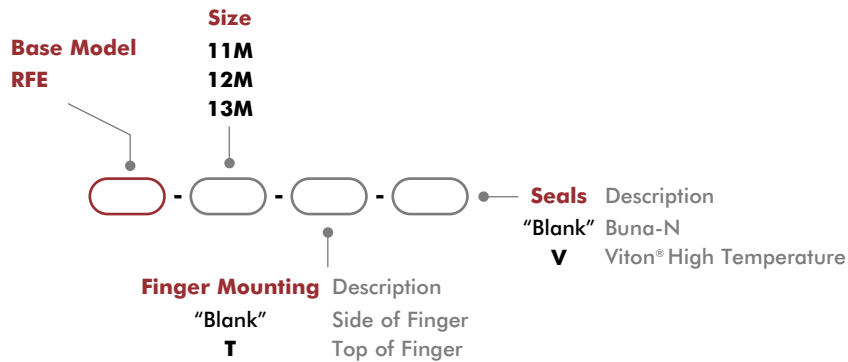

Accessories

Sensor Accessories	Model Numbers	Part Number	Qty/Unit
NPN Hall Effect Sensor with Quick Disconnect*	All Models	OHSN-017	1-2
PNP Hall Effect Sensor with Quick Disconnect*	All Models	OHSP-017	1-2
Quick Disconnect 2 Meter Cable Length*	All Models	CABL-010	1-2
Quick Disconnect 5 Meter Cable Length*	All Models	CABL-013	1-2

Pneumatic Accessories	Model Numbers	Part Number	Qty/Unit
M5 Adjustable Flow Control	All Models	VLVF-008	1-2

*Sensor and cable sold separately.

Specifications

Specifications	Units	11M	12M	13M
Thrust Force @ Maximum PSI	N [lbs]	111 [25]	222 [50]	400 [90]
Stroke	mm [in]	15.88 [0.625]	25.40 [1.000]	31.75 [1.250]
Stroke Adjustability	mm [in]	11 [0.44]	19 [0.75]	19 [0.75]
Weight	kg [lb]	0.15 [0.33]	0.39 [0.85]	0.83 [1.84]
Pressure Range	bar [psi]	3-7 [40-100]		
Cylinder Bore Ø	mm [in]	14.30 [0.563]	20 [0.787]	27 [1.063]
Rod Ø	mm [in]	6.35 [0.250]	7.95 [0.313]	9.52 [0.375]
Displacement	cm ³ [in ³]	2.6 [0.156]	8.0 [0.487]	18.2 [1.108]
Temperature Range (Buna-N seals)	°C [°F]	-35~80° [-30~180°]		
Temperature Range (Viton® seals)	°C [°F]	-30~150° [-20~300°]		
Actuation	sec	0.40	0.60	0.70
Parts Escaped per Minute		150	100	85
Valve to Actuate		4-way, 2-position		

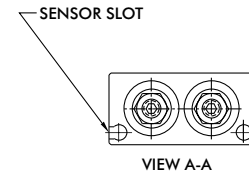
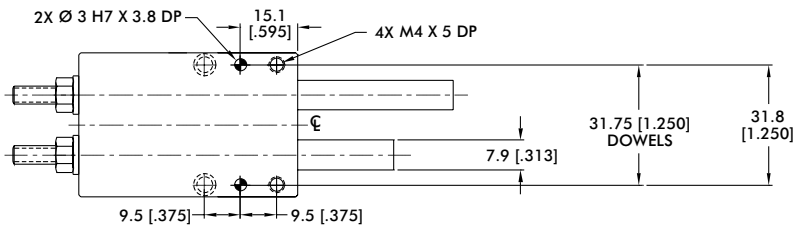
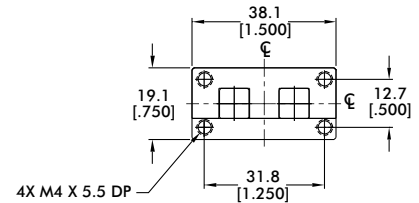
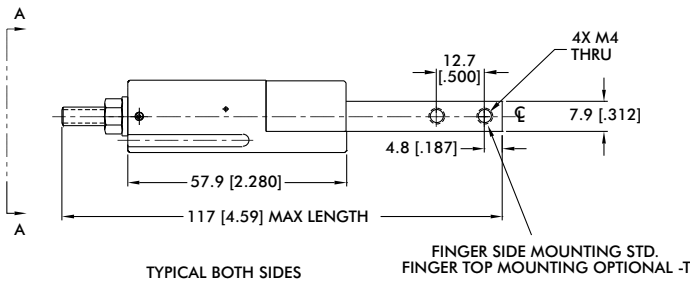
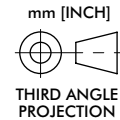
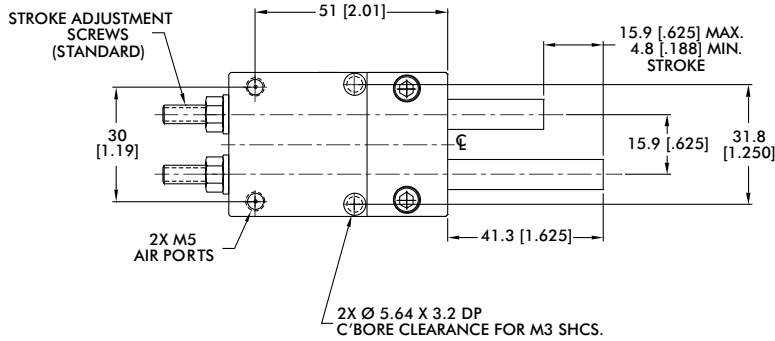

Seal Repair Kits	Order #
Buna-N Seal Repair Kit	SLKT-110
Viton® Seal Repair Kit	SLKT-110V

Loading Information

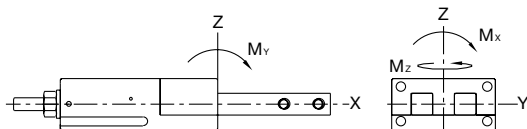

RFE-11M	Static
Maximum Moment M_x	6 Nm [50 in-lbs]
Maximum Moment M_y	6 Nm [50 in-lbs]
Maximum Moment M_z	6 Nm [50 in-lbs]

Cylinder Thrust Force

RFE-11M	Static
Thrust Force @ 7 bar [100psi]	111 N [25 lbs]
Thrust Force @ 5.5 bar [80 psi]	88 N [25 lbs]
Thrust Force @ 4 bar [60 psi]	66 N [15 lbs]
Thrust Force @ 2.7 bar [40 psi]	44 N [10 lbs]
Thrust Force @ 1.4 bar [20 psi]	22 N [5 lbs]

RFE-12M

Feed Escapements | Dimensions and Technical Specifications

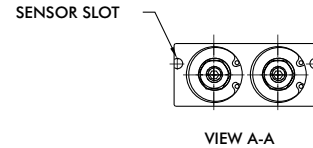
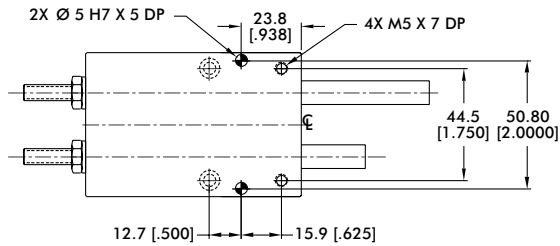
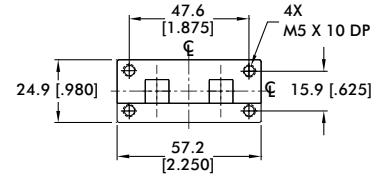
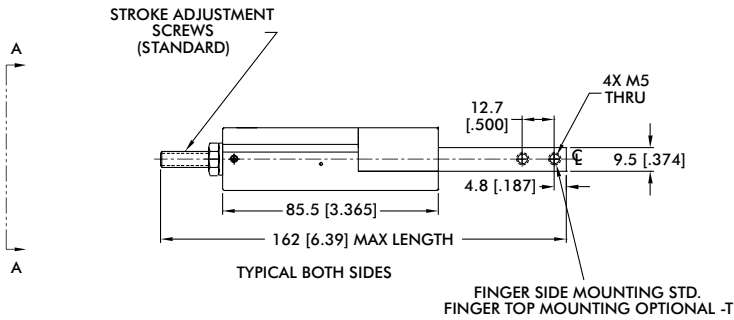
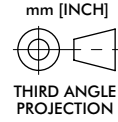
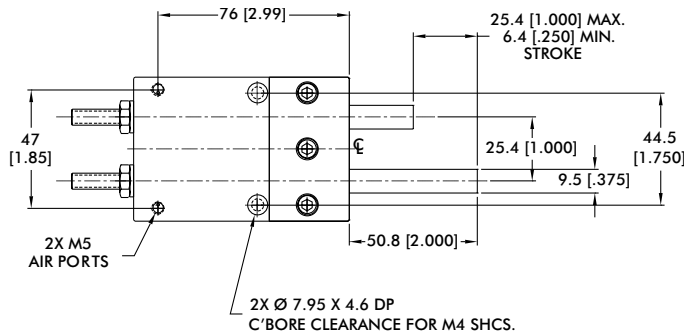

Seal Repair Kits	Order #
Buna-N Seal Repair Kit	SLKT-111
Viton® Seal Repair Kit	SLKT-111V

Loading Information

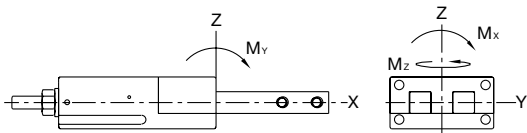

RFE-12M	Static
Maximum Moment M_x	17 Nm [150 in-lbs]
Maximum Moment M_y	17 Nm [150 in-lbs]
Maximum Moment M_z	17 Nm [150 in-lbs]

Cylinder Thrust Force

RFE-12M	Static
Thrust Force @ 7 bar [100psi]	216 N [50 lbs]
Thrust Force @ 5.5 bar [80 psi]	173 N [40 lbs]
Thrust Force @ 4 bar [60 psi]	130 N [30 lbs]
Thrust Force @ 2.7 bar [40 psi]	86 N [20 lbs]
Thrust Force @ 1.4 bar [20 psi]	43 N [10 lbs]

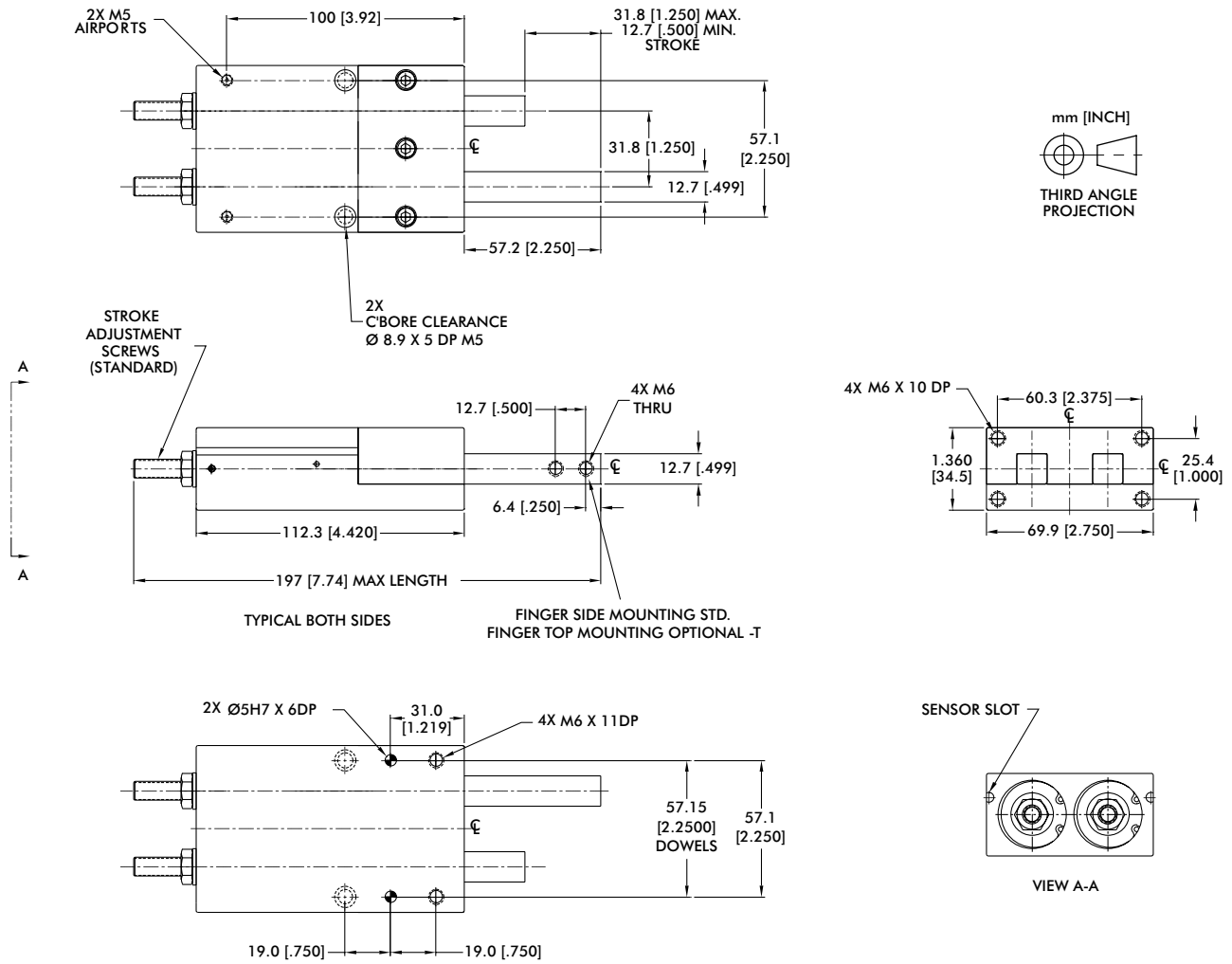

Seal Repair Kits	Order #
Buna-N Seal Repair Kit	SLKT-112
Viton® Seal Repair Kit	SLKT-112V

Loading Information

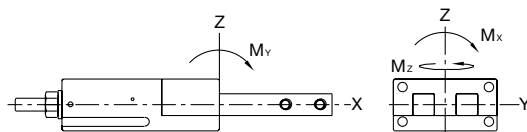

RFE-13M	Static
Maximum Moment M_x	28 Nm [250 in-lbs]
Maximum Moment M_y	28 Nm [250 in-lbs]
Maximum Moment M_z	28 Nm [250 in-lbs]

Cylinder Thrust Force

RFE-13M	Static
Thrust Force @ 7 bar [100psi]	394 N [88 lbs]
Thrust Force @ 5.5 bar [80 psi]	315 N [71 lbs]
Thrust Force @ 4 bar [60 psi]	236 N [53 lbs]
Thrust Force @ 2.7 bar [40 psi]	157 N [35 lbs]
Thrust Force @ 1.4 bar [20 psi]	78 N [17 lbs]

RN SERIES

Feed Escapements | Features and Benefits | How To Order | Technical Specifications

Features:

- Non-rotating square shaft maintains proper finger alignment
- Sealed design with adjustable retract stops
- Use independent or in tandem with other RN units
- Use in small load thruster applications
- Unit can be mounted using top, bottom or face surface

Applications:

- Conveying part separator
- Part quality ejector
- Feeder track overload guarding

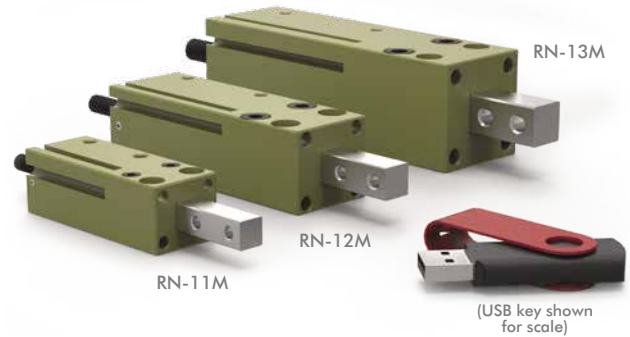

How To Order

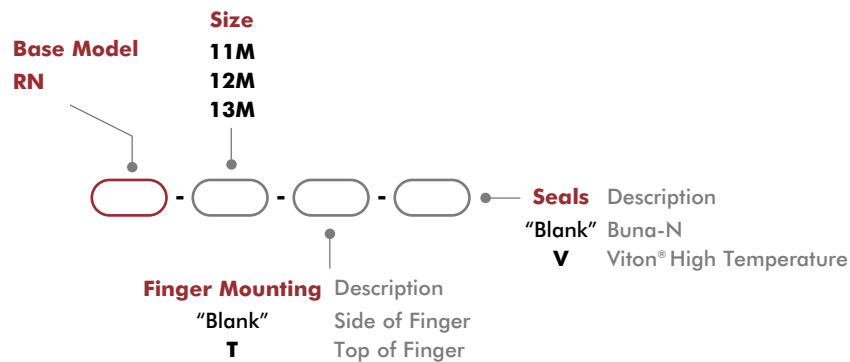

Accessories

Sensor Accessories	Model Numbers	Part Number	Qty/Unit
NPN Hall Effect Sensor with Quick Disconnect*	All Models	OHSN-006	1-2
PNP Hall Effect Sensor with Quick Disconnect*	All Models	OHSP-006	1-2
Quick Disconnect 2 Meter Cable Length*	All Models	CABL-010	1-2
Quick Disconnect 5 Meter Cable Length*	All Models	CABL-013	1-2

Pneumatic Accessories	Model Numbers	Part Number	Qty/Unit
M5 Adjustable Flow Control	All Models	VLVF-008	1-2

*Sensor and cable sold separately.

Specifications

Specifications	Units	11M	12M	13M
Thrust Force @ Maximum PSI	N [lbs]	111 [25]	222 [50]	400 [90]
Stroke	mm [in]	15.88 [0.625]	25.40 [1.000]	31.75 [1.250]
Stroke Adjustability	mm [in]	11 [0.44]	19 [0.75]	19 [0.75]
Weight	kg [lb]	0.09 [0.19]	0.19 [0.42]	0.41 [0.90]
Pressure Range	bar [psi]	3-7 [40-100]		
Cylinder Bore Ø	mm [in]	14.30 [0.563]	20 [0.787]	27 [1.063]
Rod Ø	mm [in]	6.35 [0.250]	7.95 [0.313]	9.52 [0.375]
Displacement	cm ³ [in ³]	1.3 [0.078]	4.0 [0.224]	9.1 [0.554]
Temperature Range (Buna-N seals)	°C [°F]	-35°~80° [-30°~180°]		
Temperature Range (Viton® seals)	°C [°F]	-30°~150° [-20°~300°]		
Actuation	sec	0.14	0.21	0.28
Valve to Actuate		4-way, 2-position		

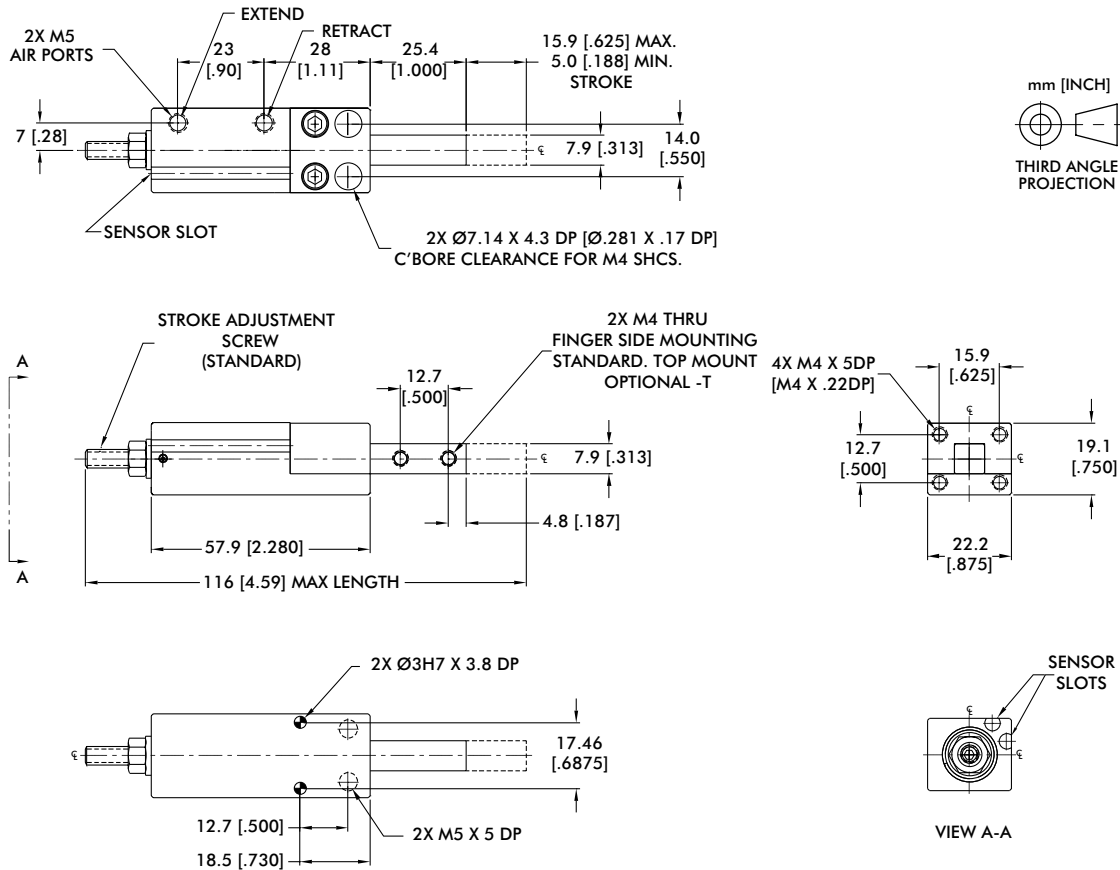

Seal Repair Kits	Order #
Buna-N Seal Repair Kit	SLKT-114
Viton® Seal Repair Kit	SLKT-114V

Loading Information

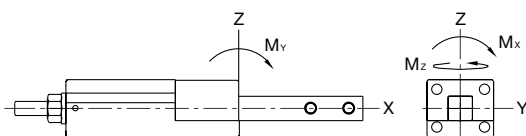

RN-11M	Static
Maximum Moment M_x	[50 in-lbs] 6 Nm
Maximum Moment M_y	[50 in-lbs] 6 Nm
Maximum Moment M_z	[50 in-lbs] 6 Nm

Cylinder Thrust Force

RN-11M	Extend	Retract
Thrust Force @ 7 bar [100psi]	111 N [25 lbs]	89 N [20 lbs]
Thrust Force @ 5.5 bar [80 psi]	88 N [20 lbs]	71 N [16 lbs]
Thrust Force @ 4 bar [60 psi]	66 N [15 lbs]	53 N [12 lbs]
Thrust Force @ 2.7 bar [40 psi]	44 N [10 lbs]	35 N [8 lbs]
Thrust Force @ 1.4 bar [20 psi]	22 N [5 lbs]	18 N [4 lbs]

RN-12M

Feed Escapements | Dimensions and Technical Specifications

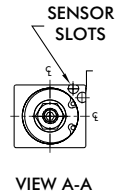
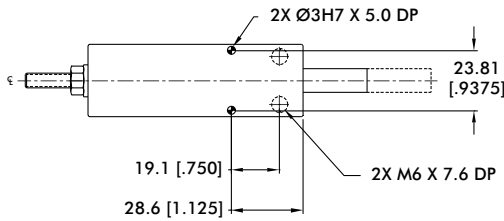
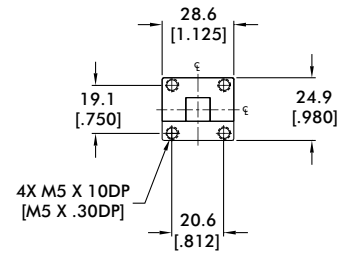
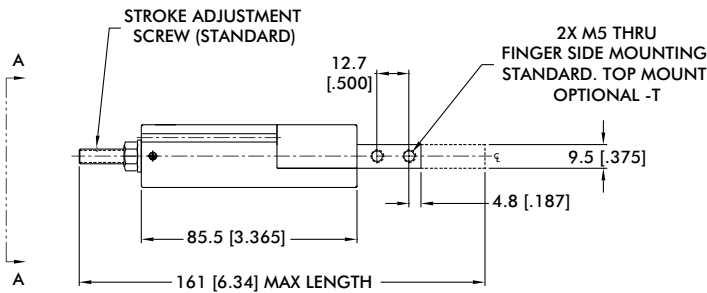
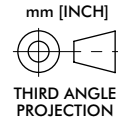
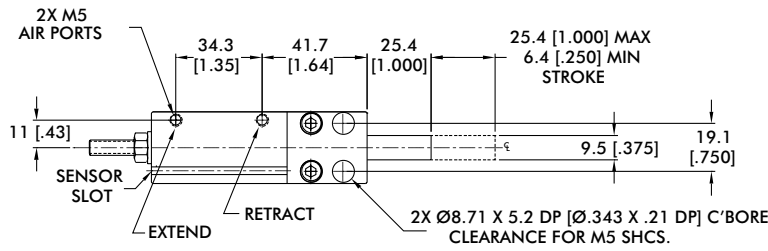

Seal Repair Kits	Order #
Buna-N Seal Repair Kit	SLKT-115
Viton® Seal Repair Kit	SLKT-115V

Loading Information

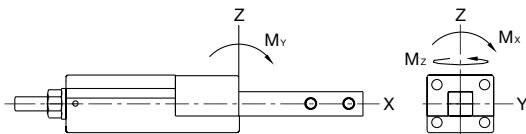

RN-12M	Static
Maximum Moment M_x	17 Nm [150 in-lbs]
Maximum Moment M_y	17 Nm [150 in-lbs]
Maximum Moment M_z	17 Nm [150 in-lbs]

Cylinder Thrust Force

RN-12M	Extend	Retract
Thrust Force @ 7 bar	217 N [49 lbs]	182 N [41 lbs]
Thrust Force @ 5.5 bar	173 N [39 lbs]	146 N [33 lbs]
Thrust Force @ 4 bar	130 N [29 lbs]	110 N [24 lbs]
Thrust Force @ 2.7 bar	87 N [19 lbs]	73 N [16 lbs]
Thrust Force @ 1.4 bar	43 N [10 lbs]	36 N [8 lbs]

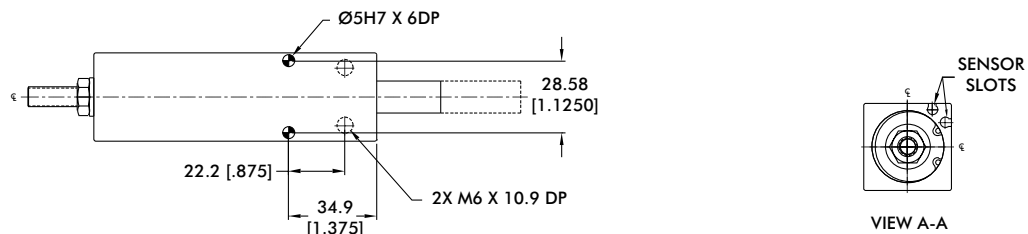
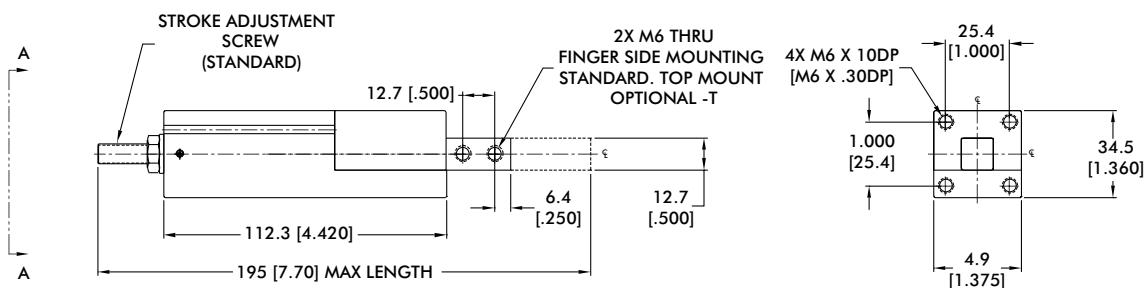
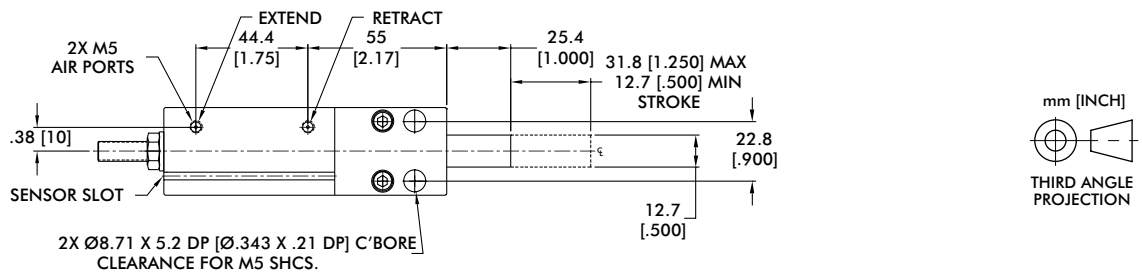

Seal Repair Kits	Order #
Buna-N Seal Repair Kit	SLKT-116
Viton® Seal Repair Kit	SLKT-116V

Loading Information

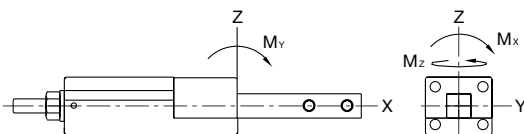

RN-13M	Static
Maximum Moment M_x	28 Nm [250 in-lbs]
Maximum Moment M_y	28 Nm [250 in-lbs]
Maximum Moment M_z	28 Nm [250 in-lbs]

Cylinder Thrust Force

RN-13M	Extend	Retract
Thrust Force @ 7 bar	394 N [88 lbs]	345 N [77 lbs]
Thrust Force @ 5.5 bar	315 N [71 lbs]	276 N [62 lbs]
Thrust Force @ 4 bar	236 N [53 lbs]	207 N [46 lbs]
Thrust Force @ 2.7 bar	157 N [35 lbs]	138 N [31 lbs]
Thrust Force @ 1.4 bar	78 N [18 lbs]	69 N [15 lbs]

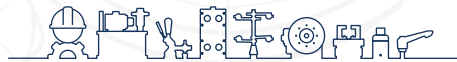

inf @ /CESEHSA.com.mx

