

3-Jaw Parallel Grippers

01/30/2025



info@cesehsa.com.mx

cesehsa.com.mx



3-Jaw Parallel Grippers

01/30/2025

This catalog is a custom document and the products included is based on your unique selection from portions of complete catalogs that already exist. Please refer to our full catalogs for more information on products not included in this customized document.

Table of Contents

3-Jaw Parallel Grippers

GR-3JP-1





3-Jaw Parallel Grippers

01/30/2025

Table of Contents (continued)

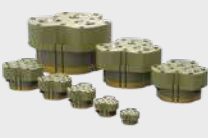
3-JAW PARALLEL GRIPPER SERIES

3-Jaw Parallel Grippers | Dimensions and Technical Specifications

Model	Stroke mm [in]	Grip Force N [lbs]	Operating Environment	Special Features	Page GR-3JP-#
3P 	10-50 [0.39-1.97]	422-11190 [95-2515]	IP54	Shielded Gripper with Spring Assist. Ideal for Round Parts. Tandem Cylinder Option. High Precision.	3
RTH 	4-70 [0.1575-2.756]	445-44353 [100-9971]	IP55 Using Purge Port. Cleanroom Class 100, ISO 5 Using Scavenge Port	Shielded for Harsh & Rugged Applications. Suitable for Machining and Coolant Applications. High Precision. Spring Assist.	15
PPC 	10-30 [0.394-1.181]	747-4332 [168-974]	IP54	Hole Through Center. High Precision. Harsh Environments. Round Parts Handling.	25
REP3 	10-30 [0.39-1.181]	480-3268 [108-753]	IP55. Cleanroom Class 100, ISO 5 Using Scavenge Port	Spring Assist. Rugged and Harsh Environments. Round Parts. High Precision.	31
RPC 	7.6-34.9 [0.3-1.38]	445-13345 [100-3000]	IP54	Harsh & Rugged Applications. High Precision. Round Parts Handling.	37

ENGINEERED RELIABILITY

Grippers, Rotates, and Linear Slide Solutions



Global Automation Solutions

DESTACO's Robohand products are engineered for reliability and long life to ensure maximum production uptime. These products are designed and machined for precise repeatability with minimal maintenance.



destaco.com

End Effectors | Grippers | Indexers | Manual Clamps | Power Clamps | Remote Handling

3P SERIES

3-Jaw Parallel Grippers | Features and Benefits | How To Order

Features:

- Robust and powerful precision multi-purpose gripper
- Pneumatic or hydraulic powered operation
- Optional tandem cylinder doubles grip force
- Protective boot and shielded design for harsh environments
- Spring assist option maintains grip in case of air pressure loss
- Uses inductive sensors for jaw position detection

Applications:

- Hydraulic powered gripping applications
- Confined spaces in harsh environment applications
- Welding applications with protective boot option



How To Order

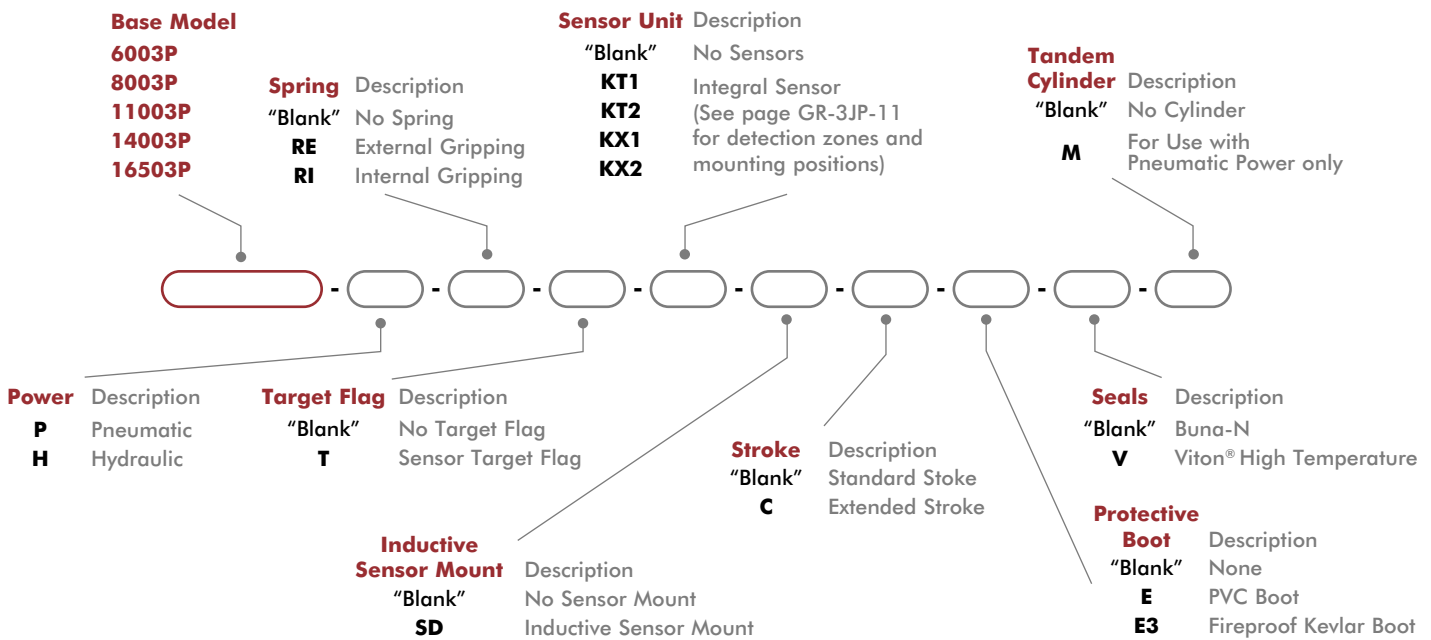

Accessories

Sensor Accessories	Model Numbers	Part Number	Qty/Unit
M8 Inductive Sensor PNP with M8 Connector	6003P, 8003P, 11003P	OISP-011	1-4
M8 Inductive Sensor NPN with M8 Connector	6003P, 8003P, 11003P	OISN-011	1-4
M8 Inductive Sensor PNP with M12 Connector	14003P, 16503P	OISP-017	1-4
M8 Inductive Sensor NPN with M12 Connector	14003P, 16503P	OISN-017	1-4
M8 Quick Disconnect 2 Meter Cable Length*	6003P, 8003P, 11003P	CABL-010	1-4
M12 Quick Disconnect 2 Meter Cable Length*	14003P, 16503P	CABL-014	1-4
Inductive Sensor Mounting Kit (1 holder, 1 flag, 2 spacers)	6003P, 8003P	SD60-80P	1-2
Inductive Sensor Mounting Kit (1 holder, 1 flag, 2 spacers)	11003P	SD110P	1-2
Inductive Sensor Mounting Kit (1 holder, 1 flag, 2 spacers)	14003P	OSMK-114	1-2
Inductive Sensor Mounting Kit (1 holder, 1 flag, 2 spacers)	16503P	OSMK-115	1-2

*Sensor and cable sold separately.

Specifications	Units	6003P-P	6003P-P-C	8003P-P	8003P-P-C	11003P-P	11003P-P-C
Grip Force (F6+R)1, 6 bar [87 psi], Springs Mid-Way, L=0	N [lbs]	678 [152]	422 [95]	1888 [424]	1219 [274]	1979 [445]	2030 [456]
Grip Force (F0+R)2, 0 bars, Springs Mid-Way, L=0	N [lbs]	172 [39]	107 [24]	617 [139]	398 [89]	628 [141]	644 [145]
Total Stroke	mm [in]	10 [0.39]	16 [0.63]	13 [0.51]	20 [0.79]	20 [0.79]	30 [1.18]
Weight	kg [lbs]	0.60 [1.32]		0.97 [2.14]		2.35 [5.18]	
Pressure Range w/o Spring	bar [psi]	2-7 [30-100]					
Pressure Range with Spring	bar [psi]	4-7 [60-100]					
Ingress Protection Class (IP)		IP54					
Displacement	cm ³ [in ³]	12 [0.73]		35 [2.14]		87 [5.31]	
Temp. Range (Buna-N seals)	°C [°F]	-35°~80° [-30°~180°]					
Temp. Range (Viton® seals)	°C [°F]	-30°~150° [-20°~300°]					
Actuation (open/close)	sec.	0.07		0.08		0.10	
Repeatability	mm [in]	±0.02 [±0.001]					

Specifications	Units	14003P-P	14003P-P-C	16503P-P	16503P-P-C
Grip Force (F6+R)1, 6 bar [87 psi], Springs Mid-Way, L=0	N [lbs]	6077 [1366]	4031 [906]	11190 [2515]	6878 [1546]
Grip Force (F0+R)2, 0 bars, Springs Mid-Way, L=0	N [lbs]	2248 [508]	1490 [335]	3730 [838]	2292 [515]
Total Stroke	mm [in]	26 [1.02]	40 [1.57]	30 [1.18]	50 [1.97]
Weight	kg [lbs]	4.7 [10.36]		9.04 [19.92]	
Pressure Range w/o Spring	bar [psi]	2-7 [30-100]			
Pressure Range with Spring	bar [psi]	4-7 [60-100]			
Ingress Protection Class (IP)		IP54			
Displacement	cm ³ [in ³]	220 [13.43]		494 [30.15]	
Temp. Range (Buna-N seals)	°C [°F]	-35°~80° [-30°~180°]			
Temp. Range (Viton® seals)	°C [°F]	-30°~150° [-20°~300°]			
Actuation (open/close)	sec.	0.16		0.29	
Repeatability	mm [in]	±0.02 [±0.001]			

6003P, 6003P-C

3-Jaw Parallel Grippers | Dimensions and Technical Specifications

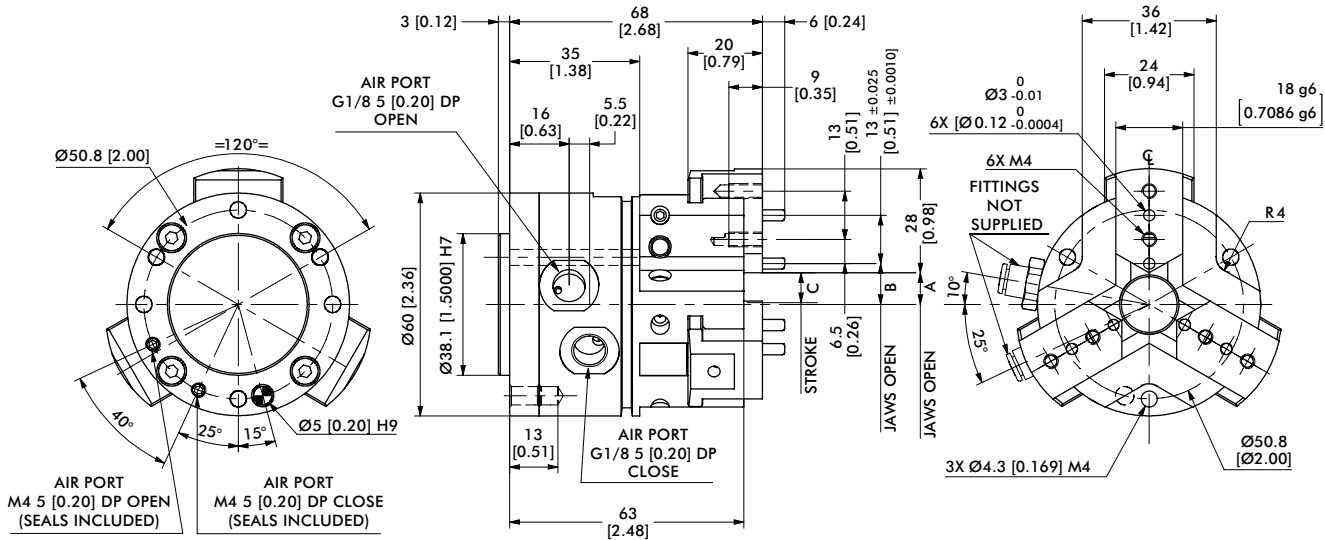

OUR GRIPPERS ARE SUPPLIED WITH OPEN SIDE AIR PORTS AND TOP AIR PORTS PLUGGED. WHEN OPERATING TOP AIR PORTS, PRODUCES MANIFOLD SEALING AS SHOWN.

GRIPPERS TOP AIR PORT

O-RING Ø1.5 X Ø4

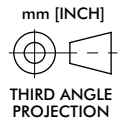

Model	A	B	C
6003P	5.5 [0.22]	8 [0.31]	5 [0.20]
6003P-C	8.5 [0.33]	11 [0.43]	8 [0.31]

Dimensions in mm [in]

Protective Boots	6003P
PVC Protective Boot, Brown or Black	ER63P
Fireproof KEVLAR Protective Boot, Red	E3R63P

Seal Repair Kits	6003P
Buna-N Seal Repair Kit	SLKT-156
Viton® Seal Repair Kit	SLKT-156V
Hydraulic Seal Repair Kit	SLKT-330

Loading Information

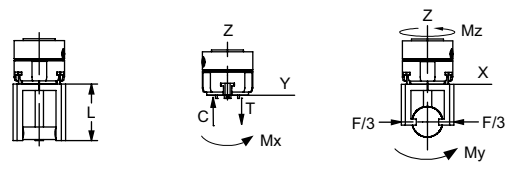
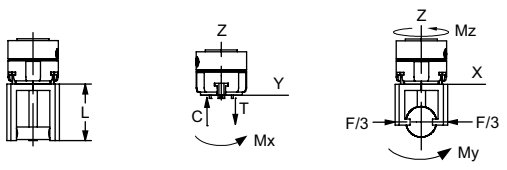
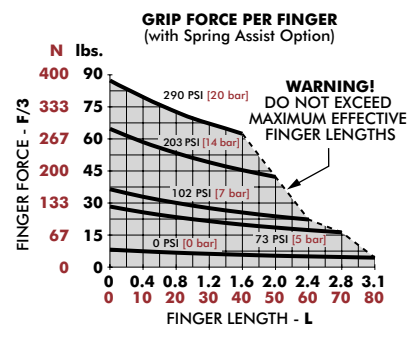
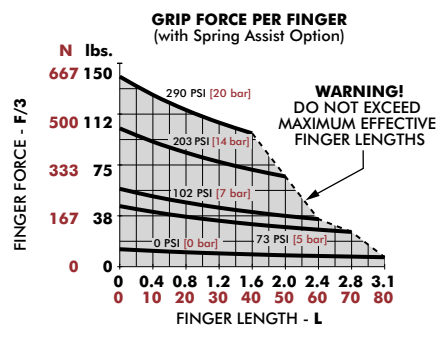

6003P	Static	Dynamic
Maximum Tensile T	819 N [184 lbs]	175 N [39 lbs]
Maximum Compressive C	1556 N [350 lbs]	175 N [39 lbs]
Maximum Moment M_x	42 Nm [372 in-lbs]	5 Nm [44 in-lbs]
Maximum Moment M_y	49 Nm [434 in-lbs]	6 Nm [53 in-lbs]
Maximum Moment M_z	54 Nm [478 in-lbs]	6 Nm [53 in-lbs]

6003P-C	Static	Dynamic
Maximum Tensile T	745 N [167 lbs]	108 N [24 lbs]
Maximum Compressive C	1415 N [318 lbs]	108 N [24 lbs]
Maximum Moment M_x	34 Nm [301 in-lbs]	3 Nm [27 in-lbs]
Maximum Moment M_y	39 Nm [345 in-lbs]	4 Nm [35 in-lbs]
Maximum Moment M_z	49 Nm [434 in-lbs]	4 Nm [35 in-lbs]

*Capacities are per set of jaws and are not simultaneous

*Capacities are per set of jaws and are not simultaneous

8003P, 8003P-C

3-Jaw Parallel Grippers | Dimensions and Technical Specifications

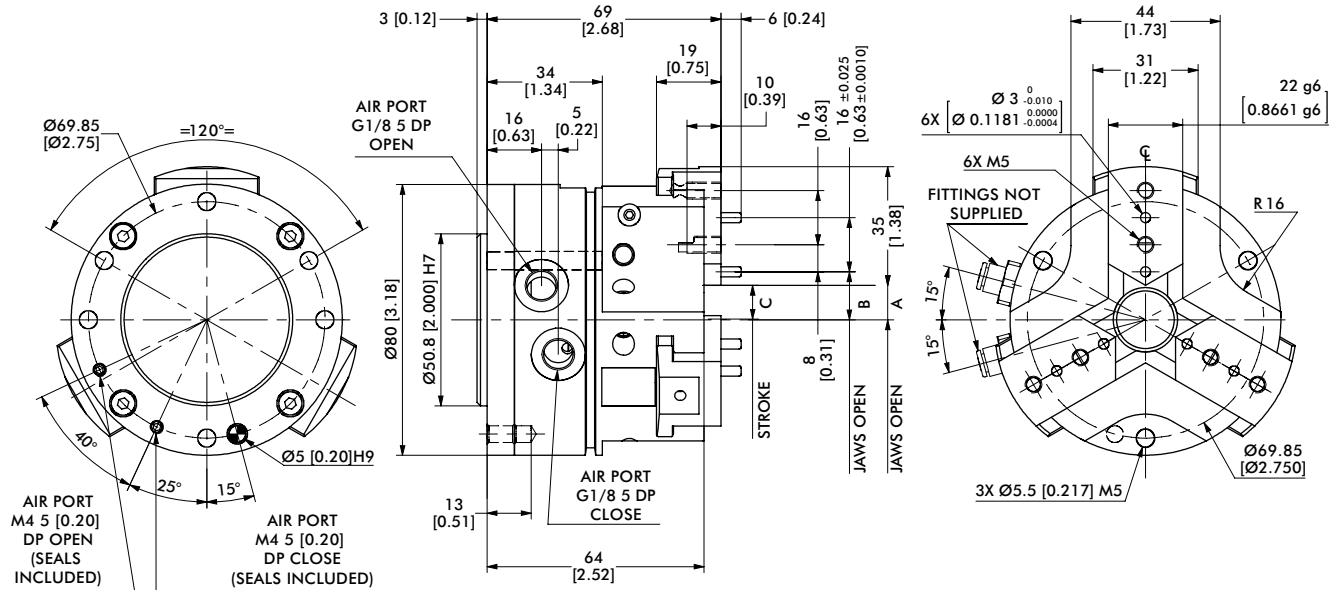

OUR GRIPPERS ARE SUPPLIED WITH OPEN SIDE AIR PORTS AND TOP AIR PORTS PLUGGED. WHEN OPERATING TOP AIR PORTS, PRODUCES MANIFOLD SEALING AS SHOWN.

GRIPPERS TOP AIR PORT
O-RING Ø1.5 X Ø4

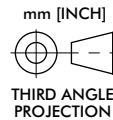

Model	A	B	C
8003P	6.8 [0.27]	10.8 [0.43]	6.5 [0.26]
8003P-C	10.2 [0.40]	14.2 [0.56]	10 [0.39]

Dimensions in mm [in]

Protective Boots	8003P
PVC Protective Boot, Brown or Black	ER83P
Fireproof KEVLAR Protective Boot, Red	E3R83P

Seal Repair Kits	8003P
Buna-N Seal Repair Kit	S80
Viton® Seal Repair Kit	S80V
Hydraulic Seal Repair Kit	S80H

Loading Information

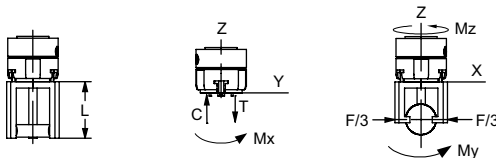
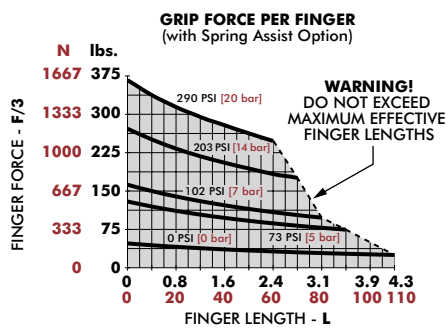

8003P	Static	Dynamic
Maximum Tensile T	1229 N [276 lbs]	436 N [98 lbs]
Maximum Compressive C	2075 N [466 lbs]	436 N [98 lbs]
Maximum Moment M_x	60 Nm [531 in-lbs]	16 Nm [142 in-lbs]
Maximum Moment M_y	68 Nm [602 in-lbs]	19 Nm [168 in-lbs]
Maximum Moment M_z	37 Nm [327 in-lbs]	19 Nm [168 in-lbs]

*Capacities are per set of jaws and are not simultaneous

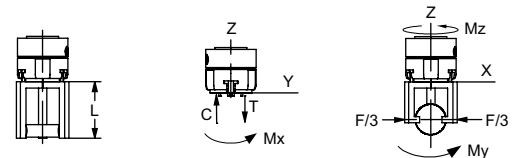
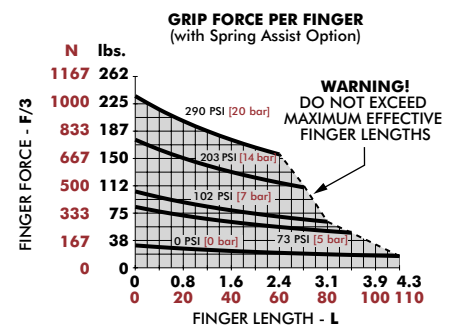

8003P-C	Static	Dynamic
Maximum Tensile T	1097 N [247 lbs]	281 N [63 lbs]
Maximum Compressive C	1853 N [416 lbs]	281 N [63 lbs]
Maximum Moment M_x	39 Nm [345 in-lbs]	12 Nm [106 in-lbs]
Maximum Moment M_y	44 Nm [389 in-lbs]	13 Nm [115 in-lbs]
Maximum Moment M_z	34 Nm [301 in-lbs]	13 Nm [115 in-lbs]

*Capacities are per set of jaws and are not simultaneous

11003P, 11003P-C

3-Jaw Parallel Grippers | Dimensions and Technical Specifications

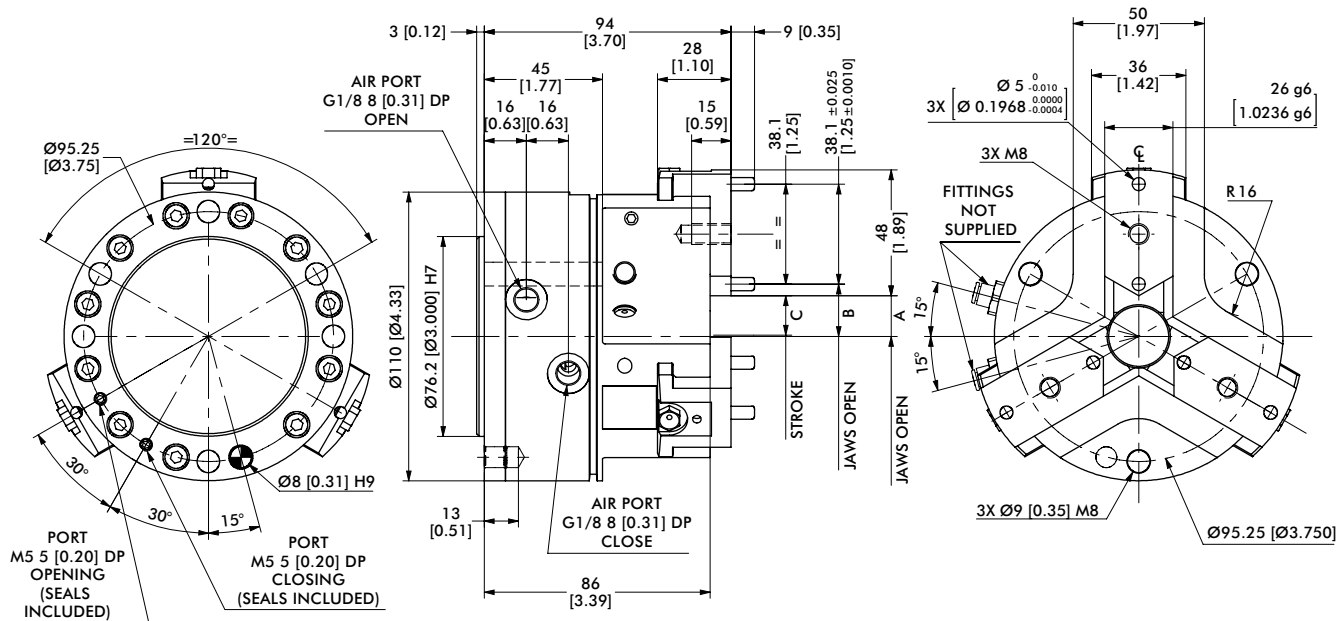

OUR GRIPPERS ARE SUPPLIED WITH OPEN SIDE AIR PORTS AND TOP AIR PORTS PLUGGED. WHEN OPERATING TOP AIR PORTS, PRODUCES MANIFOLD SEALING AS SHOWN.

GRIPPERS TOP AIR PORT

O-RING Ø1.5 X Ø5

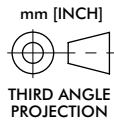

Model	A	B	C
11003P	10.5 [0.41]	15 [0.59]	10 [0.39]
11003P-C	15.5 [0.61]	20 [0.79]	15 [0.59]

Dimensions in mm [in]

Protective Boots	11003P
PVC Protective Boot, Brown or Black	ER113P
Fireproof KEVLAR Protective Boot, Red	E3R113P

Seal Repair Kits	11003P
Buna-N Seal Repair Kit	S110
Viton® Seal Repair Kit	S110V
Hydraulic Seal Repair Kit	S110H

Loading Information

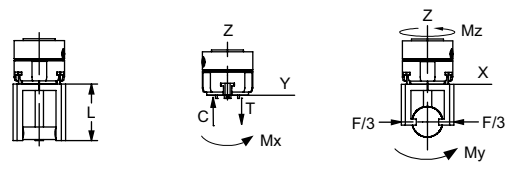
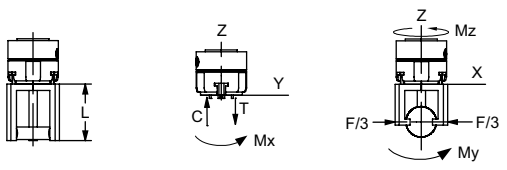
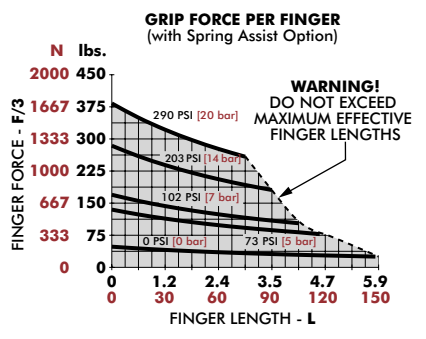
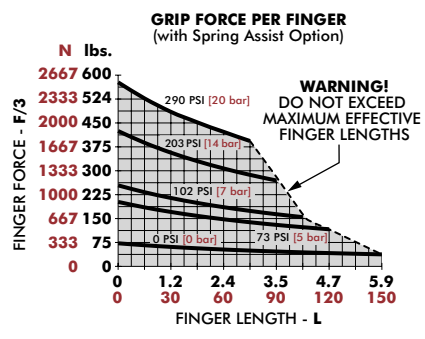

11003P	Static	Dynamic
Maximum Tensile T	1560 N [351 lbs]	695 N [156 lbs]
Maximum Compressive C	2652 N [596 lbs]	695 N [156 lbs]
Maximum Moment M_x	60 Nm [531 in-lbs]	31 Nm [274 in-lbs]
Maximum Moment M_y	80 Nm [708 in-lbs]	41 Nm [363 in-lbs]
Maximum Moment M_z	90 Nm [797 in-lbs]	41 Nm [363 in-lbs]

11003P-C	Static	Dynamic
Maximum Tensile T	1418 N [319 lbs]	463 N [104 lbs]
Maximum Compressive C	2411 N [542 lbs]	463 N [104 lbs]
Maximum Moment M_x	50 Nm [443 in-lbs]	22 Nm [195 in-lbs]
Maximum Moment M_y	66 Nm [584 in-lbs]	30 Nm [266 in-lbs]
Maximum Moment M_z	84 Nm [743 in-lbs]	30 Nm [266 in-lbs]

*Capacities are per set of jaws and are not simultaneous

*Capacities are per set of jaws and are not simultaneous

14003P, 14003P-C

3-Jaw Parallel Grippers | Dimensions and Technical Specifications

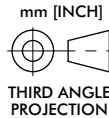
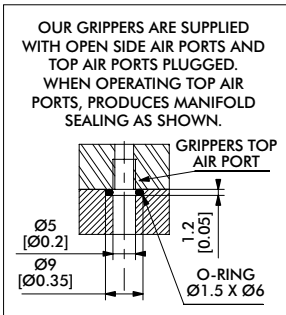
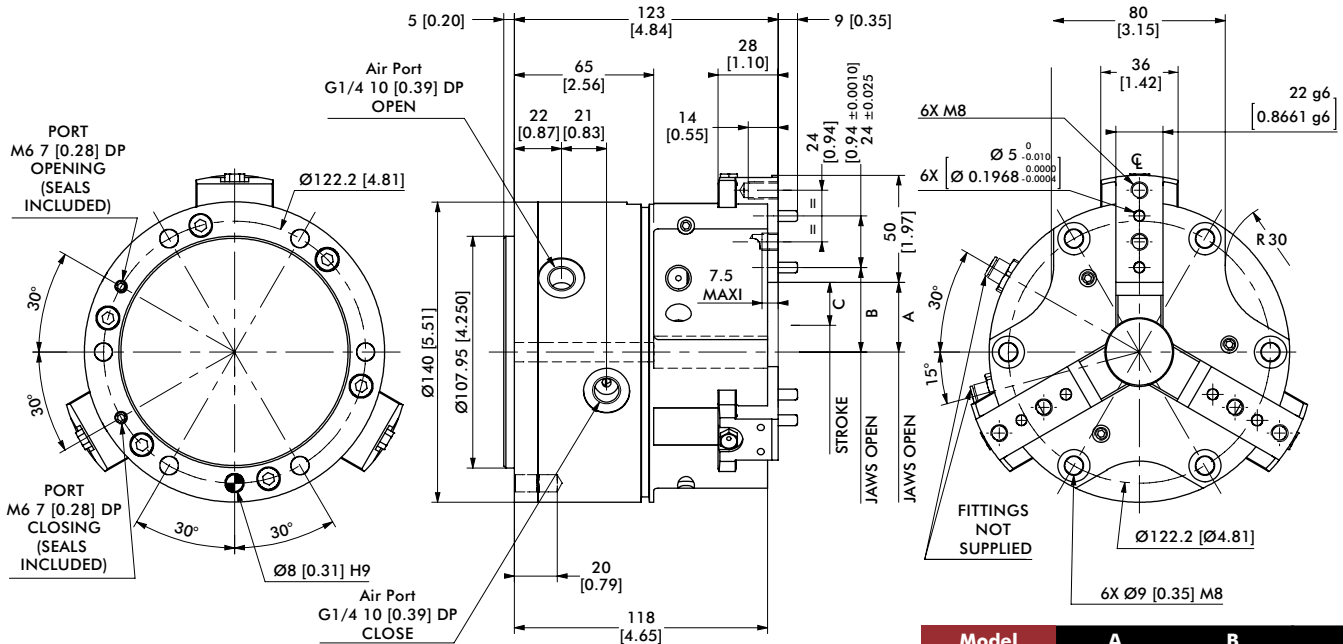

Model	A	B	C
14003P	25.5 [1.00]	32.5 [1.28]	13 [0.51]
14003P-C	32.5 [1.28]	39.5 [1.56]	20 [0.79]

Dimensions in mm [in]

Protective Boots	14003P
PVC Protective Boot, Brown or Black	KP-317
Fireproof KEVLAR Protective Boot, Red	KP-319

Seal Repair Kits	14003P
Buna-N Seal Repair Kit	SLKT-333
Viton® Seal Repair Kit	SLKT-333V
Hydraulic Seal Repair Kit	SLKT-334

Loading Information

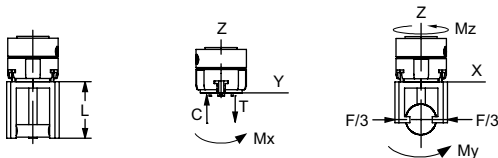
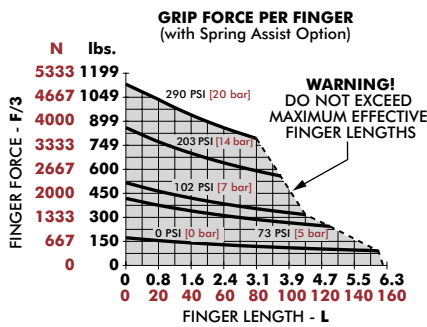

14003P	Static	Dynamic
Maximum Tensile T	2390 N [537 lbs]	850 N [191 lbs]
Maximum Compressive C	2700 N [607 lbs]	850 N [191 lbs]
Maximum Moment M_x	85 Nm [752 in-lbs]	25 Nm [221 in-lbs]
Maximum Moment M_y	130 Nm [1151 in-lbs]	40 Nm [354 in-lbs]
Maximum Moment M_z	100 Nm [885 in-lbs]	40 Nm [354 in-lbs]

*Capacities are per set of jaws and are not simultaneous

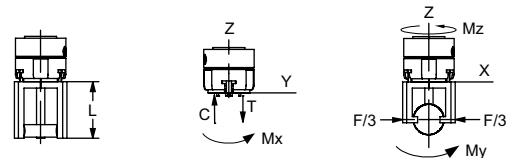
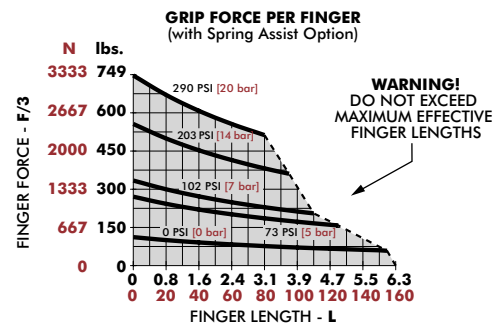

14003P-C	Static	Dynamic
Maximum Tensile T	2180 N [490 lbs]	590 N [133 lbs]
Maximum Compressive C	2500 N [562 lbs]	590 N [133 lbs]
Maximum Moment M_x	75 Nm [664 in-lbs]	20 Nm [177 in-lbs]
Maximum Moment M_y	110 Nm [974 in-lbs]	32 Nm [283 in-lbs]
Maximum Moment M_z	90 Nm [797 in-lbs]	32 Nm [283 in-lbs]

*Capacities are per set of jaws and are not simultaneous

16503P, 16503P-C

3-Jaw Parallel Grippers | Dimensions and Technical Specifications

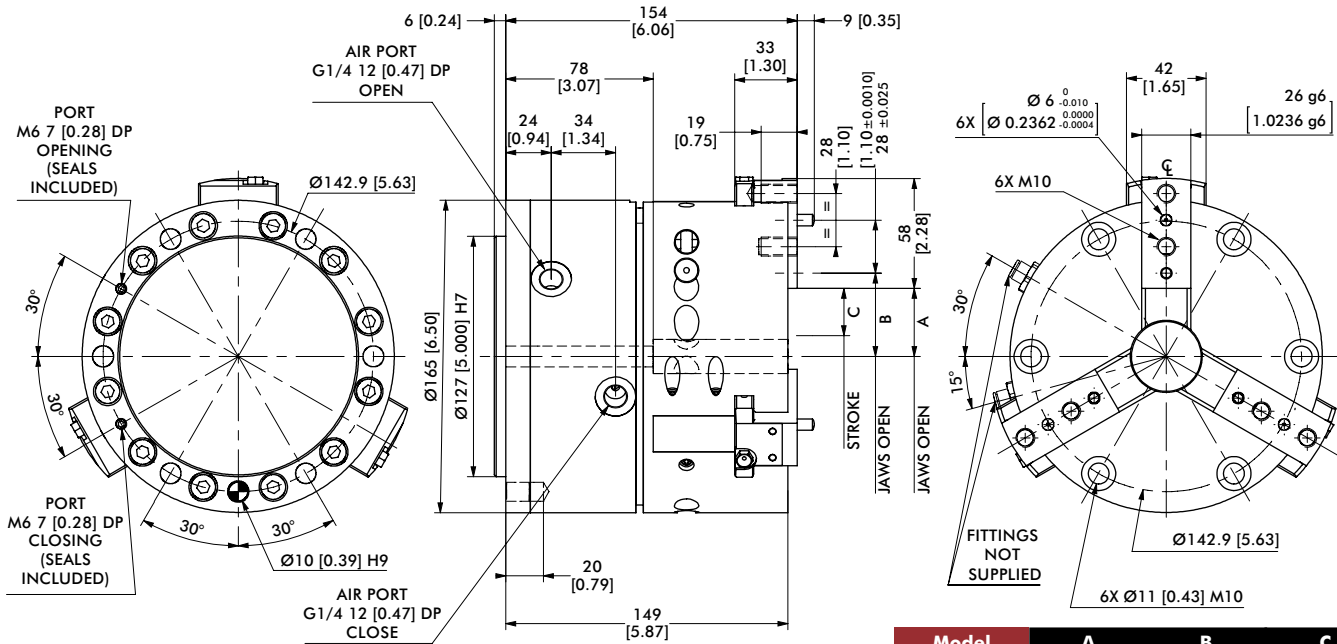

OUR GRIPPERS ARE SUPPLIED WITH OPEN SIDE AIR PORTS AND TOP AIR PORTS PLUGGED. WHEN OPERATING TOP AIR PORTS, PRODUCES MANIFOLD SEALING AS SHOWN.

GRIPPERS TOP AIR PORT

O-RING Ø1.5 X Ø6

mm [INCH]
THIRD ANGLE PROJECTION

Model	A	B	C
16503P	31 [1.22]	39 [1.54]	15 [0.59]
16503P-C	36 [1.42]	44 [1.73]	25 [0.98]

Dimensions in mm [in]

Protective Boots	16503P
PVC Protective Boot, Brown or Black	KP-320
Fireproof KEVLAR Protective Boot, Red	KP-322

Seal Repair Kits	16503P
Buna-N Seal Repair Kit	SLKT-335
Viton® Seal Repair Kit	SLKT-335V
Hydraulic Seal Repair Kit	SLKT-336

Loading Information

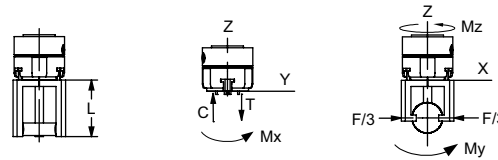
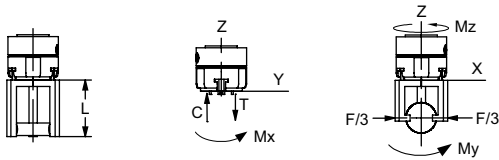
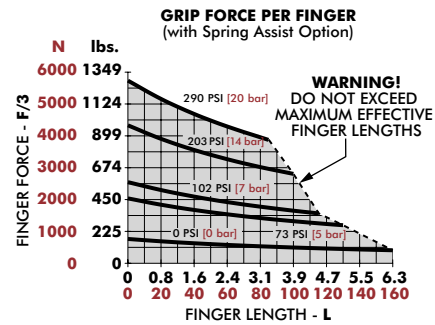
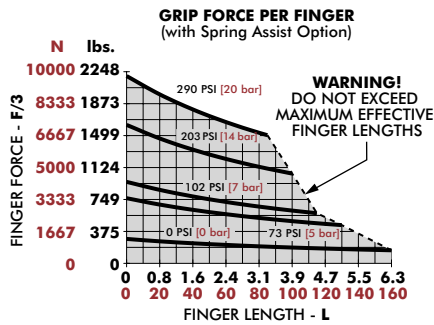

16503P	Static	Dynamic
Maximum Tensile T	2580 N [580 lbs]	980 N [220 lbs]
Maximum Compressive C	3200 N [719 lbs]	980 N [220 lbs]
Maximum Moment M_x	100 Nm [885 in-lbs]	32 Nm [283 in-lbs]
Maximum Moment M_y	150 Nm [1328 in-lbs]	50 Nm [443 in-lbs]
Maximum Moment M_z	140 Nm [1239 in-lbs]	50 Nm [443 in-lbs]

16503P-C	Static	Dynamic
Maximum Tensile T	2250 N [506 lbs]	810 N [182 lbs]
Maximum Compressive C	2800 N [629 lbs]	810 N [182 lbs]
Maximum Moment M_x	90 Nm [797 in-lbs]	28 Nm [248 in-lbs]
Maximum Moment M_y	140 Nm [1239 in-lbs]	40 Nm [354 in-lbs]
Maximum Moment M_z	130 Nm [1151 in-lbs]	40 Nm [354 in-lbs]

*Capacities are per set of jaws and are not simultaneous

*Capacities are per set of jaws and are not simultaneous

3P OPTIONS & ACCESSORIES

3-Jaw Parallel Grippers | Dimensions and Technical Specifications

SUPPLY: (P) Pneumatic (H) (H80) Hydraulic

As standard, the clamp is supplied with air to a pressure of 7 bar. On request (contact us) the gripper can be supplied with hydraulic fluid. The clamp is fitted with seals Viton Quad-Ring.

- Choice (H) allows a hydraulic power to a pressure of 20 bar max. In this case the overall dimensions do not change. For better security the gripper must be fixed on their support before being fired.

CAUTION: Hydraulic cycle times are longer.

The hydraulic power is incompatible with the option tandem (M).

Option (RE) or (RI): Spring Assist

The internal springs of the gripper ensures grip force is maintained by retaining the component during pressure loss, to increase the gripforce, or allows the usage of the gripper in single acting operation.

Option (RE) for external gripping. Option (RI) for internal gripping.

The (RE) is incompatible with the option (RI).

Option (T): Sensor Rod

Option (T) is a steel rod which comes out on the rear side of the gripper. The rod is fixed with the piston and has the same stroke movement. The open end of the rod allows for mounting a cam which allows to control the position of the jaws by using inductive sensors, micro switches, etc

WARNING: when screwing on cam rod, make sure the sensor rod does not rotate to prevent twisting of the springs of options (RE) or (RI).

Option (T) is incompatible with option (K).

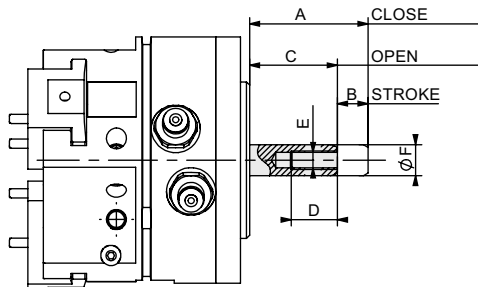

Model	A	B	C	D	E	F
6003P & 6003P-C	35	5	30	15	M6	10
8003P & 8003P-C	35	6.5	28.5	15	M6	10
11003P & 11003P-C	35	10	25	15	M6	15
14003P & 14003P-C	55	13	42	20	M8	15
16503P & 16503P-C	53	23	30	20	M8	15

Option (M): Tandem Cylinder

The (M) is a cylinder light-alloy that fits behind the bottom plate. This actuator's integral action allows to double the gripforce by using the same pressure. The combination of tandem option tandem (M) and Option (RE) or (RI) can double the clamping forces of the spring assist option. For cycle times of the tandem option, apply a factor of 3 to the actuation time.

The (M) is incompatible with the option (H).

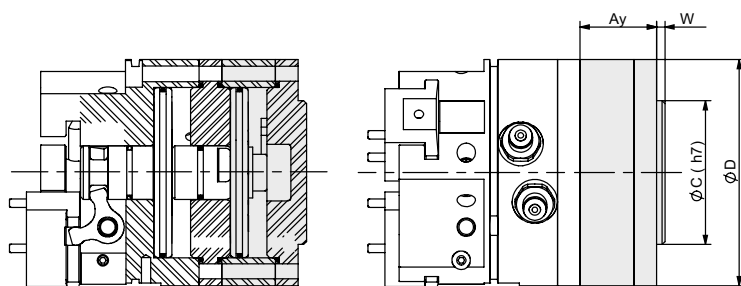

Model	Ay	ØC	ØD	W	Weight (kg)
6003P & 6003P-C	28.5	38.1	60	3	0.200
8003P & 8003P-C	27	50.8	80	3	0.300
11003P & 11003P-C	34	76.2	110	3	0.750
14003P & 14003P-C	49	107.95	140	5	2.100
16503P & 16503P-C	65	127	165	6	3.600

3P OPTIONS & ACCESSORIES

3-Jaw Parallel Grippers | Dimensions and Technical Specifications

Option (KT1), (KX1), (KT2), (KX2): Sensor Unit

The (K) is a lightweight alloy housing that fits on the back of the gripper. An integrated shaft follows the movement of the piston to provide information to the sensor attached to the side of the unit. It can control two positions of the grippers jaws. 2 types of inductive sensors (KT, KX) and 2 detection zones (1, 2) are possible to allow for the combination of 2 to 4 possible positions (KT1, KX1, KT2, KX2). For KT, KX sensor specifications.

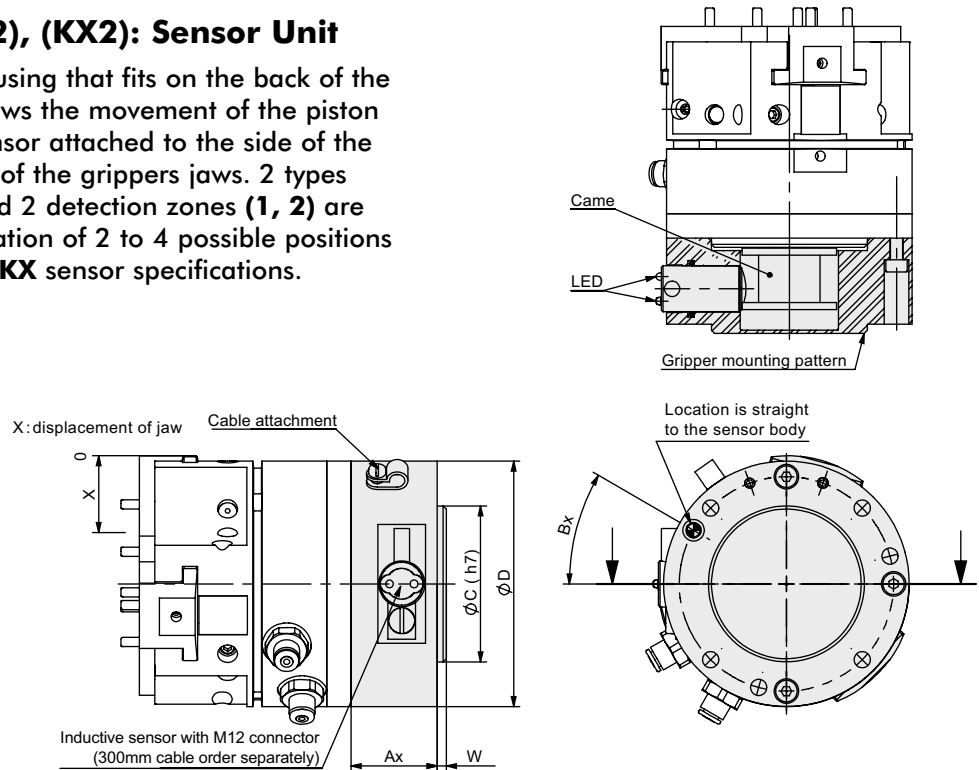

Model	Ax	Bx	øC	øD	W	Weight (k(g))	No. of Sensing Positions (please specify when ordering)	Information area from the open grip position (green LED) X (mm)	Area information relative to the closed grip position X (mm)
6003P	23	30°	38.1	60	3	0.180	1	0 or 1 ^{+0,5} ₋₀	4 ^{+0,5} ₋₀ or 5
							2	0 or 2 ^{+0,5} ₋₀	3 ^{+0,5} ₋₀ or 5
6003P-C	23	30°	38.1	60	3	0.180	1	0 or 1.6 ^{+0,8} ₋₀	7 ^{+0,8} ₋₀ or 8
							2	0 or 3.2 ^{+0,8} ₋₀	4.8 ^{+0,8} ₋₀ or 8
8003P	28	30°	50.8	80	3	0.400	1	0 or 1 ^{+0,5} ₋₀	5.5 ^{+0,5} ₋₀ or 6,5
							2	0 or 2 ^{+0,5} ₋₀	4.5 ^{+0,5} ₋₀ or 6,5
8003P-C	28	30°	50.8	80	3	0.400	1	0 or 1.5 ^{+0,8} ₋₀	8.5 ^{+0,8} ₋₀ or 10
							2	0 or 3.1 ^{+0,8} ₋₀	6.9 ^{+0,8} ₋₀ or 10
11003P	36	30°	76.2	110	3	0.900	1	0 or 1 ^{+0,5} ₋₀	9 ^{+0,5} ₋₀ or 10
							2	0 or 3 ^{+0,5} ₋₀	7 ^{+0,5} ₋₀ or 10
11003P-C	36	30°	76.2	110	3	0.900	1	0 or 1.5 ^{+0,8} ₋₀	13.5 ^{+0,8} ₋₀ or 15
							2	0 or 4.5 ^{+0,8} ₋₀	10.5 ^{+0,8} ₋₀ or 15
14003P	45.5	165°	107.95	140	5	1.670	1	0 or 2 ^{+0,5} ₋₀	11 ^{+0,5} ₋₀ or 13
							2	0 or 4 ^{+0,5} ₋₀	9 ^{+0,5} ₋₀ or 13
14003P-C	45.5	165°	107.95	140	5	1.670	1	0 or 3 ^{+0,8} ₋₀	17 ^{+0,8} ₋₀ or 20
							2	0 or 6.2 ^{+0,8} ₋₀	13.8 ^{+0,8} ₋₀ or 20
16003P	65.5	165°	127	165	6	2.670	1	0 or 2 ^{+0,5} ₋₀	13 ^{+0,5} ₋₀ or 15
							2	0 or 4 ^{+0,5} ₋₀	11 ^{+0,5} ₋₀ or 15
16003P-C	65.5	165°	127	165	6	2.670	1	0 or 3.3 ^{+0,8} ₋₀	21.7 ^{+0,8} ₋₀ or 25
							2	0 or 7 ^{+0,8} ₋₀	18 ^{+0,8} ₋₀ or 25

3P OPTIONS & ACCESSORIES

3-Jaw Parallel Grippers | Dimensions and Technical Specifications

Option (V): Viton® Seals

Gripper with Viton® seals allows for use in high temperature environments [-30 ° C or 150 ° C].

Accessory (E): Protective Boot

The accessory (E) is a protective boot that fits over the gripper. It protects the mechanism and thus improves the life of the gripper in hostile environments. The accessory (E) causes a different location of the fingers on the jaws as compared to the standard installation. Before attaching the boot, perform the following steps:

1. Mount gripper to machine.
2. Slip boot over gripper and secure in place.
3. Attached fingers to jaws using finger adapter.

Depending on the environment 2 types of envelopes are available:

(E) Envelope of black or brown PVC for environmental grinding with emery presence.

(E3) red envelope containing KEVLAR fireproof silicone environment for hot chips and weld spatter.

The accessory (E) is incompatible with the accessory (SD)

Model Code	Order #	Model	A	B	C	D	E	F	G	H	J	K	S	T	TX	V	Y
E	ER62P	6003P & 6003P-C	88	98	35	13.5	8	29	29	17.5	13	-	3	M4	9	13	6
E3	E3R62P																
E	ER82P	8003P & 8003P-C	89	110	34	13.5	10	33	30	22.3	16	-	3	M5	10	16	6
E3	E3R82P																
E	ER112P	11003P & 11003P-C	See Drawing														
E3	E3R112P																
E	KP-311	14003P & 14003P-C	143	185	50	18	12	55	34	19.5	24	18	5	M8	14	-	8
E3	KP-313																
E	KP-314	16003P & 16003P-C	172	220	70	16	14	67	37	24 19	28	23	6	M10	19	-	8
E3	KP-316																

6003P & 8003P

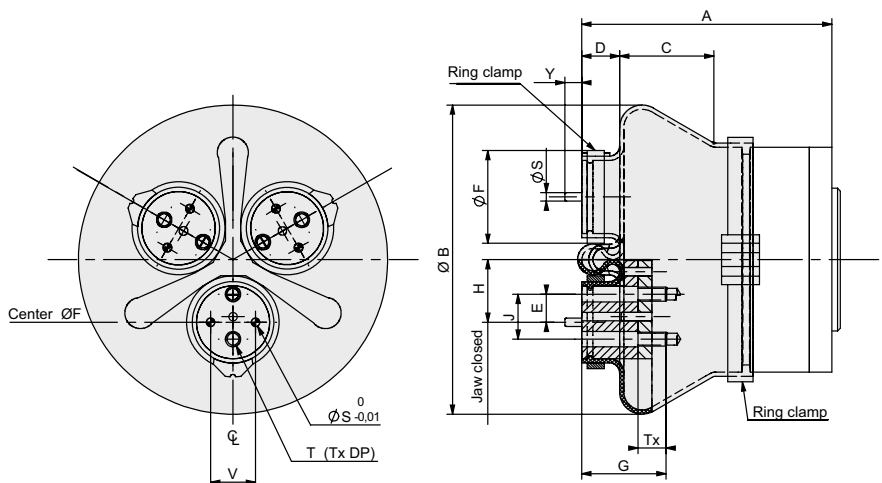

3P OPTIONS & ACCESSORIES

3-Jaw Parallel Grippers | Dimensions and Technical Specifications

11003P

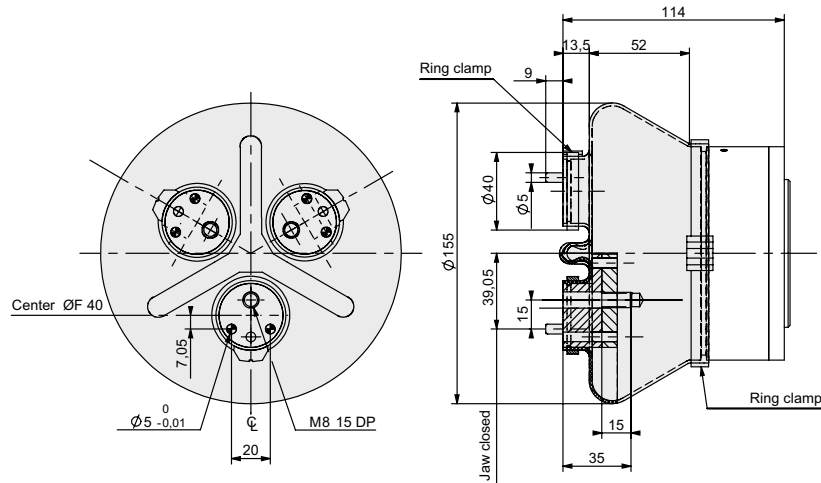

14003P & 16503P

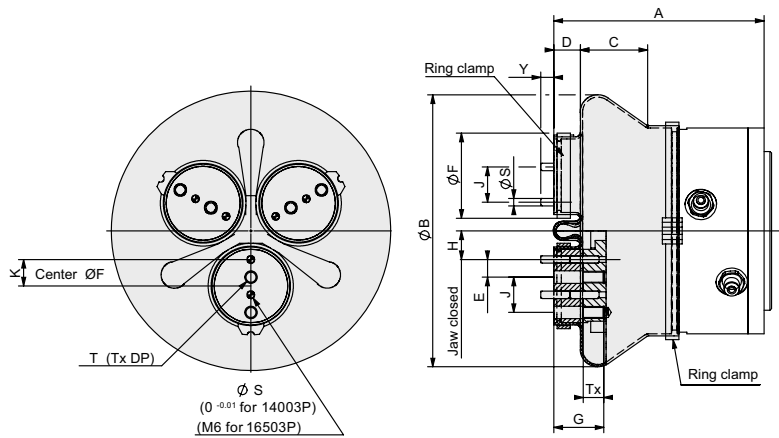

Accessory (SD): Inductive Sensor Mounting Kit

Allows for sensing of two positions: open and closed jaw. The accessory kit (SD) includes: 1 sensor bracket, 1 flag and screws. **Sensors are not provided.**

NOTES: To be usable, the cylindrical inductive sensors selected by the customer must have tapped their bodies to a minimum depth H (see table below).

Depending on their length, the cylindrical inductive sensors can extend below the clamp, requiring provision of suitable housing in the surrounding parts. It is possible to control more than 2 positions using a second attachment (SD).

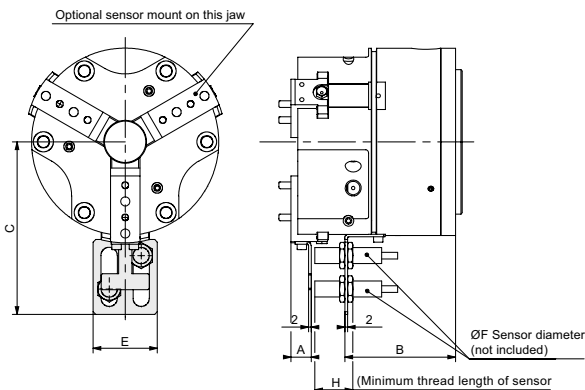

Order #	Model	A	B	C	E	F	H
SD60-80P	6003P & 6003P-C	20	35	67	32	8	35
SD60-80P	8003P & 8003P-C	19	34	77	32	8	35
SD110P	11003P & 11003P-C	19.5	45	97	32	8	35
OSMK-114	14003P & 14003P-C	15	83	129	48	12	28.5
OSMK-115	16503P & 16503P-C	29	96	147	48	12	33

RTH SERIES

3-Jaw Parallel Grippers | Features and Benefits | How To Order

Features:

- Rugged multi-purpose powerful gripper
- 8 sizes for small lightweight to very large and heavy part gripping
- High impact resistant with triple wedge design
- Shielded gripper to repel metal chips/particulates
- Spring assist option maintains grip in case of air pressure loss
- Purge and scavenge ports for harsh & clean environments
- Multi-position sensing up to 3 locations

Applications:

- Large round shaped parts
- Automotive engine block and gantry systems
- Ideal for very heavy part gripping



(USB key shown for scale)

How To Order

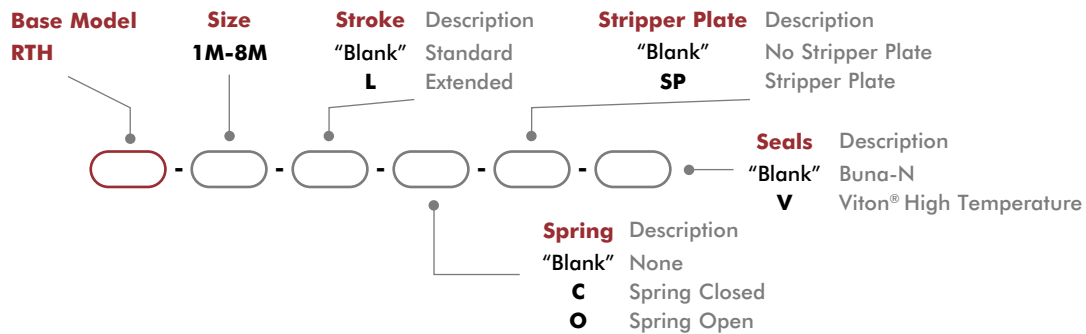

Accessories

Sensor Accessories	Model Numbers	Part Number	Qty/Unit
8mm PNP Magneto Resistive Sensor (90° barrel) w/ M8 Qk. Disc*	All Models	OHSP-011	1-3 [†]
8mm NPN Magneto Resistive Sensor (90° barrel) w/ M8 Qk. Disc*	All Models	OHSN-011	1-3 [†]
8mm PNP Magneto Resistive Sensor Short Barrel w/ M8 Qk Disc*	All Models	OHSP-017	1-3 [†]
8mm NPN Magneto Resistive Sensor Short Barrel w/ M8 Qk Disc*	All Models	OHSN-017	1-3 [†]
8mm PNP Inductive Sensor w/ M12 Quick Disconnect*	RTH-4M, -5M, -6M	OISP-011	1-3
8mm NPN Inductive Sensor w/ M12 Quick Disconnect*	RTH-4M, -5M, -6M	OISN-011	1-3
12mm PNP Inductive Sensor w/ M12 Quick Disconnect*	RTH-7M, -8M	OISP-017	1-3
12mm NPN Inductive Sensor w/ M12 Quick Disconnect*	RTH-7M, -8M	OISN-017	1-3
M8 Quick Disconnect 2 Meter Cable Length*	All Models	CABL-010	1-3
M8 Quick Disconnect 5 Meter Cable Length*	All Models	CABL-013	1-3
M12 Quick Disconnect 2 Meter Cable Length*	RTH-7M, -8M	CABL-014	1-3 [†]
M12 Quick Disconnect 5 Meter Cable Length*	RTH-7M, -8M	CABL-018	1-3 [†]

Pneumatic Accessories	Model Numbers	Part Number	Qty/Unit
M5 Adjustable Flow Control	RTH-1M, -2M, -3M	VLVF-008	1-2
G 1/8" 90° Adjustable Flow Control	RTH-4M, -5M, -6M, -7M	VLVF-005	1-2
G 1/4" Adjustable Flow Control	RDH-8M	VLVF-010	1-2

* Sensor and cable sold separately. [†] Except RTH-1, 1-2 only.

3-Jaw Heavy-Duty Parallel Grippers | Technical Specifications

Specifications	Units	1M	1M-L	2M	2M-L	3M	3M-L	4M	4M-L
Total Rated Grip Force F @ 100 psi [7 bar] w/o Spring Assist	N [lbs]	682 [153]	443 [100]	1238 [278]	812 [183]	2078 [467]	1349 [303]	3644 [819]	2366 [532]
Total Rated Grip Force F @ 100 psi [7 bar] with Spring Assist	N [lbs]	889 [200]	579 [130]	1490 [335]	979 [220]	2627 [591]	1708 [384]	4562 [1026]	2967 [667]
Total Stroke	mm [in]	4 [0.16]	8 [0.32]	6 [0.24]	12 [0.47]	8 [0.31]	16 [0.63]	10 [0.39]	20 [0.79]
Weight	kg [lbs]	0.25 [0.6]		0.53 [1.2]		1.08 [2.4]		1.95 [4.3]	
Pressure Range w/o Spring	bar [psi]	2-7 [30-100]							
Pressure Range with Spring	bar [psi]	4-7 [60-100]				3.5-7 [50-100]		3-7 [45-100]	
Max. Vacuum for Scavenge Port	mm Hg [in Hg]	200 [8]							
Max. Pressure for Purge Port	bar [psi]	2.1 [30]							
Ingress Protection Class (IP)		IP55							
Displacement	cm ³ [in ³]	6.5 [0.40]		17 [1.05]		37 [2.30]		80 [4.90]	
Temperature Range (Buna-N seals)	°C [°F]	-35°~80° [-30°~180°]							
Temperature Range (Viton® seals)	°C [°F]	-30°~150° [-20°~300°]							
Actuation (open/close)	sec.	0.06		0.07		0.08		0.1	
Accuracy	mm [in]	±0.04 [±0.002]				±0.06 [±0.0024]		±0.03 [±0.0012]	
Repeatability	mm [in]	±0.02 [±0.001]				±0.03 [±0.0012]		±0.04 [±0.0016]	
Valve to Actuate Single Acting		3-way, 2-position							
Valve to Actuate Double Acting		4-way, 2-position							

Specifications (cont.)	Units	5M	5M-L	6M	6M-L	7M	7M-L	8M	8M-L
Total Rated Grip Force F @ 100 psi [7 bar] w/o Spring Assist	N [lbs]	6353 [1428]	4125 [927]	10202 [2294]	6629 [1490]	17165 [3859]	11102 [2496]	35288 [7933]	22784 [5122]
Total Rated Grip Force F @ 100 psi [7 bar] with Spring Assist	N [lbs]	7877 [1771]	5124 [1152]	13786 [3099]	8971 [2017]	22093 [4967]	14322 [3222]	44354 [9971]	28690 [6450]
Total Stroke	mm [in]	13 [0.51]	26 [1.02]	16 [0.63]	32 [1.26]	25 [0.98]	50 [1.97]	35 [1.38]	70 [2.76]
Weight	kg [lbs]	3.9 [8.6]		7.89 [17.4]		15.7 [34.6]		43.9 [96.8]	
Pressure Range w/o Spring	bar [psi]	2-7 [30-100]							
Pressure Range with Spring	bar [psi]	3-7 [45-100]		4-7 [55-100]				3.5-7 [50-100]	
Max. Vacuum for Scavenge Port	mm Hg [in Hg]	20 [8]							
Max. Pressure for Purge Port	bar [psi]	2.1 [30]							
Ingress Protection Class (IP)		IP55							
Displacement	cm ³ [in ³]	180 [11.0]		355 [22]		940 [57]		2720 [166]	
Temperature Range (Buna-N seals)	°C [°F]	-35°~80° [-30°~180°]							
Temperature Range (Viton® seals)	°C [°F]	-30°~150° [-20°~300°]							
Actuation (open/close)	sec.	0.19		0.236		0.85		1.7	
Accuracy	mm [in]	±0.06 [±0.0024]		±0.08 [±0.0031]		±0.1 [±0.0039]		±0.05 [±0.002]	
Repeatability	mm [in]	±0.03 [±0.0012]		±0.04 [±0.0016]		±0.05 [±0.002]		±0.06 [±0.0024]	
Valve to Actuate Single Acting		3-way, 2-position							
Valve to Actuate Double Acting		4-way, 2-position							

RTH-1M, -1M-L

3-Jaw Parallel Grippers | Dimensions and Technical Specifications

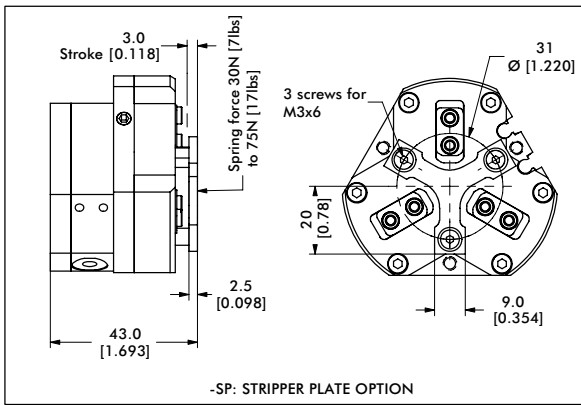
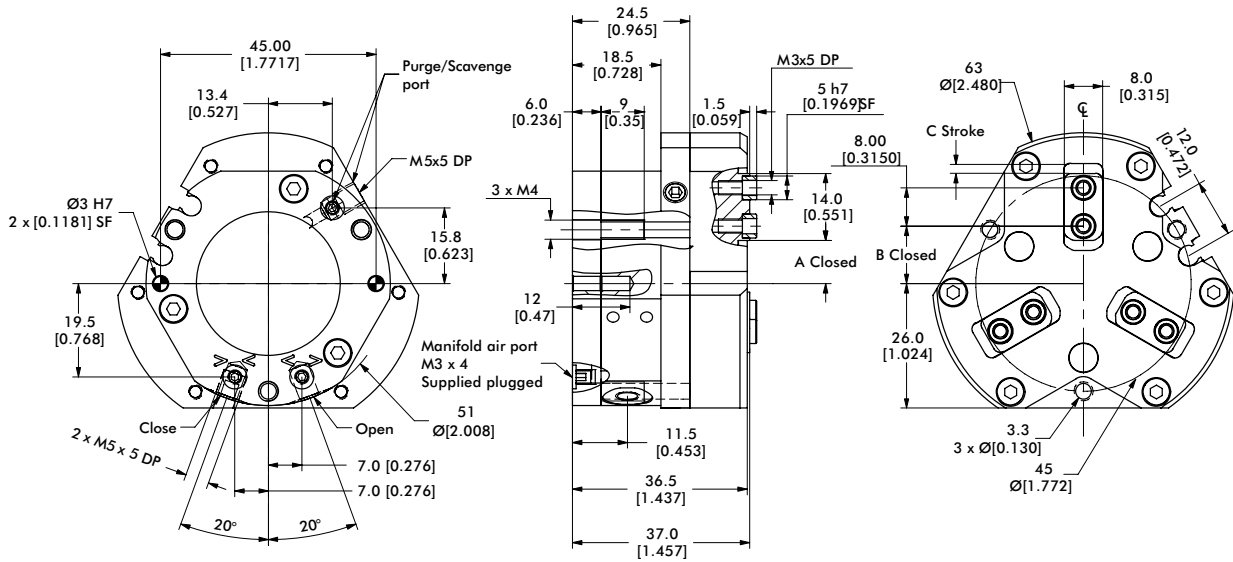

mm [INCH]

 THIRD ANGLE PROJECTION

Model	A	B	C
RTH-1M	9.0 [0.354]	12.0 [0.472]	2.0 [0.08]
RTH-1M-L	7.0 [0.276]	10.0 [0.394]	4.1 [0.16]

Dimensions in mm [in]

Seal Repair Kits	RTH-1M
Buna-N Seal Repair Kit	SLKT-347
Buna-N Rear Inlet Seal Repair Kit	SLKT-363
Viton® Seal Repair Kit	SLKT-347V
Viton® Rear Inlet Seal Repair Kit	SLKT-363V

Loading Information

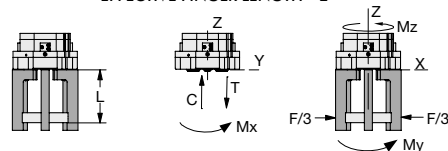
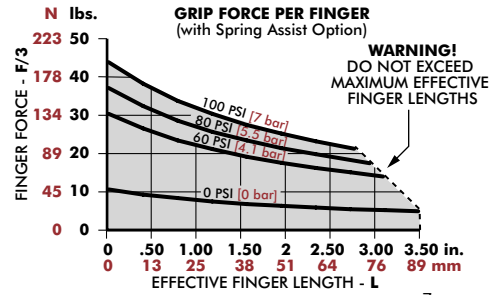
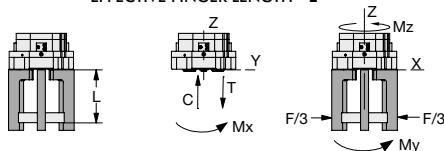
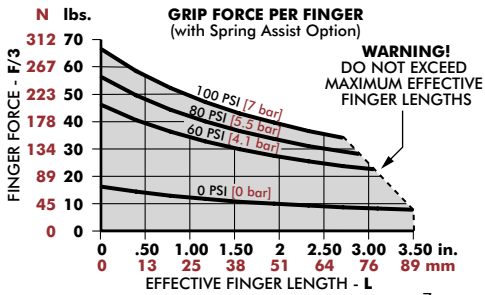

RTH-1M	Static	Dynamic
Maximum Tensile T	810 N [182 lbs]	89 N [20 lbs]
Maximum Compressive C	1060 N [238 lbs]	89 N [20 lbs]
Maximum Moment M_x	22 Nm [195 in-lbs]	2 Nm [18 in-lbs]
Maximum Moment M_y	28 Nm [248 in-lbs]	3 Nm [27 in-lbs]
Maximum Moment M_z	18 Nm [159 in-lbs]	3 Nm [27 in-lbs]

*Capacities are per set of jaws and are not simultaneous

RTH-1M-L	Static	Dynamic
Maximum Tensile T	730 N [164 lbs]	57 N [13 lbs]
Maximum Compressive C	960 N [216 lbs]	57 N [13 lbs]
Maximum Moment M_x	20 Nm [177 in-lbs]	1 Nm [9 in-lbs]
Maximum Moment M_y	23 Nm [204 in-lbs]	1 Nm [9 in-lbs]
Maximum Moment M_z	15 Nm [133 in-lbs]	1 Nm [9 in-lbs]

*Capacities are per set of jaws and are not simultaneous

RTH-2M, -2M-L

3-Jaw Parallel Grippers | Dimensions and Technical Specifications

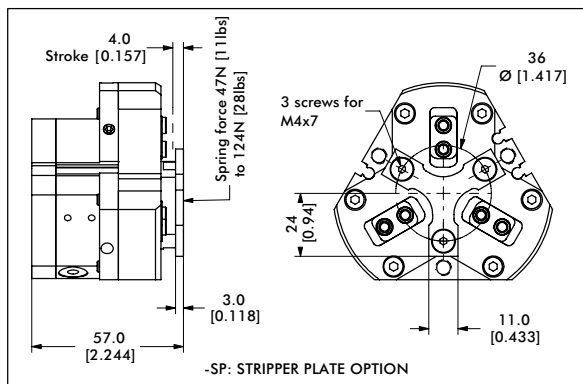
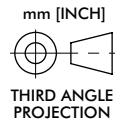
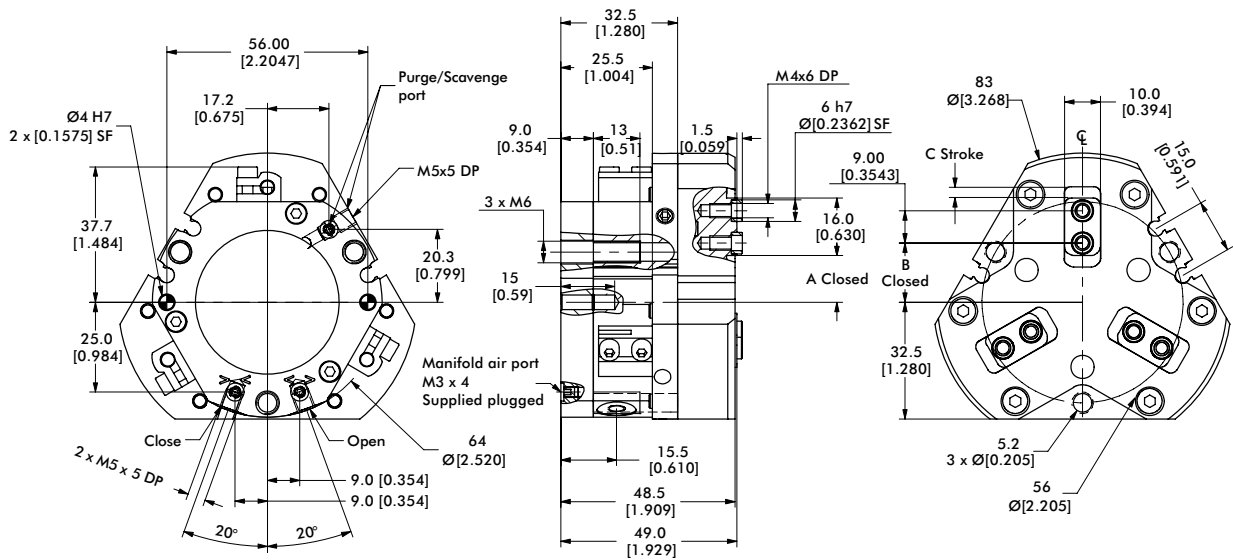

Model	A	B	C
RTH-2M	13.0 [0.512]	16.5 [0.650]	3.0 [0.12]
RTH-2M-L	10.0 [0.394]	13.5 [0.531]	6.0 [0.24]

Dimensions in mm [in]

Seal Repair Kits	RTH-2M
Buna-N Seal Repair Kit	SLKT-348
Buna-N Rear Inlet Seal Repair Kit	SLKT-363
Viton® Seal Repair Kit	SLKT-4348V
Viton® Rear Inlet Seal Repair Kit	SLKT-363V

Loading Information

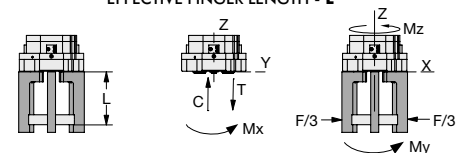
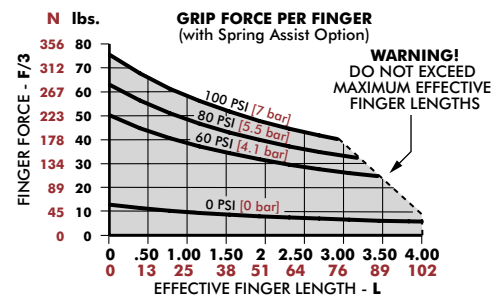
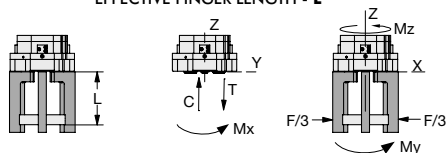
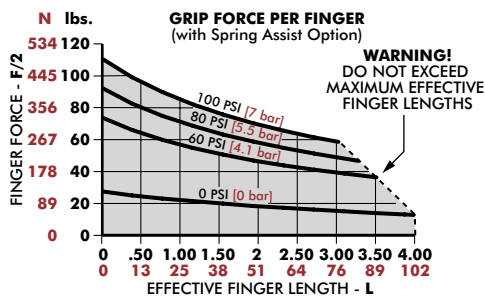

RTH-2M	Static	Dynamic
Maximum Tensile T	1200 N [270 lbs]	129 N [29 lbs]
Maximum Compressive C	1560 N [351 lbs]	129 N [29 lbs]
Maximum Moment M_x	45 Nm [398 in-lbs]	4 Nm [35 in-lbs]
Maximum Moment M_y	64 Nm [566 in-lbs]	6 Nm [53 in-lbs]
Maximum Moment M_z	41 Nm [363 in-lbs]	6 Nm [53 in-lbs]

*Capacities are per set of jaws and are not simultaneous

RTH-2M-L	Static	Dynamic
Maximum Tensile T	1080 N [243 lbs]	84 N [19 lbs]
Maximum Compressive C	1400 N [315 lbs]	84 N [19 lbs]
Maximum Moment M_x	40 Nm [354 in-lbs]	3 Nm [27 in-lbs]
Maximum Moment M_y	52 Nm [460 in-lbs]	4 Nm [35 in-lbs]
Maximum Moment M_z	33 Nm [292 in-lbs]	4 Nm [35 in-lbs]

*Capacities are per set of jaws and are not simultaneous

RTH-3M, -3M-L

3-Jaw Parallel Grippers | Dimensions and Technical Specifications

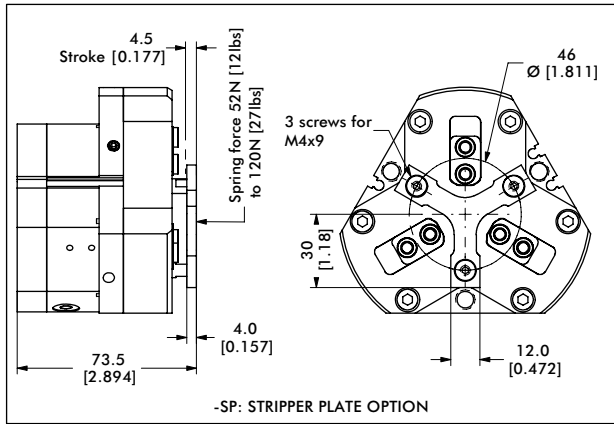
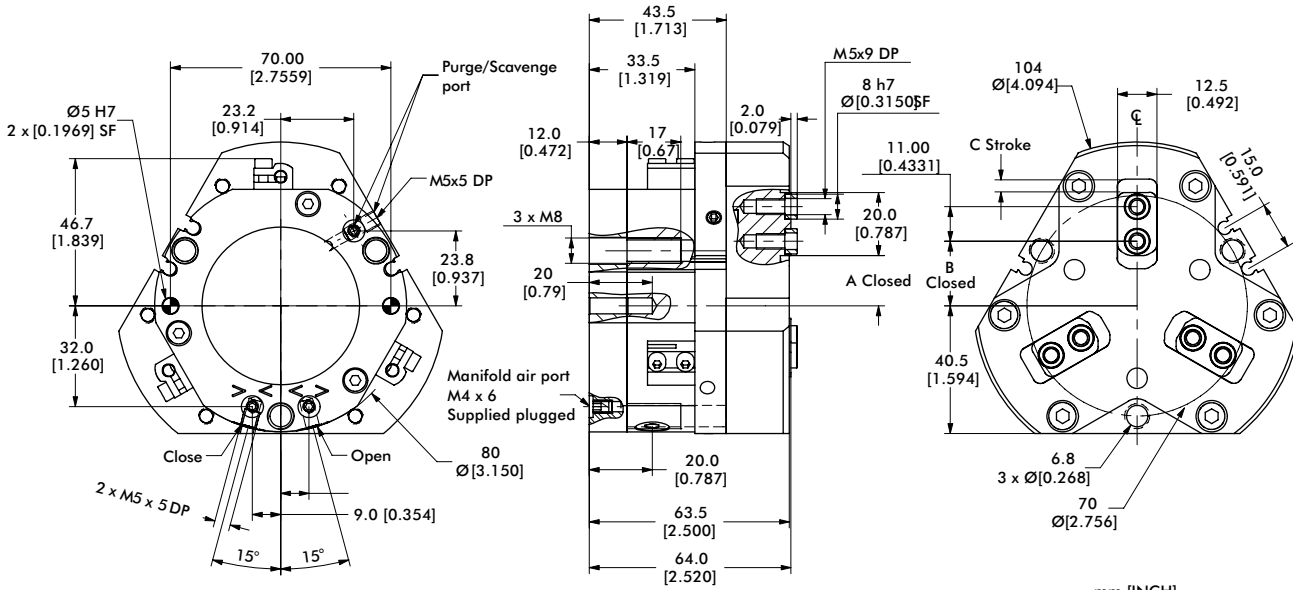

mm [INCH]
THIRD ANGLE PROJECTION

Model	A	B	C
RTH-3M	16.0 [0.630]	20.5 [0.807]	3.9 [0.16]
RTH-3M-L	12.0 [0.742]	16.5 [0.650]	8.0 [0.32]

Dimensions in mm [in]

Seal Repair Kits	RTH-3M
Buna-N Seal Repair Kit	SLKT-349
Buna-N Rear Inlet Seal Repair Kit	SLKT-364
Viton® Seal Repair Kit	SLKT-349V
Viton® Rear Inlet Seal Repair Kit	SLKT-364V

Loading Information

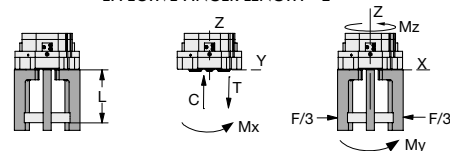
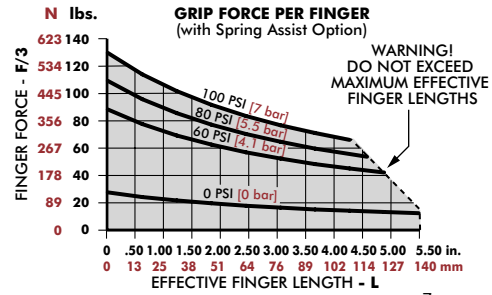
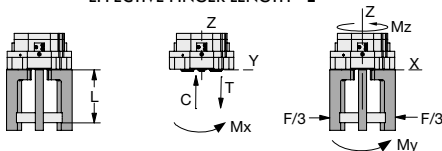
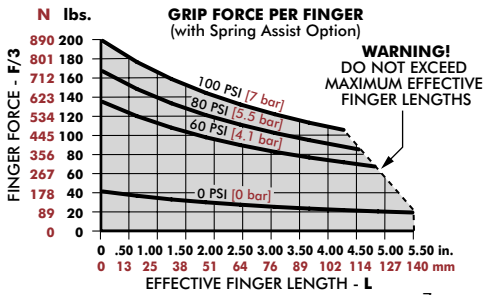

RTH-3M	Static	Dynamic
Maximum Tensile T	1680 N [378 lbs]	302 N [68 lbs]
Maximum Compressive C	2180 N [490 lbs]	302 N [68 lbs]
Maximum Moment M_x	72 Nm [637 in-lbs]	11 Nm [97 in-lbs]
Maximum Moment M_y	102 Nm [903 in-lbs]	16 Nm [142 in-lbs]
Maximum Moment M_z	66 Nm [584 in-lbs]	16 Nm [142 in-lbs]

[†]Capacities are per set of jaws and are not simultaneous

RTH-3M-L	Static	Dynamic
Maximum Tensile T	1500 N [337 lbs]	197 N [44 lbs]
Maximum Compressive C	1940 N [436 lbs]	197 N [44 lbs]
Maximum Moment M_x	64 Nm [566 in-lbs]	7 Nm [62 in-lbs]
Maximum Moment M_y	81 Nm [717 in-lbs]	9 Nm [80 in-lbs]
Maximum Moment M_z	53 Nm [469 in-lbs]	9 Nm [80 in-lbs]

[†]Capacities are per set of jaws and are not simultaneous

RTH-4M, -4M-L

3-Jaw Parallel Grippers | Dimensions and Technical Specifications

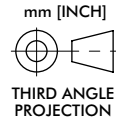
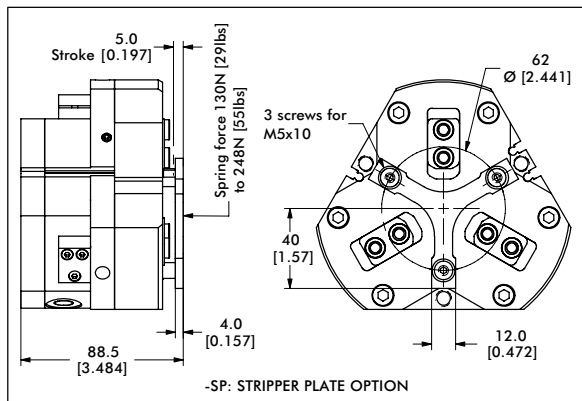
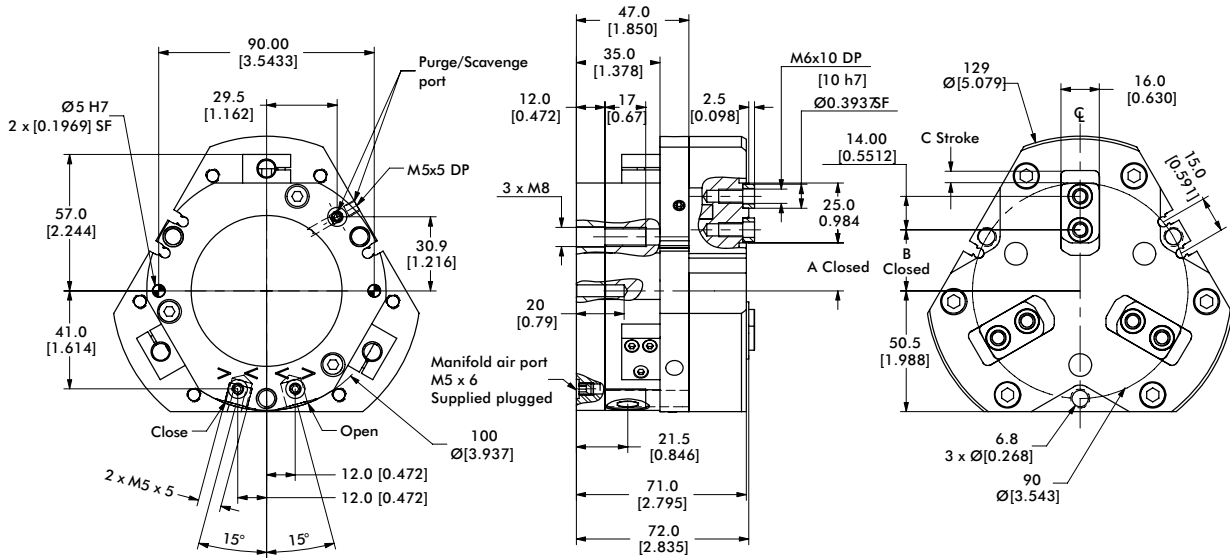

Model	A	B	C
RTH-4M	20.0 [0.787]	25.5 [1.004]	5.0 [0.20]
RTH-4M-L	15.0 [0.591]	20.5 [0.807]	10.0 [0.40]

Dimensions in mm [in]

Seal Repair Kits	RTH-4M
Buna-N Seal Repair Kit	SLKT-350
Buna-N Rear Inlet Seal Repair Kit	SLKT-365
Viton® Seal Repair Kit	SLKT-350V
Viton® Rear Inlet Seal Repair Kit	SLKT-365V

Loading Information

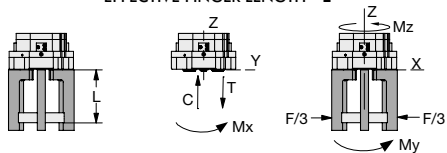
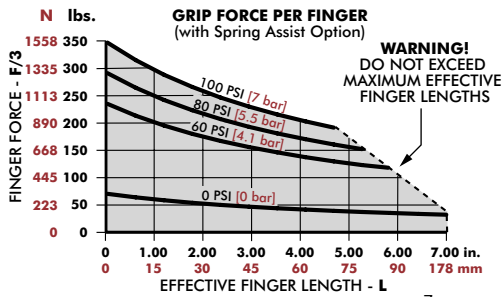

RTH-4M	Static	Dynamic
Maximum Tensile T	2110 N [474 lbs]	425 N [96 lbs]
Maximum Compressive C	2790 N [627 lbs]	425 N [96 lbs]
Maximum Moment M_x	92 Nm [814 in-lbs]	16 Nm [142 in-lbs]
Maximum Moment M_y	182 Nm [1133 in-lbs]	22 Nm [195 in-lbs]
Maximum Moment M_z	84 Nm [734 in-lbs]	22 Nm [195 in-lbs]

*Capacities are per set of jaws and are not simultaneous

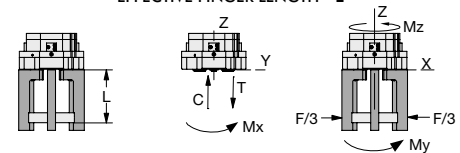
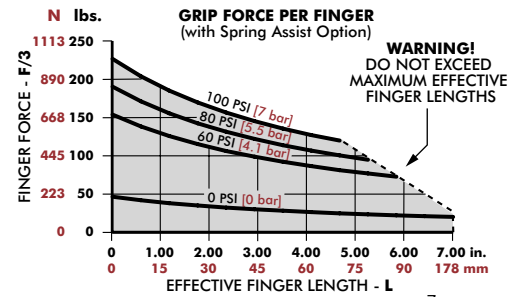

RTH-4M-L	Static	Dynamic
Maximum Tensile T	1880 N [423 lbs]	275 N [62 lbs]
Maximum Compressive C	2490 N [560 lbs]	275 N [62 lbs]
Maximum Moment M_x	82 Nm [726 in-lbs]	10 Nm [89 in-lbs]
Maximum Moment M_y	102 Nm [903 in-lbs]	13 Nm [115 in-lbs]
Maximum Moment M_z	67 Nm [593 in-lbs]	13 Nm [115 in-lbs]

*Capacities are per set of jaws and are not simultaneous

RTH-6M, -6M-L

3-Jaw Parallel Grippers | Dimensions and Technical Specifications

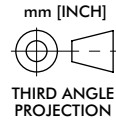
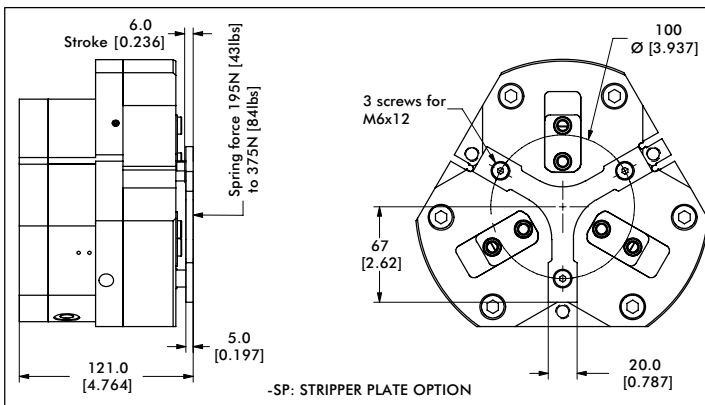
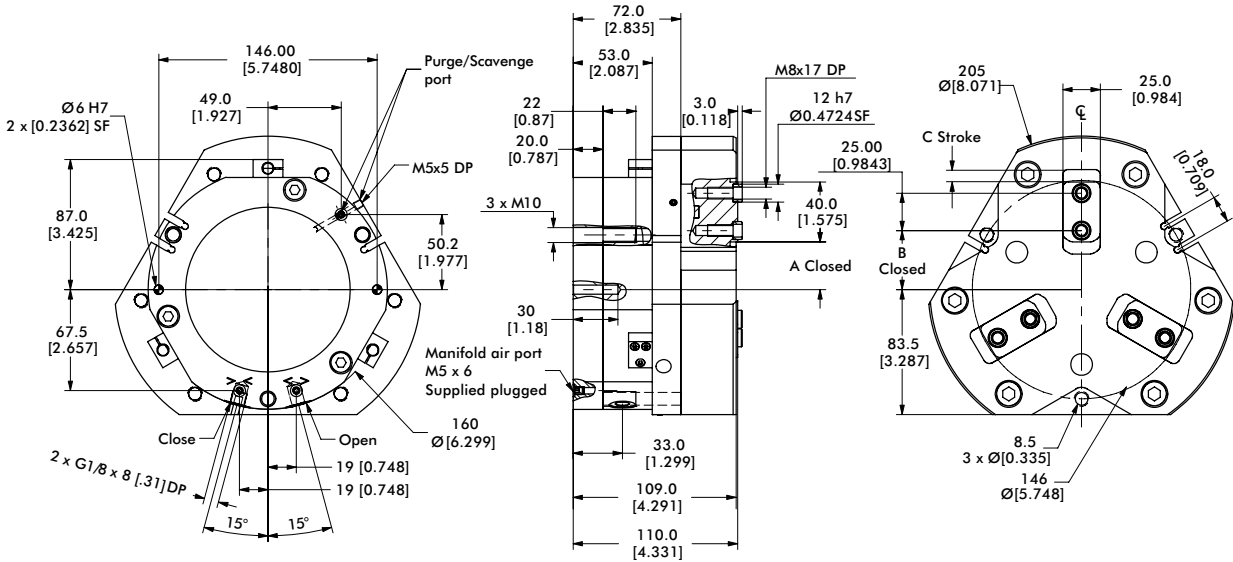

Model	A	B	C
RTH-6M	32.0 [1.260]	39.5 [1.555]	8.0 [0.32]
RTH-6M-L	24.0 [0.945]	31.5 [1.240]	16.0 [0.63]

Dimensions in mm [in]

Seal Repair Kits	RTH-6M
Buna-N Seal Repair Kit	SLKT-352
Buna-N Rear Inlet Seal Repair Kit	SLKT-365
Viton® Seal Repair Kit	SLKT-352V
Viton® Rear Inlet Seal Repair Kit	SLKT-365V

Loading Information

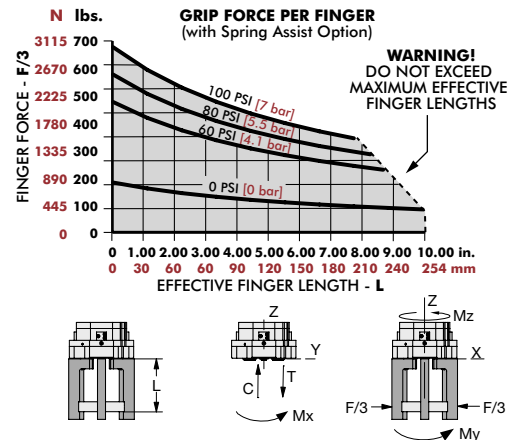
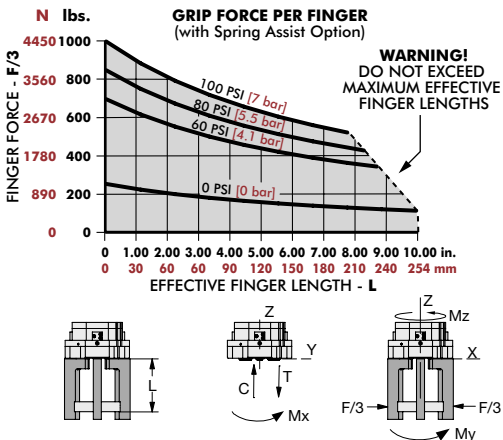

RTH-6M	Static	Dynamic
Maximum Tensile T	4320 N [971 lbs]	1315 N [296 lbs]
Maximum Compressive C	5810 N [1306 lbs]	1315 N [296 lbs]
Maximum Moment M_x	172 Nm [1522 in-lbs]	45 Nm [398 in-lbs]
Maximum Moment M_y	250 Nm [2213 in-lbs]	65 Nm [575 in-lbs]
Maximum Moment M_z	164 Nm [1452 in-lbs]	65 Nm [575 in-lbs]

RTH-6M-L	Static	Dynamic
Maximum Tensile T	3860 N [868 lbs]	852 N [192 lbs]
Maximum Compressive C	5180 N [1165 lbs]	852 N [192 lbs]
Maximum Moment M_x	154 Nm [1363 in-lbs]	29 Nm [257 in-lbs]
Maximum Moment M_y	199 Nm [1761 in-lbs]	37 Nm [327 in-lbs]
Maximum Moment M_z	131 Nm [1159 in-lbs]	37 Nm [327 in-lbs]

*Capacities are per set of jaws and are not simultaneous

*Capacities are per set of jaws and are not simultaneous

RTH-7M, -7M-L

3-Jaw Parallel Grippers | Dimensions and Technical Specifications

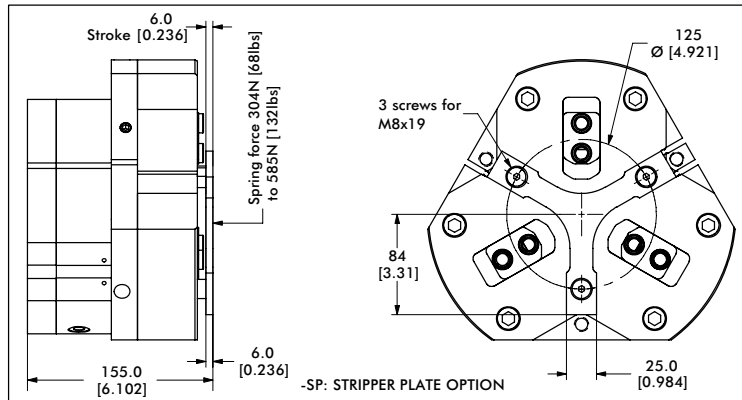
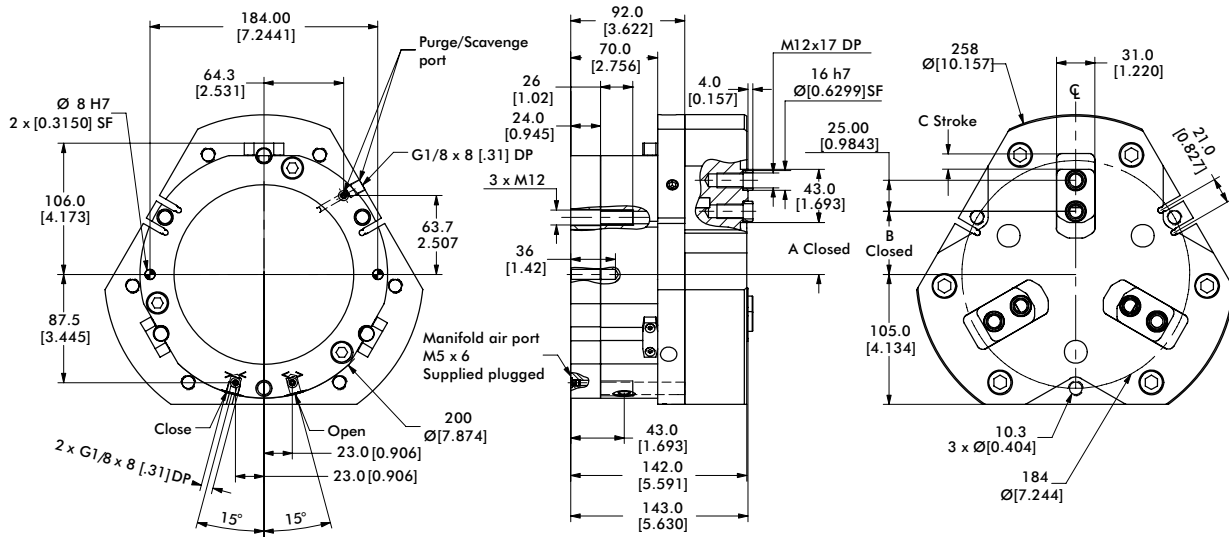

mm [INCH]
THIRD ANGLE PROJECTION

Model	A	B	C
RTH-7M	42.0 [1.654]	51.0 [2.008]	12.4 [0.49]
RTH-7M-L	29.5 [1.161]	38.5 [1.516]	25.0 [0.99]

Dimensions in mm [in]

Seal Repair Kits	RTH-7M
Buna-N Seal Repair Kit	SLKT-353
Buna-N Rear Inlet Seal Repair Kit	SLKT-365
Viton® Seal Repair Kit	SLKT-353V
Viton® Rear Inlet Seal Repair Kit	SLKT-365V

Loading Information

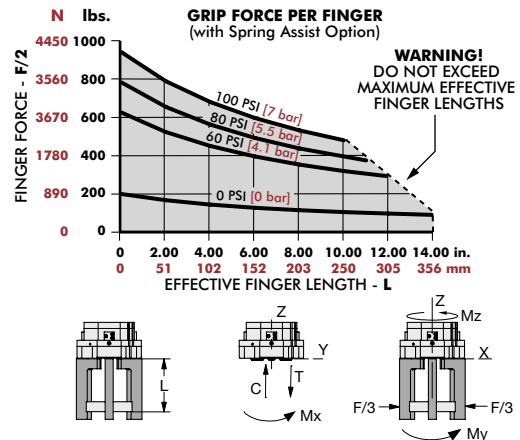
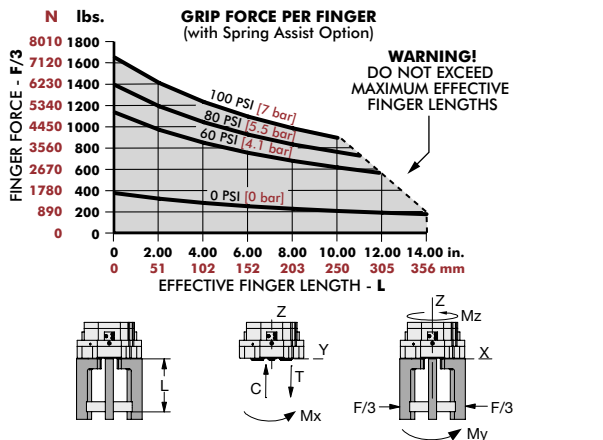

RTH-7M	Static	Dynamic
Maximum Tensile T	5400 N [1214 lbs]	1763 N [396 lbs]
Maximum Compressive C	7120 N [1601 lbs]	1763 N [396 lbs]
Maximum Moment M_x	215 Nm [1903 in-lbs]	60 Nm [531 in-lbs]
Maximum Moment M_y	305 Nm [2699 in-lbs]	86 Nm [761 in-lbs]
Maximum Moment M_z	208 Nm [1841 in-lbs]	86 Nm [761 in-lbs]

RTH-7M-L	Static	Dynamic
Maximum Tensile T	4690 N [1054 lbs]	1141 N [257 lbs]
Maximum Compressive C	6180 N [1389 lbs]	1141 N [257 lbs]
Maximum Moment M_x	186 Nm [1646 in-lbs]	39 Nm [345 in-lbs]
Maximum Moment M_y	230 Nm [2036 in-lbs]	48 Nm [425 in-lbs]
Maximum Moment M_z	156 Nm [1381 in-lbs]	48 Nm [425 in-lbs]

*Capacities are per set of jaws and are not simultaneous

*Capacities are per set of jaws and are not simultaneous

RTH-8M, -8M-L

3-Jaw Parallel Grippers | Dimensions and Technical Specifications

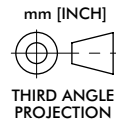
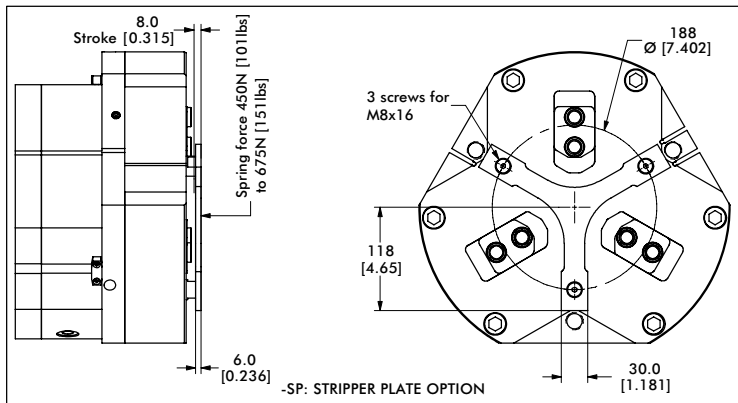
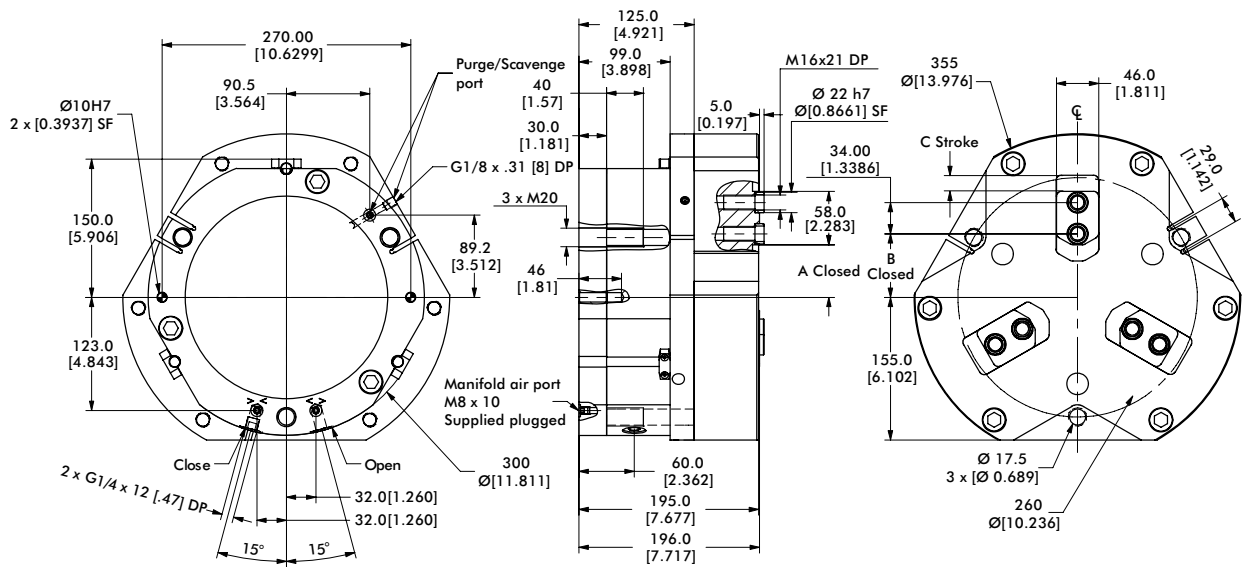

Model	A	B	C
RTH-8M	57.0 [2.244]	69.0 [2.717]	17.7 [0.70]
RTH-8M-L	39.5 [1.555]	51.5 [2.028]	35.1 [1.38]

Dimensions in mm [in]

Seal Repair Kits	RTH-8M
Buna-N Seal Repair Kit	SLKT-354
Buna-N Rear Inlet Seal Repair Kit	SLKT-366
Viton® Seal Repair Kit	SLKT-354V
Viton® Rear Inlet Seal Repair Kit	SLKT-366V

Loading Information

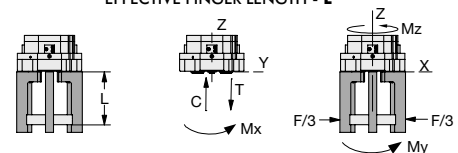
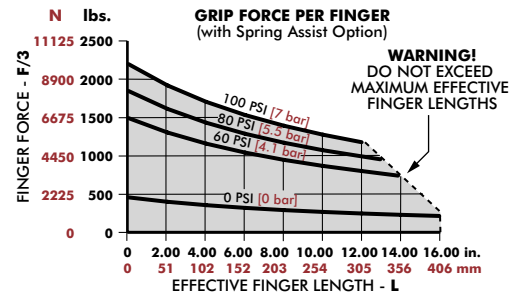
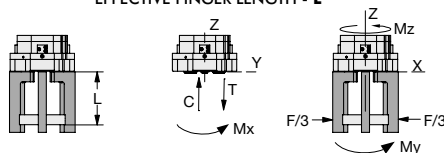
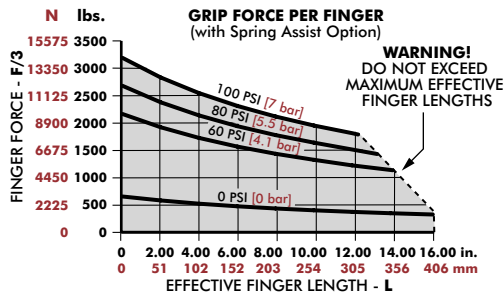

RTH-8M	Static	Dynamic
Maximum Tensile T	8230 N [1850 lbs]	2733 N [614 lbs]
Maximum Compressive C	10700 N [2405 lbs]	2733 N [614 lbs]
Maximum Moment M_x	455 Nm [4027 in-lbs]	131 Nm [1159 in-lbs]
Maximum Moment M_y	578 Nm [5116 in-lbs]	167 Nm [1478 in-lbs]
Maximum Moment M_z	362 Nm [3204 in-lbs]	167 Nm [1478 in-lbs]

*Capacities are per set of jaws and are not simultaneous

RTH-8M-L	Static	Dynamic
Maximum Tensile T	7080 N [1592 lbs]	1772 N [398 lbs]
Maximum Compressive C	9210 N [2070 lbs]	1772 N [398 lbs]
Maximum Moment M_x	391 Nm [3461 in-lbs]	85 Nm [752 in-lbs]
Maximum Moment M_y	428 Nm [3788 in-lbs]	93 Nm [823 in-lbs]
Maximum Moment M_z	268 Nm [2372 in-lbs]	93 Nm [823 in-lbs]

*Capacities are per set of jaws and are not simultaneous

PPC SERIES

3-Jaw Parallel Grippers | Features and Benefits | How To Order

Features:

- Multipurpose robust gripper with high repeatability
- Through-hole design for 3rd party tooling, imaging, part ejectors, hoses and sensing.
- Spring assist option maintains grip in case of air pressure loss
- Grip force range from 1474N to 4332N
- Repeatability of +/-0.02mm

Applications:

- Feed thru work piece applications
- Optical workpiece inspection via center hole
- Part feed/ejection, part cleaning, part presence



How To Order

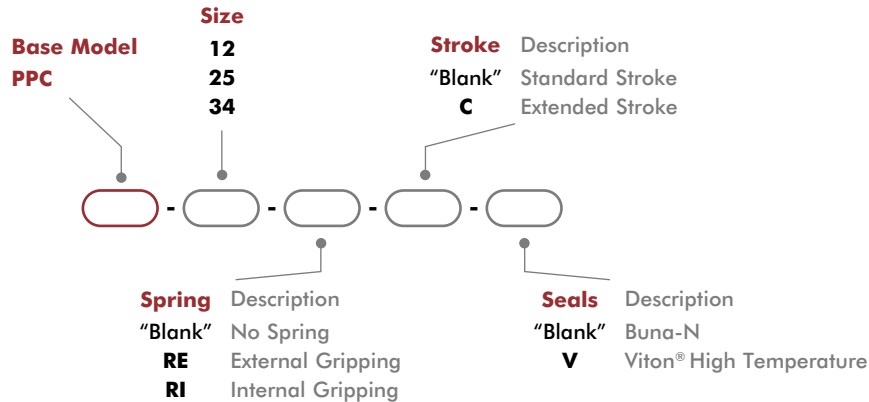

Accessories

Sensor Accessories	Model Numbers	Part Number	Qty/Unit
Inductive Sensor Mounting Kit (1 Holder, 1 Flag, 2 Spacers)	PPC-12	OSMK-105	1-2
Inductive Sensor Mounting Kit (1 Holder, 1 Flag, 2 Spacers)	PPC-25	OSMK-106	1-2
Inductive Sensor Mounting Kit (1 Holder, 1 Flag, 2 Spacers)	PPC-34	OSMK-107	1-2
NPN Inductive Sensor with Quick Disconnect*	All Models	OISP-011	1-4
PNP Inductive Sensor with Quick Disconnect*	All Models	OISP-011	1-4
Quick Disconnect Cable (2 meters long)*	All Models	CABL-010	1-4
Quick Disconnect Cable (5 meters long)*	All Models	CABL-013	1-4

*Sensor and cable sold separately.

3-Jaw Parallel Grippers | Technical Specifications

Specifications	Units	12	12-C	25	25-C
Total Rated Grip Force F @ 100 psi [7 bar]*	N [lbs]	1474 [331]	896 [201]	2620 [589]	1642 [369]
Total Stroke	mm [in]	10 [0.394]	16 [0.630]	13 [0.512]	20 [0.787]
Weight	kg [lbs]	1.0 [2.2]	1.1 [2.4]	2.2 [4.9]	2.3 [5.1]
Pressure Range (without spring)	bar [psi]	2-7 [30-100]			
Pressure Range (with spring)	bar [psi]	3-7 [45-100]			
Ingress Protection Class (IP)		IP54			
Displacement	cm ³ [in ³]	23 [1.40]		51 [3.11]	
Temperature Range (Buna-N seals)	°C [°F]	-35°~80° [-30°~180°]			
Temperature Range (Viton® seals)	°C [°F]	-30°~150° [-20°~300°]			
Actuation	sec.	0.03		0.04	
Repeatability	mm [in]	±0.02 [±0.0008]			

*With springs

Specifications	Units	34	34-C
Total Rated Grip Force F @ 100 psi [7 bar]*	N [lbs]	4332 [974]	2938 [638]
Total Stroke	mm [in]	20 [0.787]	30 [1.181]
Weight	kg [lbs]	5.1 [11.2]	5.3 [11.7]
Pressure Range (without spring)	bar [psi]	2-7 [30-100]	
Pressure Range (with spring)	bar [psi]	3-7 [45-100]	
Ingress Protection Class (IP)		IP54	
Displacement	cm ³ [in ³]	128 [7.81]	
Temperature Range (Buna-N seals)	°C [°F]	-35°~80° [-30°~180°]	
Temperature Range (Viton® seals)	°C [°F]	-30°~150° [-20°~300°]	
Actuation	sec.	0.06	
Repeatability	mm [in]	±0.02 [±0.0008]	

*With springs

PPC-12, -12-C

3-Jaw Parallel Grippers | Dimensions and Technical Specifications

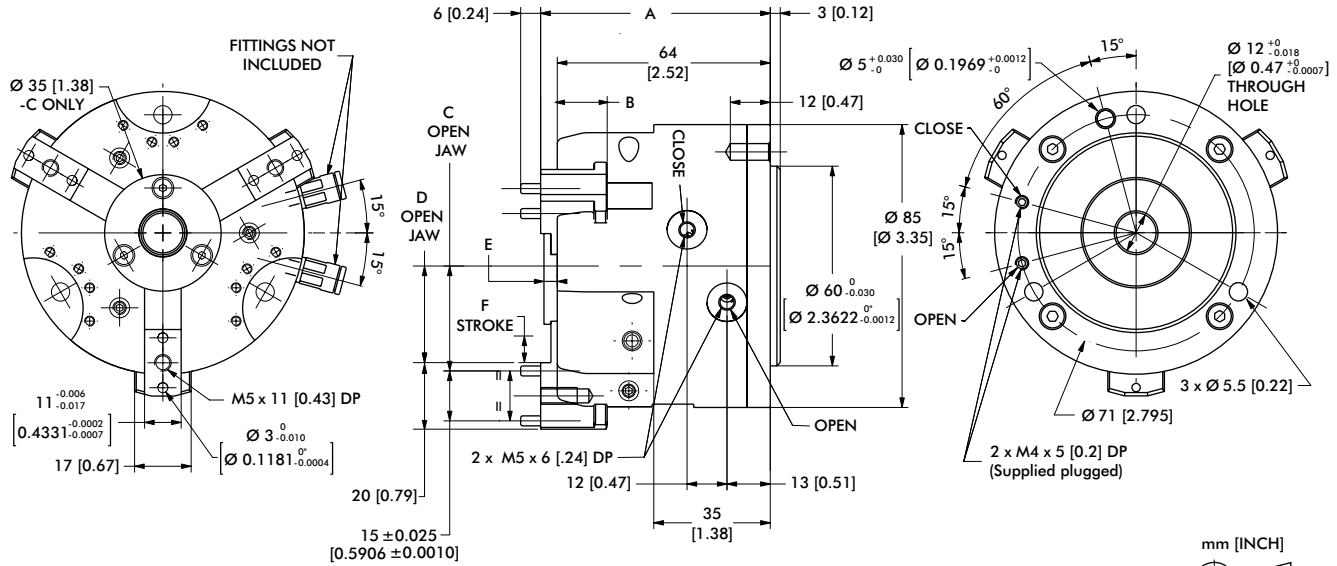
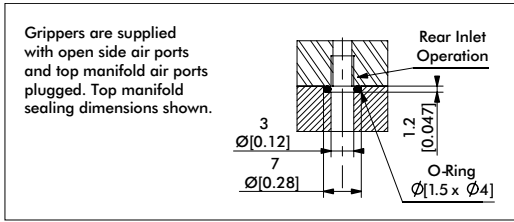

Model	A	B	C	D	E	F
PPC-12	65 [2.56]	64 [2.52]	25.5 [1.004]	23 [0.906]	--	5 [0.2]
PPC-12-C	69 [2.72]	64 [2.52]	31.5 [1.241]	29.03 [1.143]	4 [0.16]	8 [0.31]

Dimensions in mm [in]

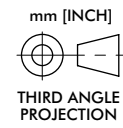

Loading Information

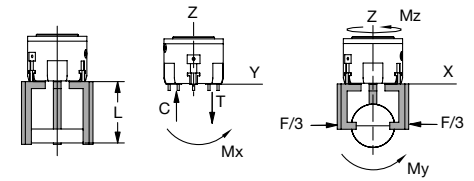
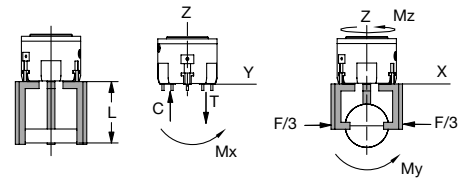
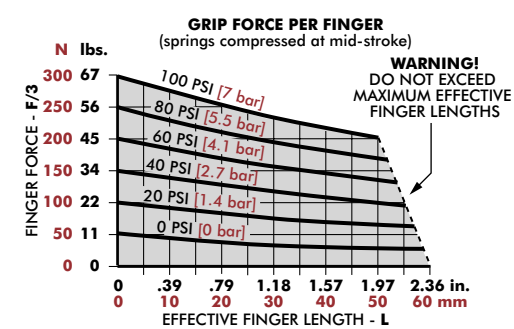
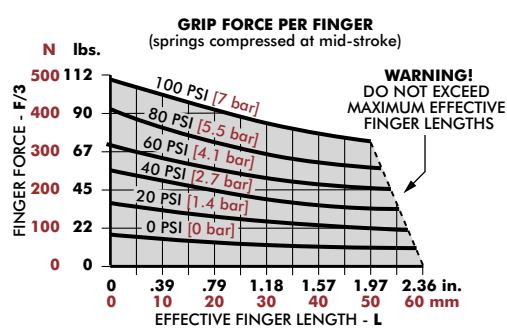

	Static	Dynamic
Maximum Tensile T	850 N [191 lbs]	220 N [49 lbs]
Maximum Compressive C	1150 N [259 lbs]	220 N [49 lbs]
Maximum Moment M_x	20 Nm [177 in-lbs]	6 Nm [53 in-lbs]
Maximum Moment M_y	20 Nm [177 in-lbs]	6 Nm [53 in-lbs]
Maximum Moment M_z	50 Nm [443 in-lbs]	10 Nm [89 in-lbs]

*Capacities are per set of jaws and are not simultaneous

	Static	Dynamic
Maximum Tensile T	[214 lbs] 950 N	220 N [49 lbs]
Maximum Compressive C	[281 in-lbs] 1250 N	220 N [49 lbs]
Maximum Moment M_x	[177 in-lbs] 20 Nm	6 Nm [53 in-lbs]
Maximum Moment M_y	[177 in-lbs] 20 Nm	6 Nm [53 in-lbs]
Maximum Moment M_z	[531 in-lbs] 60 Nm	10 Nm [89 in-lbs]

*Capacities are per set of jaws and are not simultaneous

3-Jaw Parallel Grippers | Dimensions and Technical Specifications

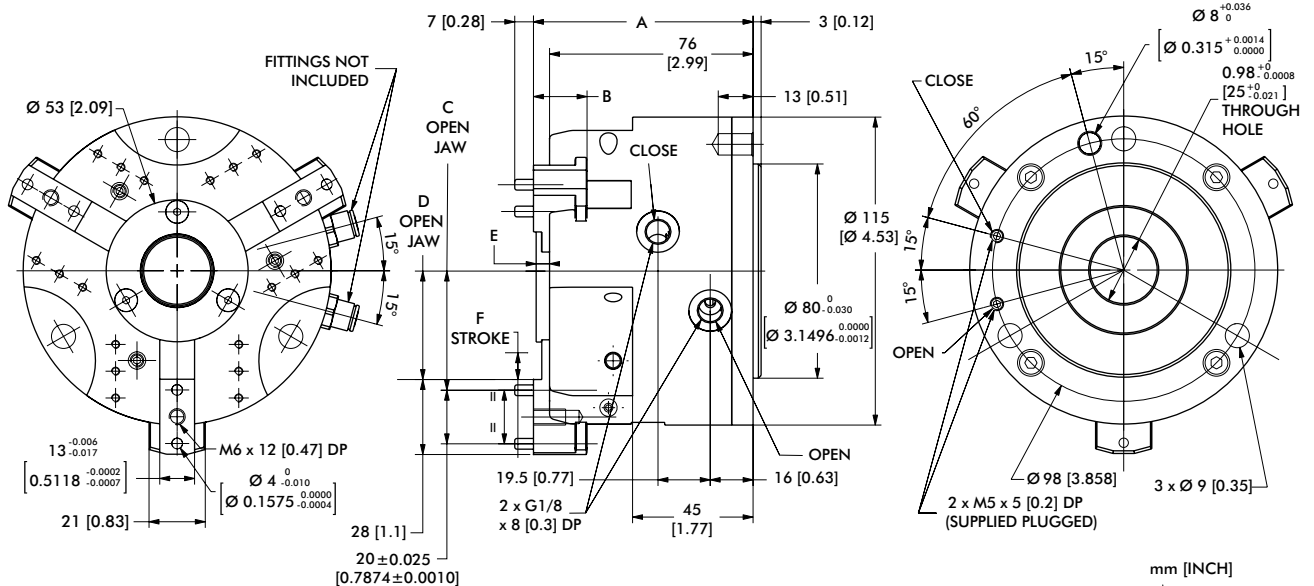
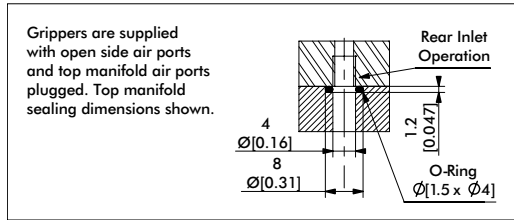

Loading Information

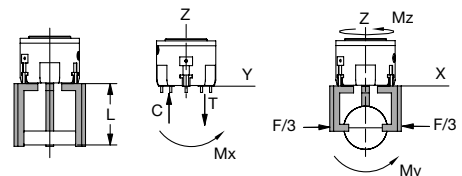
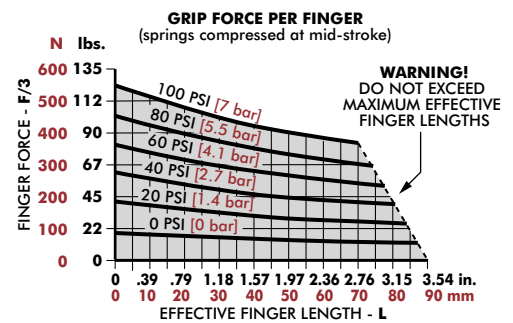
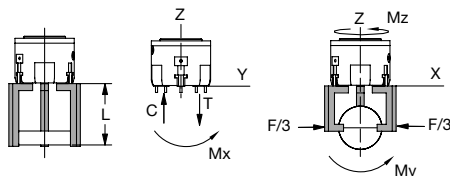
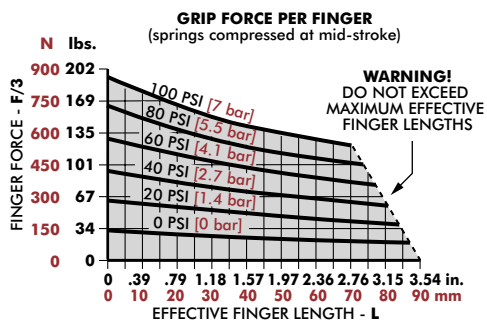

	Static	Dynamic
Maximum Tensile T	1300 N [292 lbs]	390 N [88 lbs]
Maximum Compressive C	1500 N [337 lbs]	390 N [88 lbs]
Maximum Moment M_x	30 Nm [266 in-lbs]	13 Nm [115 in-lbs]
Maximum Moment M_y	30 Nm [266 in-lbs]	13 Nm [115 in-lbs]
Maximum Moment M_z	65 Nm [575 in-lbs]	25 Nm [221 in-lbs]

*Capacities are per set of jaws and are not simultaneous

	Static	Dynamic
Maximum Tensile T	1300 N [292 lbs]	390 N [88 lbs]
Maximum Compressive C	1500 N [337 lbs]	390 N [88 lbs]
Maximum Moment M_x	30 Nm [266 in-lbs]	13 Nm [115 in-lbs]
Maximum Moment M_y	30 Nm [266 in-lbs]	13 Nm [115 in-lbs]
Maximum Moment M_z	70 Nm [620 in-lbs]	25 Nm [221 in-lbs]

*Capacities are per set of jaws and are not simultaneous

REP3 SERIES

3-Jaw Parallel Grippers | Features and Benefits | How To Order

Features:

- Multipurpose robust gripper with high repeatability
- Spring assist option maintains grip in case of air pressure loss
- Uses inductive or magneto resistive sensors for sensing jaw position
- Grip force range from 771N to 2235N
- Purge and scavenge ports for harsh & clean environments
- Repeatability of +/-0.02mm

Applications:

- Long cycle life requirements
- High vibration environments
- Pick and place, part feeds



How To Order

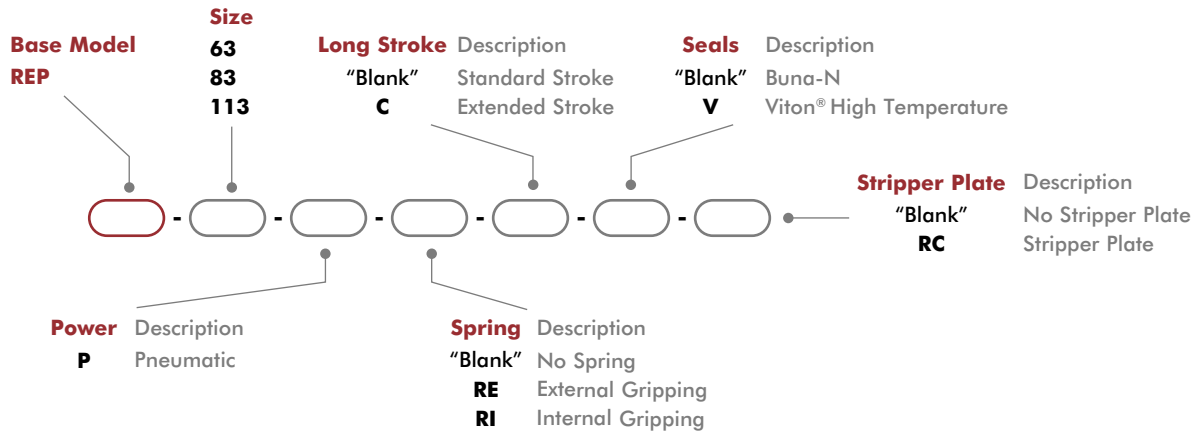

Accessories

Sensor Accessories	Model Numbers	Part Number	Qty/Unit
NPN Inductive Sensor with M8 Quick Disconnect*	All Models	OISN-011	1-4
PNP Inductive Sensor with M8 Quick Disconnect*	All Models	OISP-011	1-4
NPN Magneto Resistive Sensor with Quick Disconnect*	All Models	OHSN-006	1-2
PNP Magneto Resistive Sensor with Quick Disconnect*	All Models	OHSP-006	1-2
NPN Magneto Resistive Sensor (Short Barrel) with Qk Disconnect*	All Models	OHSN-017	1-2
PNP Magneto Resistive Sensor (Short Barrel) with Qk Disconnect*	All Models	OHSP-017	1-2
M8 Quick Disconnect 2 Meter Cable Length*	All Models	CABL-010	1-4
M8 Quick Disconnect 2 Meter Cable Length*	All Models	CABL-013	1-4
Inductive Sensor Mounting Kit (1 holder, 1 flag, 2 spacers)	63	OSMK-105	1-2
Inductive Sensor Mounting Kit (1 holder, 1 flag, 2 spacers)	83	OSMK-106	1-2
Inductive Sensor Mounting Kit (1 holder, 1 flag, 2 spacers)	113	OSMK-107	1-2

* Sensor and cable sold separately. †The gripper comes with adjustable slots for two magnetic sensors (to control jaw position). Must be used with the -RE or -RI option.

3-Jaw Parallel Grippers | Technical Specifications

Specifications	Units	63	63-C	83	83-C	113	113-C
Total Rated Grip Force F @ 100 psi [7 bar]*	N [lbs]	753 [169]	469 [105]	2077 [467]	1341 [301]	3268 [735]	2180 [490]
Total Stroke	mm [in]	10 [0.394]	16 [0.630]	13 [0.512]	20 [0.787]	20 [0.787]	30 [1.181]
Weight	kg [lbs]	0.55 [1.2]		0.9 [2.0]		2.45 [5.4]	
Pressure Range w/o Spring	bar [psi]	2-7 [30-100]					
Pressure Range with Spring	bar [psi]	3-7 [45-100]					
Ingress Protection Class (IP)		IP55					
Displacement	cm ³ [in ³]	12 [0.72]		35 [2.13]		87 [5.31]	
Temperature Range (Buna-N seals)	°C [°F]	-35°~80° [-30°~180°]					
Temperature Range (Viton® seals)	°C [°F]	-30°~150° [-20°~300°]					
Actuation (open/close)	sec.	0.10		0.18		0.35	
Accuracy	mm [in]	±0.05 [±0.002]					
Repeatability	mm [in]	±0.02 [±0.0008]					
Valve to Actuate Single Acting		3-way, 2-position					
Valve to Actuate Double Acting		4-way, 2-position					

* with springs

REP-63, -63-C

3-Jaw Parallel Grippers | Dimensions and Technical Specifications

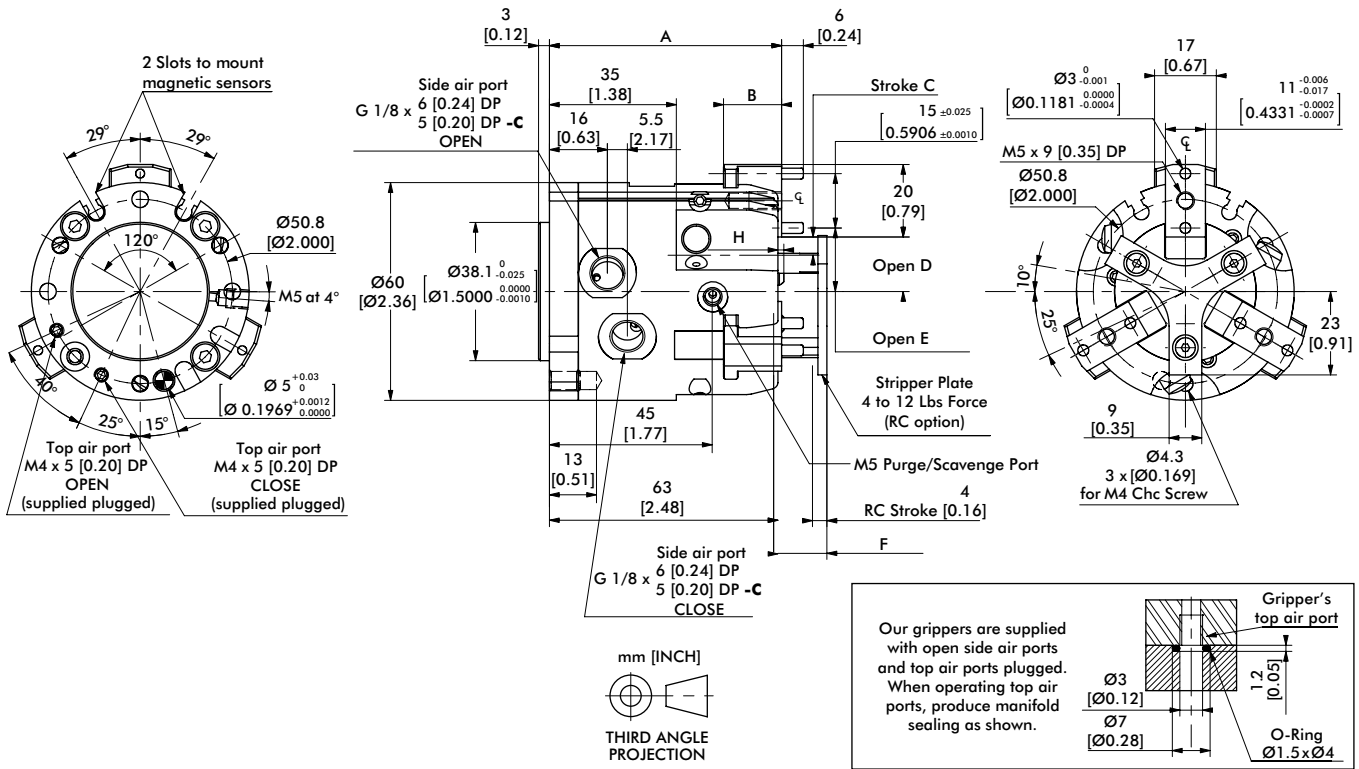

Model	A	B	C	D	E	F	H
REP-63	62 [2.52]	16 [0.63]	5 [0.20]	15 [0.59]	17.5 [0.689]	13.5 [0.531]	1.6 [0.06]
REP-63-C	68 [2.68]	20 [0.79]	8 [0.31]	21 [0.83]	23.5 [0.926]	17.5 [0.689]	5.6 [0.22]

Dimensions in mm [in]

Seal Repair Kits	REP-63
Buna-N Seal Repair Kit	SLKT-155
Viton® Seal Repair Kit	SLKT-155V

Loading Information

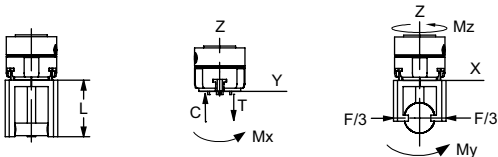
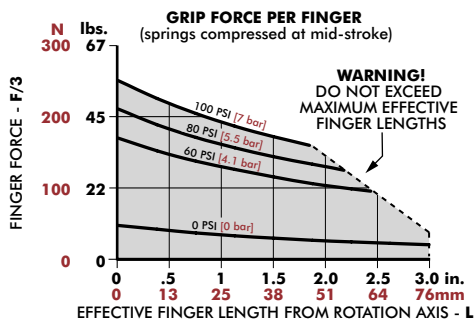

REP-63	Static
Maximum Tensile T	860 N [193 lbs]
Maximum Compressive C	1150 N [259 lbs]
Maximum Moment M_x	18 Nm [159 in-lbs]
Maximum Moment M_y	30 Nm [266 in-lbs]
Maximum Moment M_z	30 Nm [44 in-lbs]

†Capacities are per set of jaws and are not simultaneous

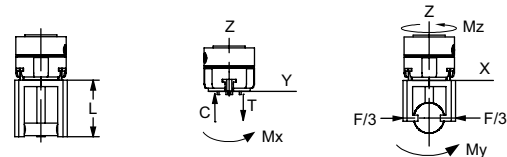
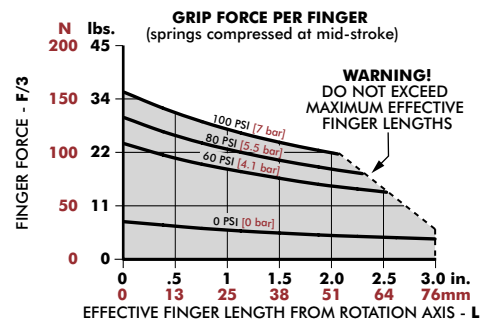

REP-63-C	Static
Maximum Tensile T	860 N [193 lbs]
Maximum Compressive C	1150 N [259 lbs]
Maximum Moment M_x	15 Nm [133 in-lbs]
Maximum Moment M_y	30 Nm [266 in-lbs]
Maximum Moment M_z	50 Nm [443 in-lbs]

†Capacities are per set of jaws and are not simultaneous

3-Jaw Parallel Grippers | Dimensions and Technical Specifications

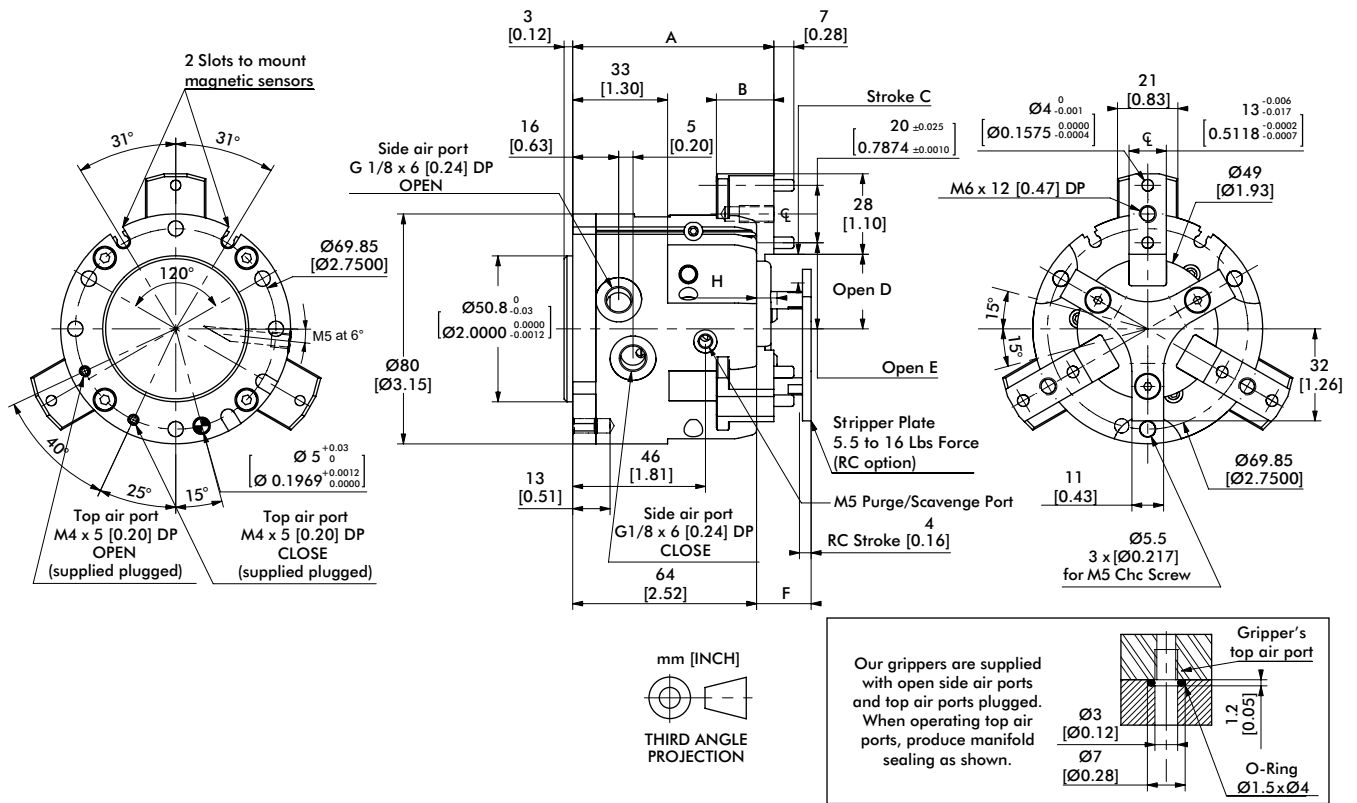

Model	A	B	C	D	E	F	H
REP-83	65 [2.56]	15 [0.59]	6.5 [0.256]	19 [0.75]	23 [0.91]	14 [0.55]	2.1 [0.08]
REP-83-C	70 [2.76]	20 [0.79]	10 [0.39]	26 [1.10]	30 [1.18]	19 [0.75]	7.1 [0.28]

Dimensions in mm [in]

Seal Repair Kits	REP-83
Buna-N Seal Repair Kit	SLKT-157
Viton® Seal Repair Kit	SLKT-157V

Loading Information

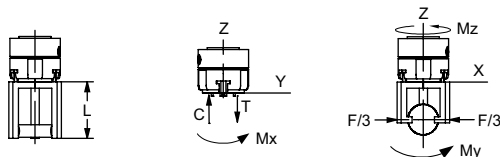
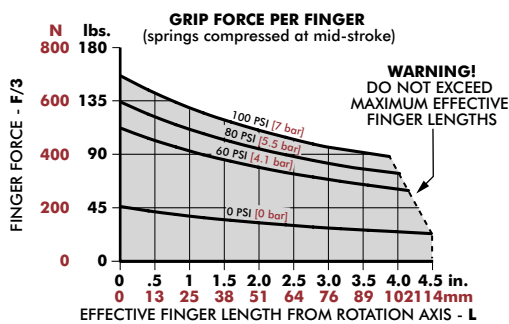

REP-83	Static
Maximum Tensile T	1250 N [281 lbs]
Maximum Compressive C	1400 N [315 lbs]
Maximum Moment M_x	30 Nm [266 in-lbs]
Maximum Moment M_y	55 Nm [487 in-lbs]
Maximum Moment M_z	60 Nm [531 in-lbs]

[†]Capacities are per set of jaws and are not simultaneous

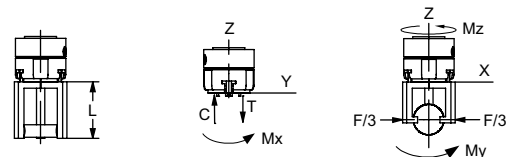
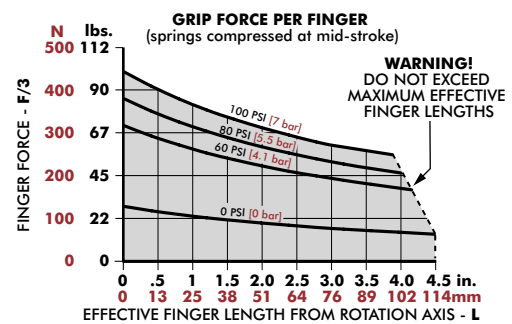

REP-83-C	Static
Maximum Tensile T	1210 N [272 lbs]
Maximum Compressive C	1360 N [306 lbs]
Maximum Moment M_x	25 Nm [221 in-lbs]
Maximum Moment M_y	50 Nm [443 in-lbs]
Maximum Moment M_z	60 Nm [531 in-lbs]

[†]Capacities are per set of jaws and are not simultaneous

REP-113, -113-C

3-Jaw Parallel Grippers | Dimensions and Technical Specifications

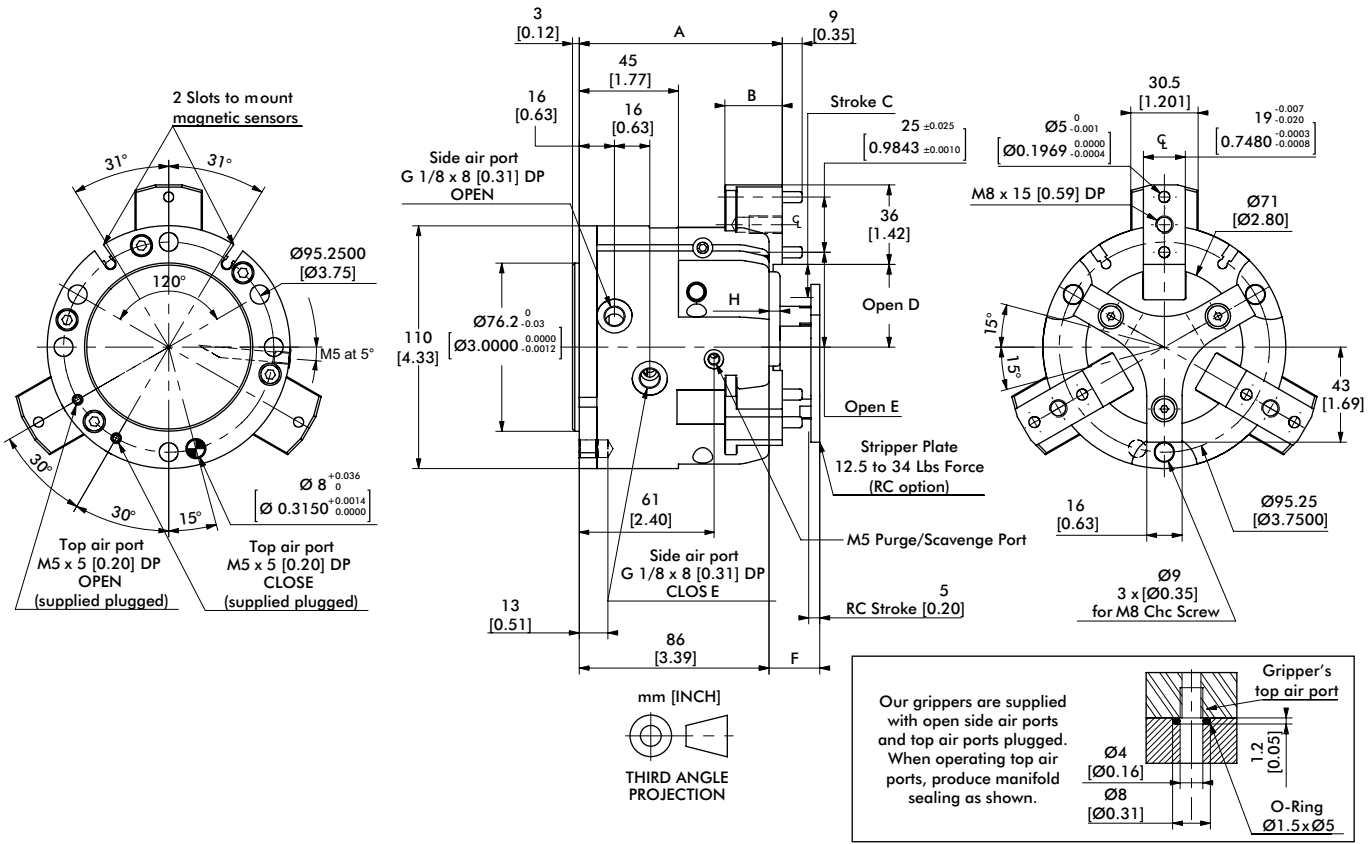

Model	A	B	C	D	E	F	H
REP-113	87 [3.43]	21 [0.83]	10 [0.39]	27.5 [1.083]	33 [1.30]	18 [0.71]	--
REP-113-C	92 [3.62]	26 [1.02]	15 [0.59]	37.5 [1.476]	43 [1.69]	23 [0.91]	5 [0.20]

Dimensions in mm [in]

Seal Repair Kits	REP-113
Buna-N Seal Repair Kit	SLKT-158
Viton® Seal Repair Kit	SLKT-158V

Loading Information

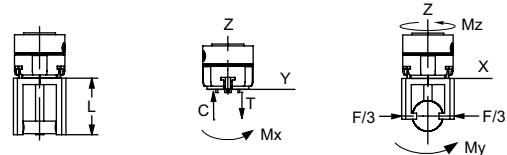
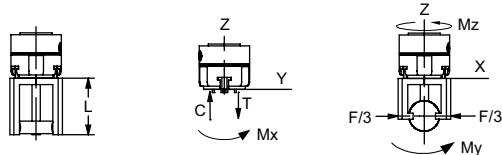
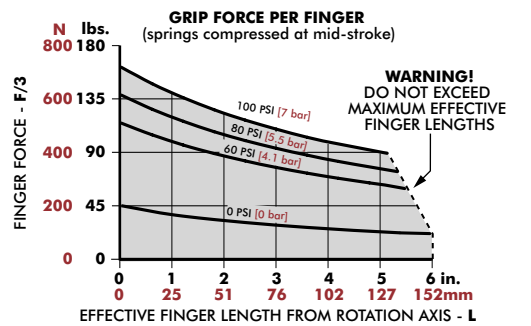
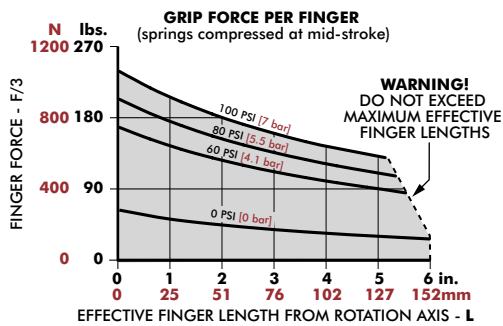

REP-113	Static
Maximum Tensile T	1980 N [445 lbs]
Maximum Compressive C	2150 N [483 lbs]
Maximum Moment M_x	58 Nm [513 in-lbs]
Maximum Moment M_y	100 Nm [885 in-lbs]
Maximum Moment M_z	110 Nm [974 in-lbs]

†Capacities are per set of jaws and are not simultaneous

REP-113-C	Static
Maximum Tensile T	1970 N [443 lbs]
Maximum Compressive C	2140 N [481 lbs]
Maximum Moment M_x	52 Nm [460 in-lbs]
Maximum Moment M_y	100 Nm [885 in-lbs]
Maximum Moment M_z	110 Nm [974 in-lbs]

†Capacities are per set of jaws and are not simultaneous

RPC SERIES

3-Jaw Parallel Grippers | Features and Benefits | How To Order

Features:

- Self-centering gripper with very high grip force
- Optional stripper plate for part insertion/ejection
- Ideal for gripping small to very large round parts
- Grip force range from 445N to 13345N
- Repeatability of +/-0.03mm

Applications:

- Part feed/ejection
- Lathe applications
- Large heavy round parts



How To Order

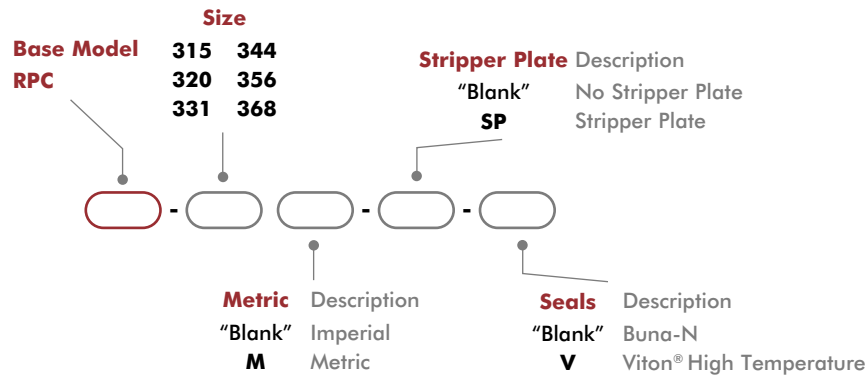

Accessories

Sensor Accessories	Model Numbers	Part Number	Qty/Unit
4mm NPN Magneto Resistive Sensor with Quick Disconnect*	All Models	OHSN-017	1-2
4mm PNP Magneto Resistive Sensor with Quick Disconnect*	All Models	OHSP-017	1-2
4mm NPN 90° Magneto Resistive Sensor with Quick Disconnect*	All Models	OHSN-011	1-2
4mm PNP 90° Magneto Resistive Sensor with Quick Disconnect*	All Models	OHSP-011	1-2
Quick Disconnect Cable (2 meters long)*	All Models	CABL-010	1-2
Quick Disconnect Cable (5 meters long)*	All Models	CABL-013	1-2
Fail Safe Valve (Imperial)	315, 320, 331	OFSV-001	1
Fail Safe Valve (Metric)	315, 320, 331	OFSV-004	1
Fail Safe Valve (Imperial)	344, 356, 368	OFSV-002	1
Fail Safe Valve (Metric)	344, 356, 368	OFSV-005	1

* Sensor and cable sold separately.

3-Jaw Parallel Grippers | Technical Specifications

Specifications	Units	315	320	331
Total Rated Grip Force F @ 100 psi [7 bar]*	N [lbs]	445 [100]	1334 [300]	3336 [750]
Total Stroke	mm [in]	7.6 [0.30]	10.2 [0.40]	15.7 [0.62]
Weight	kg [lbs]	0.24 [0.53]	0.45 [1.0]	1.4 [3.0]
Pressure Range	bar [psi]	1.4-7 [20-100]		
Ingress Protection Class (IP)		IP54		
Displacement	cm ³ [in ³]	5.2 [0.32]	17.7 [1.08]	52.3 [3.31]
Temperature Range (Buna-N seals)	°C [°F]	-35°~80° [-30°~180°]		
Temperature Range (Viton® seals)	°C [°F]	-30°~150° [-20°~300°]		
Actuation	sec.	0.12	0.18	0.23
Accuracy	mm [in]	±0.05 [±0.002]		
Repeatability	mm [in]	±0.03 [±0.001]		
Valve to Actuate Double Acting		4-way, 2-position		

*With springs

Specifications	Units	344	356	368
Total Rated Grip Force F @ 100 psi [7 bar]*	N [lbs]	4003 [900]	6339 [1425]	13345 [3000]
Total Stroke	mm [in]	22.2 [0.88]	28.4 [1.12]	34.9 [1.38]
Weight	kg [lbs]	2.7 [6.0]	4.4 [9.75]	7.3 [16]
Pressure Range	bar [psi]	1.4-7 [20-100]		
Ingress Protection Class (IP)		IP54		
Displacement	cm ³ [in ³]	120 [7.37]	253 [13.46]	424 [25.86]
Temperature Range (Buna-N seals)	°C [°F]	-35°~80° [-30°~180°]		
Temperature Range (Viton® seals)	°C [°F]	-30°~150° [-20°~300°]		
Actuation	sec.	0.47	0.50	0.74
Accuracy	mm [in]	±0.05 [±0.002]		
Repeatability	mm [in]	±0.03 [±0.001]		
Valve to Actuate Double Acting		4-way, 2-position		

*With springs

RPC-315

3-Jaw Parallel Grippers | Dimensions and Technical Specifications

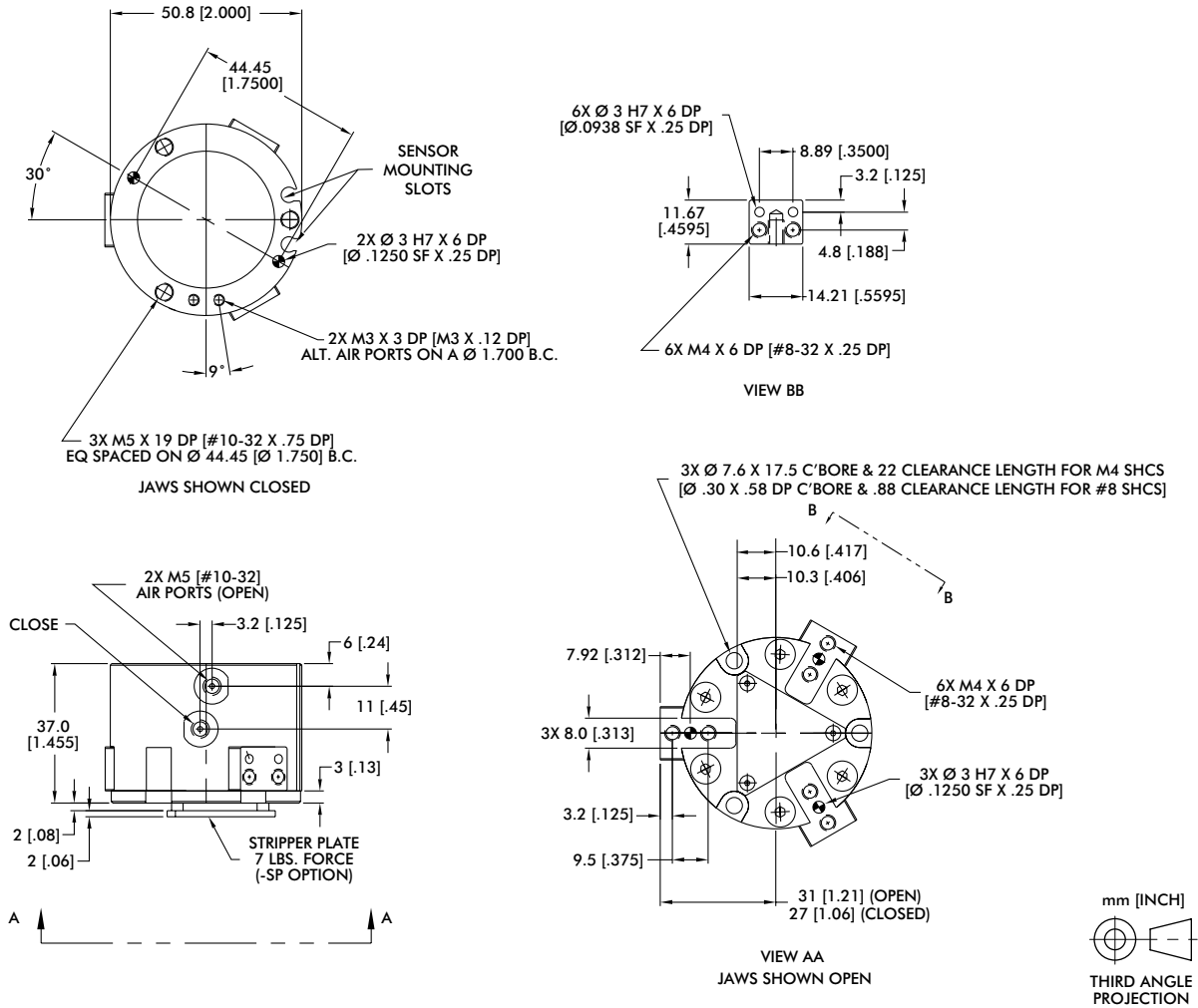

Loading Information

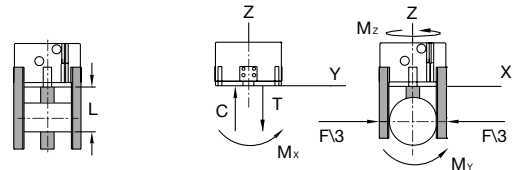
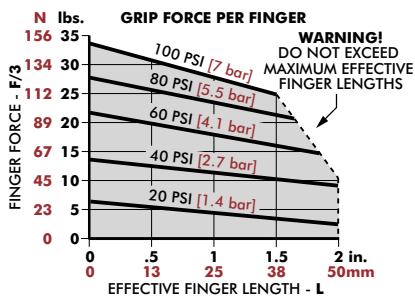

RPC-315	Static	Dynamic
Maximum Tensile T	1334 N [300 lbs]	445 N [100 lbs]
Maximum Compressive C	1334 N [300 lbs]	445 N [100 lbs]
Maximum Moment M_x	28 Nm [250 in-lbs]	8 Nm [75 in-lbs]
Maximum Moment M_y	28 Nm [250 in-lbs]	8 Nm [75 in-lbs]
Maximum Moment M_z	17 Nm [150 in-lbs]	6 Nm [50 in-lbs]

*Capacities are per set of jaws and are not simultaneous

3-Jaw Parallel Grippers | Dimensions and Technical Specifications

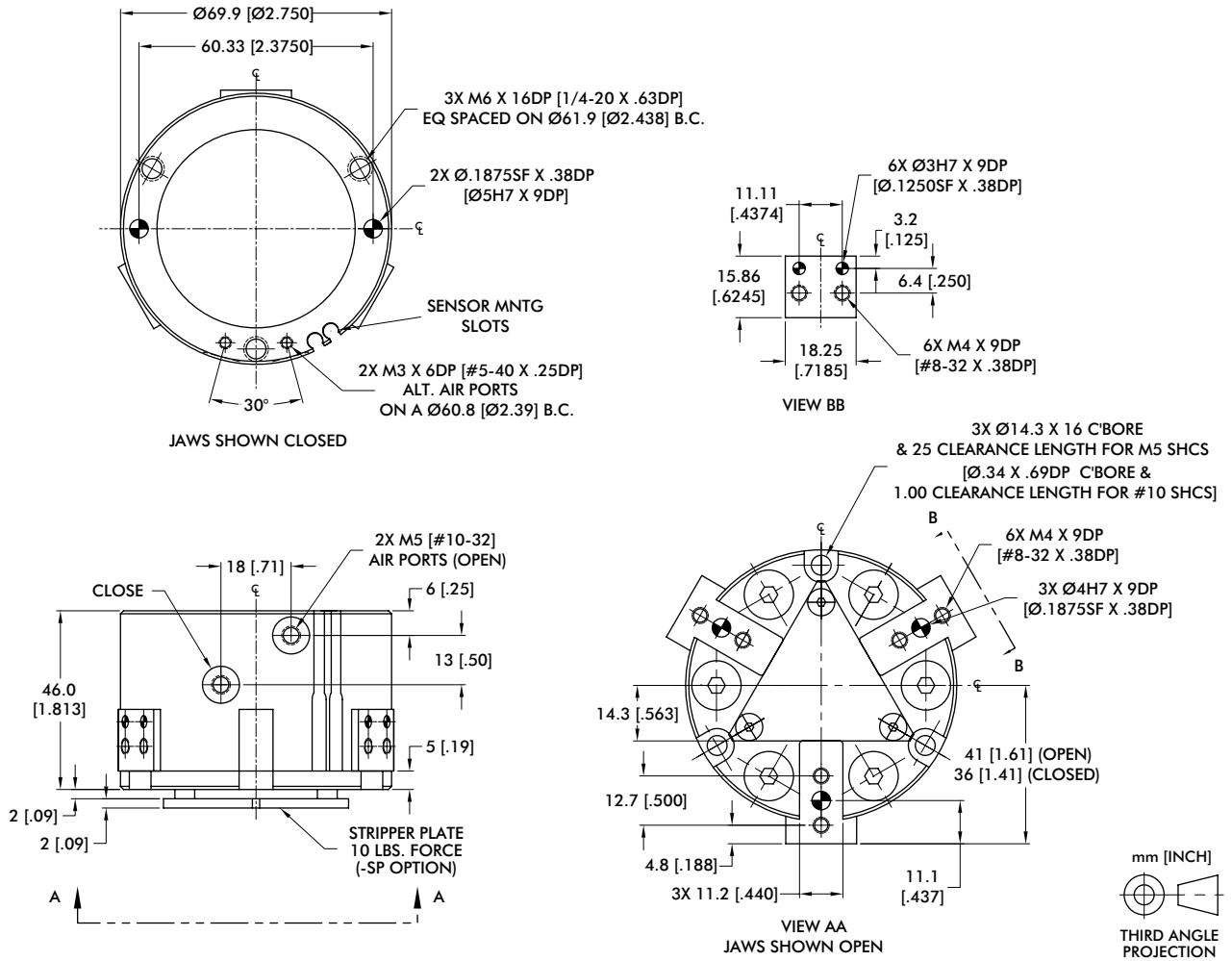

Loading Information

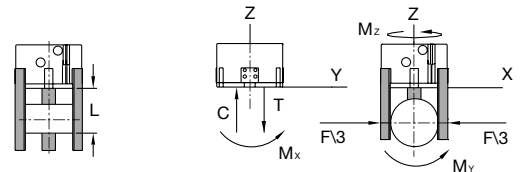
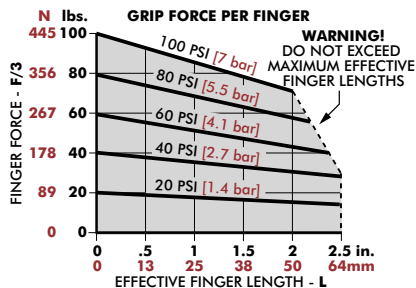

RPC-320	Static	Dynamic
Maximum Tensile T	3336 N [750 lbs]	1112 N [250 lbs]
Maximum Compressive C	3336 N [750 lbs]	1112 N [250 lbs]
Maximum Moment M_x	85 Nm [750 in-lbs]	28 Nm [255 in-lbs]
Maximum Moment M_y	85 Nm [750 in-lbs]	28 Nm [255 in-lbs]
Maximum Moment M_z	40 Nm [350 in-lbs]	11 Nm [100 in-lbs]

*Capacities are per set of jaws and are not simultaneous

RPC-331

3-Jaw Parallel Grippers | Dimensions and Technical Specifications

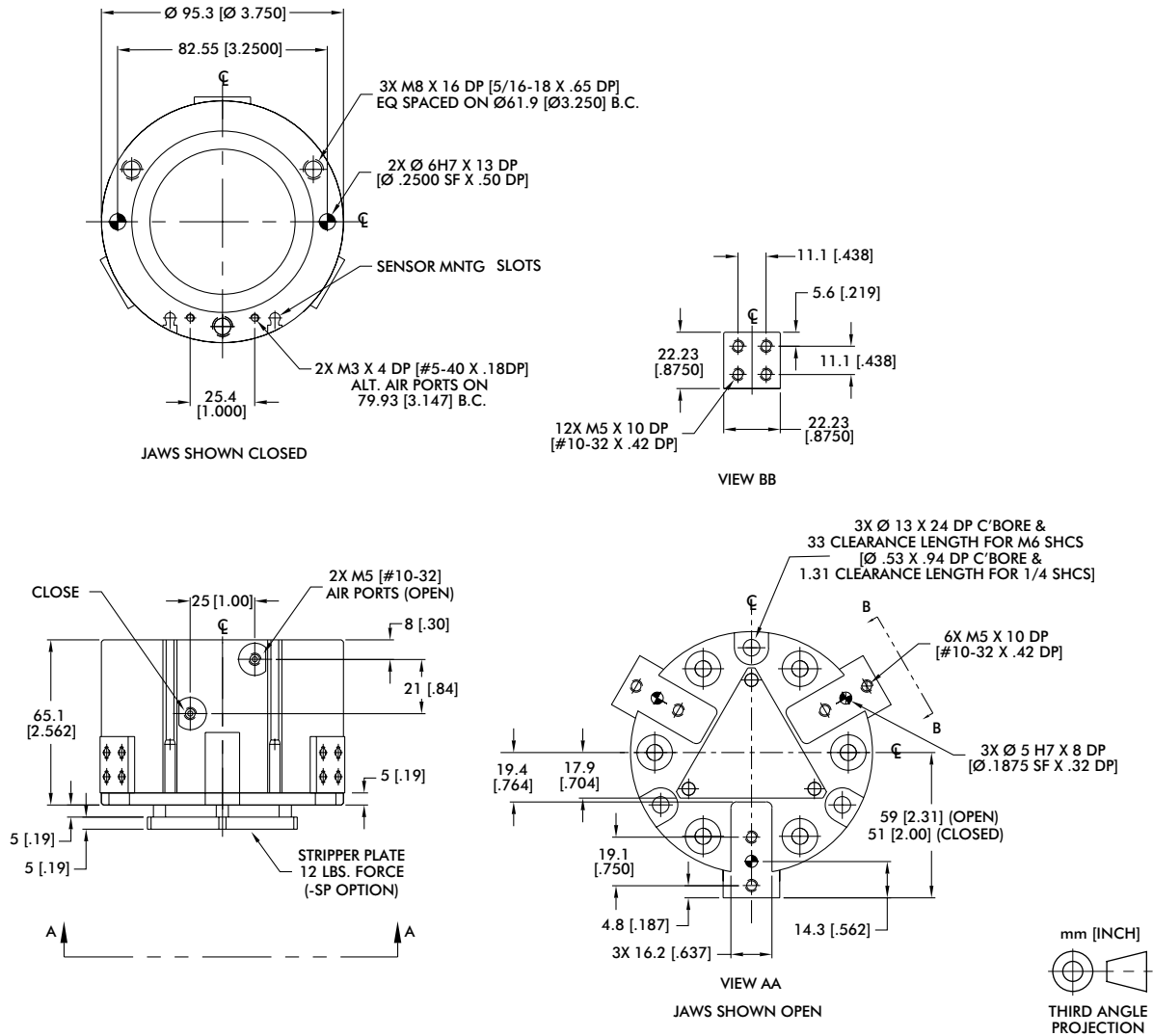

Loading Information

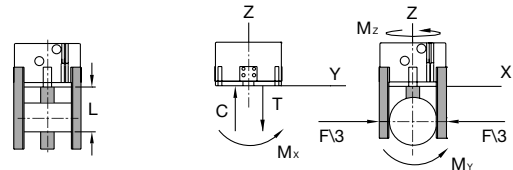
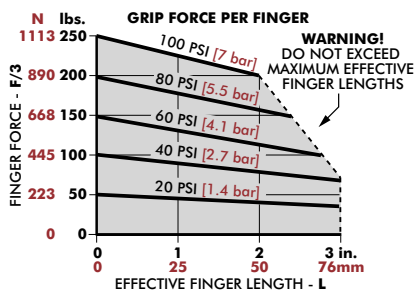

RPC-331	Static	Dynamic
Maximum Tensile T	5560 N [1250 lbs]	1779 N [400 lbs]
Maximum Compressive C	5560 N [1250 lbs]	1779 N [400 lbs]
Maximum Moment M_x	141 Nm [1250 in-lbs]	45 Nm [400 in-lbs]
Maximum Moment M_y	141 Nm [1250 in-lbs]	45 Nm [400 in-lbs]
Maximum Moment M_z	113 Nm [1000 in-lbs]	34 Nm [300 in-lbs]

*Capacities are per set of jaws and are not simultaneous

3-Jaw Parallel Grippers | Dimensions and Technical Specifications

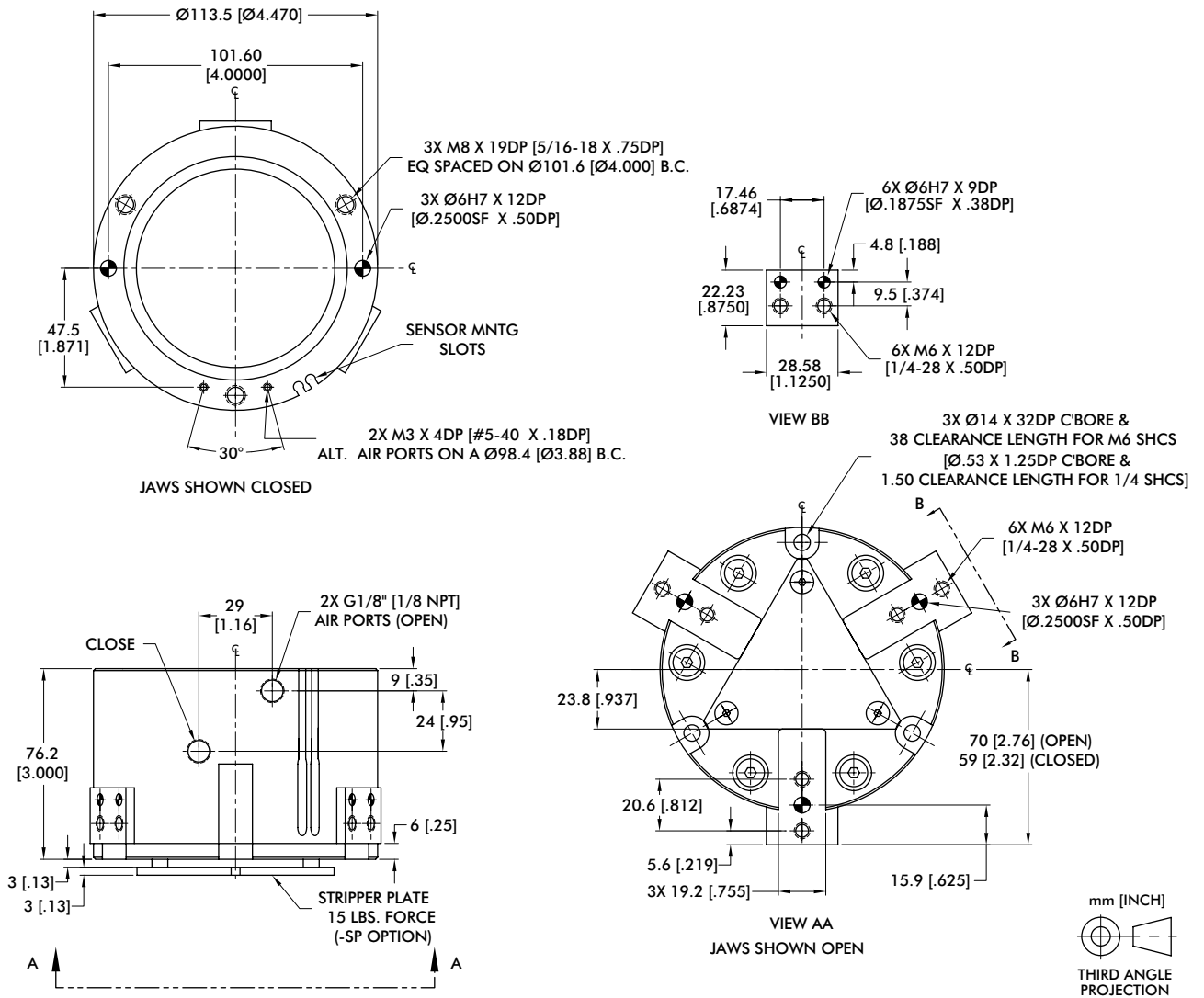

Loading Information

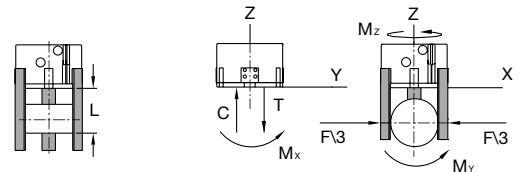
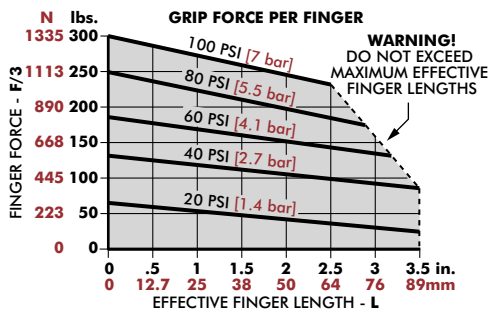

RPC-344	Static	Dynamic
Maximum Tensile T	8896 N [2000 lbs]	3336 N [750 lbs]
Maximum Compressive C	8896 N [2000 lbs]	3336 N [750 lbs]
Maximum Moment M_x	226 Nm [2000 in-lbs]	85 Nm [750 in-lbs]
Maximum Moment M_y	226 Nm [2000 in-lbs]	85 Nm [750 in-lbs]
Maximum Moment M_z	170 Nm [1500 in-lbs]	57 Nm [500 in-lbs]

*Capacities are per set of jaws and are not simultaneous

RPC-356

3-Jaw Parallel Grippers | Dimensions and Technical Specifications

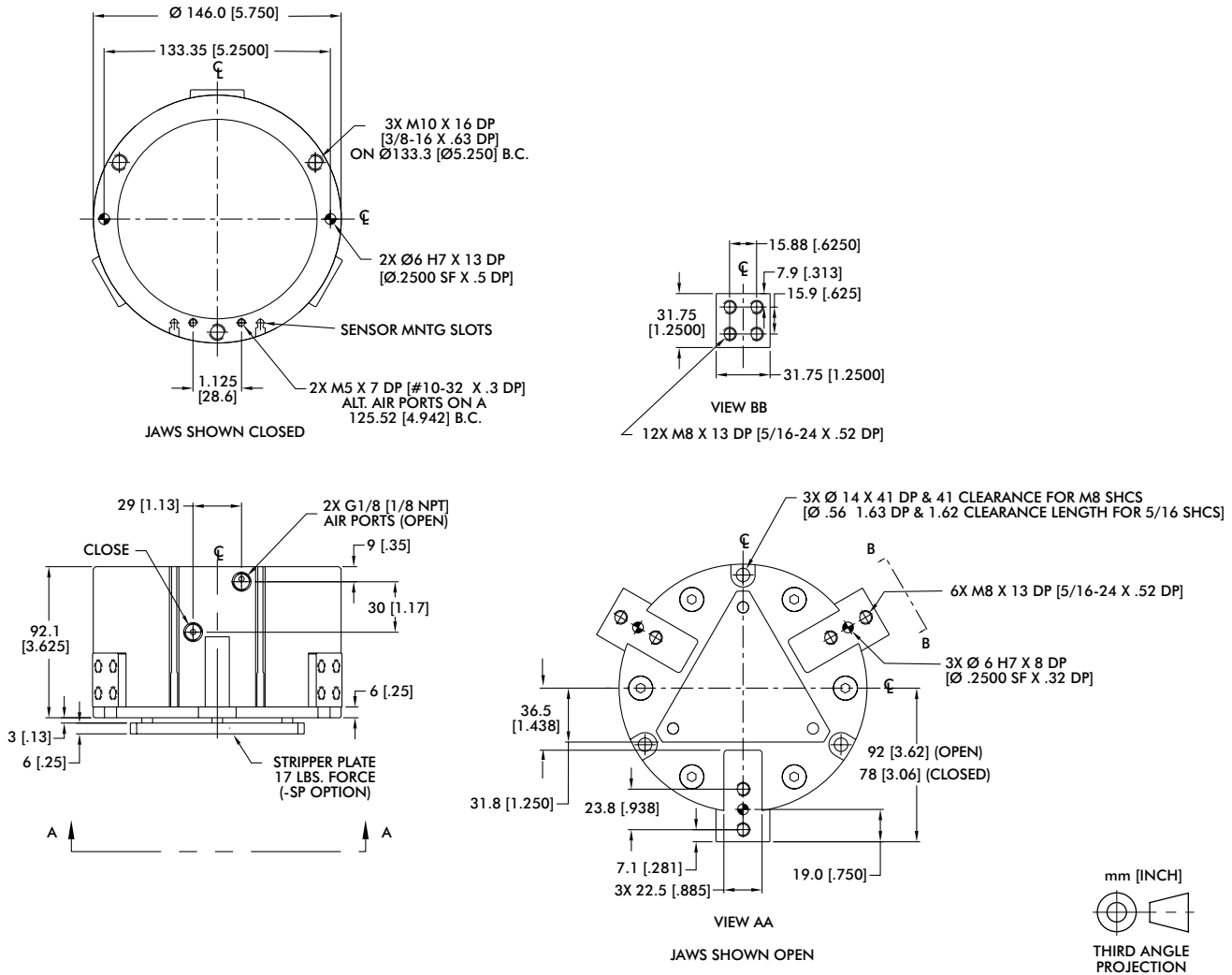

Loading Information

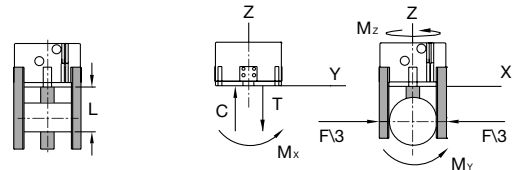
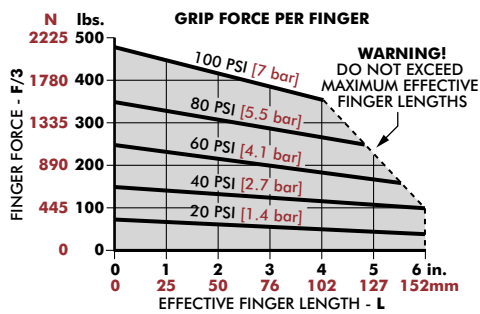

RPC-356	Static	Dynamic
Maximum Tensile T	13445 N [3000 lbs]	4448 N [1000 lbs]
Maximum Compressive C	13445 N [3000 lbs]	4448 N [1000 lbs]
Maximum Moment M_x	452 Nm [4000 in-lbs]	113 Nm [1000 in-lbs]
Maximum Moment M_y	452 Nm [4000 in-lbs]	113 Nm [1000 in-lbs]
Maximum Moment M_z	339 Nm [3000 in-lbs]	85 Nm [750 in-lbs]

*Capacities are per set of jaws and are not simultaneous

3-Jaw Parallel Grippers | Dimensions and Technical Specifications

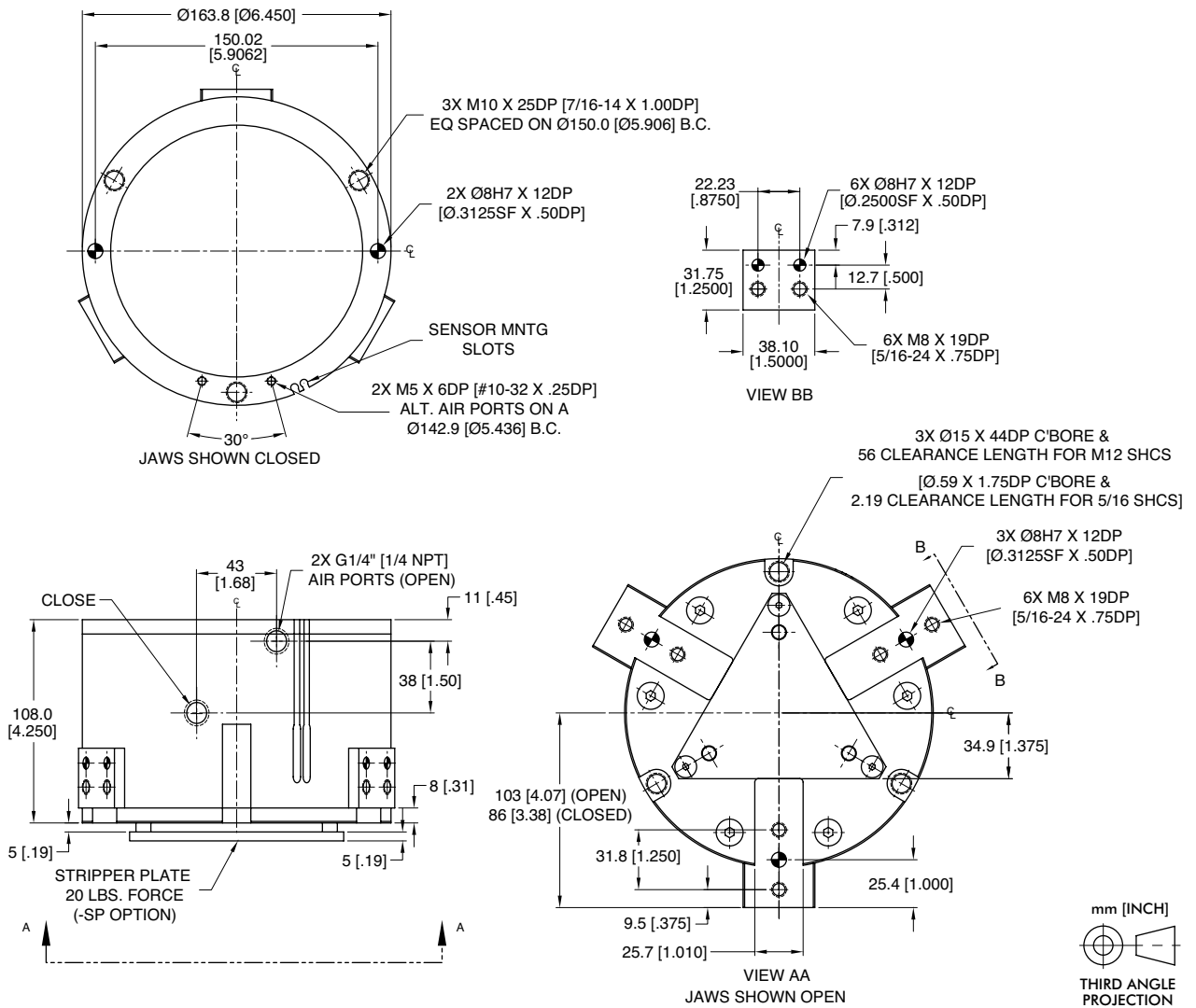

Loading Information

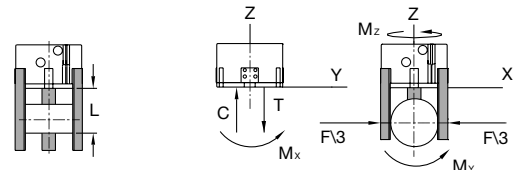
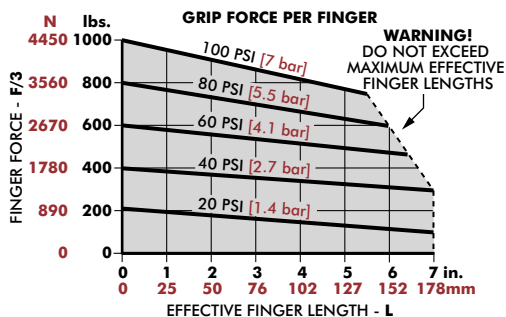

RPC-368	Static	Dynamic
Maximum Tensile T	22241 N [5000 lbs]	6672 N [1500 lbs]
Maximum Compressive C	22241 N [5000 lbs]	6672 N [1500 lbs]
Maximum Moment M_x	791 Nm [7000 in-lbs]	170 Nm [1500 in-lbs]
Maximum Moment M_y	791 Nm [7000 in-lbs]	170 Nm [1500 in-lbs]
Maximum Moment M_z	565 Nm [5000 in-lbs]	113 Nm [1000 in-lbs]

*Capacities are per set of jaws and are not simultaneous

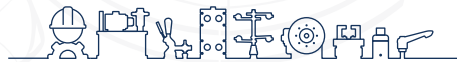

inf @ /CESEHSA.com.mx

