

REV.	DESCRIPTION	INITIATOR	DATE
01	INITIAL DRAWING	MJG	6/15/2021

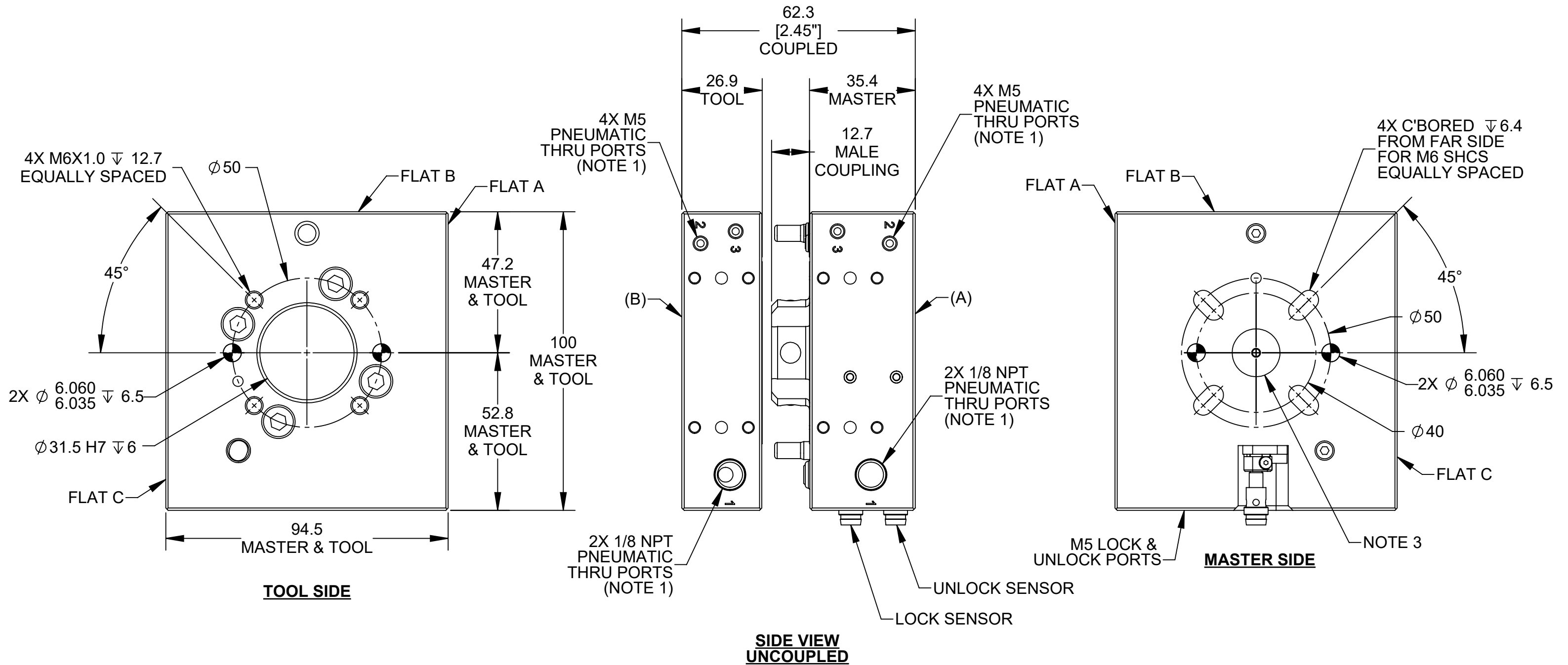

PART NUMBERS:  
 (A) MASTER: 9120-029AM-0-0-0-SX (NOTE 2)  
 (B) TOOL: 9120-029ET-0-0-0

- NOTES:
- LOCATION AND TYPE OF PNEUMATIC THRU PORTS #1-#3 ON FLAT A ARE REPEATED ON FLAT C, MIRROR IMAGE, FOR PNEUMATIC THRU PORTS #4-#6.
  - '-SX' IN MASTER PART NUMBER DENOTES SENSOR OPTIONS ARE AVAILABLE.
  - OPTIONAL MASTER SIDE MOUNTING BOSSES AVAILABLE. MOST COMMON:
    - 9120-029AM...: QC-29 MASTER WITHOUT A BOSS
    - 9120-029DM...: QC-29 MASTER WITH  $\phi$  25mm BOSS FOR ISO 9409-1-40-4-M6 MOUNTING
    - 9120-029EM...: QC-29 MASTER WITH  $\phi$  31.5mm BOSS FOR ISO 9409-1-50-4-M6 MOUNTING
  - CONTACT ATI FOR FULL PART NUMBERS AND LIST OF OPTIONS.

NOTES: UNLESS OTHERWISE SPECIFIED.

DO NOT SCALE DRAWING. ALL DIMENSIONS ARE IN MILLIMETERS.



DRAWN BY: M. GALA 5/24/21

CHECKED BY: D. FAUST 6/14/21

TITLE

QC-29 TOOL CHANGER DRAWING



3rd ANGLE PROJECTION

PROJECT # 151026-2 SHEET 1 OF 3

SCALE  
2:2.5

SIZE  
B

DRAWING NUMBER  
9630-20-029

REVISION  
01

# QC-29 MASTER ASSEMBLY

9120-029AM-0-0-0-SX

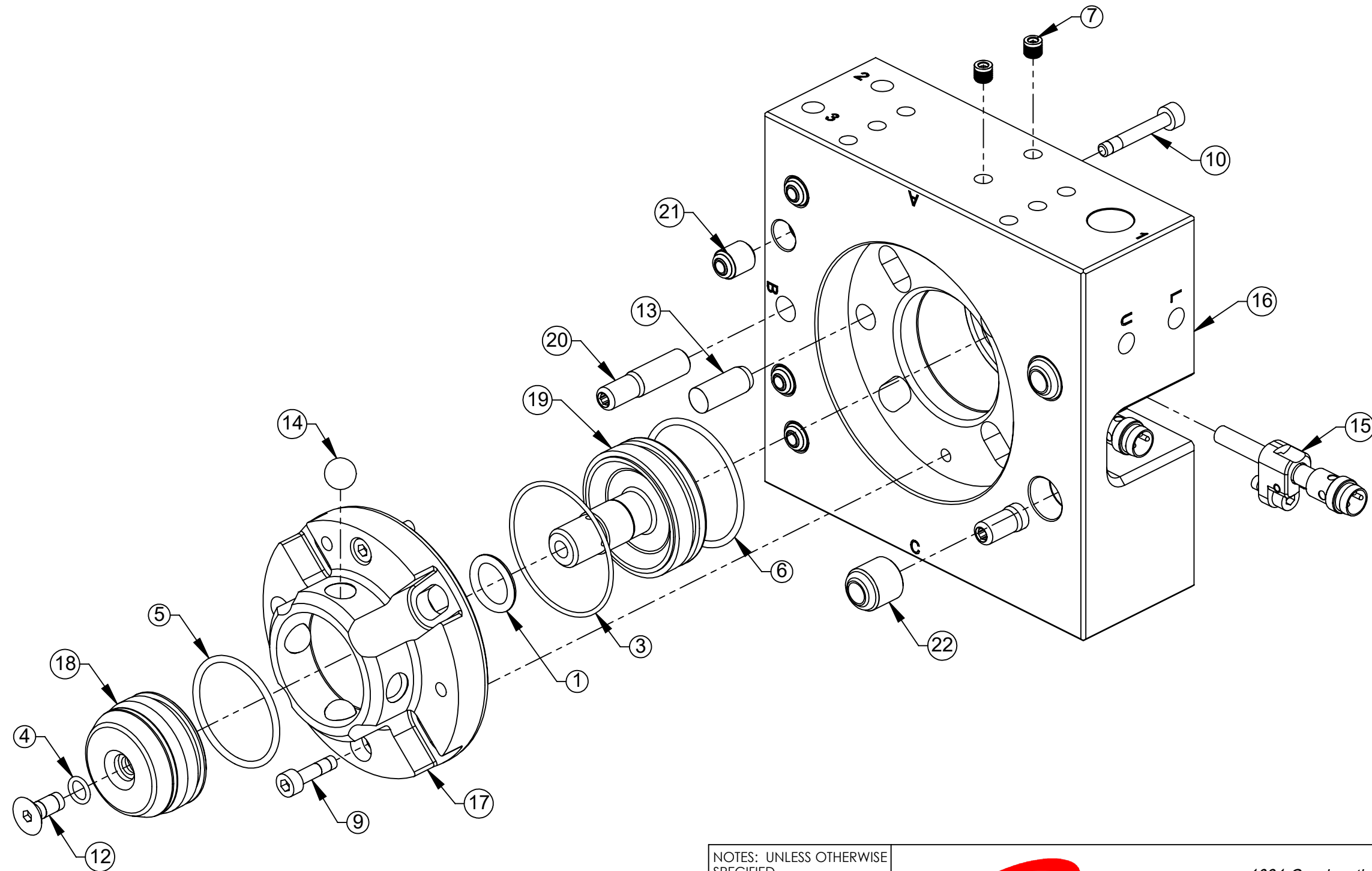

NOTES: UNLESS OTHERWISE SPECIFIED.

DO NOT SCALE DRAWING. ALL DIMENSIONS ARE IN MILLIMETERS.

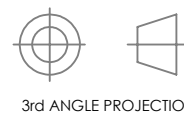

1031 Goodworth Drive, Apex, NC 27539, USA  
 Tel: +1.919.772.0115 www.ati-ia.com  
 Fax: +1.919.772.8259 ISO 9001 Registered Company

PROPERTY OF ATI INDUSTRIAL AUTOMATION, INC. NOT TO BE REPRODUCED IN ANY MANNER EXCEPT ON ORDER OR WITH PRIOR WRITTEN AUTHORIZATION OF ATI.

DRAWN BY: M. GALA 5/24/21		TITLE		
CHECKED BY: D. FAUST 6/14/21		QC-29 TOOL CHANGER DRAWING		
PROJECT # 151026-2	SHEET 2 OF 3	SCALE 1:1	SIZE B	DRAWING NUMBER 9630-20-029
				REVISION 01

# QC-29 TOOL ASSEMBLY

9120-029ET-0-0-0

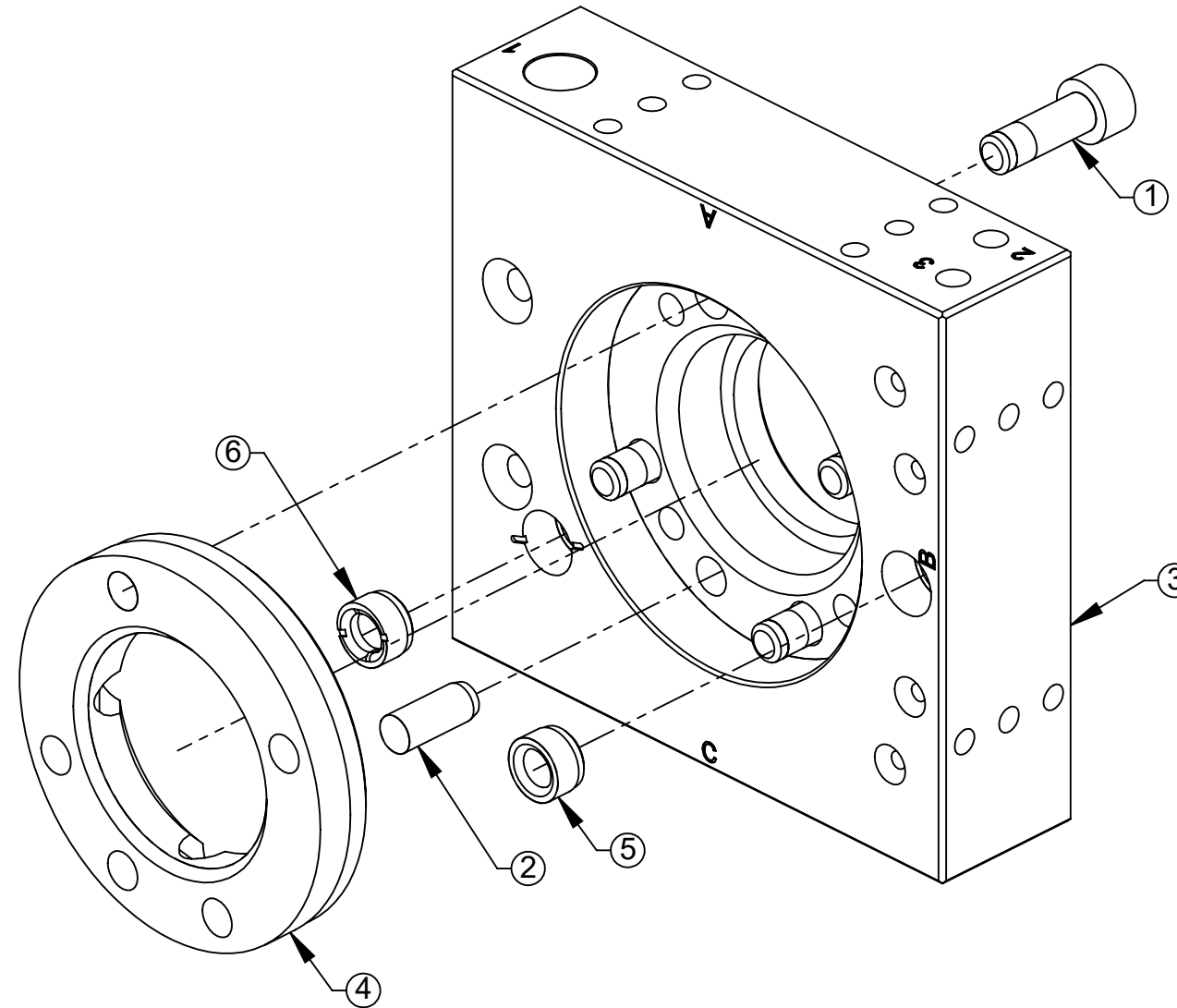

NOTES: UNLESS OTHERWISE SPECIFIED.

DO NOT SCALE DRAWING.  
ALL DIMENSIONS ARE IN MILLIMETERS.



3rd ANGLE PROJECTION



DRAWN BY: M. GALA 5/24/21

CHECKED BY: D. FAUST 6/14/21

TITLE

QC-29 TOOL CHANGER DRAWING

PROJECT # 151026-2 SHEET 3 OF 3

SCALE  
1:1

SIZE  
B

DRAWING NUMBER  
9630-20-029

REVISION  
01