

Rev.	Description	Initiator	Date
03	ECO 19842: Sheet 1: Tool Side: $\varnothing 5$ H7 Dowel depth 5 was 6.4. 28° was 30° & 24° was 20°. Coupled View: 96.3 was 97.5.	TBC	3/24/2021

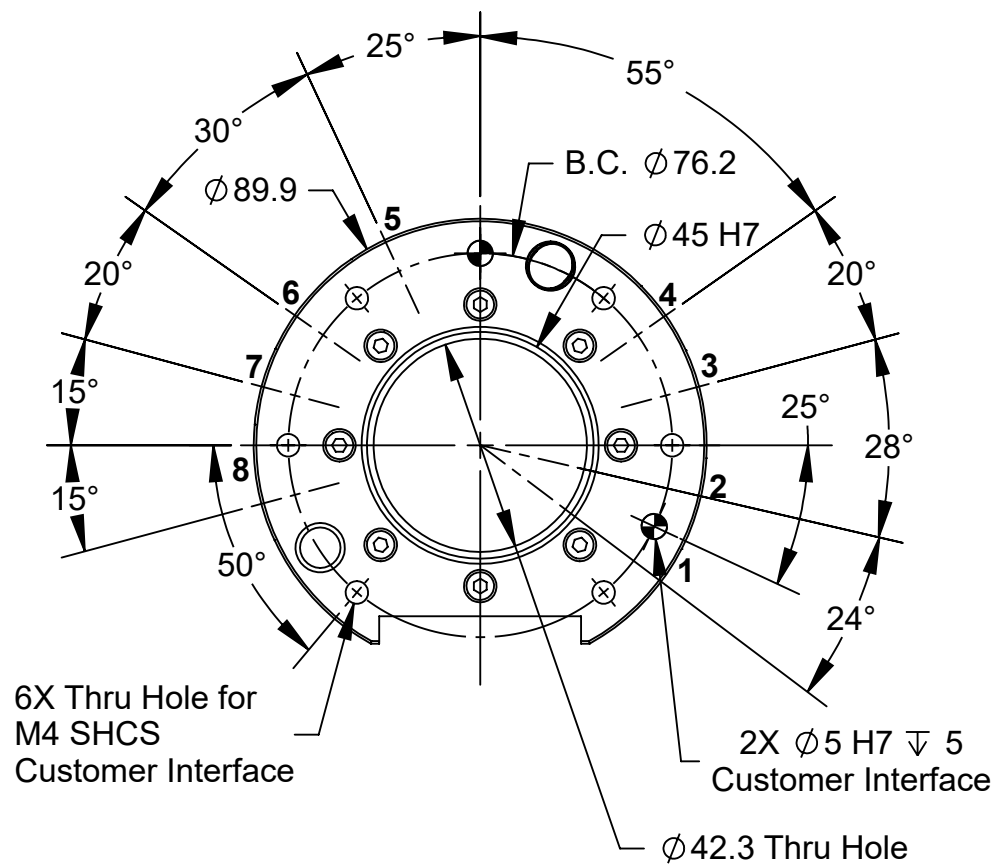

Tool Side  
(projection only)

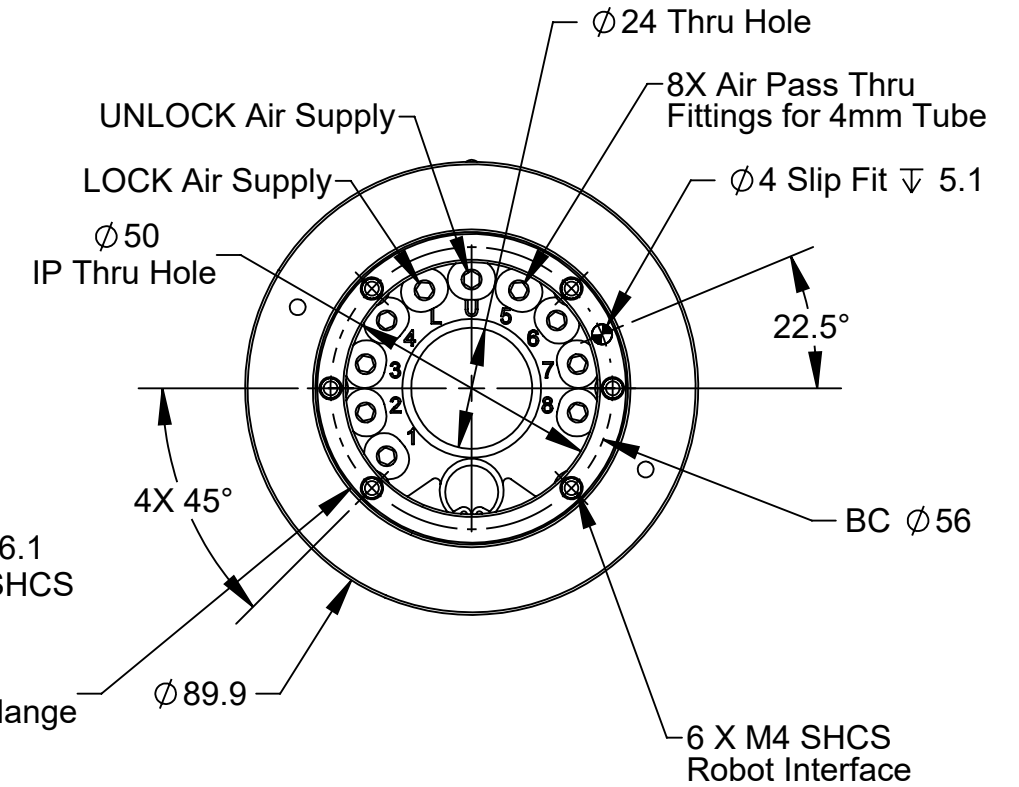
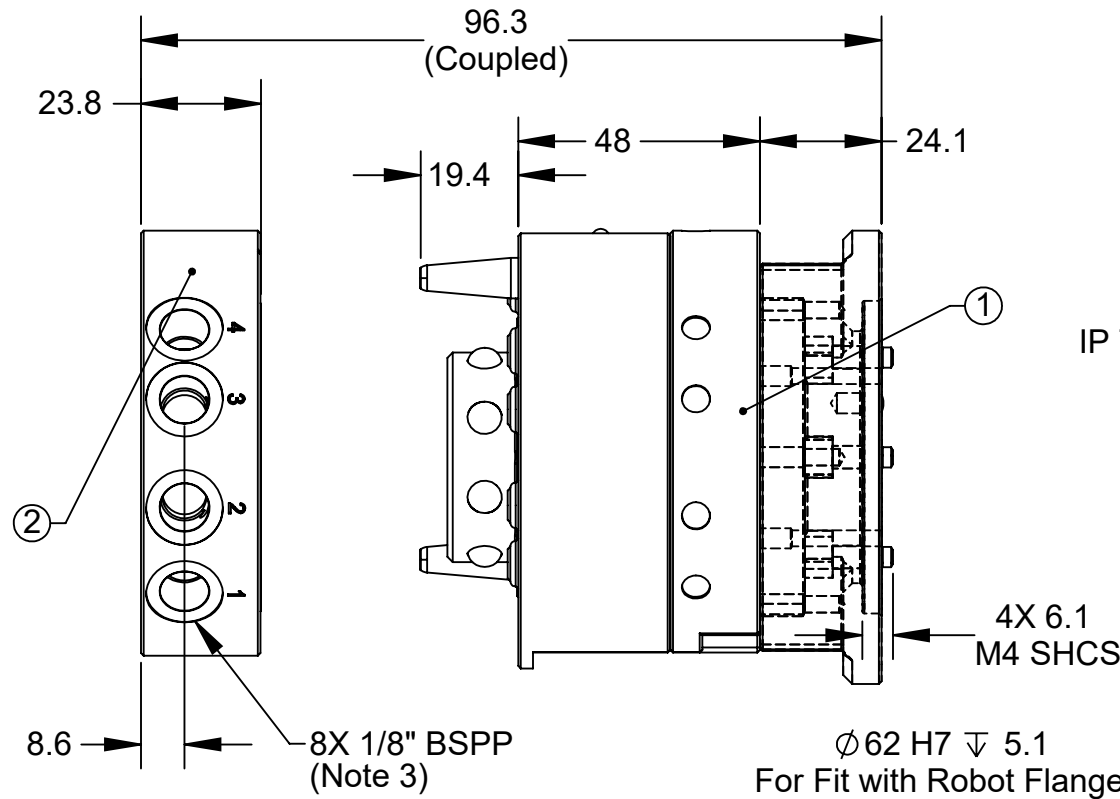

Master Side  
(projection only)

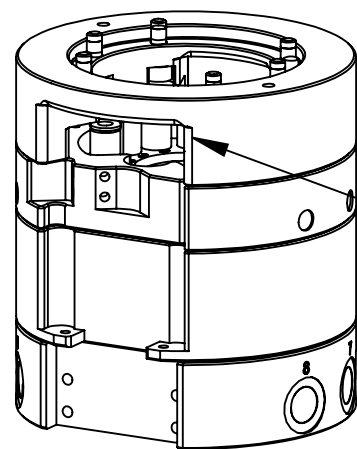

Opening for wire  
Routing Access  
Through Robot Wrist

NOTES:

1. Mounting Hardware Included on Master Side.
2. Drawing shows a master side assembly with interface plate for direct mount to Fanuc M10ia and M20ia Hollow Wrist Robots. Other versions available upon request.
3. Tool side fittings not supplied.

ITEM NO.	QTY	PART NUMBER	DESCRIPTION
1	1	9120-027HM-000-000-S0-E-6160	QC-27 Hollow Wrist Mount Master, No Sensors, Black, With 4mm Push Tube Fittings, and 6160 IP
2	1	9120-027T-000-000-E	QC-27 Tool, Black, with 8 1/8" G Pass Through Ports

NOTES: UNLESS OTHERWISE SPECIFIED.

DO NOT SCALE DRAWING. ALL DIMENSIONS ARE IN MILLIMETERS.

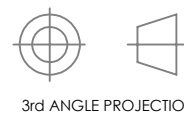

3rd ANGLE PROJECTION



DRAWN BY: L.Hines 8/9/16

CHECKED BY: TB 8/19/16

TITLE

QC-27 Base Tool Changer, BSPP, With IP 6160

SCALE  
1:1.5

SIZE  
B

DRAWING NUMBER  
9630-20-027H-E

REVISION  
03

PROJECT # SHEET 1 OF 3

**QC-27 Master Assembly**

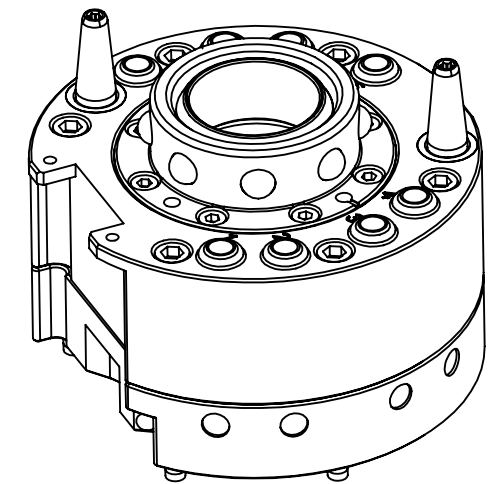
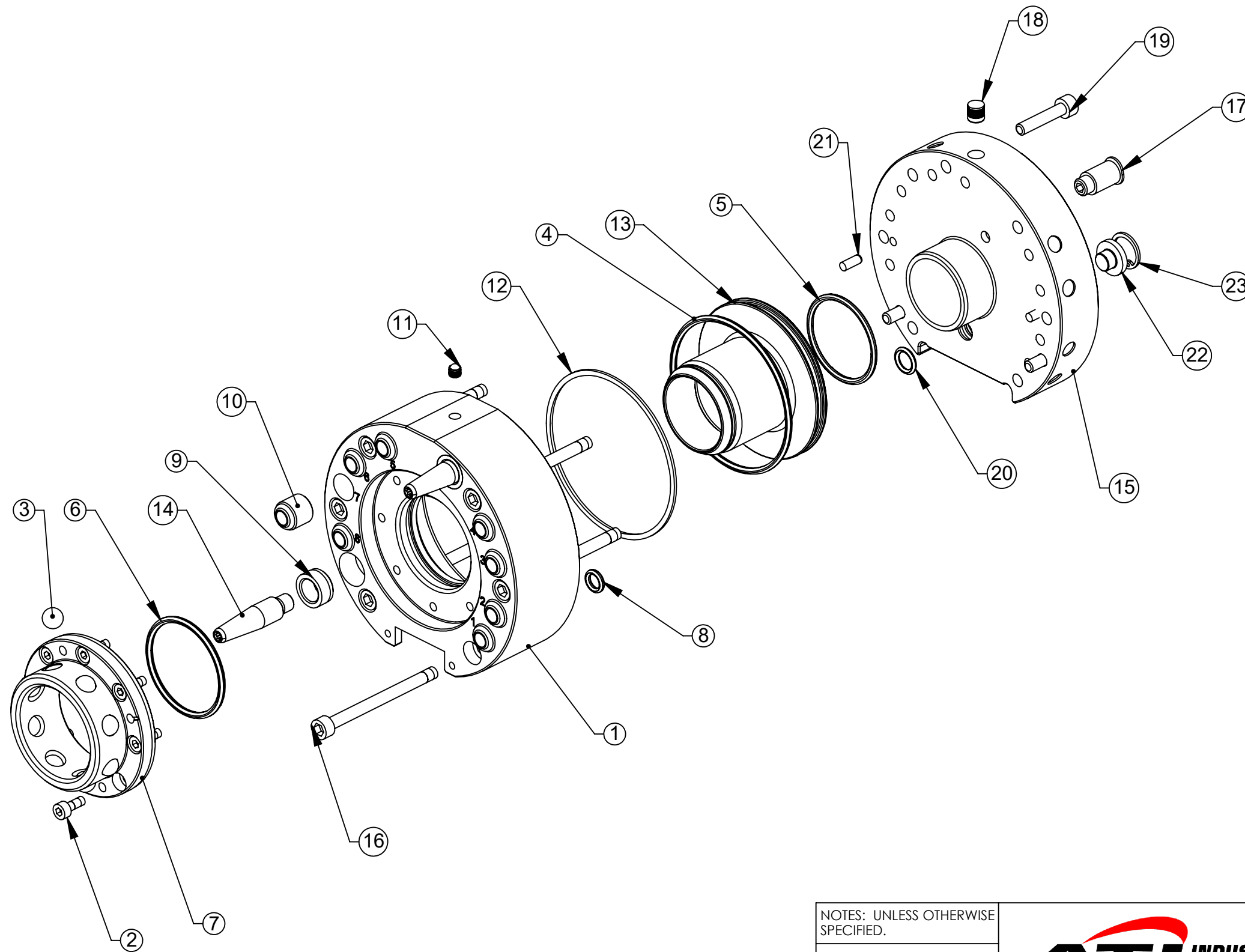

NOTES: UNLESS OTHERWISE SPECIFIED.

DO NOT SCALE DRAWING. ALL DIMENSIONS ARE IN MILLIMETERS.

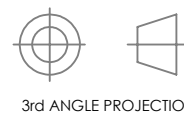

3rd ANGLE PROJECTION



1031 Goodworth Drive, Apex, NC 27539, USA  
 Tel: +1.919.772.0115 www.ati-ia.com  
 Fax: +1.919.772.8259 ISO 9001 Registered Company

PROPERTY OF ATI INDUSTRIAL AUTOMATION, INC. NOT TO BE REPRODUCED IN ANY MANNER EXCEPT ON ORDER OR WITH PRIOR WRITTEN AUTHORIZATION OF ATI.

DRAWN BY: L.Hines 8/9/16		TITLE		
CHECKED BY: TB 8/19/16		QC-27 Base Tool Changer, BSPP, With IP 6160		
PROJECT #	SHEET 2 OF 3	SCALE	SIZE	DRAWING NUMBER
		1:1.5	B	9630-20-027H-E
				REVISION
				03

# QC-27 Tool Assembly

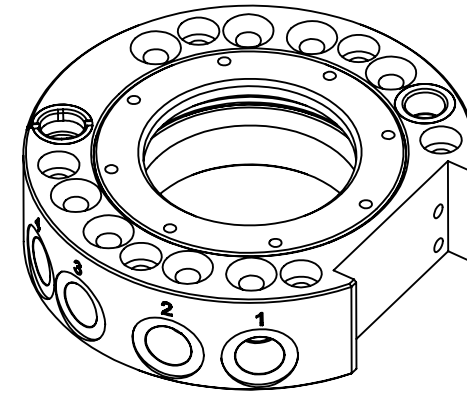
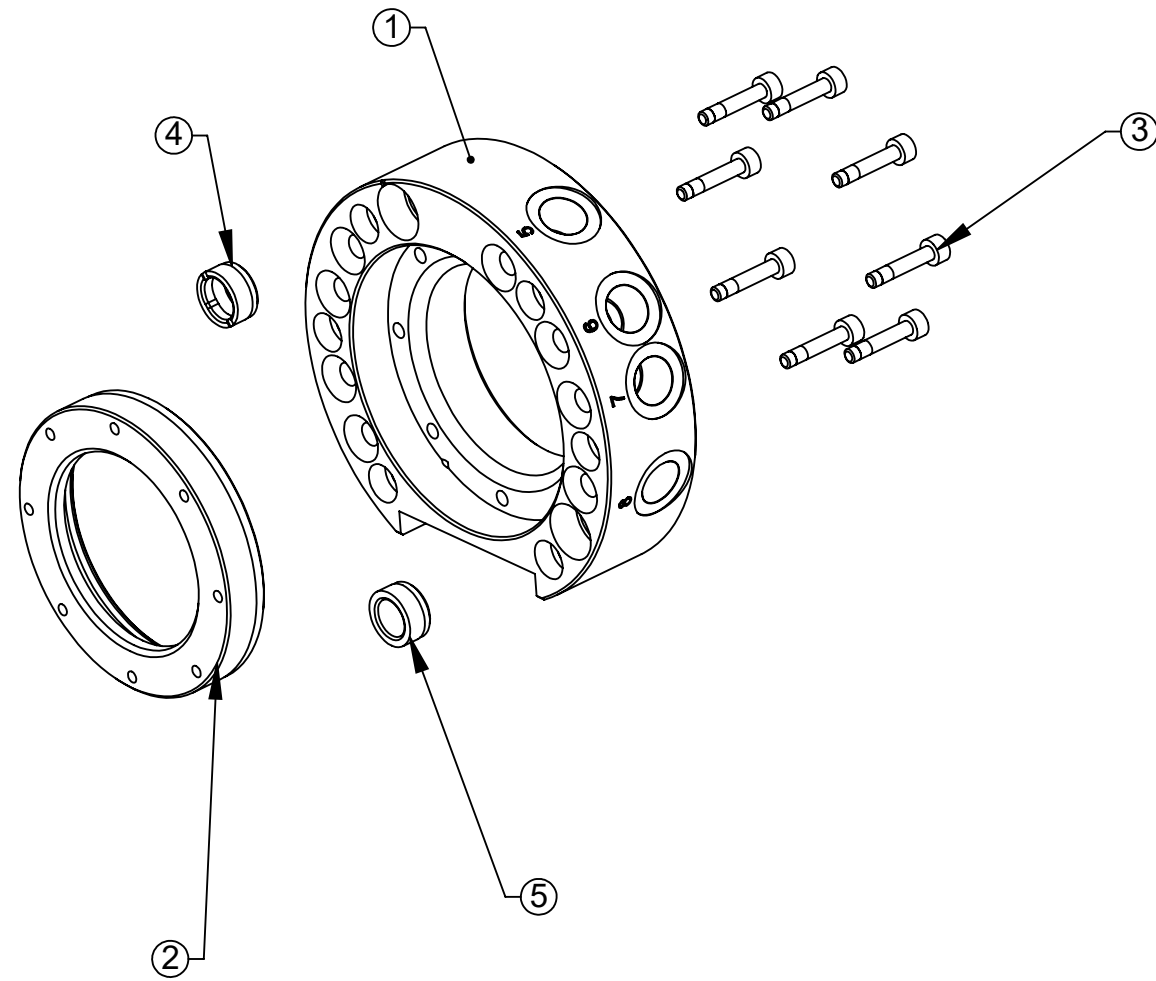

NOTES: UNLESS OTHERWISE SPECIFIED.

DO NOT SCALE DRAWING. ALL DIMENSIONS ARE IN MILLIMETERS.



3rd ANGLE PROJECTION



DRAWN BY: L.Hines 8/9/16

CHECKED BY: TB 8/19/16

PROJECT #

SHEET 3 OF 3

TITLE

QC-27 Base Tool Changer, BSPP, With IP 6160

SCALE  
1:1.5

SIZE  
B

DRAWING NUMBER  
9630-20-027H-E

REVISION  
03