

Rev.	Description	Initiator	Date
02	Eco 11974; Alignment pin was 9005-20-1200, now 9005-20-2241	LJH	4/15/2014

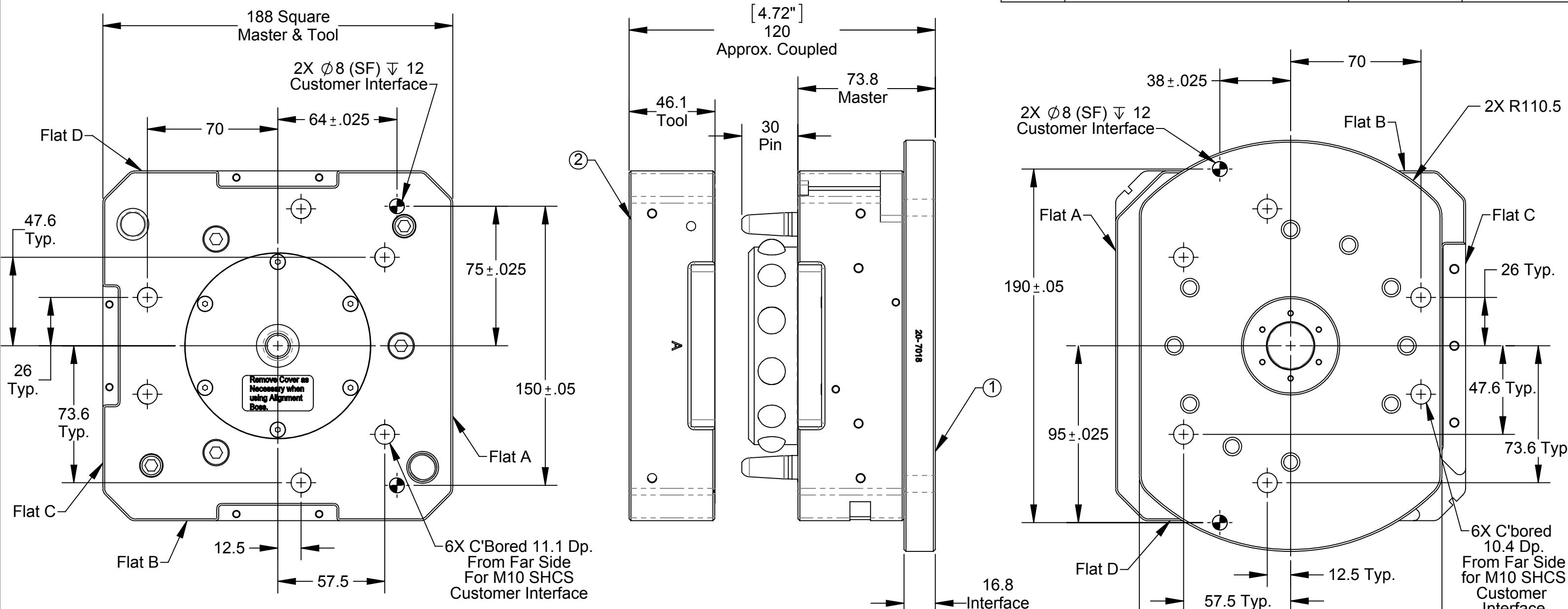

**Tool Side
(Projection Only)**

**Master Side
(Projection Only)**

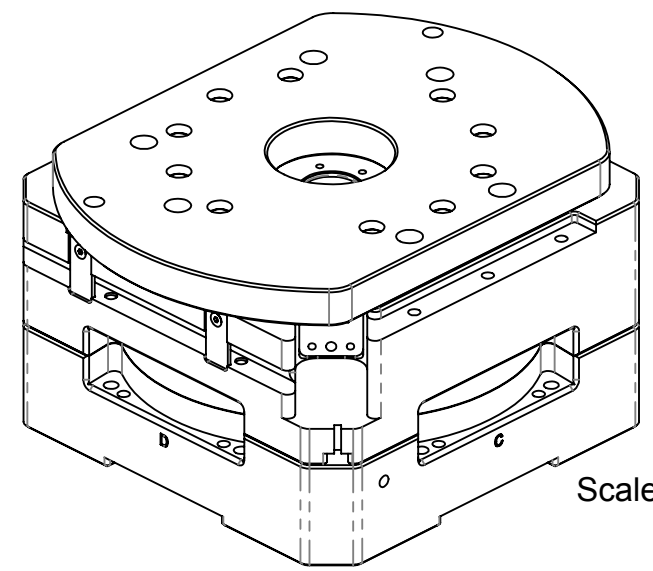

Scale 1:3

ITEM NO.	Default/QTY.	PART NUMBER	DESCRIPTION
1	1	9121-213AMX-0-0-0-0	QC-213 Master Base Assembly (Sleeveless), No Options
2	1	9121-213CT-0-0-0-0	QC-213 Base Tool Assembly, No Options

NOTES: UNLESS OTHERWISE SPECIFIED.
DO NOT SCALE DRAWING. ALL DIMENSIONS ARE IN MILLIMETERS.



PROPERTY OF ATI INDUSTRIAL AUTOMATION, INC. NOT TO BE REPRODUCED IN ANY MANNER EXCEPT ON ORDER OR WITH PRIOR WRITTEN AUTHORIZATION OF ATI.

DRAWN BY: K. Zachary 10/07/11		TITLE	
CHECKED BY: D. Norton 10/26/11		QC-213 Base Tool Changer	
SCALE	SIZE	DRAWING NUMBER	REVISION
1:2	B	9630-20-213	02
PROJECT # 110505-2 SHEET 1 OF 3			

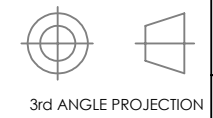

QC-213 Master Assembly

Rev.	Description	Initiator	Date
-	See Sheet1	-	-

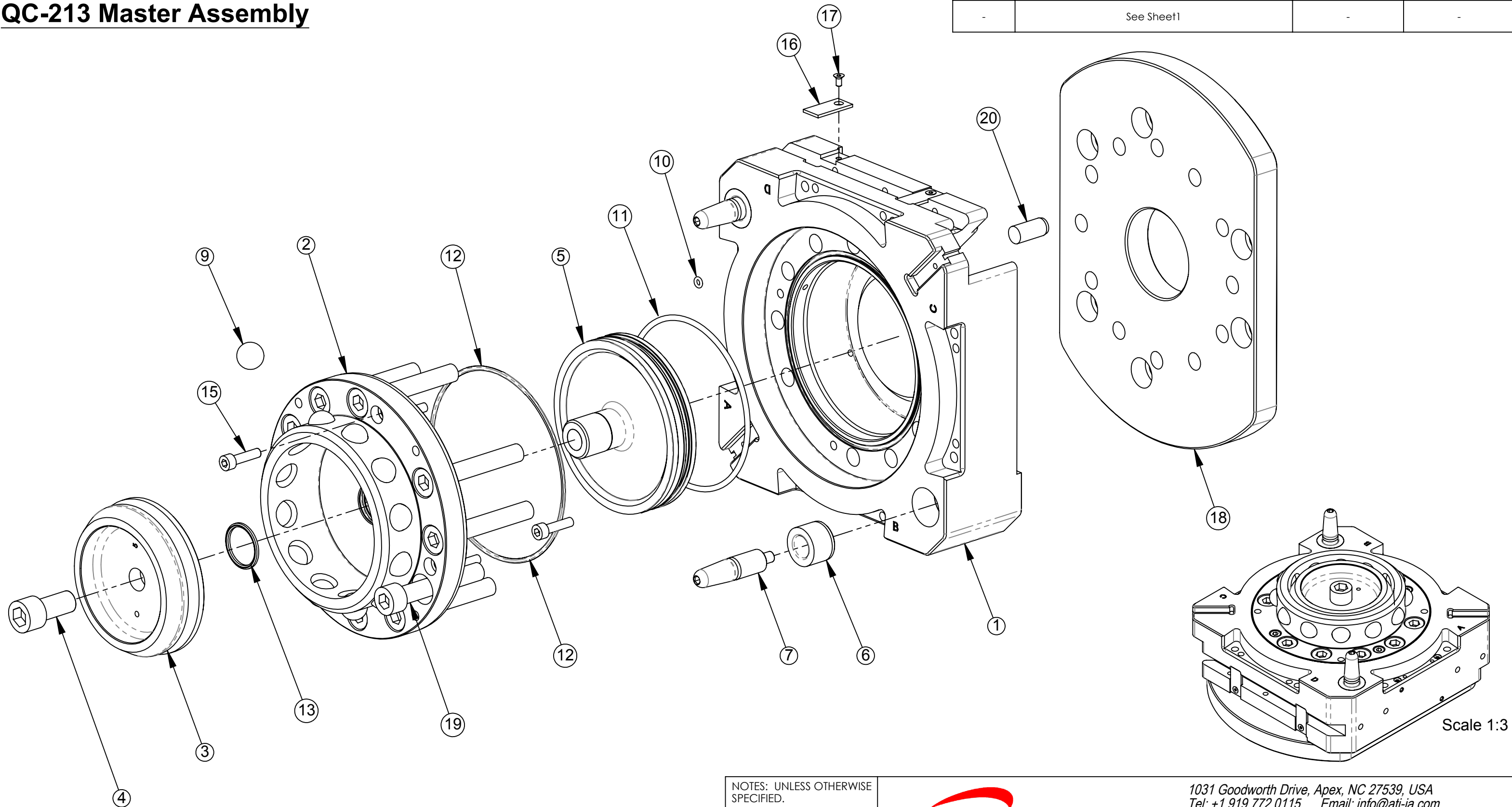

Scale 1:3

NOTES: UNLESS OTHERWISE SPECIFIED.

DO NOT SCALE DRAWING. ALL DIMENSIONS ARE IN MILLIMETERS.

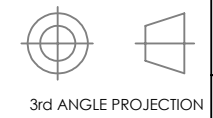

1031 Goodworth Drive, Apex, NC 27539, USA
 Tel: +1.919.772.0115 Email: info@ati-ia.com
 Fax: +1.919.772.8259 www.ati-ia.com
 ISO 9001 Registered Company

PROPERTY OF ATI INDUSTRIAL AUTOMATION, INC. NOT TO BE REPRODUCED IN ANY MANNER EXCEPT ON ORDER OR WITH PRIOR WRITTEN AUTHORIZATION OF ATI.

DRAWN BY: K. Zachary 10/07/11		TITLE	
CHECKED BY: D. Norton 10/26/11		QC-213 Base Tool Changer	
PROJECT # 110505-2	SHEET 2 OF 3	SCALE 1:2	SIZE B
		DRAWING NUMBER 9630-20-213	REVISION 02

QC-213 Tool Assembly

Rev.	Description	Initiator	Date
-	See Sheet1	-	-

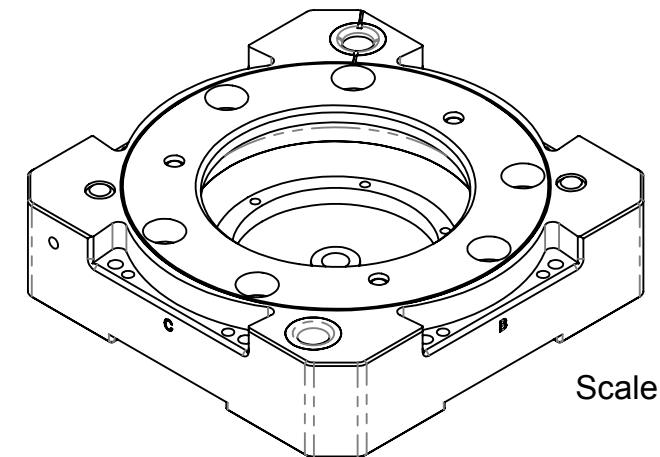
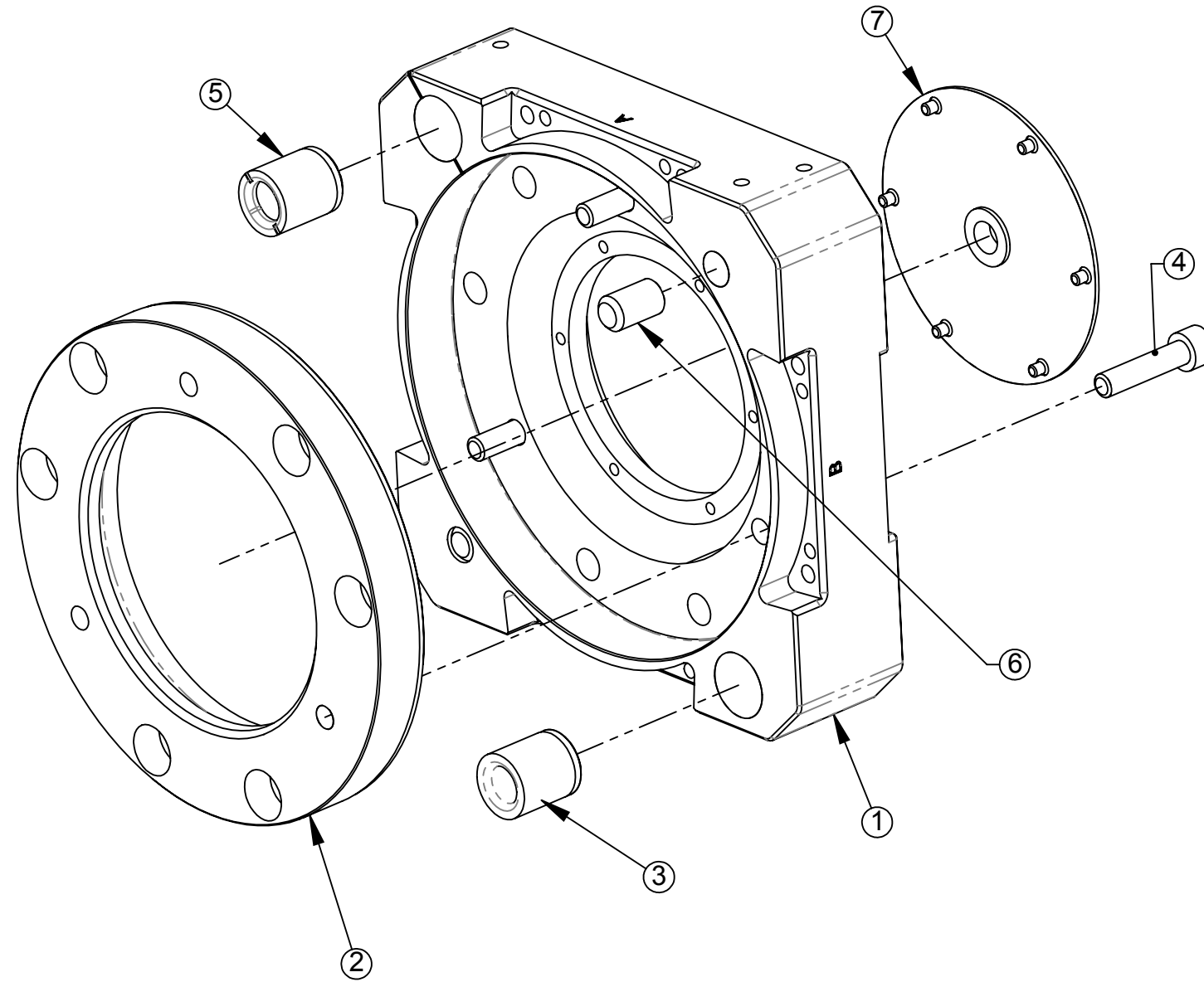

Scale 1:3

NOTES: UNLESS OTHERWISE SPECIFIED.

DO NOT SCALE DRAWING. ALL DIMENSIONS ARE IN MILLIMETERS.



3rd ANGLE PROJECTION



PROPERTY OF ATI INDUSTRIAL AUTOMATION, INC. NOT TO BE REPRODUCED IN ANY MANNER EXCEPT ON ORDER OR WITH PRIOR WRITTEN AUTHORIZATION OF ATI.

DRAWN BY: K. Zachary 10/07/11

CHECKED BY: D. Norton 10/26/11

TITLE
QC-213 Base Tool Changer

PROJECT # 110505-2 SHEET 3 OF 3

SCALE	SIZE	DRAWING NUMBER	REVISION
1:2	B	9630-20-213	02