

Rev.	Description	Initiator	Date
03	Eco 14784; On lower level assembly, changed female connector 1510-2313028-12 to 1510-1313031-12, updated Turck p/n Sheet 2.	LJH	8/19/16

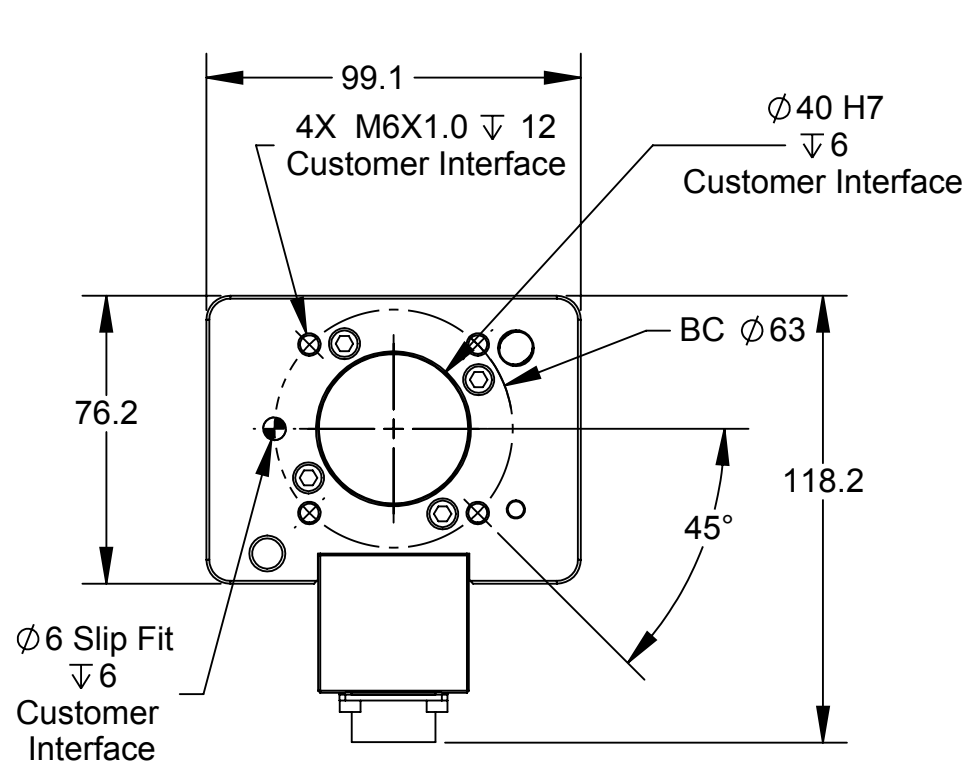

TOOL SIDE MOUNTING FACE

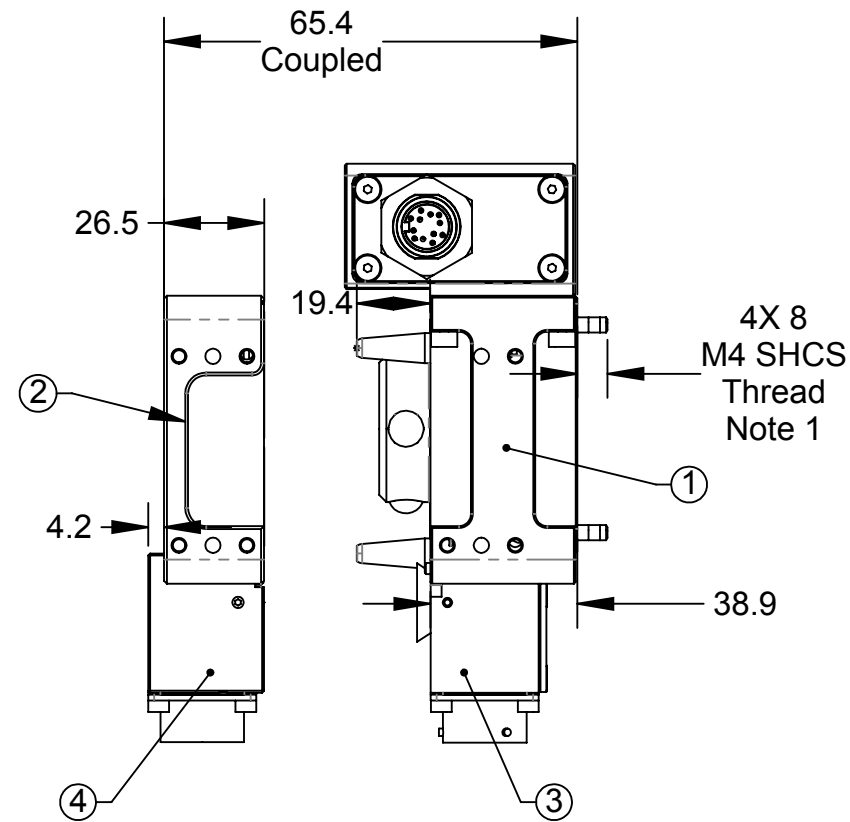

SIDE VIEW UNCOUPLED

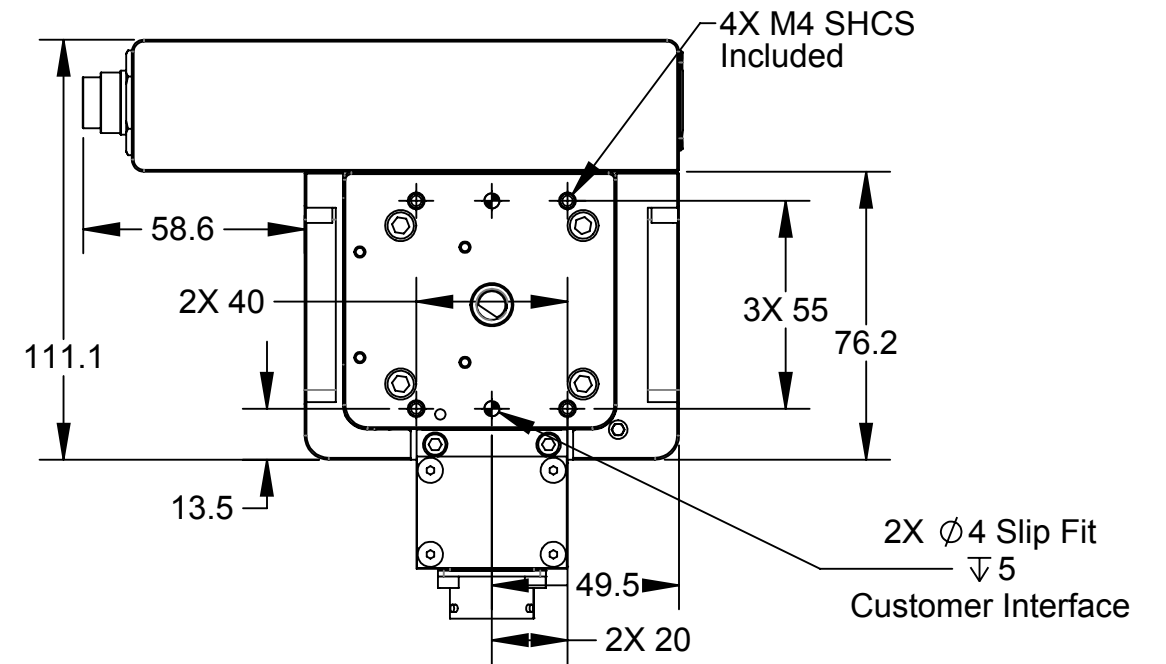

MASTER SIDE MOUNTING FACE

Notes:

1. Available screw engagement. Dowel pins not included.
2. Lock, Unlock, and RTL sensing included. Features 3 wire, PNP DC Proximity sensors. RTL is pass through.
3. ATI Motor Controller is integrated into motor housing.
4. Motor is 24V DC Brushless Servo with hall sensor feedback.
5. Additional Motor options available.
6. Recommended max X-Y misalignment prior to coupling: +/-1mm at 20mm separation distance.
7. Recommended max separation distance prior to issuing latch command: 1.0mm
8. Estimated Mass with motor module shown (electrical module not included):
Master Side = 1.47kg Tool Side = 0.4kg

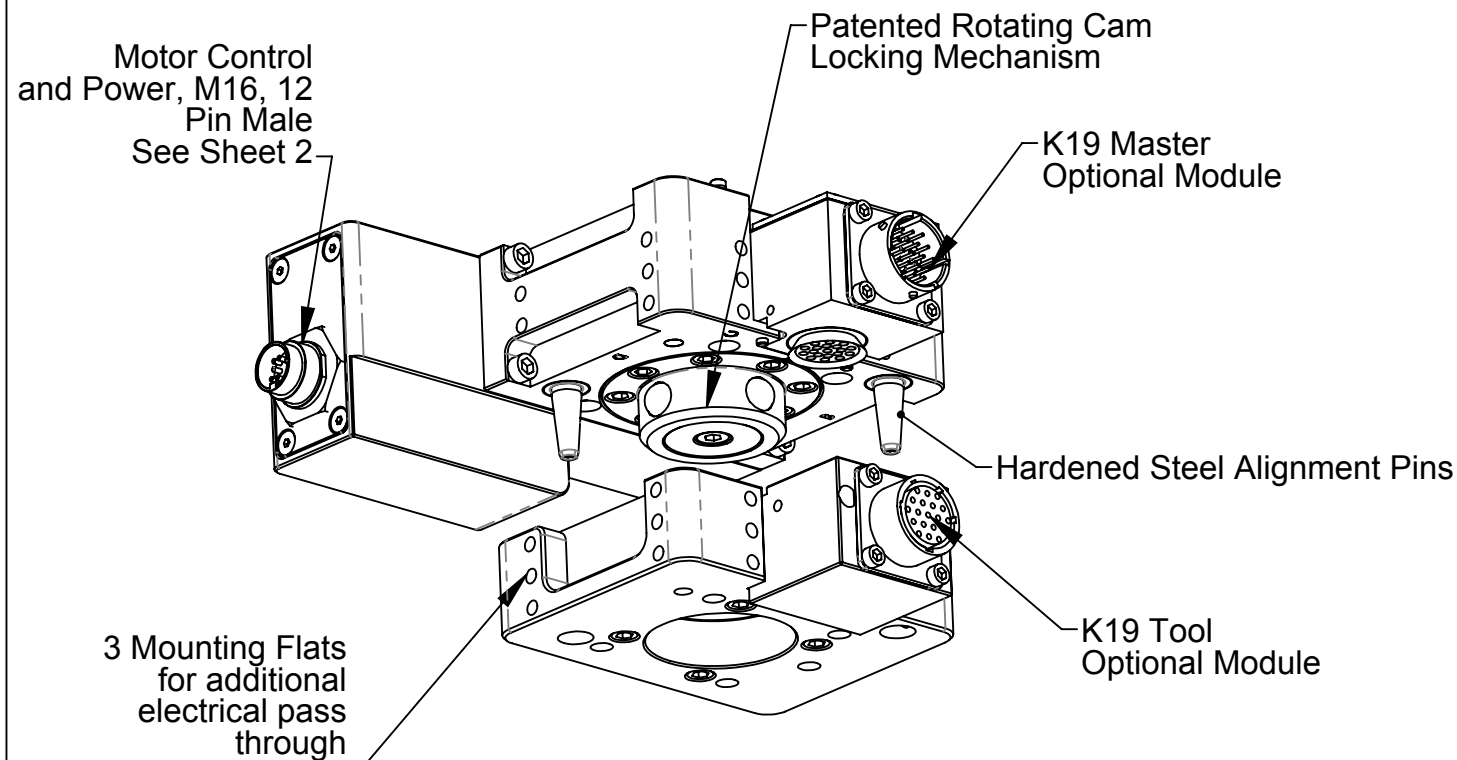

ITEM NO.	QTY	PART NUMBER	DESCRIPTION
1	1	9120-018M-2387-0-0-0-SG2	QC-18 Master Assy, w/ 24VDC Motor Module 2387, Integrated Controls, PNP DC Sensors, M5 RTL
2	1	9120-018T-0-0-0-0	QC-18 Tool Base Assembly
3	1	9120-K19-M	9120-K19-M Master Module
4	1	9120-K19-T	9120-K19-T Tool Module

NOTES: UNLESS OTHERWISE SPECIFIED.

DO NOT SCALE DRAWING. ALL DIMENSIONS ARE IN MILLIMETERS.



3rd ANGLE PROJECTION



PROPERTY OF ATI INDUSTRIAL AUTOMATION, INC. NOT TO BE REPRODUCED IN ANY MANNER EXCEPT ON ORDER OR WITH PRIOR WRITTEN AUTHORIZATION OF ATI.

DRAWN BY: Dan Norton 6/2/15		TITLE	
CHECKED BY: B. Kendrick 6/15/16		QC-18 With 2387 Motor Module, K19	
SCALE	SIZE	DRAWING NUMBER	REVISION
1:2	B	9230-20-7830	03

PROJECT # 120424-3 SHEET 1 OF 2

QC-18 2387 CONTROLLER DETAIL

Rev.	Description	Initiator	Date
-	See Sheet1	-	-

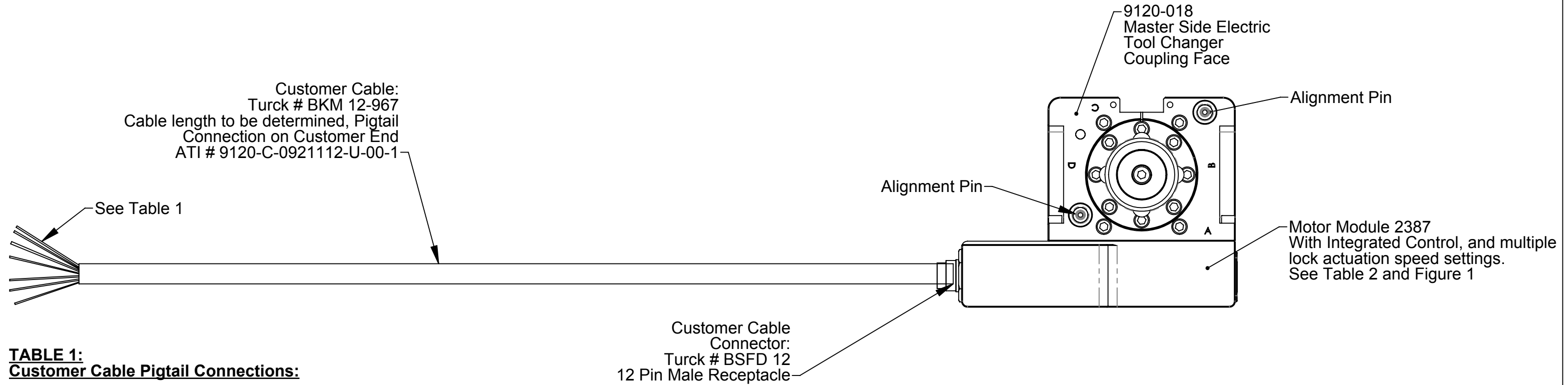

TABLE 1:
Customer Cable Pigtail Connections:

Signal Name	Wire Color
Latch	Black
Unlatch	Orange
RTL	Blue
US1	Violet
US2	Red
US1_GND	Yellow
US2_GND	Green
Locked	White
Unlocked	Tan
No Connect	Brown
No Connect	Gray
No Connect	Pink

TABLE 2:
Lock Actuation Speed DIP Switch Settings:
Lock Speed Algorithm selection is based on DIP switch settings. Default DIP setting is: SW1 channel 1 off, channel 2 off. Unlock speed is always 1 second.

Lock Algorithm	DIP SW 1	DIP SW 2	Speed (sec)
Regular speed	off	off	1
Medium1 speed	off	on	30
Medium2 speed	on	off	200
Slow Speed	on	on	360

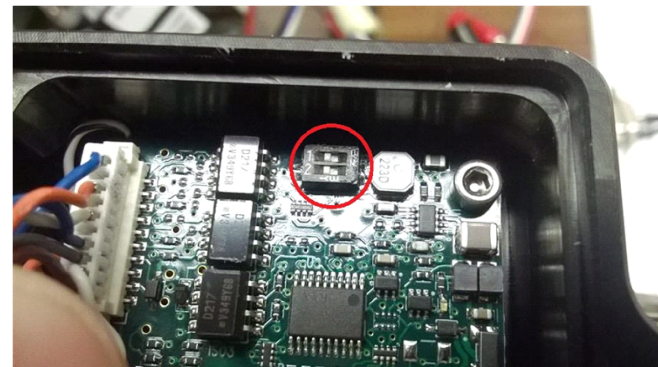
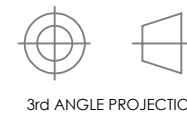

Figure 1:
Lock Actuation Speed DIP Switch Location

NOTES: UNLESS OTHERWISE SPECIFIED.

DO NOT SCALE DRAWING. ALL DIMENSIONS ARE IN MILLIMETERS.



3rd ANGLE PROJECTION



PROPERTY OF ATI INDUSTRIAL AUTOMATION, INC. NOT TO BE REPRODUCED IN ANY MANNER EXCEPT ON ORDER OR WITH PRIOR WRITTEN AUTHORIZATION OF ATI.

DRAWN BY: Dan Norton 6/2/15		TITLE	
CHECKED BY: B. Kendrick 6/15/16		QC-18 With 2387 Motor Module, K19	
PROJECT #	120424-3	SHEET	OF 2
SCALE	1:2	SIZE	B
DRAWING NUMBER		REVISION	
9230-20-7830		03	