

# 812 Series



## Pneumatic Toggle Clamps | Product Overview

### Features:

- Smallest of the pneumatic hold down series
- Pneumatic version of Model 201-U

### Applications:

- Assembly
- Welding

### Also Available:

See page MC-ACC-1  
for spindle accessories

See page MC-PSC-40  
for sensing options

High temperature version available  
upon request as Model 812-U-HT

### 812-U



## Technical Information | Holding Capacities

Model	Maximum Holding Capacity		Maximum Exerting Force @ 5bar [72PSI]		Weight	Bore Size	Air Consumption† dm <sup>3</sup> [ft <sup>3</sup> ]	Port Size	Accessories (Supplied)	
	Inner	Outer	Inner	Outer					Spindle Accessory	Flanged Washers
812-U	[100 lbf] 440 N	[55 lbf] 245 N	[136 lbf] 613 N	[92 lbf] 413 N	[0.46lb] 0,21kg	[0.75] 19,1	[0.003] 0,09	M5	305208-M	102111

†Per double stroke at 5bar [72PSI]

Max. Operating Temp: -23°C to 74°C [-10°F to 165°F]

Optional Sensors: 810156, 810158

Replacement Clamp Assembly: 812-U-LC

Replacement Cylinder Assembly: 812CYL

In no case should the inlet pressure be high enough to create an exerting force that exceeds the clamp's holding capacity. See Technical Appendix Section for details.

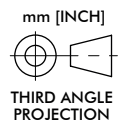
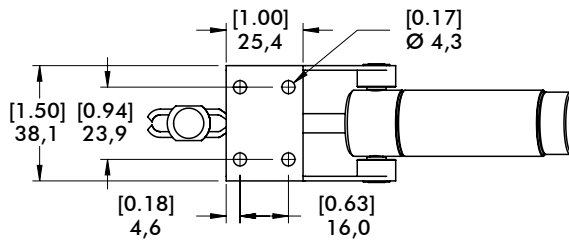
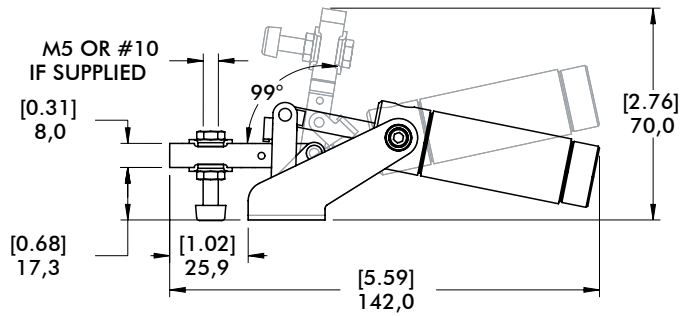
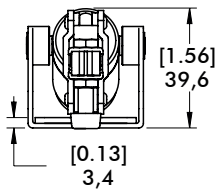
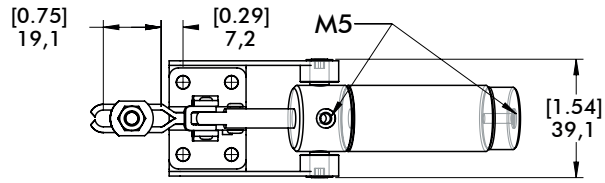
**812-U**

**Note:**

Model 812-U requires either 810156 or 810158 sensors. Two (2) sensors are required if detecting both open and closed positions. These sensors use 810156-1 (included with sensors) band clamp to mount the sensor to the cylinder wall.

