

Features:

- Threaded body may be mounted in a tapped hole or a clearance hole with optional mounting flange. 8215/8216 may be mounted with the upper flange.
- Sensor ready for use with round style sensors
- Clamp arm and spindle included

Applications:

- Assembly
- Welding
- Light machining

Also Available:

- See page MC-PSC-31 for clamping arms
- See page MC-PSC-31 for mounting flanges
- See page MC-PSC-40 for sensing options



Technical Information

Model	Swing Direction	Total Stroke [in] mm	Stroke During Rotation [in] mm	Vertical Clamp Stroke [in] mm	Clamping Force [lbf.] N†	Bore Size [in] mm	Air Consumption‡ [ft³] dm³	Weight [lbs] kg	Replacement Seal Kit
8015	RH	[0.85]	[0.47]	[0.38]	[18]	[0.75]	[0.002]	[1.0]	801560
8016	LH	21,5	11,8	9,7	80	19,1	0,06	0,45	
8215	RH	[1.25]	[0.75]	[0.50]	[67]	[1.50]	[0.015]	[2.2]	821560
8216	LH				300	38,1	0,41	1	
8415	RH	31,8	19,1	12,7	[55]	[1.19]	[0.009]	[1.5]	841560
8416	LH				245	30,2	0,25	0,68	

† with standard clamping arm at 5 bar [72psi]. ‡ per double stroke at 5 bar [72psi]

Operating Pressure Range: 3 bar [45 psig] to 9 bar [130 psig]

Maximum Operating Temperature: 60°C [140°F]

Note:

To order without clamping arm add **-LA** to the end of the model. Ex. 8215-**LA**



8000, 8200, 8400 SERIES

Pneumatic Swing Clamps | Dimensions

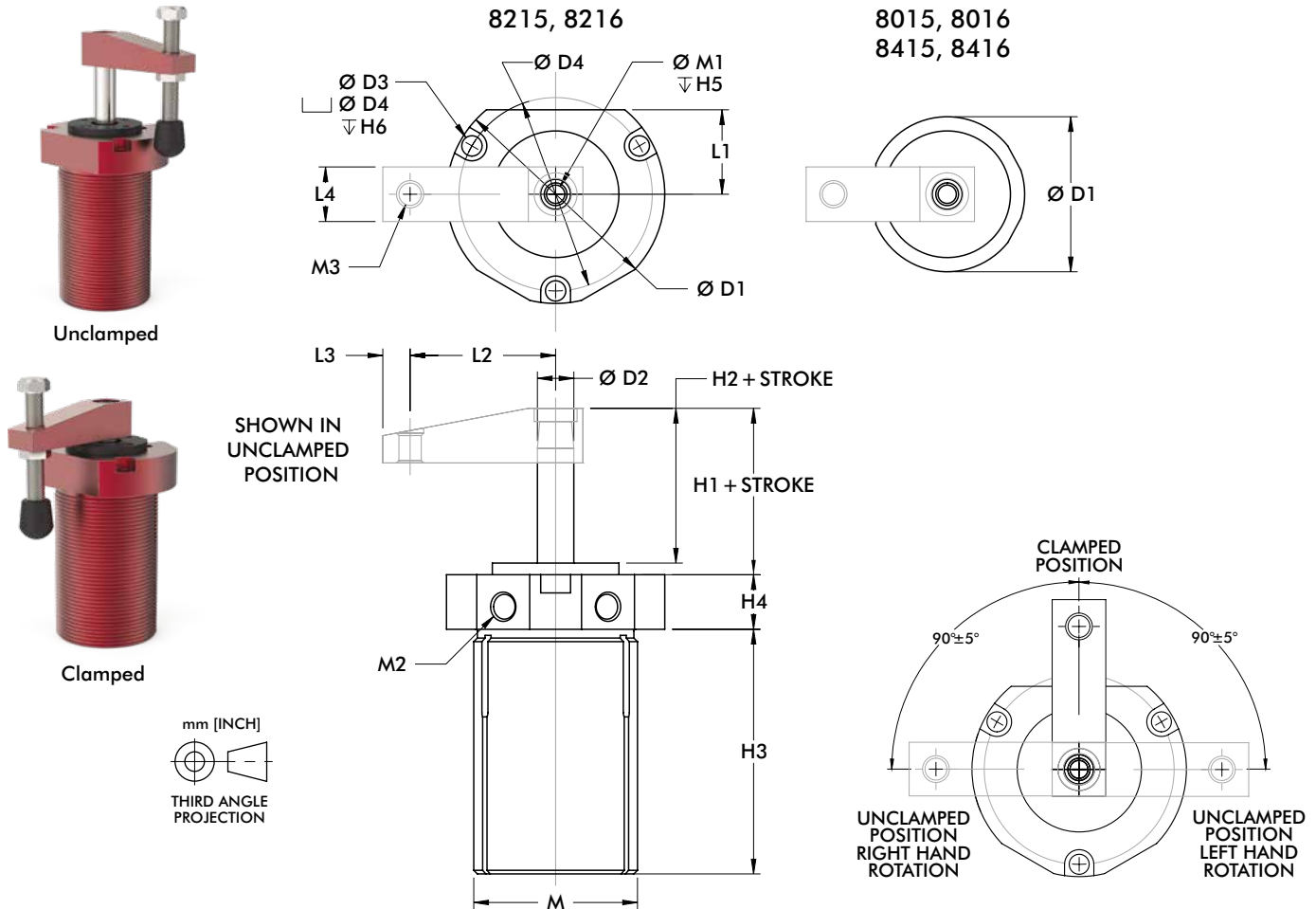

Model	ØD1	ØD2	ØD3	ØD4	Stroke	H1	H2	H3	H4	H5	H6	L1
8015	[1.25]	[0.44]	--	--	[0.85]	[0.53]	[0.41]	[2.87]	[0.50]	[0.75]	--	--
8016	31,8	11,1	--	--	21,5	13,5	10,4	72,9	12,7	19,1	--	--
8215	[3.00]	[0.50]	[0.28]	[2.66]	[1.25]	[0.97]	[0.81]	[3.36]	[0.75]	[0.67]	[0.25]	[1.16]
8216	76,2	[0.50]	7,1	67,6	31,8	24,6	20,6	85,3	[0.75]	[0.67]	6,4	29,5
8415	[2.13]	12,7	--	--	[0.94]	[0.94]	[0.78]	[3.17]	19,1	17	--	--
8416	54,1	12,7	--	--	31,8	23,9	19,8	80,5	19,1	17	--	--

Model	L2	L3	L4	M	M1	M2	M3
8015	[1.12]	[0.31]	[0.62]	1-1/8-16	¼-20	#10-32	#10-32
8016	28,4	7,9	[0.62]	1-1/8-16	¼-20	#10-32	#10-32
8215	[2.00]	[0.38]	[0.75]	2-1/4-12	5/16-18	1/8 NPT	3/8-16
8216	50,8	[0.38]	[0.75]	2-1/4-12	5/16-18	1/8 NPT	3/8-16
8415	[1.56]	9,6	19,1	1-3/4-12	5/16-18	1/8 NPT	3/8-16
8416	39,6	9,6	19,1	1-3/4-12	5/16-18	1/8 NPT	3/8-16

Mounting Options

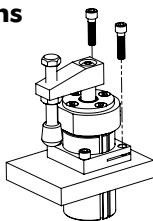

8000, 8200, 8400
Mounted into a tapped hole or a through a clearance hole with the optional mounting flange. Jam nuts are available for 8000.

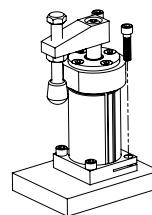

8200 only
Mounted through a clearance hole using mounting screws in the top flange.

8000, 8200, 8400 SERIES

Pneumatic Swing Clamps | Clamping Forces

Series 8000, 8200, 8400 Clamping Force
(w/ standard clamping arm)

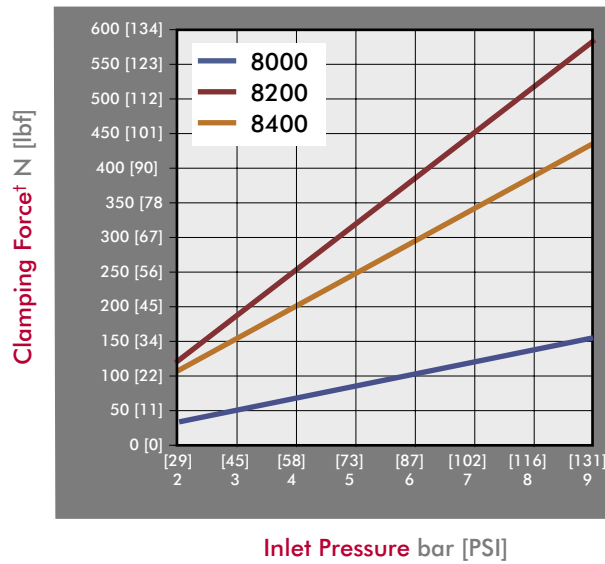

Guidelines

DESTACO Pneumatic Swing Clamps are designed for long life when using standard clamping arms and spindles. In the event that a longer arm or additional weight is needed, please consult these charts for the allowable weight and length.

Example: 8215

At a weight of 80 gr, the maximum length of the arm is approximately 90mm.

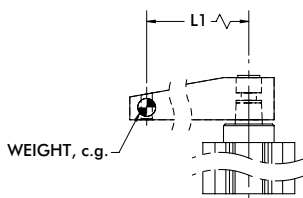

All data refers to an operating pressure of 5 bar [72psi] and an opening and closing time of 1 second.

8015/8016 Clamp Arm Weight

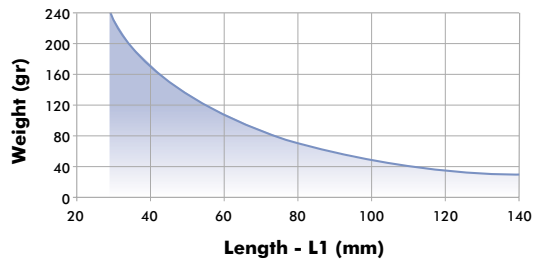

8215/8216 Clamp Arm Weight

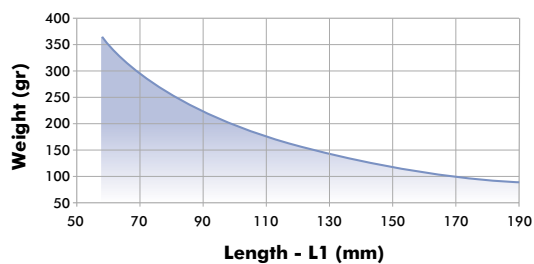

8415/8416 Clamp Arm Weight

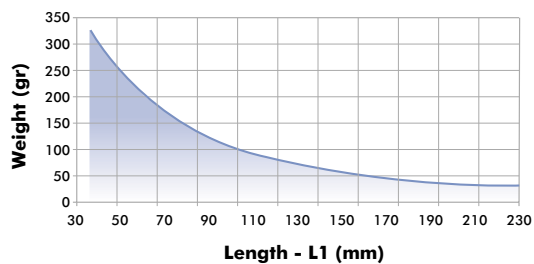

8000, 8200, 8400 SERIES



Pneumatic Swing Clamps | Clamping Arms

Features:

- Lightweight aluminum construction
- Locking tapered connection for 360 deg. arm positioning

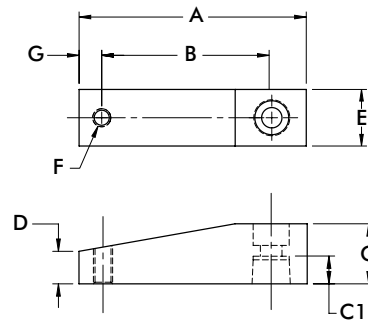

Part Number	Used with Model	A	B	C	C1	D	E	F	G	Weight [lbs] kg
801528	8015, 8016	[1.74] 44,2	[1.11] 28,2	[0.37] 9,4	[0.33] 8,3	[0.25] 6,4	[0.62] 15,7	#10-32	[0.32] 8,1	[0.03] 0,01
801529		[2.87] 72,9	[2.24] 56,9							
821512	8215, 8216, 8415, 8416	[2.75] 69,9	[2.00] 50,8	[0.75] 19,1	[0.57] 14,5	[0.38] 9,5	[0.75] 19,1	3/8-16	[0.38] 9,5	[0.04] 0,02
821513		[3.75] 95,3	[3.00] 76,2							

Clamping Arm Adapters

Features:

- For attaching custom made clamp arms
- 360° rotatable arm
- Aluminum construction

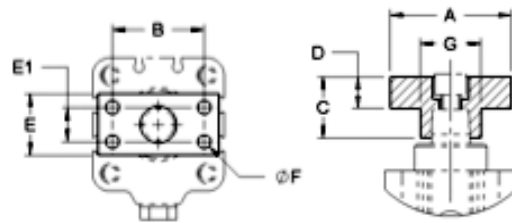
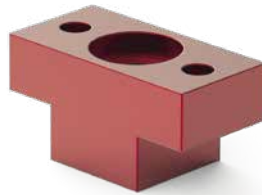

Part Number	Used with Model	A	B	C	D	E	E1	F	Weight [lbs] kg
801532	8015, 8016	[1.37] 34,8	[1.00] 25,4	[0.39]	[0.25]	[0.62]	--	#10-32 (2x)	[0.03] 0,014
821556	8215, 8216	[1.50] 38,1	[1.06] 26,9	[0.75]	[0.37]	[0.75]	--	1/4-20 (2x)	[0.05] 0,020

Mounting Flanges

Features:

- For use with Threaded Body Pneumatic Swing Clamps
- Variable height adjustment
- For recessed mounting

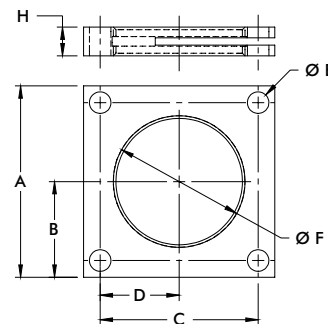

Part Number	Used with Model	A	B	C	D	E	F	H
801553	8015, 8016	[1.38] 35	[0.69] 17,5	[1.08] 27,4	[0.54] 13,7	[0.20] 5,1	1 1/8-16	[0.50] 12,7
821553	8215, 8216	[2.50] 63,5	[1.25] 31,8	[2.12] 53,8	[1.06] 26,9	[0.28] 7,1	2 1/4-12	
841550	8415, 8416	[2.00] 50,8	[1.00] 25,4	[1.60] 40,6	[0.80] 20,3		1 3/4-12	

Dimensions and technical information are subject to change without notice