

201 Series



Vertical Hold Down Clamps | Product Overview

Features:

- Smallest series in the Vertical Handle series
- Stainless steel version available

Applications:

- Checking fixtures
- Assembly & test
- Woodworking

Also Available:

See page MC-ACC-1 for accessories

812-U Pneumatic Toggle Clamp
(See page MC-PTC-3)

201-U
Flanged Base
U-Bar



201-UB
Straight Base



201-TU
Flanged
Base, U-Bar,
T-Handle



201-USS
Flanged Base
U-Bar, Stainless
Steel



Technical Information

Model	Max. Holding Capacity	Clamp Bar Opening (+10°)	Handle Opening (+10°)	Weight	Accessories (Supplied)	
					Spindle Assembly	Flanged Washers
201-U	440 N [100 lbf]	100°	55°	0,70kg [0.15lbs]	305208-M	102111
201-UB						
201-TU						
201-USS	560 N [125 lbf]				201943-M	102911

Holding Capacities

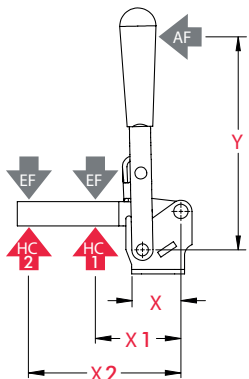

Model	X	X1	X2	Y	‡HC1	‡HC2	‡EF(X1):AF	‡EF(X2):AF
U/UB				[2.25] 57	[100lbf.] 440N	[55lbf.] 245N	9:1	6:1
TU	[0.87] 22	[1.06] 27	[1.75] 44,5	[1.38] 35			8.4:1	4:4:1
USS				[2.25] 57	[125lbf.] 560N	[60lbf.] 270N	9:1	6:1

Dimensions shown "mm [inch]" ‡ HC = Holding Capacity, EF = Exerting Force, AF = Applied Force
See page MC-TEC-4 for additional information.

201-U
Flanged Base
U-Bar

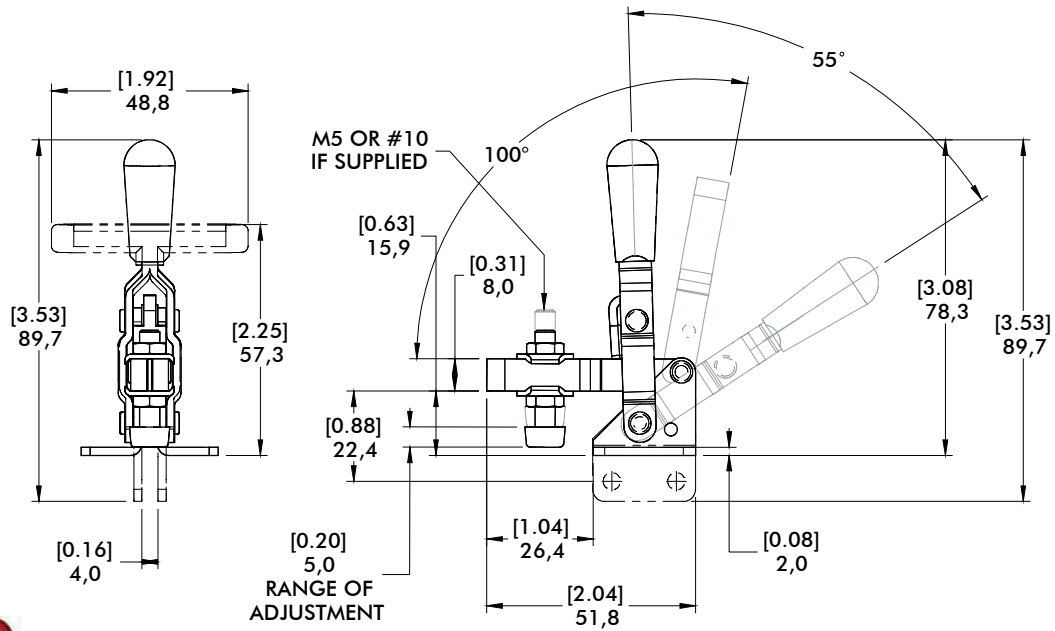
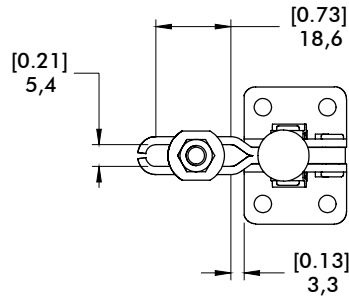

201-UB
Straight Base

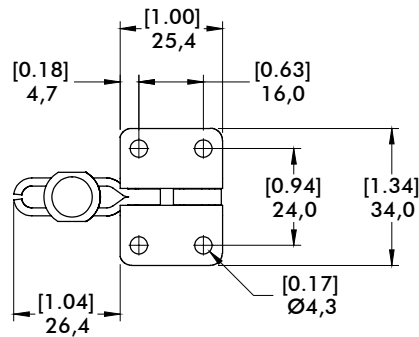

mm [INCH]
THIRD ANGLE
PROJECTION