

202 SERIES



Vertical Hold Down Clamps | Product Overview

Features:

- Large hand clearance for improved safety
- Bolt pattern interchangeable with 202 Series
- Three times the holding capacity of 202 Series
- Hardened bushings at key pivot points
- Near vertical clamping contact
- BLK models feature a black, non-reflective finish

Applications:

- Checking fixtures
- Assembly & test
- Light machining
- Woodworking

Also Available:

See page MC-ACC-1 for accessories
Accepts M6 or 1/4 spindle accessories

Covered under one or more U.S./International Patents

2002-U
Flanged
Base
U-Bar



2002-U-LS-BLK ⓘ
Blackout Series
Flanged Base
U-Bar



2002-S
Flanged Base
Solid Bar



2002-UB
Straight Base
U-Bar



2002-UB-LS-BLK ⓘ
Blackout Series
Straight Base
U-Bar



2002-SB
Straight Base
Solid Bar



2002-UR
Flanged Base
U-Bar
with
DESTACO®
Toggle Lock
Plus



2002-SR ⓘ
Flanged Base
Solid Bar
with
DESTACO®
Toggle Lock
Plus



2002-UBR
Straight Base
U-Bar
with
DESTACO®
Toggle Lock
Plus



2002-SBR ⓘ
Straight Base
Solid Bar
with
DESTACO®
Toggle Lock
Plus



2002-U207
Flanged Base
U-Bar
Interchangeable
with 207 Series



2002-UR207
Flanged Base
U-Bar
Interchangeable
with 207 Series,
DESTACO®
Toggle
Lock Plus



ⓘ This item is available upon request

2002 SERIES

Vertical Hold Down Clamps | Technical Information

Model	Max. Holding Capacity	Clamp Bar Opening(+10°)	Handle Opening (+10°)	Weight	Accessories (Supplied)		
					Bolt Retainer	Spindle Assembly	Flanged Washers
2002-U	2700 N [600 lbf]	75°	66°	0,22kg [0.48lb]	--	215208-M	215105
2002-U-LS-BLK ⓘ					--	--	215105-BLK
2002-S					2002115-E	--	--
2002-UB					--	215208-M	215105
2002-UB-LS-BLK ⓘ					--	--	215105-BLK
2002-SB					2002115-E	--	--
2002-UR		--	215208-M	215105			
2002-SR ⓘ		2002115-E	--	--			
2002-UBR		--	215208-M	215105			
2002-SBR ⓘ		2002115-E	--	--			
2002-U207		90°	72°	0,26kg [0.57lb]	--	215208-M	215105
2002-UR207		75°	57°				

ⓘ This item is available upon request

Holding Capacities

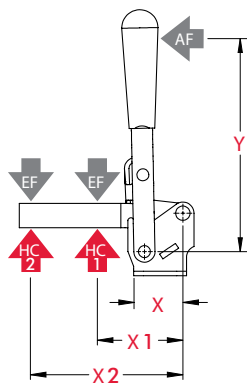

Model	X	X1	X2	Y	±HC1	±HC2	±EF(X1):AF	±EF(X2):AF
2002-()	[1.12] 28,5	[1.45] 37	[2.64] 67	[3.66] 93	[600 lbf] 2700N	[295 lbf] 1310N	11:1	5:1

Dimensions shown "mm [inch]" ± HC = Holding Capacity, EF = Exerting Force, AF = Applied Force
See page MC-TEC-4 for additional information.

2002SERIES



Vertical Hold Down Clamps | Dimensions | -U/-S/-UB/-SB/-UR/-SR/-UBR/-SBR

2002-U

Flanged Base
U-Bar

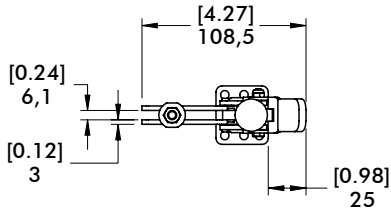

DESTACO®
TOGGLE LOCK
PLUS OPTION

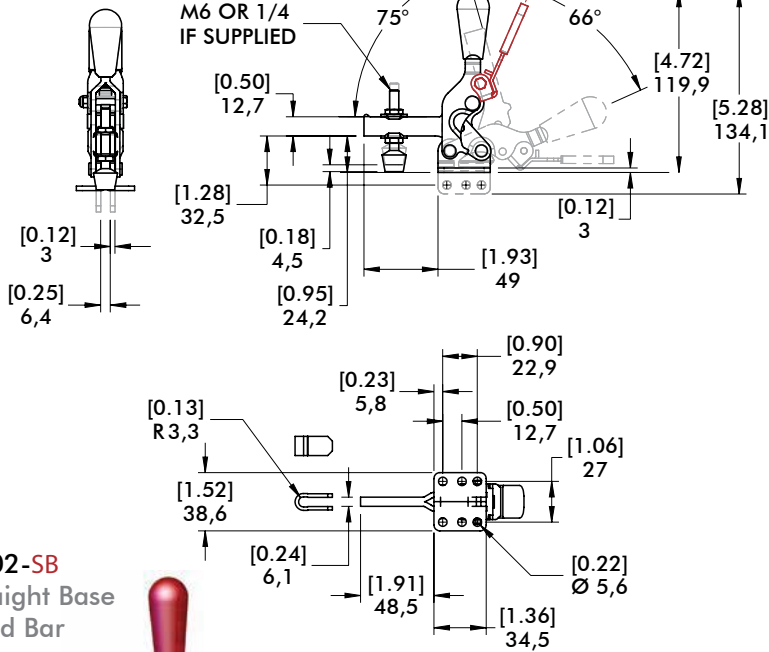

2002-SB
Straight Base
Solid Bar

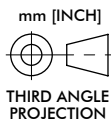

2002-U207/2002-UR207 with interchangeable Series 207 Mounting Pattern

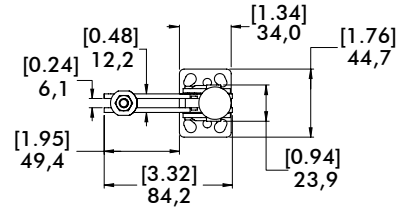

DESTACO®
TOGGLE LOCK
PLUS OPTION

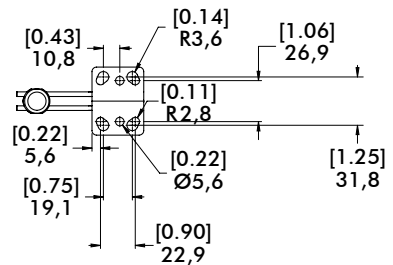
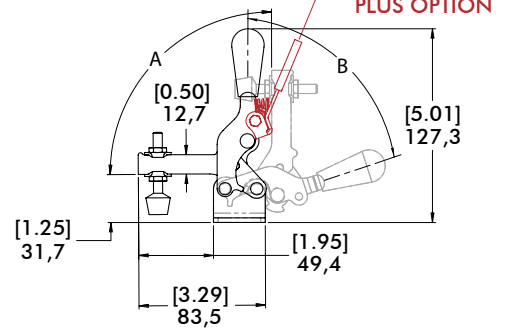

Model	A	B
2002-U-207	90°	72°
2002-UR207	75°	57°