

VDR22 Design Series Variable Volume Vane Pump

30ℓ/min 14MPa
40ℓ/min 7MPa

Features

① Stable, highly efficient operation up to 14MPa

A biased piston that minimizes ring vibration and leak-free pressure balance construction enables highly efficient highpressure operation, and very stable performance up to 14MPa.

② High-precision instantaneous response

Response has been improved by a special bias piston mechanism. Prompt response at both ON-OFF and OFF-ON ensures instantaneous, stable,

high-precision operation.

③ Silent operation, even in the high pressure range

Quiet journal bearings, a bias piston that allows a 3-point support system, and new suction and discharge port shapes all contribute to minimize operation noise. Silent, vibration-free operation is ensured, even in the high pressure range.

④ Reduced power loss

A combination of NACHI-original mechanical innovations and precision machining create a pump that minimizes power loss, especially at full cutoff.

⑤ Solid construction stands up to harsh operating conditions

The tough and rugged construction of this pump is made possible by a long history of quality pump designs. This, in combination with specially selected materials and skilled workmanship, provides outstanding durability.

Specifications

Single Pump

Model No.	Capacity cm ³ /rev	No-load Discharge Rate ℓ/min				Pressure Adjustment Range MPa(kgf/cm ²)	Allowable Peak Pressure MPa(kgf/cm ²)	Revolution Speedmin ⁻¹		Weight kg
		1000min ⁻¹	1200min ⁻¹	1500min ⁻¹	1800min ⁻¹			Min.	Max.	
VDR-1A(B)-1A2-22 1A3 1A4 1A5	16.7	16.7	20	25	30	1.5 to 3.5 {15.3 to 35.7} 3 to 7 {30.6 to 71.4}	14 {143}	800	1800	9
						6.5 to 10.5 {66.3 to 107} 9 to 14 {91.8 to 143}	21 {214}			
VDR-1A(B)-2A2-22 2A3	22	22	27	33	40	1.5 to 3.5 {15.3 to 35.7} 3 to 7 {30.6 to 71.4}	14 {143}	800	1800	9

Double Pump

Model No.	Vent Side		Shaft Side		Vent Side	Shaft Side	Revolution Speedmin ⁻¹		Weight kg
	Discharge Rate ℓ/min	Pressure Adjustment Range MPa(kgf/cm ²)	Discharge Rate ℓ/min	Pressure Adjustment Range MPa(kgf/cm ²)			Min.	Max.	
VDR-11A(B)-1A2-1A2-22 VDR-11A(B)-1A2-1A3-22	30	1.5 to 3.5 {15.3 to 35.7}	30	1.5 to 3.5 {15.3 to 35.7} 3 to 7 {30.6 to 71.4}	14 {143}	800	1800	17	
VDR-11A(B)-1A3-1A3-22		3 to 7 {30.6 to 71.4}		3 to 7 {30.6 to 71.4}					
VDR-11A(B)-2A2-2A2-22 VDR-11A(B)-2A2-2A3-22	40	1.5 to 3.5 {15.3 to 35.7}	40	1.5 to 3.5 {15.3 to 35.7} 3 to 7 {30.6 to 71.4}	14 {143}	800	1800	17	
VDR-11A(B)-2A3-2A3-22		3 to 7 {30.6 to 71.4}		3 to 7 {30.6 to 71.4}					

Note) 1. The discharge rate is the value at 1800min⁻¹ no-load.

2. The change from design number 21 to design number 22 represents a change in the shaft key width from 3.2mm to 4.76mm. This means that when using a 3.2mm key coupling, you need to use a stepped key (VD31J-301000) or add a new key groove at 4.76.

● Handling

① Rotation Direction

The direction of rotation is always clockwise (rightward) when viewed from the shaft side.

② Drain

Drain piping must be direct piping up to a point that is below the tank fluid level, and back pressure due to pipe resistance should not exceed 0.03MPa. When using a pump that has drain ports at two locations, use the drain port that is higher after the pump is installed.

③ Discharge Volume Adjustment

The discharge flow rate is decreased by clockwise (rightward) rotation of the discharge rate adjusting screw, and increased by counterclockwise (leftward) rotation. Loosen the lock nut before making adjustments. After adjustment is complete, re-tighten the lock nut. The graph on the right provides general guidelines for the relationship between the rotation angle of the flow rate adjusting screw and the no-load discharge rate.

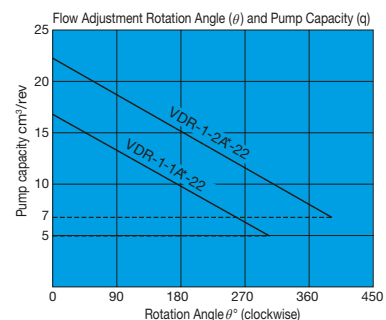

(Continued on following page)

However: $Q=q \times n \times 10^{-3}$

Q : No-load Discharge Rate Q ℓ/min

q : Volume cm³/rev

N : Revolution Speed min⁻¹

The broken line shows the flow volume adjustment range lower limit value.

Note) The values indicated above are at maximum discharge volume with the flow volume adjusting screw at the 0° position.

4 Pressure Adjustment

Pressure is decreased by clockwise (rightward) rotation of the discharge rate adjusting screw, and increased by counterclockwise (leftward) rotation.

5 Factory Default P-Q Settings (Standard Model)

- Flow Rate Setting = Maximum flow rate for model as indicated in the catalog
- Pressure Setting = Pressure shown in table to the right

6 Thrust Screw

The thrust screw is precisely adjusted at the factory during assembly. Never touch the thrust screw. See callout ② in the crosssection diagram on page B-11.

7 Initial Operation

Before operating the pump for the first time, put the pump discharge

Factory Default Pressure Settings MPa{kgf/cm ² }
2 : 3.5{35.7}
3 : 3 {30.6}
4 : 6.5{66.3}
5 : 9 {91.8}

side into the no-load state and then repeatedly start and stop the motor to bleed all air from inside the pump and the suction piping. After confirming that the pump is discharging oil, continue the no-load operation for at least 10 minutes to discharge all the air from the circuit.

Provide an air bleed valve in circuits where it is difficult to bleed air before startup.

8 Sub Plate

Use the following table for specification when a sub plate is required.

For detailed dimensions, see pages B-17 through B-19.

Pump Model No.	Sub Plate Number	Motor(kW)
VDR-1A-1A*-22	MVD-1-115-10	0.75 to 1.5
	MVD-1-135-10	2.2 to 3.7
VDR-1A-2A*-22	MVD-1-115Y-10	0.75 to 1.5
	MVD-1-135Y-10	2.2 to 3.7
VDR-11A-*A*-22	MVD-11-135-10	1.5 to 3.7
	MVD-11-135X-10	

9 For the hydraulic operating fluid, use type ISO VG32 or equivalent (viscosity index of at least 90) for pressures of 7MPa or lower, and type ISO VG68 or equivalent (viscosity index of at least 90) for pressures greater than 7MP.

10 The operating temperature range is 15 to 60°C. When the oil temperature at startup is 15°C or less, perform a warm-up operation at low pressure until the oil temperature reaches 15°C. Use the pump in an area where the temperature is within the range of 0 to 60°C.

11 Suction pressure is -0.03 to +0.03MPa (-0.3 to +0.3kgf/cm²), and the suction port flow rate should be to greater than 2m/sec.

12 Avoid pulley, gear, and other drive systems that impart a radial or thrust load on the end of the pump shaft. Mount the pump so its pump shaft is oriented horizontally.

13 Provide a suction strainer with a filtering grade of about 100 μm (150 mesh). For the return line to the tank, use a 25μm line filter.

(Continued on following page)

Explanation of model No.

Single pump

VDR - 1 A - 1 A 2 - 22

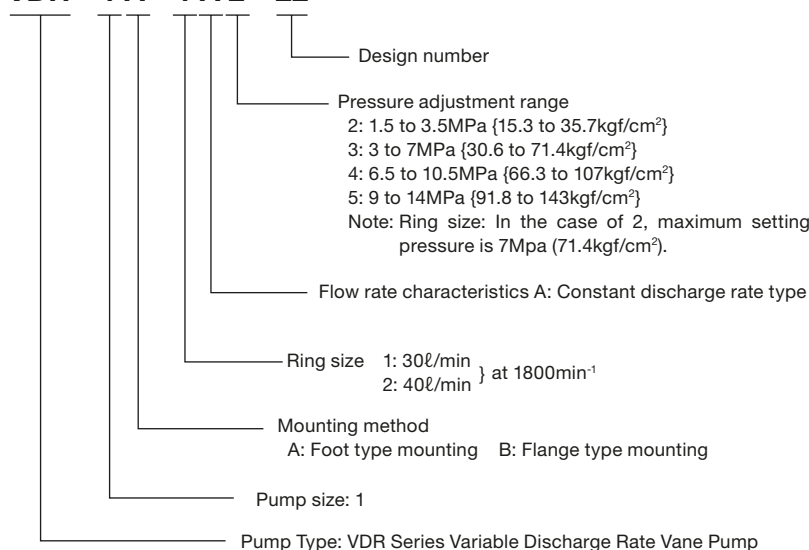

Double pump

VDR - 11 A - 1 A 2 - 1 A 3 - 22

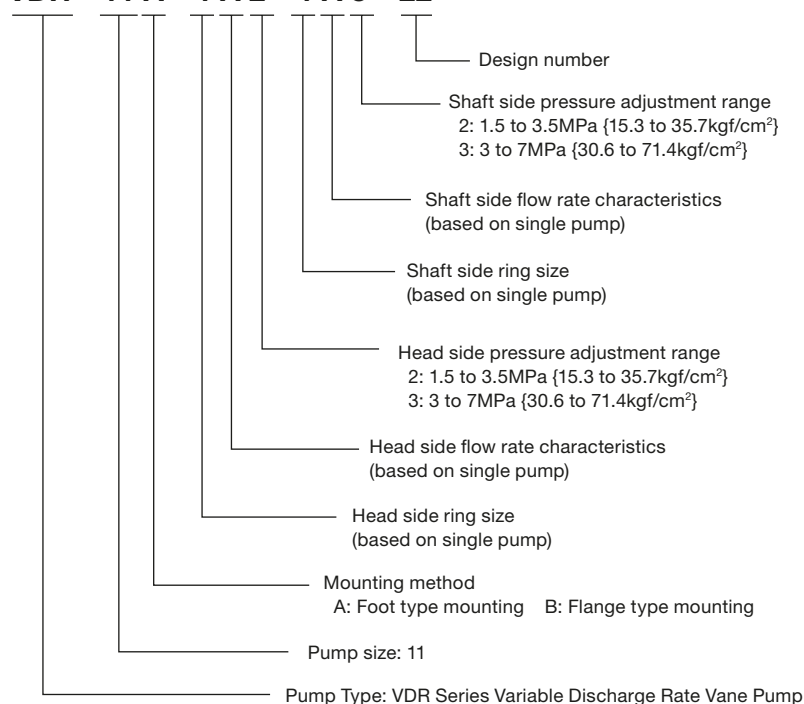

- 14 Manage hydraulic operating fluid so contamination is maintained at class NAS10 or lower. Take care to avoid contamination with water or other foreign matter, and watch out for discoloration. Whitish fluid indicates that air has contaminated the fluid, and brownish fluid indicates the fluid is dirty.
- 15 Contact your agent about using water and glycol-based hydraulic operating fluids.
- 16 At startup, repeat the inching operation (start-stop) to prime the pump

- and bleed air from the pump and pipes. (This pump has no fluid supply port.)
- 17 Equip an air bleed valve in circuits where it is difficult to bleed air before startup. See page C-13 for more information.
- 18 When centering the pump shaft, eccentricity with the motor shaft should be no greater than 0.05mm. Use a pump mounting base of sufficient rigidity. The angle error should be no greater than 1°.

● Inverter Drive Precautions

- 1 Set the revolution speed within the range of the pump specification revolution speed.
- 2 Changing the revolution speed may also affect the pump performance curves. Before using the inverter, check if the pressure and motor load factor are within the range of use.

Installation Dimension Drawings

VDR-1A-*A*-22

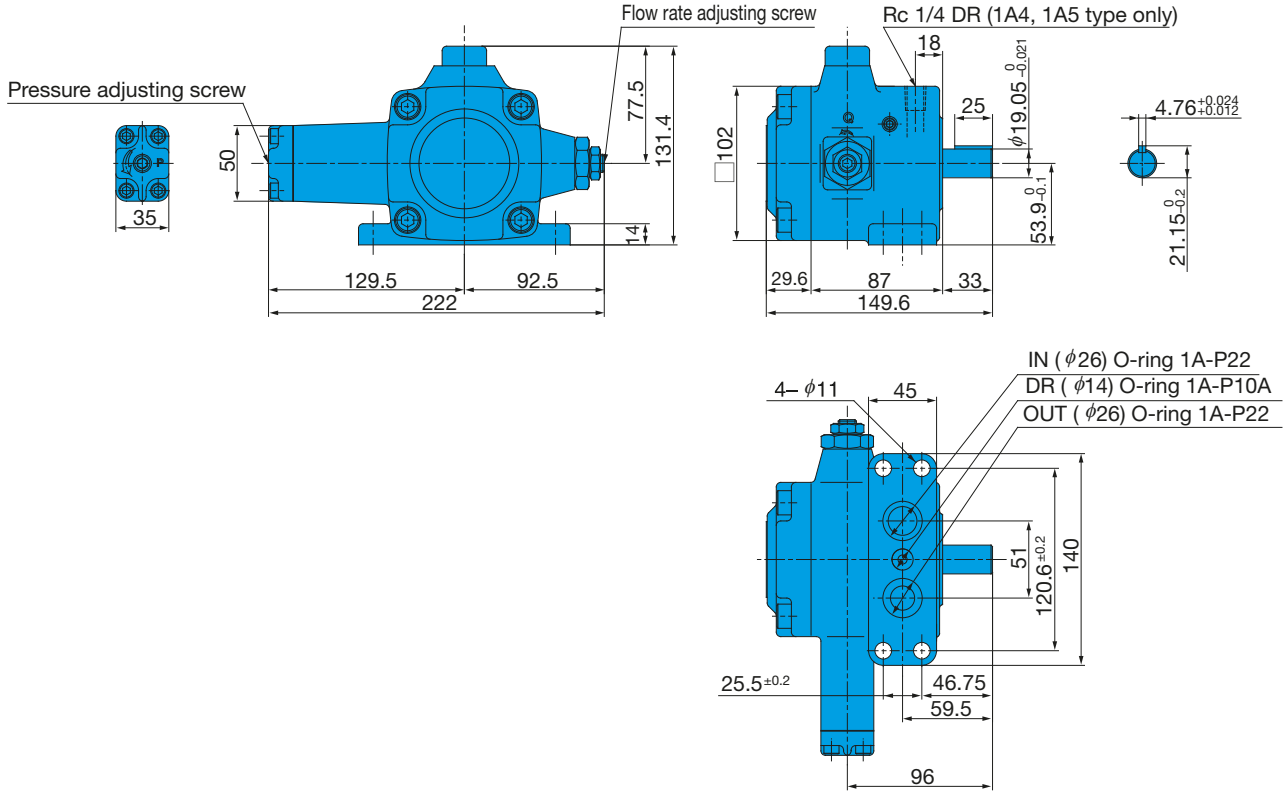

VDR-1B-*A*-22

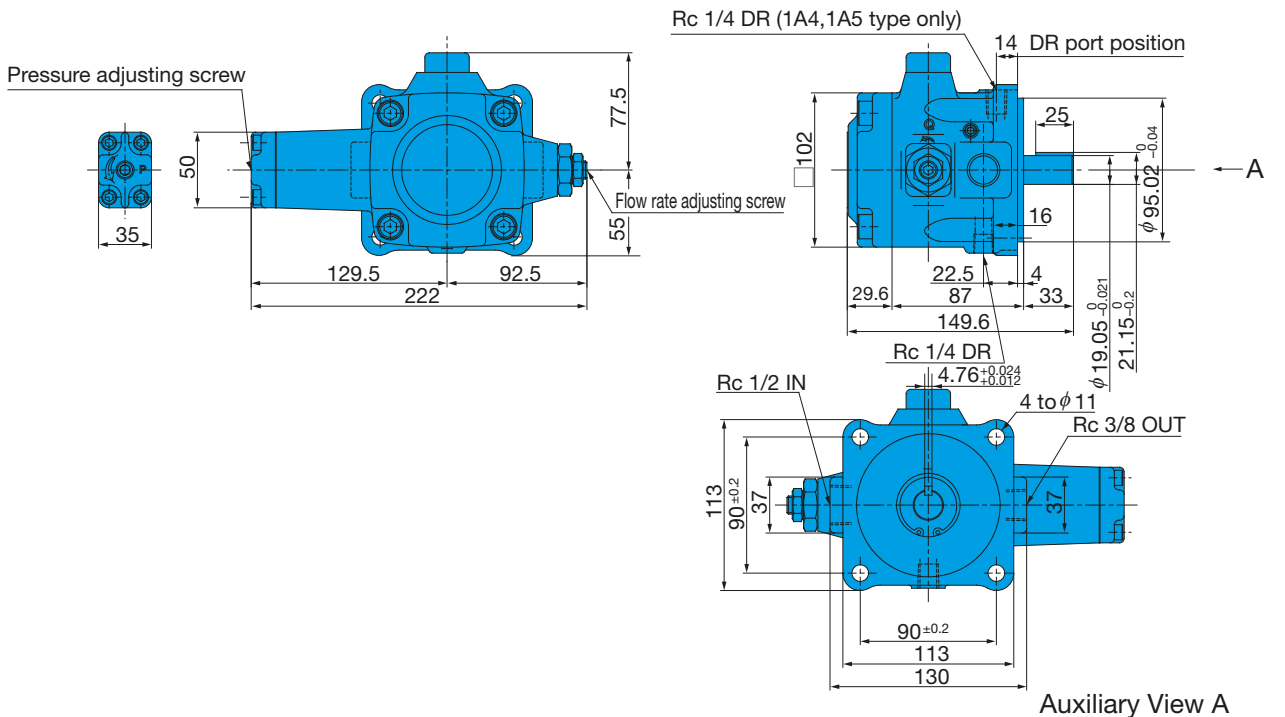

VDR-11A-*-*-22

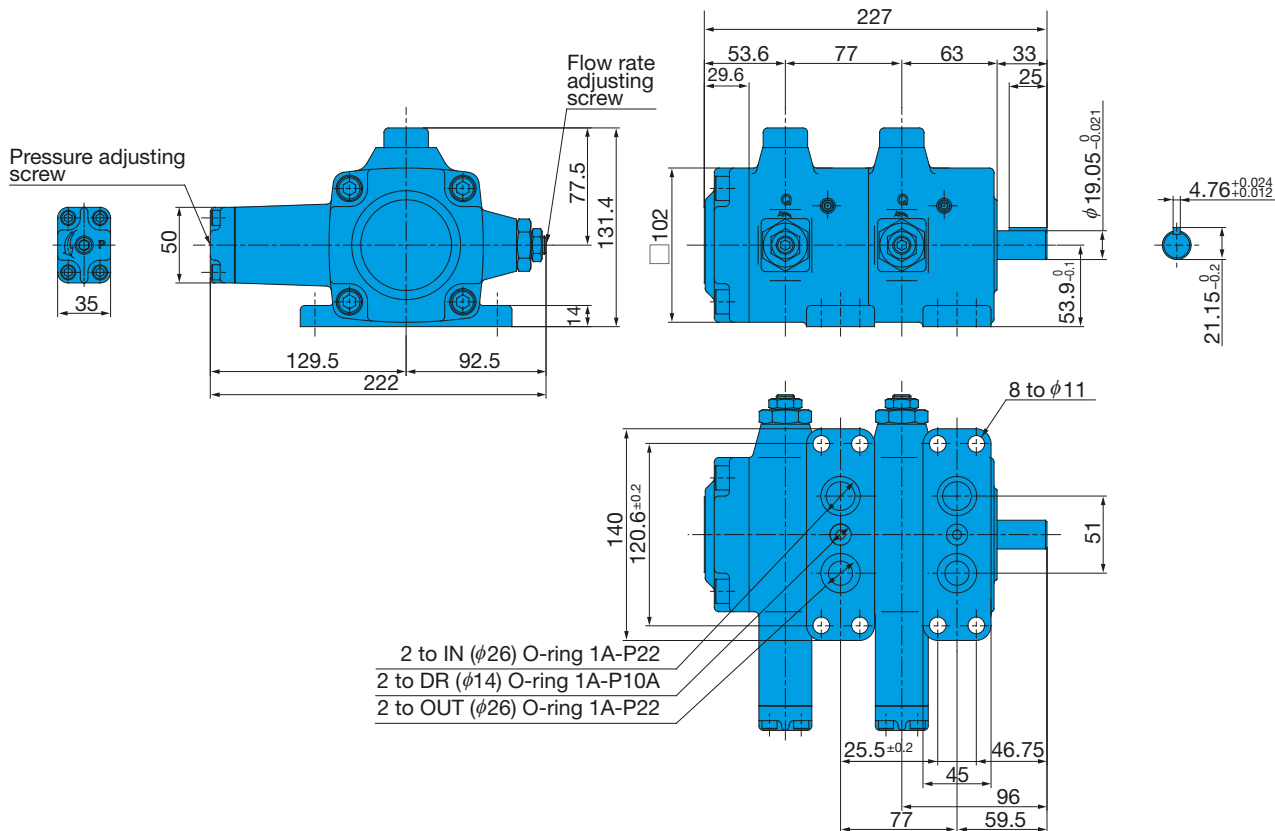

VDR-11B-*-*-22

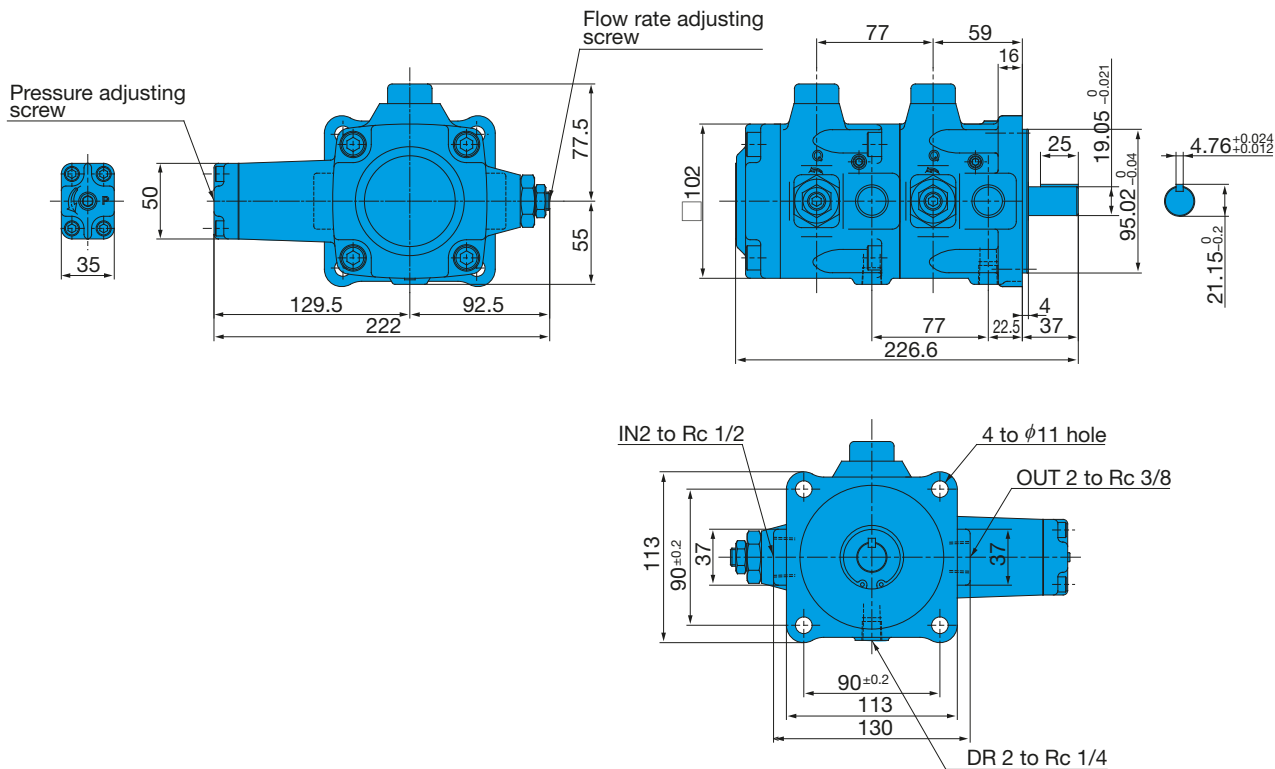

Performance Curves

Typical characteristics at hydraulic operating fluid kinematic viscosity of 32 mm²/s

VDR-1*-1A2-22

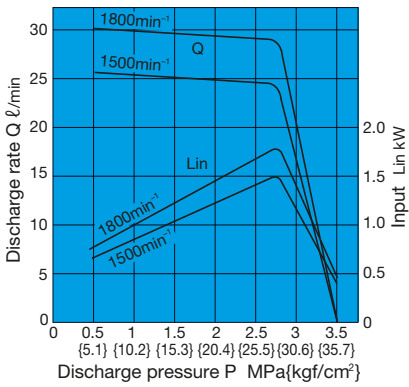

VDR-1*-1A3-22

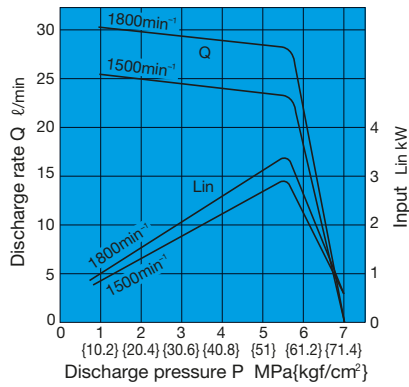

VDR-1*-1A4-22

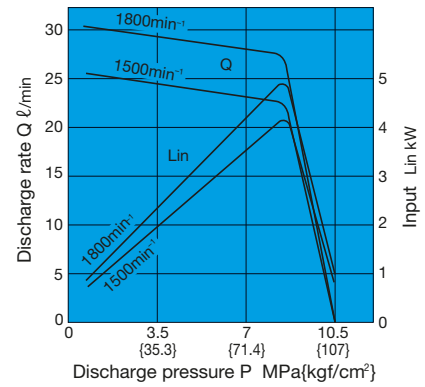

VDR-1*-1A5-22

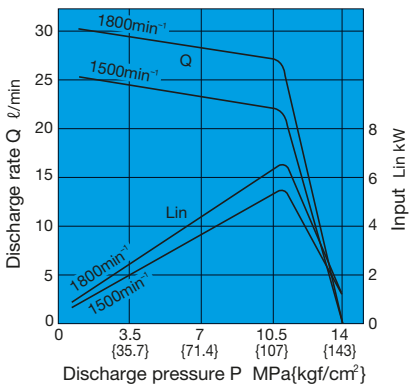

VDR-1*-2A2-22

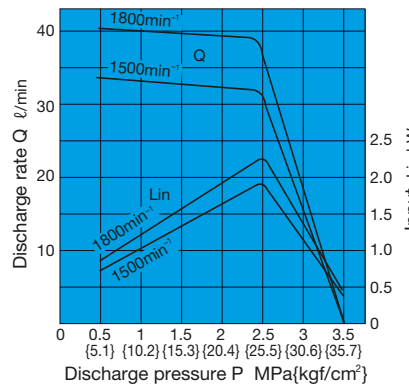

VDR-1*-2A3-22

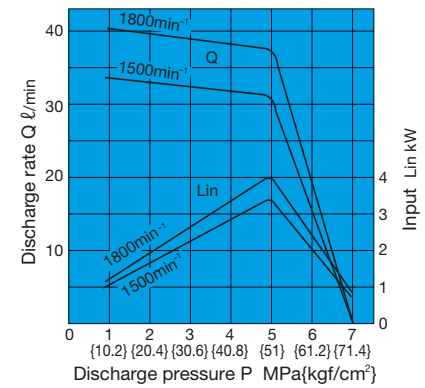

Axial Input At Full Cutoff

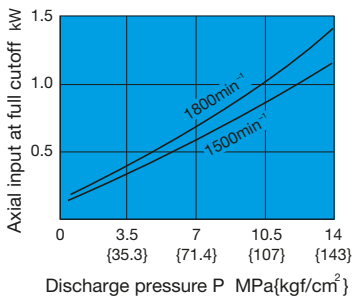

Noise Characteristics

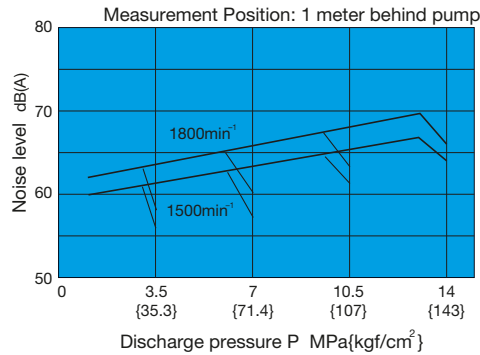

Cross-sectional Drawings

VDR-1A-*A*-22

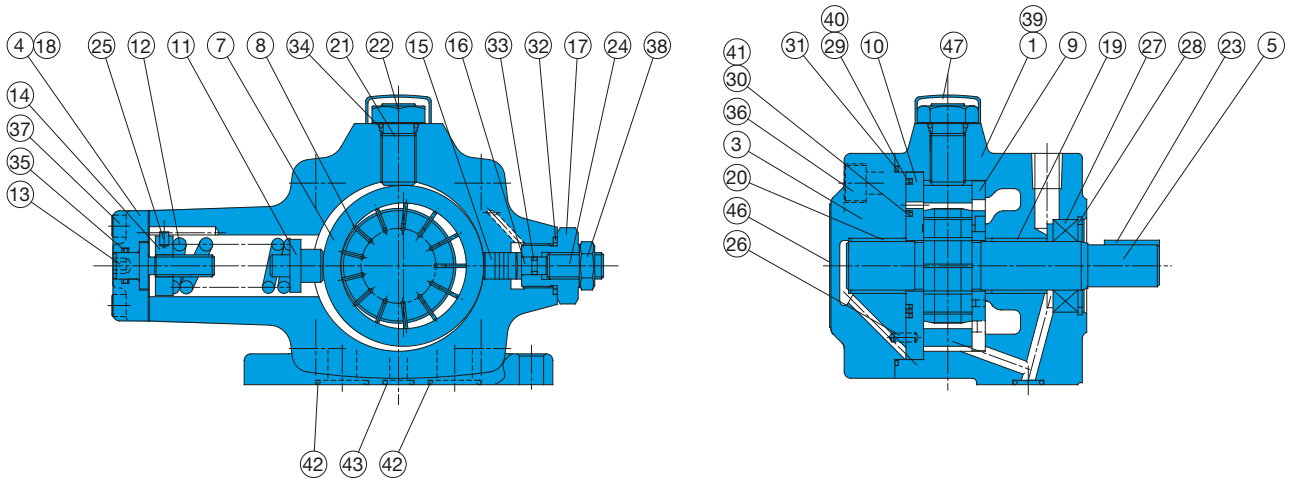

List of Sealing Parts

Single Pump

Part No.	Applicable Pump Model No. VDR-1A-*A*-22		
	Seal Kit Number VDBS-101A00		
	Part Name	Part Number	Q'ty
18	Packing	VDB32-101000	1
27	Oil seal	ISP1D-224211F	1
29	Backup ring	VDB34-101000	1
30	Backup ring	VDB34-201000	1
31	O-ring	S85(NOK)	1
32	O-ring	NBR-70-1 P22	1
33	O-ring	NBR-70-1 P5	1
34	O-ring	NBR-70-1 P14	1
35	O-ring	NBR-70-1 P12	1
40	O-ring	AS568-036	1
41	O-ring	AS568-029	1
42	O-ring	NBR-70-1 P22	2
43	O-ring	NBR-70-1 P10A	1

- Note) 1. Oil seals are manufactured by Nippon Oil Seal Industry Co. Ltd. (NOK).
 2. The materials and hardness of the O-ring conform with JIS B2401.
 3. For VDR-1B-*A*-22, the seal kit number becomes VDBS-101B00, without the 42 and 43 O-rings.

Part No.	Part Name	Part No.	Part Name
1	Body (A)	25	Pin
2	Body (B)	26	Spring pin
3	Cover	27	Oil seal
4	Cover	28	Snap ring
5	Shaft	29	Backup ring
6	Rotor	30	Backup ring
7	Ring	31	O-ring
8	Vane	32	O-ring
9	Plate (S)	33	O-ring
10	Plate (H)	34	O-ring
11	Piston	35	O-ring
12	Spring	36	Screw
13	Screw	37	Screw
14	Nut	38	Nut
15	Piston	39	Plug
16	Holder	40	O-ring
17	Adapter	41	O-ring
18	Packing	42	O-ring
19	Bearing (S)	43	O-ring
20	Bearing (H)	44	Screw
21	Thrust screw	45	Key
22	Nut	46	Nameplate
23	Key	47	Cap
24	Screw	48	Pin

Double Pump

Part No.	Applicable Pump Model No. VDR-11A-*A*-22		
	Seal Kit Number VDBS-111A00		
	Part Name	Part Number	Q'ty
18	Packing	VDB32-101000	2
27	Oil seal	ISP1D-224211F	1
29	Backup ring	VDB34-101000	2
30	Backup ring	VDB34-201000	2
31	O-ring	S85(NOK)	2
32	O-ring	NBR-70-1 P22	2
33	O-ring	NBR-70-1 P5	2
34	O-ring	NBR-70-1 P14	2
35	O-ring	NBR-70-1 P12	2
40	O-ring	AS568-036	2
41	O-ring	AS568-029	2
42	O-ring	NBR-70-1 P22	4
43	O-ring	NBR-70-1 P10A	2

- Note) 1. Oil seals are manufactured by Nippon Oil Seal Industry Co. Ltd. (NOK).
 2. The materials and hardness of the O-ring conform with JIS B2401.
 3. For VDR-11B-*A*-22, the seal kit number becomes VDBS-111B00, without the 42 and 43 O-rings.



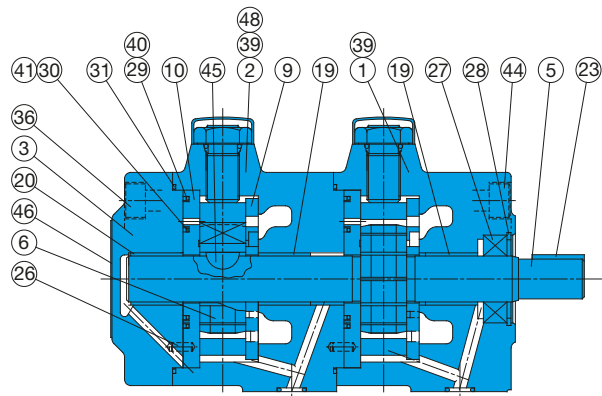
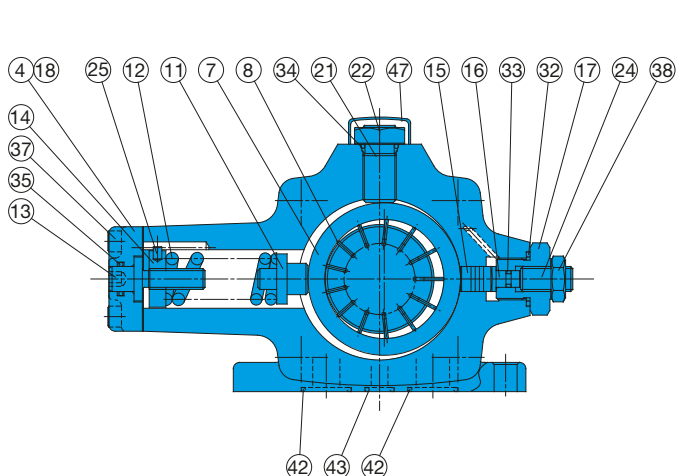

Uni-pump Specifications

(CE mark standard compliant)

Understanding Model Numbers

Single Pump

UVD -1 A - 2 A 2 - 1.5 - 4 - 60

- Design number
- Number of motor poles: 4 (P)
- Motor output (kW)
0.75, 1.5, 2.2, 3.7
- Pressure adjustment range
2: 1.5 to 3.5MPa {15.3 to 35.7kgf/cm²}
3: 3.0 to 7.0MPa {30.6 to 71.4kgf/cm²}
- Flow characteristics A: Constant discharge type
- Ring size
None : 30ℓ/min } at 1800min⁻¹
2 : 40ℓ/min }
- A: Foot type mounting
- Pump size 1: VDR-1B (22D)
- Pump Type: VDR (22D) Series Uni-pump

Double Pump

UVD - 11 A - 2 A 2 - 2 A 2 - 3.7 - 4 - 60

- Design number
- Number of motor poles: 4 (P)
- Motor output (kW)
1.5, 2.2, 3.7
- Shaft side pump pressure adjustment range
2: 1.5 to 3.5MPa {15.3 to 35.7kgf/cm²}
3: 3.0 to 7.0MPa {30.6 to 71.4kgf/cm²}
- Shaft side pump flow rate characteristics
A: Constant discharge type
- Shaft side pump ring size
None: 30ℓ/min } at 1800min⁻¹
2 : 40ℓ/min }
- Head side pump pressure adjustment range:
Same as the shaft side pump
- Head side pump flow rate characteristics
A: Constant discharge type
- Head side pump ring size
None: 30ℓ/min } at 1800min⁻¹
2 : 40ℓ/min }
- A: Foot type mounting
- Pump size 11: VDR-11B (22D)
- Pump Type: VDR (22D) Series Uni-pump

Specifications

Model No.	Maximum Working Pressure MPa(kgf/cm ²)	Maximum Flow Rate ℓ/min (A*)		Maximum Flow Rate ℓ/min (2A*)	
		50Hz	60Hz	50Hz	60Hz
UVD-1A	7 {71.4}	25	30	33	39
UVD-11A	7 {71.4}	25-25	30-30	33-33	39-39

Motor selection curves

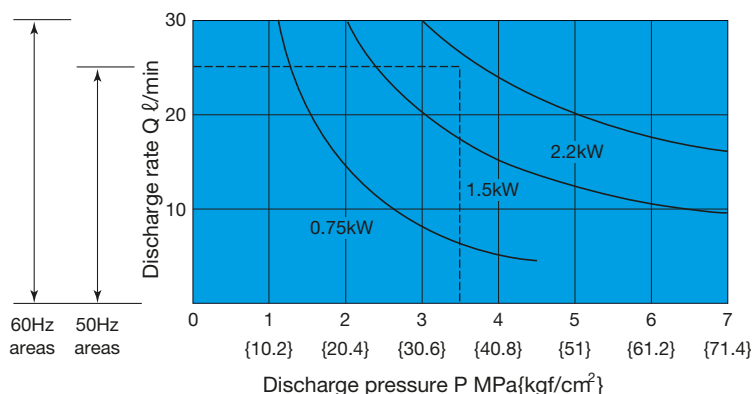

● **Selecting a motor**

The area under a motor output curve in the graph to the left is the operating range for that motor under the rated output for that motor.

Example:

To find the motor that can produce pressure of 3.5MPa and a discharge rate of 25l/min.

Selection Process

Since the intersection of the two broken lines from a pressure of 3.5MPa and discharge rate of 25l/min intersect in the area under the 2.2kW curve, it means that a 2.2kW motor should be used. In the case of a double pump configuration, select a motor that is larger than the total power required by both pumps.

- * Select a uni-pump that has a pressure and flow rate that is within the range of the drive so that the drive will not overload.
- * When the startup current of the uni-pump becomes higher for the IE1 motor, breakers may need to be changed.

Installation Dimension Drawings

UVD-1A

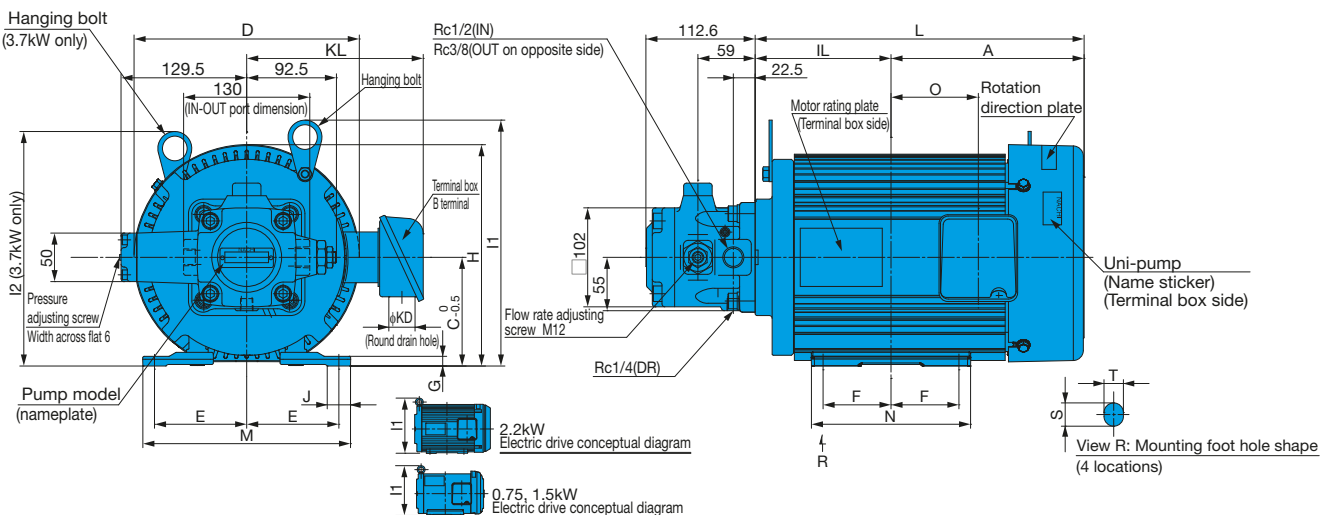

Uni-pump	Motor Dimensions [mm]																	Frame No.	Output kW (4 poles)	Weight kg		
	A	IL	C	D	E	F	G	H	I1	I2	J	L	M	N	S×T	φKD	KL				O	
UVD-1A-A2-0.75-4-60	137	105	80	152	62.5	50	4.5	160	193	-	47.5	242	165	130	25x10	27	137	65	80M	0.75	28	
UVD-1A-A2-1.5-4-60																						
UVD-1A-A3-1.5-4-60	160.5	118.5	90	183	70	62.5	4.4	183	204	-	22	279	165	152.5	16x10	27	142	68	90L	1.5	31	
UVD-1A-2A2-1.5-4-60																						
UVD-1A-A2-2.2-4-60																						
UVD-1A-A3-2.2-4-60	179	133	100	206	80	70	7	203	226	-	39	312	206	170	14x12	27	153	83	100L	2.2	45	
UVD-1A-2A2-2.2-4-60																						
UVD-1A-A3-3.7-4-60																						
UVD-1A-2A2-3.7-4-60	199	140	112	233	95	70	10	228	253	242	24	339	214	164	14x12	27	182	90	112M	3.7	49	
UVD-1A-2A3-3.7-4-60																						

1. Standard drive motor is the fully enclosed fan-cooled F type.
2. Standard voltage for drive motor is 200 VAC, 50/60 Hz or 220 VAC, 60 Hz.
3. Standard terminal box is B terminal (right side viewed from pump).
4. See page A-21 for the characteristics of the drive motor for the unipump (domestic standard 3 rating).

UVD-11A

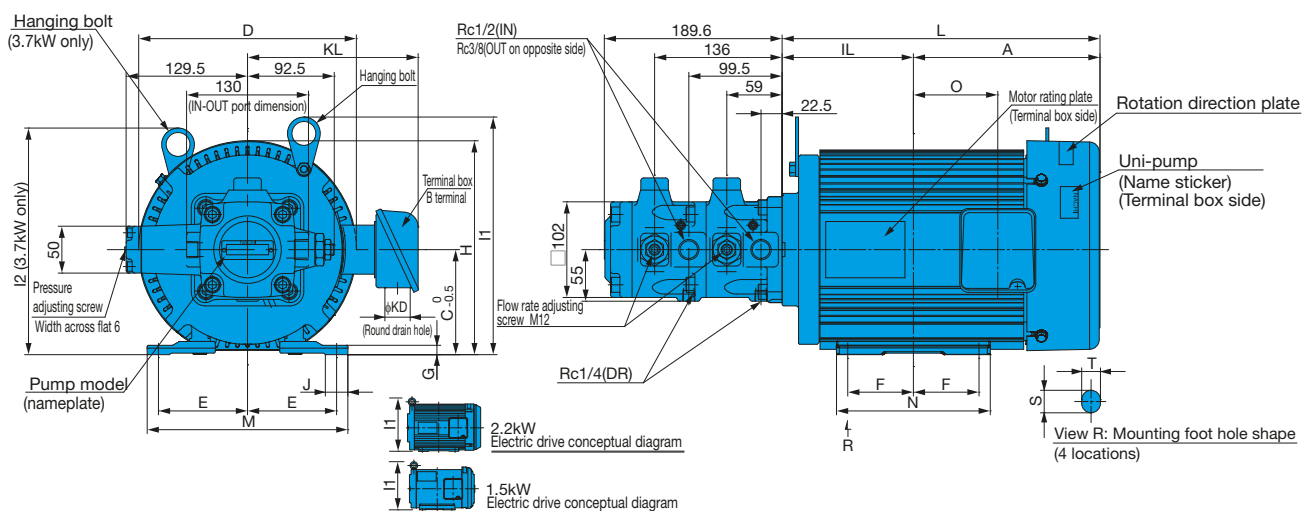

Uni-pump	Motor Dimensions [mm]																		Frame No.	Output kW (4 poles)	Weight kg	
	A	IL	C	D	E	F	G	H	I1	I2	J	L	M	N	SxT	φ KD	KL	O				
UVD-11A-A2-A2-1.5-4-60																						
UVD-11A-A2-A3-1.5-4-60	160.5	118.5	90	183	70	62.5	4.4	183	204	-	22	279	165	152.5	16x10	27	142	68	90L	1.5	39	
UVD-11A-A3-A3-1.5-4-60																						
UVD-11A-A2-A2-2.2-4-60																						
UVD-11A-A2-A3-2.2-4-60	179	133	100	206	80	70	7	203	226	-	39	312	206	170	14x12	27	153	83	100L	2.2	53	
UVD-11A-A3-A3-2.2-4-60																						
UVD-11A-2A2-2A2-2.2-4-60																						
UVD-11A-A2-A2-3.7-4-60																						
UVD-11A-A2-A3-3.7-4-60																						
UVD-11A-A3-A3-3.7-4-60	199	140	112	233	95	70	10	228	253	242	24	339	214	164	14x12	27	182	90	112M	3.7	57	
UVD-11A-2A2-2A2-3.7-4-60																						
UVD-11A-2A2-2A3-3.7-4-60																						

1. Standard drive motor is the fully enclosed fan-cooled F type.
2. Standard voltage for drive motor is 200 VAC, 50/60 Hz or 220 VAC, 60 Hz.
3. Standard terminal box is B terminal (right side viewed from pump).
4. See page A-21 for the characteristics of the drive motor for the unipump (domestic standard 3 rating).