



CONTENTS

Shock Absorber

Application	09
Production Process	10
Shock Absorber	12
Safety Instruction	14
Measuring and selection	17
IAAS Series Mini ranges	20
IASS Series	26
IAAH Series	32
IAAD Series	38
IASS Series Mid-Large ranges	44

Hydraulic Buffer

Measuring and selection	49
IBSG Series	51
IBAW Series	57
IBSW Series	61

Damper & Rate Control

ISAA Series	68
IDSMS Series	70
IDSP Series	72
IRAD Series	74
IASR Series	76



Best Engineered For Energy Absorption Technology





Overview

In many of industrial fields, production speed increased in high face for better productivity. In addition, the needs for high energy capacity with compact shock absorber has increased whereas the application product size is getting bigger.

Through intensive technical development, IZMAC upgrade all shock absorber models more than 200% capacity of previous ones and improve collision speed allowance range as 0.1m/sec~5 m/sec. Thanks to production management, IZMAC can provide low cost, long life products with short delivery time.

IZMAC would do its best to supply products that customer satisfy by way of ongoing research and development with advanced production & quality management.

Best Engineered For Energy Absorption Technology



DECELERATION CONTROL SOLUTION :

Provide customer deceleration control solution
customer satisfactory policy

CREATE MAX PRODUCTIVITY :

Create maximum productivity by supplying best
product to customers

INNOVATION :

On-going innovation to maintain its high level quality





Hydraulic Buffers

Military, Bridge, Crane & Trolley, Rail End Stop, Railway Coupler & Side Buffers, Elevator, Wind Turbine

Logistic Automation

Warehouse Automation, Mining, Conveyor Systems

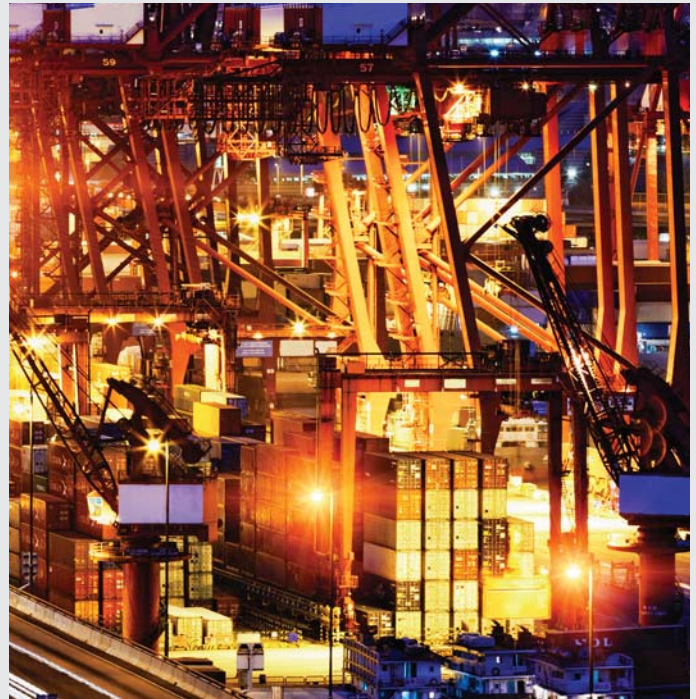

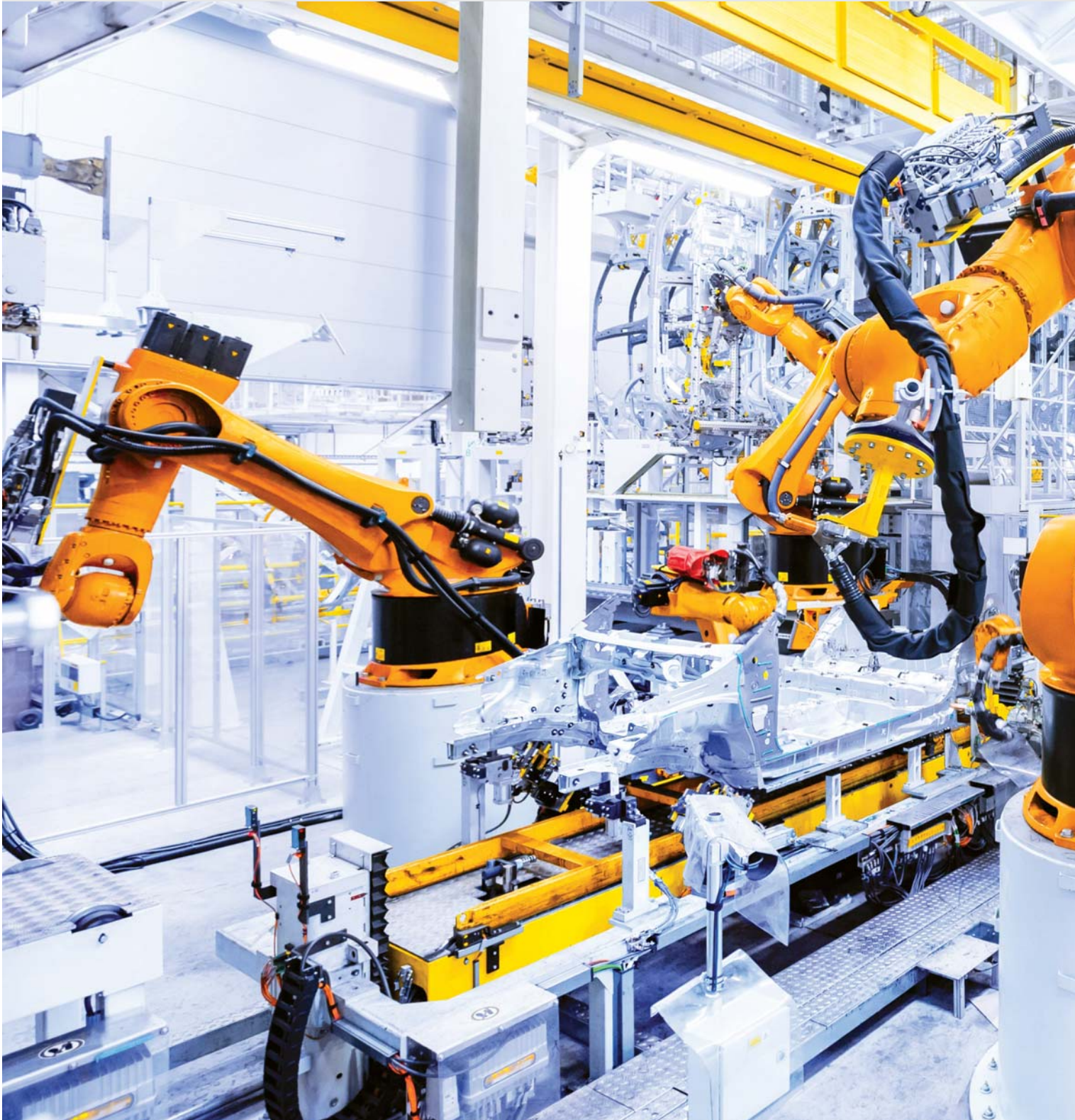
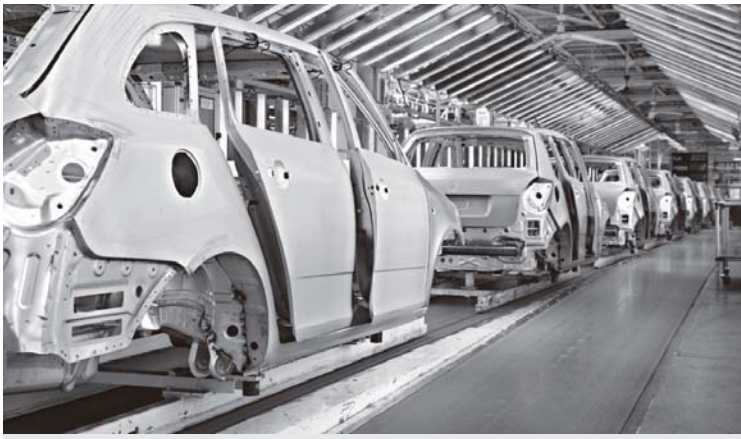



Applications

Factory Automation

Automotive

- Car manufacturing (Assembly/Transfer/ Inspection/Pick & Place robot line)
- Car-Welding, Assembly line, Tire line
- Electric actuator, Rodless cylinder, High speed cylinder, Guide cylinder, Stopper cylinder, Handling system, Linear module protection
- Pneumatic components
Grippers, Pneumatic cylinder, Pneumatic valve, Fluid control components
- Electronics
Semi-conductor equipment, Circuit breaker
- Factory
Steel factory, Paper factory
- Safety : Brake cylinder, Tie rod cylinder, Compact cylinder, Brake unit, Linear guide, Emergency stop



Features

- Upgrade precision degree
- Secure stability, Optimizing control
- Reliability of production lines
- Max productivity
- Decrease failure ratio
- Increase output quality level

Production Process

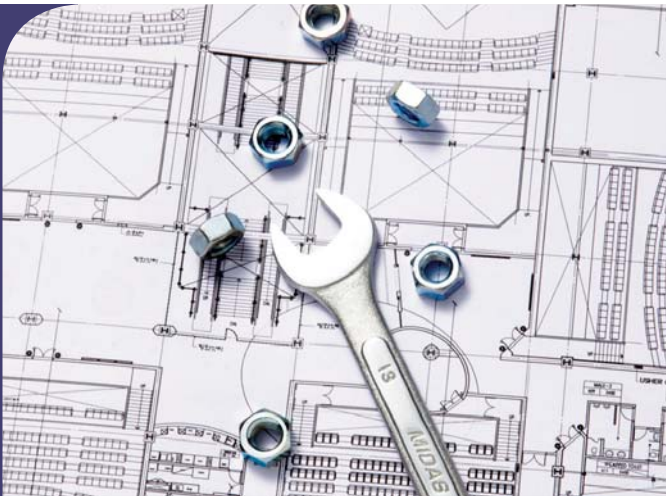

01

Design

What is technology? It will be the one which makes differences. IZMAC always open ears to hear customer's voices for renovation. IZMAC makes endless R&D and it supports to develop quality of products for customer's productivity. On time customizing is also one of helpful features of IZMAC.



02

Machining process

Clean machining clean products. IZMAC has its own fleets to doing machining process. To minimize defect ratio into "0", skillful engineers manage all over the process. Advanced machineries are helpful to carry out complicate & difficult output process.



03

Part inspection

IZMAC only supply products after total inspection process. If there are any small defects found it goes directly to the beginning process. Perfect product delivery is what IZMAC quality assurance system is aiming at.

04

Assembly

Assembly is one of very important process of production. Every part should be inserted into the right position to do its right function.



05

Product inspection / Test

Through product inspection In the final qualifying process, IZMAC products are ready to deliver customer's places. Defective products are automatically transferred to the beginning process of production or trashed to prevent quality trouble.



06

Shipping

IZMAC only supply products in perfect condition of packing. If there are any small defects found or manager feels that package is not settled well, the packaging system is reset for safe delivery. Perfect product delivery is what IZMAC quality assurance system is looking for.



Shock Absorber

Orifice features

SINGLE ORIFICE

- 1 Single orifice is called as "Dashpot" and it has only one orifice on the tube as a hole or circled shape gap. It has the features that orifice dimension is maintained for total stroke when it has flow activity.
- 2 As per the diagram, resistance force is going high suddenly after collision and it dramatically down when the stroke is in progress. And the force is decreasing step by step.

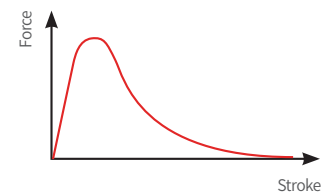
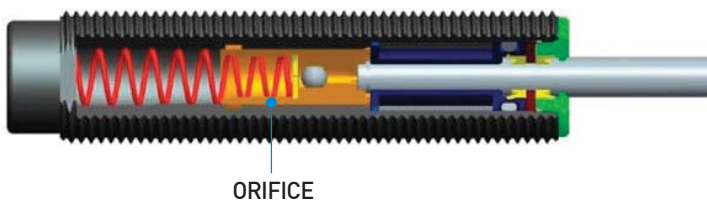

MULTIPLE ORIFICES

On the other hands, by using multiple orifices, total oil route dimension is decreasing when the stroke is on-going. It enables to maintain total shock absorption safely and softly.

■ Adjustable type

By using adjustment dial, it can provide best deceleration features against various collision cases.

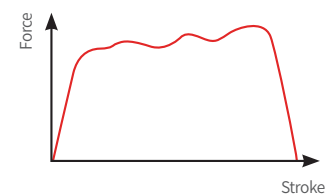
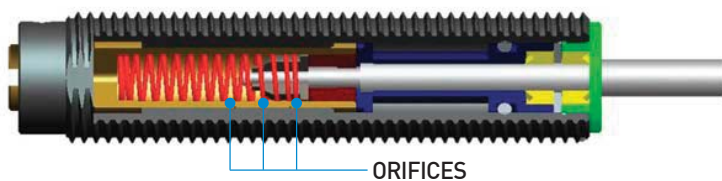

■ Self compensating

Self compensating type shock absorber is optimized for repeated work conditions and it makes ideal deceleration features by using highly optimized orifices on customized shock conditions.

Diagram A1 shows the condition of high speed/low propelling force, B1 shows low speed/high propelling forces and they show resist forces are not increased excessive manner on those contrast conditions.

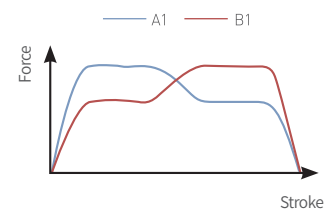
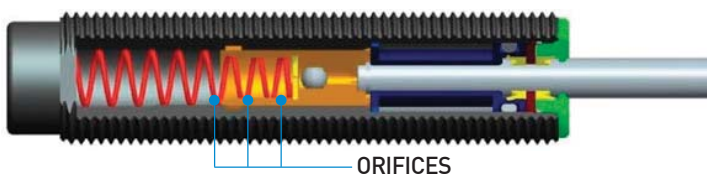

Principal of energy absorption

After impacting, piston is inserted into inner tube, oil flows through orifice holes made in the tube. The impact kinetic energy is changed into thermal energy by way of rebounding activity. And the thermal energy is dissipated outside through threaded body.



Internal Structure

- 1 Shock absorber is consist of 5 major parts : Head, Piston rod, Body, Adjustment dial and Lock nut.
- 2 Bumper head is the part which contact colliding object directly, and it has the function of stopper at the end of stroke with contacting body.
- 3 Piston rod transfer impact energy to the piston through full stroke.
- 4 Body outside is fully threaded for easy installation at any position and for more heat dissipation.
- 5 Adjustment dial is for optimum operation by setting Knob to the various impact conditions.
- 6 Lock nut is used for installing and fixing shock absorber tightly coupled with body thread on the machine.

Inside of shock absorber consist of piston, check valve, inner tube, multiple orifices, accumulator, return spring and oil. On impacting, the piston rod is inserted into inner tube and check valve is closed. And it forces oil in the chamber to flow through orifice. At the some time, damping force is generated into piston. Compressed oil which flowed into accumulator position is compensating same volume of piston inside. After one cycle ended, return process is made by coil spring and check valve is opened when it starts return process. Because the oil is moved from oil tube into inner tube, piston rod is returned to its original position for proper operation.

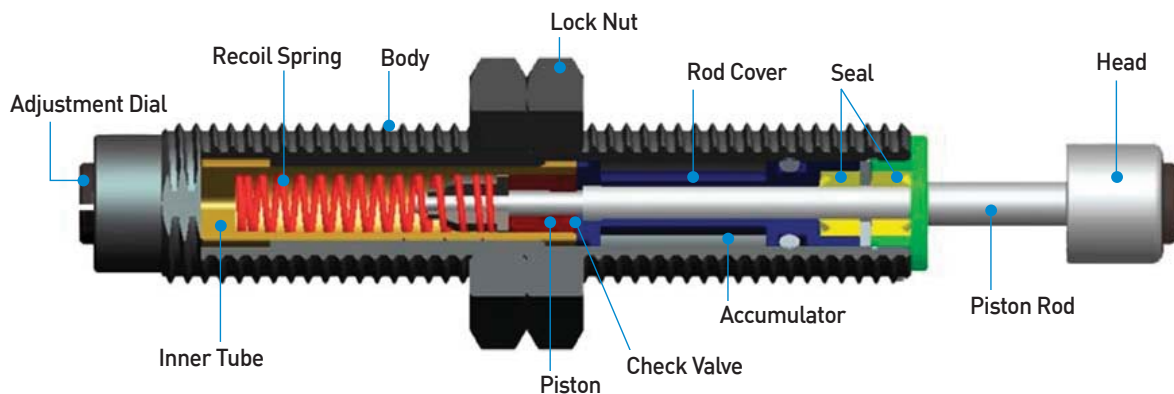

Ordering information

1 CODE		2 CODE		3 CODE		4 CODE	
Mark	Company	Mark	Product Name	Mark	Adjustable/Self Adjustable	Mark	Function / Application
I	IZMAC	A	Absorber	A	Adjustable	A	Absorption
		B	Buffer	S	Self compensating	C	Compression type
		D	Damper	O	Of[No meaning]	D	Double dial
		G	Gas spring	E	Extension	E	Expension type
		H	Hydro check			F	Free lock type
		R	Rate control			G	Gas type
		S	Speed control			H	Heavy type
						M	Multi step crash absorption
						O	Ordered design / Replacement
						P	Plastic made damping
				R	short Range absorption		
				S	Straight type		
				W	Warehouse stacker crane		
				T	Tension		

Safety Instruction

1. Shock absorber

IZMAC shock absorber has been developed up to million cycles. To assure long life cycle please be aware of the following regulations.

- 1-1 Ensure correct energy capacity before operation of shock absorber.
- 1-2 Do not paint or weld to the body of shock absorber.
- 1-3 Piston rod not to be marked or painted. (Shock absorber can fail by oil leakage.)
- 1-4 Adjustment dial knob is preset to "0" by factory. Once achieved the correct damping strength tighten the lock screw.
- 1-5 Be aware of to keep shock absorber away from fire due to filled up with oil there is a risk to ignite.
- 1-6 Always check strength of installation site before using and it recommended to install shock absorber at strong base structure.

Secure the strength as " Max shock energy x safety ratio. (2.5)"

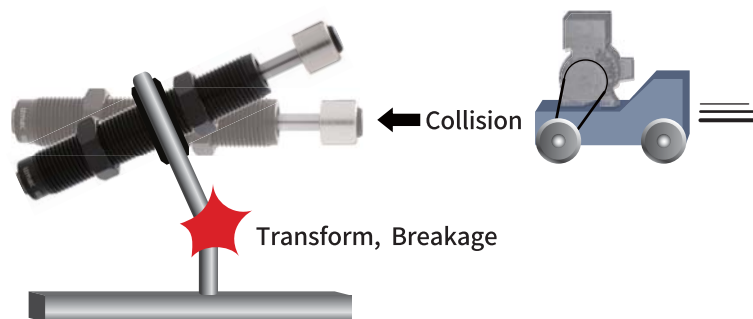

- 1-7 Refer to below table of proper lock nut installation tightening torque. Tightening with excessive force may cause malfunction or damage to product.

Screw outdia (mm)	M8x1.0	M10x1.0	M12x1.0	M14x1.0	M16x1.5	M20x1.5	M25x1.5	M27x1.5	M30x1.5	M36x1.5	M42x1.5
Nut Torque (Nm)	3.9	7.8	7.8	M14x1.5 9.8	14.7	29.4	49	M27x2.0 58.8	78.4	98	392

It will be efficient when it apply additional anti-loosening adhesives.

- 1-8 Always check the operation temperature of shock absorber to get best performance.





1-9 Impact mass should be perpendicular to the axis of shock absorber. In case of an side load impact especially angle of deviation over 1°, it is better to use an side load adapter. Otherwise failures can be occurred due to abrasion of inner sealings.



- 1-10 Shield the shock absorber to protect it from foreign material such as dust, acids, steam, solvents, cutting fluids, weld flash, and dust.
- 1-11 Check the operating temperature range of shock absorber (-10°C ~ 80°C) to get best performance. If you need to use shock absorber in other temperature exceed standard operating temperature, please contact us.
- 1-12 Adjustable type of shock absorber is designed to get suitable resistance force according to impact velocity by controlling the area of orifice. Refer to below adjustment dial of IAAS series, IAAD Series and IAAH Series.
Lock the set screw bolt after adjust dial with fitting properly on your application conditions.

IAAS & IAAD & IAAH Series Adjustment Dial

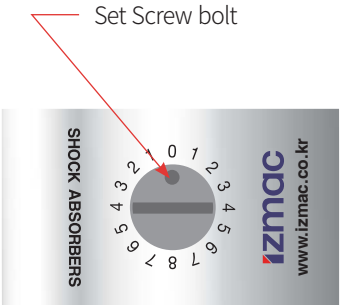
IAAS Series	IAAD Series	IAAH Series
 <p>Set Screw bolt</p>	 <p>Set Screw bolt</p>	 <p>Set Screw bolt</p>

It will be efficient when it apply additional anti-loosening adhesives.

2. General Inspection

2-1 Regular Checking

1) Check the below points regularly.

It is impossible to disassemble and repair the shock absorber so change the shock absorber when it is broken.

2) Inspection Point

- Condition of lock nut fastened
- Condition of piston rod (Damage or Scratch)
- Checking the stroke
- Outer appearance of shock absorber
- Oil leakage
- Noise on process

If any trouble found after inspection, please do trouble shooting with considering "2-2. trouble & trouble shooting.

2-2 Trouble and trouble - shooting

Trouble	Cause	Trouble - shooting
Lock Nut is not fastened tightly.	Lack of fixing torque	Fasten the nut or bolt tightly
	Vibration of machine	Check the vibration of machine and adjust it
Not Suitable Shock absorption	The required energy is over the capacity of shock absorber	Change the shock absorber with higher capacity
	The adjustable dial step is not suitable	Set adjustment dial to "0"
	Stop the stroke by stopper	Adjust the stopper location to use long stroke
	The shock absorber is not installed in line	Install the shock absorber in line
	The moving load is hit the shock absorber over 1 degree	
	There is vibration in moving load	Install the guide to remove the vibration
	Use the body of shock absorber as stopper	Install the stop collar or other stopper
	Ambient temperature is too high	Change the shock absorber which is applicable for high temperature
	Damaged seal by other material on the piston rod	Clean the piston rod and protect it from the dust
	The rotating moving load is impacted direct to shock absorber	Install the protection object to prevent from the direct impact to shock absorber
The lifespan of shock absorber is over	Change the shock absorber to new one	
OIL Leakage	Damaged seal by other material on the piston rod	Clean the piston rod and protect it from the dust
	Ambient temperature is too low	Warm the shock absorber as temp, over -10°C or change it to shock absorber for low temperature
	The lifespan of shock absorber is over	Change the shock absorber to new one
Rod is not returned.	The shock absorber is not installed in line	Install the shock absorber in line
	The moving load is hit the shock absorber over 1 degree	
	There is vibration in moving load	Install the guide to remove the vibration
	Use the body of shock absorber as stopper	Install the stop collar or other stopper
	Ambient temperature is too low	Warm the shock absorber as temp, over -10°C or change it to shock absorber for low temperature
	The lifespan of shock absorber is over	The lifespan of shock absorber is over

※ When using the shock absorber inside the chamber, be sure to contact IZMAC before using it.



■ Symbols

Symbol	Unit	Description	Symbol	Unit	Description
E_k	Nm	Kinetic energy	T	Nm	Torque
E_w	Nm	Work energy	H	m	Height
E_T	Nm	Total energy	m	kg	Weight
$E_T C$	Nm / h	Total energy per hour	P	bar	Operating pressure
F_s	N	Impact force	ω	rad / s	Angular velocity
F_p	N	Shock force	α	°	Angle of incline
m_e	kg	Effective weight	I	kgm ²	Moment of inertia
C	Cycles / h	Cycles per hour	K	m	Turning radius
S	m	Stroke	R_s	m	Mounting distance from pivot point
V	m / s	Impact velocity	μ		Coefficient of friction
V_D	m / s	Mass velocity	g	m / s ²	Gravitational acceleration
P_M	kW	Motor power	a	m / s ²	Acceleration
D	mm	Inner diameter of Cylinder	t	s	Time

■ Useful formulas

Description	Symbol	Formulas
Impact force	F_s	$= ET / S / 0.8$
Motor power	F_p	$= 3000 \times PM / V$
Cylinder power	F_p	$= 0.0785 \times D^2 \times P$
Effective weight	m_e	$= 2 \times ET / V^2$
Velocity (free falling)	V	$= \sqrt{2 \times g \times H}$
Velocity (with acceleration)	V	$= 2 \times D / t$
Velocity (w/o acceleration)	V	$= D / t$
Deceleration	a	$= V^2 / 2 / S$
Stopping time	t	$= 2.6 \times S / V$

■ Sizing examples

| A | Free falling mass

- Weight $m = 600\text{kg}$
- Height $H = 0.5\text{m}$
- Cycles per hour $C = 60\text{Cycles/h}$
- Gravitational acceleration $g = 9.81\text{m/s}^2$

$$E_k = m \times g \times H = 600 \times 9.81 \times 0.5 = 2,943 \text{ Nm}$$

Selected Model with E_k : IAAD64 -100

$$E_w = m \times g \times S = 600 \times 9.81 \times 0.1 = 589 \text{ Nm}$$

$$E_T = E_k + E_w = 2,943 + 589 = 3,532 \text{ Nm}$$

$$E_T C = E_T \times C = 3,532 \times 60 = 211,896 \text{ Nm / h}$$

$$V = \sqrt{2 \times g \times H} = \sqrt{2 \times 9.81 \times 0.5} = 3.13 \text{ m / s}$$

$$m_e = \frac{2 \times E_T}{V^2} = \frac{2 \times 3,532}{3.13^2} = 720 \text{ kg}$$

Selected Model with E_k , $E_T C$ & m_e : IAAD64-100

| B | Down mass with propelling force

- Weight $m = 1,200\text{kg}$
- Impact velocity $V = 1.8\text{m / s}$
- Inner diameter of Cylinder $D = 140\text{mm}$
- Operating pressure $P = 5\text{bar}$
- Cycles per hour $C = 125\text{Cycles / h}$

$$E_k = \frac{m \times V^2}{2} = \frac{1,200 \times 1.8^2}{2} = 1,944 \text{ Nm}$$

Selected Model with E_k : IAAD85-50

$$F_p = 0.0785 \times D^2 \times P + W \times g = 0.0785 \times 140^2 \times 5 + 1,200 \times 9.81 = 19,465 \text{ N}$$

$$E_w = F_p \times S = 19,465 \times 0.05 = 973 \text{ Nm}$$

$$E_T = E_k + E_w = 1,944 + 973 = 2,917 \text{ Nm}$$

$$E_T C = E_T \times C = 2,917 \times 125 = 364,656 \text{ Nm / h}$$

$$m_e = \frac{2 \times E_T}{V^2} = \frac{2 \times 2,917}{1.8^2} = 1,801 \text{ kg}$$

Selected Model with E_k , $E_T C$ & m_e : IAAD85-50

C | Up mass with propelling force

- Weight $m = 200\text{kg}$
- Impact velocity $V = 2.5\text{m/s}$
- Inner diameter of Cylinder $D = 150\text{mm}$
- Operating pressure $P = 5\text{bar}$
- Cycles per hour $C = 180\text{Cycles/h}$

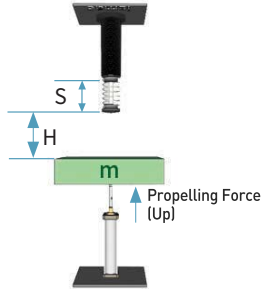

$$E_k = \frac{m \times V^2}{2} = \frac{200 \times 2.5^2}{2} = 625 \text{ Nm}$$

Selected Model with E_k : IAAD45-50

$$F_p = 0.0785 \times D^2 \times P + m \times g =$$

$$0.0785 \times 150^2 \times 5 - 200 \times 9.81 = 6,869 \text{ N}$$

$$E_w = F_p \times S = 6,869 \times 0.05 = 343 \text{ Nm}$$

$$E_T = E_k + E_w = 625 + 343 = 968 \text{ Nm}$$

$$E_T C = E_T \times C = 968 \times 180 = 174,323 \text{ Nm / h}$$

$$m_e = \frac{2 \times E_T}{V^2} = \frac{2 \times 968}{2.5^2} = 310 \text{ kg}$$

Selected Model with E_k , $E_T C$ & m_e : IAAD45-50

D | Horizontal mass without propelling force

- Weight $m = 100\text{kg}$
- Impact velocity $V = 1.5\text{m/s}$
- Cycles per hour $C = 600\text{Cycles/h}$

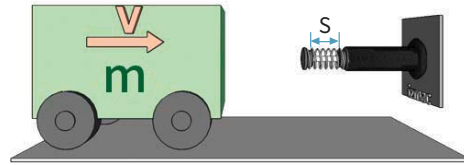

$$E_k = \frac{m \times V^2}{2} = \frac{100 \times 1.5^2}{2} = 113 \text{ Nm}$$

$$E_T = E_k + E_w = 113 + 0 = 113 \text{ Nm}$$

$$E_T C = E_T \times C = 113 \times 600 = 67,800 \text{ Nm / h}$$

$$m_e = \frac{2 \times E_T}{V^2} = \frac{2 \times 113}{1.5^2} = 100 \text{ kg}$$

Selected Model with E_k , $E_T C$ & m_e : IAAS25-25

E | Horizontal mass with propelling force [Cylinder]

- Weight $m = 300\text{kg}$
- Impact velocity $V = 1.2\text{m/s}$
- Inner diameter of Cylinder $D = 50\text{mm}$
- Operating pressure $P = 5\text{bar}$
- Cycles per hour $C = 300\text{Cycles/h}$

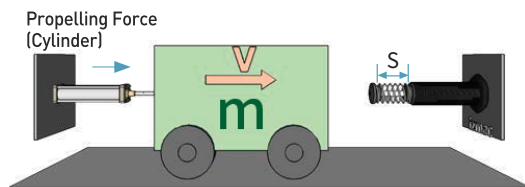

$$E_k = \frac{m \times V^2}{2} = \frac{300 \times 1.2^2}{2} = 216 \text{ Nm}$$

Selected Model with E_k : IAAS36-25

$$F_p = 0.0785 \times D^2 \times P = 0.0785 \times 50^2 \times 5 = 981 \text{ N}$$

$$E_w = F_p \times S = 981 \times 0.025 = 25 \text{ Nm}$$

$$E_T = E_k + E_w = 216 + 25 = 241 \text{ Nm}$$

$$E_T C = E_T \times C = 241 \times 300 = 72,300 \text{ Nm / h}$$

$$m_e = \frac{2 \times E_T}{V^2} = \frac{2 \times 241}{1.2^2} = 334 \text{ kg}$$

Selected Model with E_k , $E_T C$ & m_e : IAAS36-25

F | Horizontal mass with propelling force [Motor]

- Weight $m = 1,300\text{kg}$
- Impact velocity $V = 1.6\text{m/s}$
- Motor power $P = 3\text{kW}$
- Cycles per hour $C = 100\text{Cycles/h}$

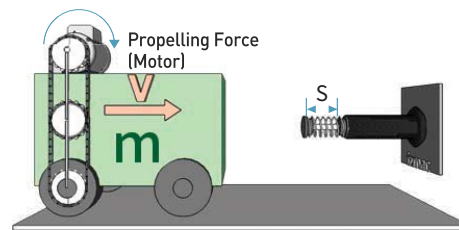

$$E_k = \frac{m \times V^2}{2} = \frac{1,300 \times 1.6^2}{2} = 1,664 \text{ Nm}$$

Selected Model with E_k : IAAD64-50

$$F_p = \frac{3,000 \times P_M}{V} = \frac{3,000 \times 3}{1.6} = 5,625 \text{ N}$$

$$E_w = F_p \times S = 5,625 \times 0.05 = 281 \text{ Nm}$$

$$E_T = E_k + E_w = 1,664 + 281 = 1,945 \text{ Nm}$$

$$E_T C = E_T \times C = 1,945 \times 100 = 194,500 \text{ Nm / h}$$

$$m_e = \frac{2 \times E_T}{V^2} = \frac{2 \times 1,945}{1.6^2} = 1,520 \text{ kg}$$

Selected Model with E_k , $E_T C$ & m_e : IAAD64-50



G | Sliding down mass without propelling force

- Weight $m = 800\text{kg}$
- Height $H = 0.7\text{m}$
- Angle of incline $\alpha = 30^\circ$
- Cycles per hour $C = 100\text{Cycles/h}$

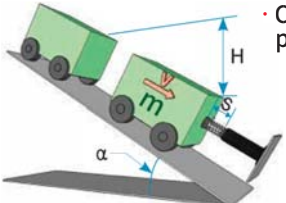

$E_k = m \times g \times H = 800 \times 0.7 \times 9.81 = 5,494 \text{ Nm}$
 Selected Model with E_k : IAAD85-100
 $F_p = m \times \sin(\alpha) \times g = 800 \times \sin(30) \times 9.81 = 3,922 \text{ N}$
 $E_w = F_p \times S = 3,922 \times 0.1 = 392 \text{ Nm}$
 $E_T = E_k + E_w = 5,494 + 392 = 5,886 \text{ Nm}$
 $E_{TC} = E_T \times C = 5,886 \times 100 = 588,600 \text{ Nm}$
 $V = \sqrt{2 \times g \times H} = \sqrt{2 \times 9.81 \times 0.7} = 3.7 \text{ m/s}$
 $m_e = \frac{2 \times E_T}{V^2} = \frac{2 \times 5,886}{3.7^2} = 857 \text{ Nm/h}$
 Selected Model with E_k , E_{TC} & m_e : IAAD85-100

H | Rotary table mass with propelling force

- Weight $m = 200\text{kg}$
- Angle of incline $\omega = 2\text{rad/s}$
- Mounting distance form pivot point $R_s = 0.5\text{m}$
- Radius of gyration $K = 0.8\text{m}$
- Torque $T = 400\text{Nm}$
- Cycles per hour $C = 350\text{Cycles/h}$

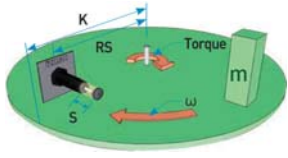

$I = m \times K^2 = 200 \times 0.8^2 = 128 \text{ kgm}^2$
 $E_k = \frac{I \times \omega^2}{2} = \frac{128 \times 2^2}{2} = 256 \text{ Nm}$
 Selected Model with E_k : IAAS36-25
 $F_p = \frac{T}{R_s} = \frac{400}{0.5} = 800 \text{ N}$
 $E_w = F_p \times S = 800 \times 0.025 = 20 \text{ Nm}$
 $E_T = E_k + E_w = 256 + 20 = 276 \text{ Nm}$
 $E_{TC} = E_T \times C = 276 \times 350 = 96,600 \text{ Nm/h}$
 $V = R_s \times \omega = 0.5 \times 2 = 1 \text{ m/s}$
 $E_k = \frac{2 \times E_T}{V^2} = \frac{2 \times 276}{1^2} = 552 \text{ kg}$
 Selected Model with E_k , E_{TC} & m_e : IAAS36-25

I | Swiveling mass with propelling force

- Weight $m = 50\text{kg}$
- Angle of incline $\omega = 2.5\text{rad/s}$
- Mounting distance form pivot point $R_s = 0.8\text{m}$
- Radius of gyration $K = 0.5\text{m}$
- Inner diameter of Cylinder $D = 40\text{mm}$
- Operating pressure $P = 5\text{Bar}$
- Cycles per hour $C = 1,000\text{Cycles/h}$

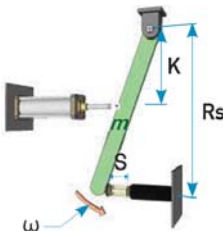

$I = m \times K^2 = 250 \times 0.5^2 = 13 \text{ kgm}^2$
 $E_k = \frac{I \times \omega^2}{2} = \frac{13 \times 2.5^2}{2} = 39 \text{ Nm}$
 Selected Model with E_k : IAAS20-15
 $F_p = \frac{0.0785 \times D^2 \times P \times K}{R_s} = \frac{0.0785 \times 40^2 \times 5 \times 0.5}{R_s} = 393 \text{ N}$
 $T = F_p \times R_s = 393 \times 0.8 = 314 \text{ Nm}$
 $E_w = F_p \times S = 393 \times 0.015 = 6 \text{ Nm}$
 $E_T = E_k + E_w = 39 + 6 = 45 \text{ Nm}$
 $E_{TC} = E_T \times C = 45 \times 1,000 = 45,000 \text{ Nm/h}$
 $V = R_s \times \omega = 2.5 \times 0.8 = 2 \text{ m/s}$
 $E_k = \frac{2 \times E_T}{V^2} = \frac{2 \times 45}{2^2} = 22 \text{ kg}$
 Selected Model with E_k , E_{TC} & m_e : IAAS20-15

J | Swiveling mass without propelling force

- Weight $m = 200\text{kg}$
- Impact velocity $V = 2\text{m/s}$
- Angle of incline $\omega = 2.5\text{rad/s}$
- Mounting distance form pivot point $R_s = 0.6\text{m}$
- Radius of gyration $K = 0.8\text{m}$
- Cycles per hour $C = 200\text{Cycles/h}$

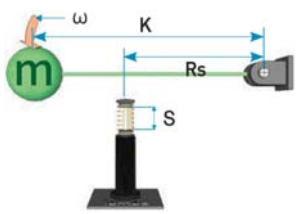

$I = m \times K^2 = 200 \times 0.8^2 = 128 \text{ kgm}^2$
 $E_k = \frac{I \times \omega^2}{2} = \frac{128 \times 2.5^2}{2} = 400 \text{ Nm}$
 Selected Model with E_k : IAAS36-50
 $F_p = \frac{m \times g \times K}{R_s} = \frac{200 \times 9.81 \times 0.8}{0.6} = 2,616 \text{ N}$
 $E_w = F_p \times S = 2,616 \times 0.05 = 131 \text{ Nm}$
 $E_T = E_k + E_w = 400 + 131 = 531 \text{ Nm}$
 $E_{TC} = E_T \times C = 531 \times 200 = 106,200 \text{ Nm/h}$
 $V_D = \frac{V \times R_s}{K} = \frac{2 \times 0.6}{0.8} = 1.5 \text{ m/s}$
 $m_e = \frac{2 \times E_T}{V_D^2} = \frac{2 \times 531}{1.5^2} = 472 \text{ kg}$
 Selected Model with E_k , E_{TC} & m_e : IAAS36-50

IAAS Series Dial type

Izmac Absorber Adjustable Straight type, Mini ranges

DESCRIPTION

IAAS has dial which can set 12 steps of shock speed ranges and it improved by wider damping ranges. Improved energy capacity over 200% and effective weight ranges become wider than before.

IAAS series

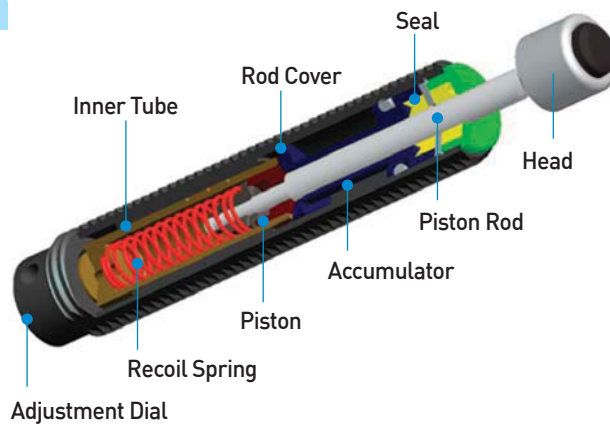

FEATURES

- 1 All threaded body outside helps to install shock absorber and it can be fixed exact position. And it helps also to dissipate more shock energy by increased surface dimension.
- 2 Body surface treated as alloyed black colored steel or Zn-Ni and it develop anti corrosion features highly.
- 3 Stop collar is not necessary when shock absorber has steel head, and poly pad & urethane cap will helps to decrease collision noises efficiently.
- 4 Rod cover is made of long lasting materials with function of seal protection and that enable to guarantee long life.
- 5 Speed ranges standard : 0.1 ~ 5m/s • Low Velocity (LV) : Option
- 6 Temperature ranges standard : -10 ~ 80°C • Special : -40 ~ 120°C

APPLICATIONS

Pick N place robot, machining tools, automobile assembly line, tire assembly line, crane, safety devices and all other industrial ranges of multi purposes.

IAAS SERIES ORDERING INFORMATION

IAAS - 25 - 25 - SC

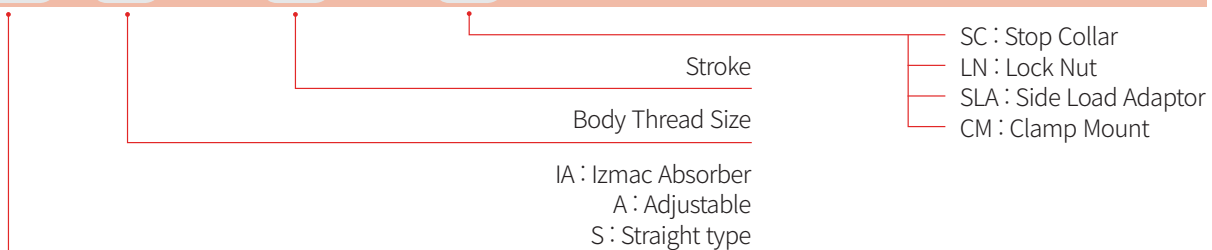

IAAS10 - 07(B) / 12 - 10(B)

Best engineered
for energy absorption
technology

Engineering Data

Model	Stroke (mm)	Max. Energy / Cycle (Nm) E_T	Max. Energy / Hour (Nm/h) $E_T C$	Effective Weight (kg) m_e	Recoil Fore (N)		Weight (g)
					Ext.	Comp.	
IAAS10 - 07(B)	7	5.5	15,000	1 - 123	2.4	5.4	21
IAAS12 - 10(B)	10	16	30,500	1.5 - 333	3.6	9.8	41

Dimensions

Model	Stroke	A	B	C	D	E	F	G	H	M	Dr
IAAS10 - 07(B)	7	68	1.2	52.8	7	61	Ø8.6	8.6	SW:8.8	M10X1.0	Ø3
IAAS12 - 10(B)	10	84	1.2	62.8	10	74	Ø10.5	Ø10.5	-	M12X1.0	Ø4

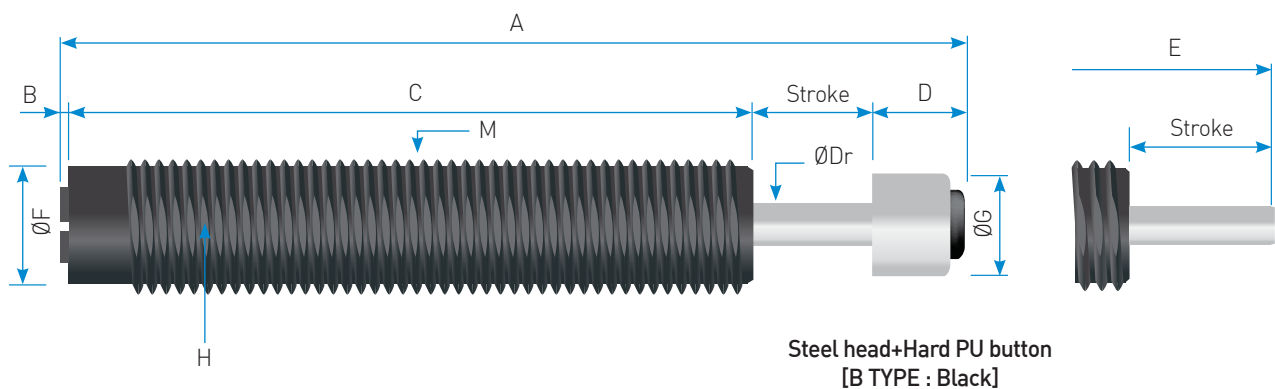

Accessories

Model	Stop Collar				Side Load Adapter					Clamp Mount						Lock Nut		
	A1	A2	A3	A4	B1	B2	B3	B4	B5	C1	C2	C3	C4	C5	C6	D1	D2	D3
IAAS10 - 07(B)	20	8	Ø12.8	M10 X 1.0	12	12.5	7	M10 X 1.0	Ø4	16	14	25	10	M10 X 1.0	M4	13	M10 X 1.0	4
IAAS12 - 10(B)	20	8	Ø13.8	M12 X 1.0	12	17.5	10	M12 X 1.0	Ø5	20	16	32	12	M12 X 1.0	M5 X 18L	14	M12 X 1.0	4

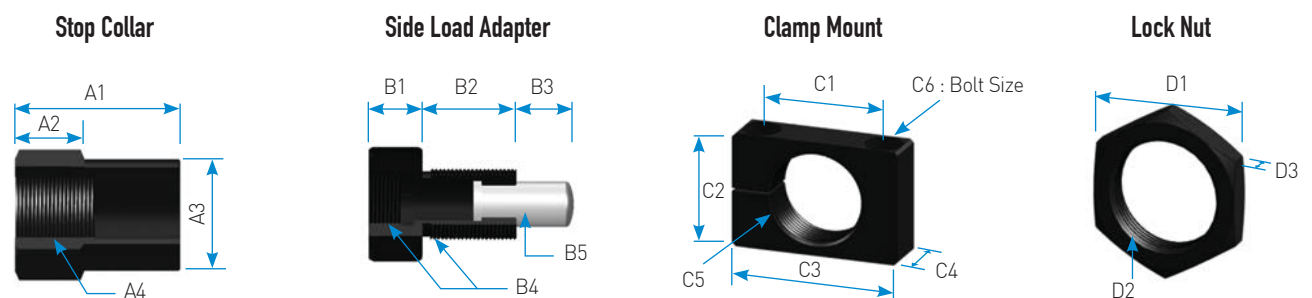

IAAS14 - 12(B) / 16 - 12(B)

Engineering Data

Model	Stroke (mm)	Max.Energy / Cycle(Nm)	Max.Energy / Hour (Nm / h)	Effective Weight(kg)	Recoil Forec(N)		Weight(g)
					Ext.	Comp.	
IAAS14 - 12(B)	12	18	38,000	1.8 - 400	4.9	11.4	60
IAAS16 - 12(B)	12	24	47,200	2-530	5	11.5	84

Dimensions

Model	Stroke	A	B	C	D	E	F	G	H	M	Dr
IAAS14 - 12(B)	12	96	1.2	72.8	10	86	Ø12	Ø10.5	SW:12.5	M14X1.5	Ø4
IAAS16 - 12(B)	12	97	1.2	71.3	12.5	84.5	Ø10.5	Ø13.6	SW:14.5	M16X1.5	Ø5

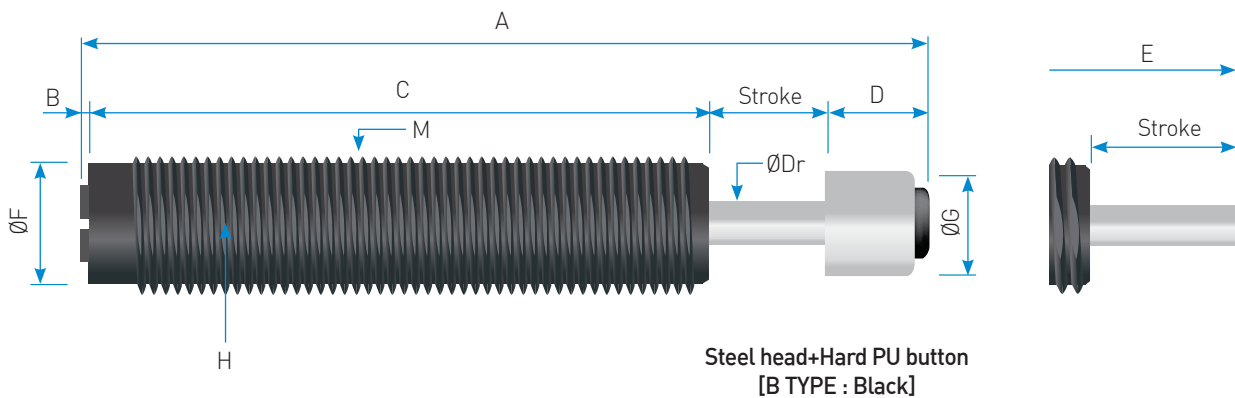

Accessories

Model	Stop Collar				Side Load Adapter					Clamp Mount						Lock Nut		
	A1	A2	A3	A4	B1	B2	B3	B4	B5	C1	C2	C3	C4	C5	C6	D1	D2	D3
IAAS14 - 12(B)	27	12	Ø18	M14 X 1.5	14	19.5	12	M14 X 1.5	Ø6	20	20	32	12	M14 X 1.5	M5 X 25L	19	M14 X 1.5	5
IAAS16 - 12(B)	27	12	Ø19	M16 X 1.5	19	22.8	12	M16 X 1.5	Ø8	24	22	36	16	M16 X 1.5	M6 X 25L	19	M16 X 1.5	6

Stop Collar

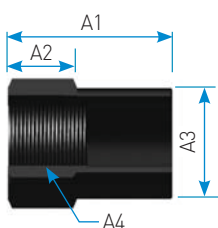

Side Load Adapter

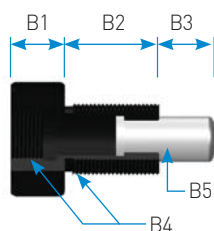

Clamp Mount

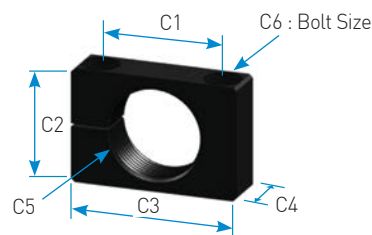

Lock Nut

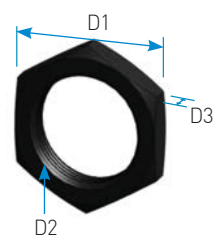

IAAS20 - 15(B) / 25 - 25(B)

Best engineered
for energy absorption
technology

Engineering Data

Model	Stroke (mm)	Max. Energy / Cycle(Nm)	Max. Energy / Hour (Nm / h)	Effective Weight(kg)	Recoil Forec(N)		Weight(g)
					Ext.	Comp.	
IAAS20 - 15(B)	15	56	58,000	4.5-1,240	8	19,6	139
IAAS25 - 25(B)	25	150	96,000	11.5-3,330	10.2	29.5	285

Dimensions

Model	Stroke	A	B	C	D	E	F	G	H	M	Dr
IAAS20 - 15(B)	15	109	1.5	79	13.5	95.5	Ø17.6	Ø13.5	SW:18.5	M20X1.5	Ø6
IAAS25 - 25(B)	25	144	1.5	101	16.5	127.5	Ø22.6	Ø16	SW:23	M25X1.5	Ø8

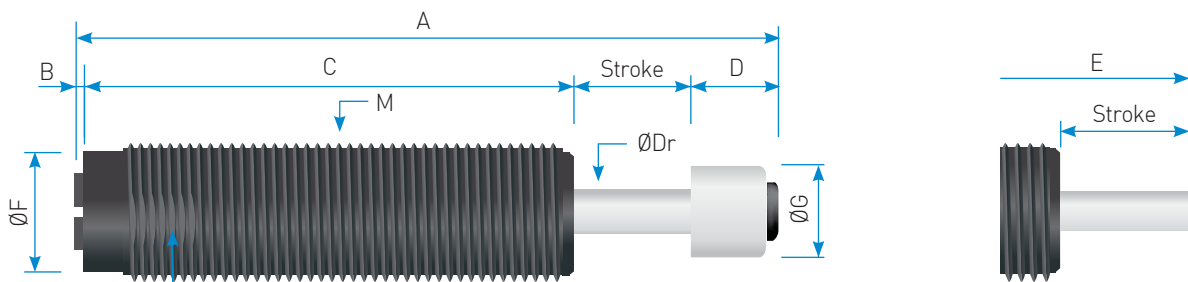

Steel head+Hard PU button
[B TYPE : Black]

Accessories

Model	Stop Collar				Side Load Adapter					Clamp Mount						Lock Nut		
	A1	A2	A3	A4	B1	B2	B3	B4	B5	C1	C2	C3	C4	C5	C6	D1	D2	D3
IAAS20 - 15(B)	36	15	Ø24	M20 X 1.5	20	34	15	M20 X 1.5	Ø12	28	25	40	20	M20 X 1.5	M6 X 30L	24	M20 X 1.5	6
IAAS25 - 25(B)	42	18	Ø31.5	M25 X 1.5	20	42	25	M25 X 1.5	Ø16	32	32	46	25	M25 X 1.5	M6 X 35L	32	M25 X 1.5	8

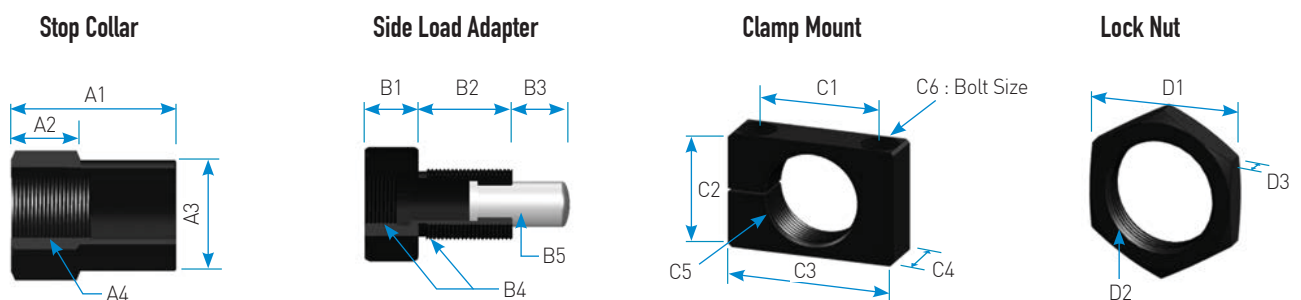

IAAS27 - 25(B) / 27 - 25F(B)

Engineering Data

Model	Stroke (mm)	Max.Energy / Cycle(Nm)	Max.Energy / Hour (Nm / h)	Effective Weight(kg)	Recoil Forec(N)		Weight(g)
					Ext.	Comp.	
IAAS27 - 25(B)	25	150	96,000	11.5-3,330	10.2	29.5	303
- 25F(B)							325

Dimensions

Model	Stroke	A	B	C	D	E	F	G	H	M	Dr
IAAS27 - 25(B)	25	144	1.5	101	16.5	127.5	Ø22.6	Ø16	SW:25(23)	M27X3.0	Ø8
- 25F(B)									SW:25	M27X1.5	

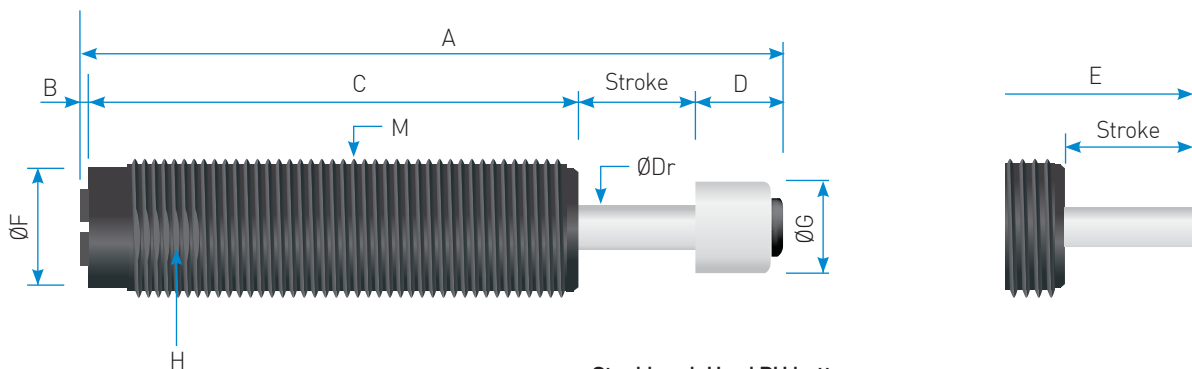

Steel head+Hard PU button
[B TYPE : Black]

Accessories

Model	Stop Collar				Side Load Adapter					Clamp Mount						Lock Nut		
	A1	A2	A3	A4	B1	B2	B3	B4	B5	C1	C2	C3	C4	C5	C6	D1	D2	D3
IAAS27 - 25(B)	42	18	Ø31.5	M27 X 3.0	20	42	25	M27 X 3.0	Ø16	35	32	48	25	M27 X 3.0	M6 X 35L	32	M27 X 3.0	8
- 25F(B)				M27 X 1.5				M27 X 1.5						M27 X 1.5				

Stop Collar

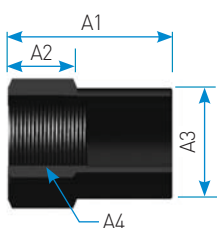

Side Load Adapter

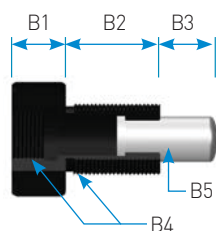

Clamp Mount

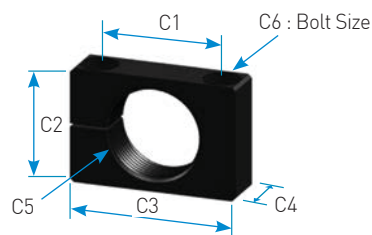

Lock Nut

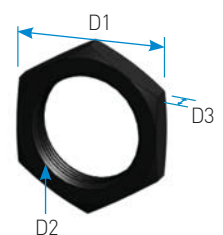

IAAS36 - 25(B) / 36 - 50 (B)

Best engineered
for energy absorption
technology

Engineering Data

Model	Stroke (mm)	Max.Energy / Cycle(Nm)	Max.Energy / Hour (Nm / h)	Effective Weight(kg)	Recoil Forec(N)		Weight(g)
					Ext.	Comp.	
IAAS36 - 25(B)	25	300	108,000	24 - 6,667	25	56.2	700
- 50(B)	50	615	142,000	49 - 13,667	22.5	60	811

Dimensions

Model	Stroke	A	B	C	D	E	F	G	H	M	Dr
IAAS36 - 25(B)	25	158.5	2	116	15.5	143	Ø31	Ø28	SW:34	M36 X 1.5	Ø10
- 50(B)	50	218	2	150.5	15.5	202.5	Ø31	Ø28	SW:34	M36 X 1.5	Ø10

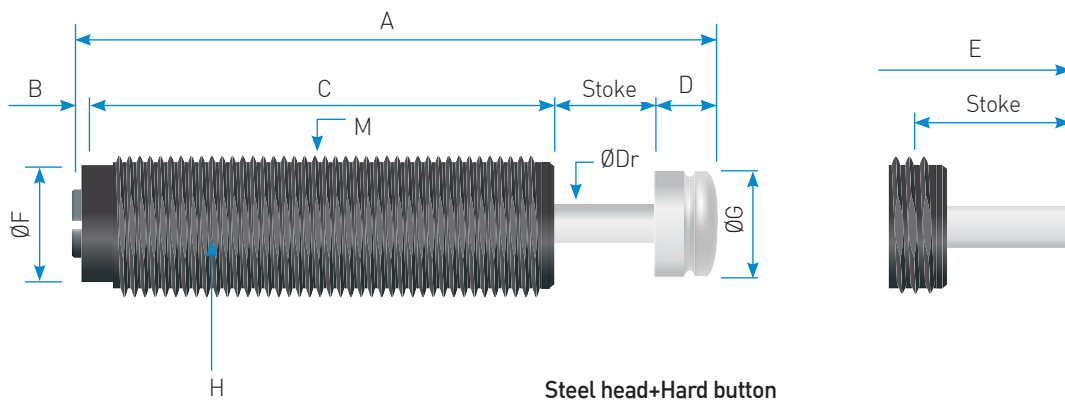

Accessories

Model	StopCollar				Side Load Adapter					Clamp Mount						Lock Nut		
	A1	A2	A3	A4	B1	B2	B3	B4	B5	C1	C2	C3	C4	C5	C6	D1	D2	D3
IAAS36 - 25(B)	62	26	Ø45	M36 X 1.5	22	47	25	M36 X 1.5	20	45	42	61	25	M36 X 1.5	M6 X 45L	46	M36 X 1.5	10
- 50(B)					22	78	50											

Stop Collar

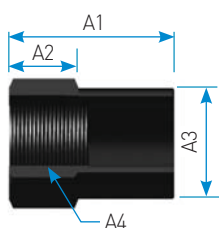

Side Load Adapter

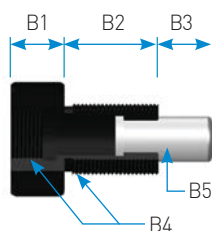

Clamp Mount

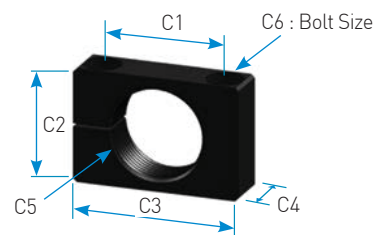

Lock Nut

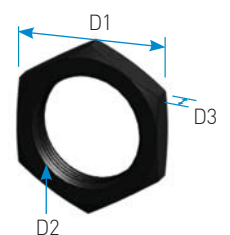

IASS Series Self Compensating type

Izmac Absorber Self compensating Straight type

DESCRIPTION

IASS is self compensating type and it control the damping power itself against damping speed. Improved energy capacity over 200% and effective weight ranges become wider than before.

IASS series

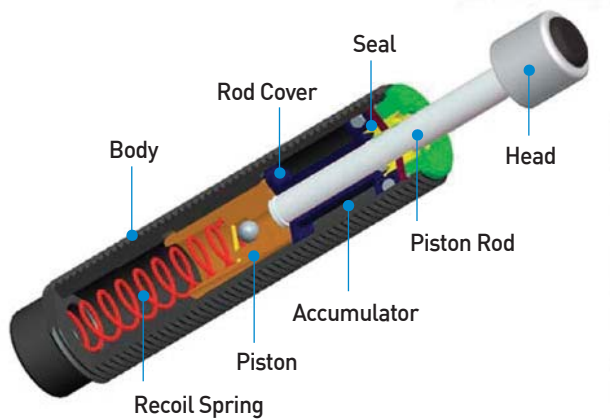

FEATURES

- 1 All threaded body outside helps to install shock absorber and it can be fixed exact position. And it helps also to dissipate more shock energy by increased surface dimension.
- 2 Body surface treated as alloyed black colored steel or Zn-Ni and it develop anti corrosion features highly.
- 3 Stop collar is not necessary when shock absorber has steel head, and poly pad & urethane cap will helps to decrease collision noises efficiently.
- 4 Rod cover is made of long lasting materials with function of seal protection and that enable to guarantee long life.
- 5 Speed ranges standard : 0.1 ~ 5m/s • Low Velocity (LV) : Option
- 6 Temperature ranges standard : -10 ~ 80°C • Special : -40 ~ 120°C

APPLICATIONS

Pick N place robotic line, machining tools, automobile assembly line, tire assembly line, crane, safety devices and all other industrial ranges of multi purposes.

IASS SERIES ORDERING INFORMATION

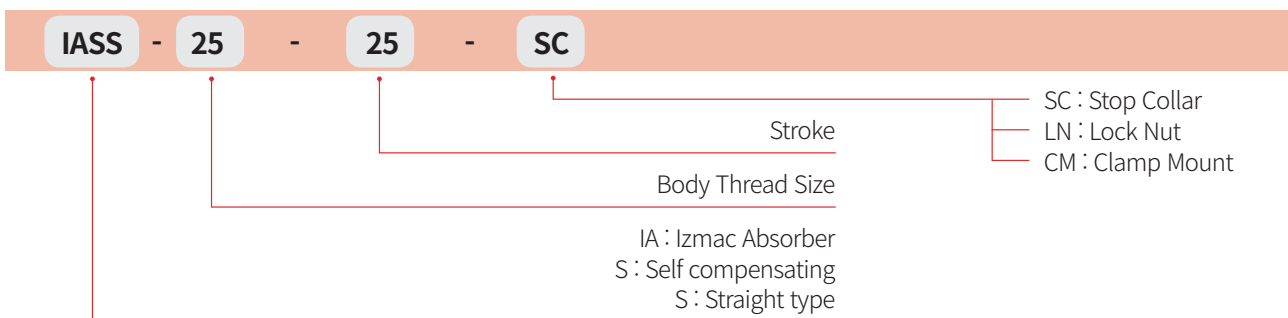

IASS04 - 04(B) / 05 - 05(B) / 06 - 05(B)

Best engineered
for energy absorption
technology



Engineering Data

Model	Stroke (mm)	Max. Energy / Cycle (Nm)	Max. Energy / Hour (Nm / h)	Effective Weight (Kg)			Recoil Force (N)		Weight (g)
				S	M	H	Ext.	Comp.	
IASS04 - 04(B)	4	0.4	1,500	0.1 - 1.0	0.9 - 3.2		2	7	2.5
IASS05 - 05(B)	5	0.6	1,800	0.1 - 1.2	1.0 - 5.0		2	7	2.5
IASS06 - 05(B)	5	1	2,500	0.05 - 1	0.8 - 2.8	1.5 - 4	2	5	4.0

Dimensions

(unit : mm)

Model	Stroke	A	B	C	D	E	F	G	M	Dr
IASS04 - 04(B)	4	34.5	2.4	24	4	30.5	3.4	Ø3	M4 X 0.5	Ø1.2
IASS05 - 05(B)	5	35	3.5	22.5	4	31	4.4	Ø3	M5 X 0.5	Ø1.5
IASS06 - 05(B)	5	38.5	3.5	25	5	33.5	5.3	Ø5	M6 X 0.5	Ø1.5

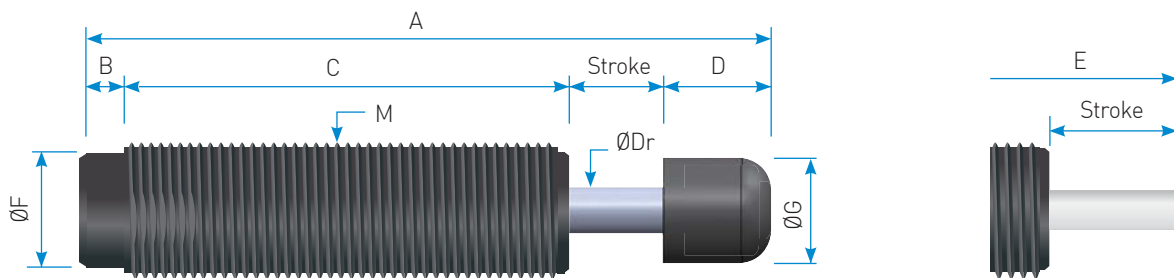

MC Nylon head

Accessories

(unit : mm)

Model	Stop Collar			Clamp Mount						Lock Nut		
	A1	A2	A3	C1	C2	C3	C4	C5	C6	D1	D2	D3
IASS04 - 04(B)			M4 X 0.5							8	5	M4 X 0.5
IASS05 - 05(B)	10	7	M5 X 0.5	12	10	20	8	M5 X 0.5	M3	8	5	M5 X 0.5
IASS06 - 05(B)	12	8	M6 X 0.5	12	10	20	8	M6 X 0.5	M3	8	5	M6 X 0.5

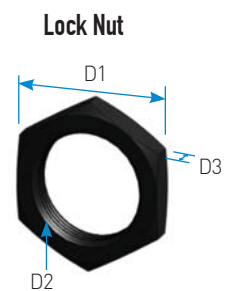
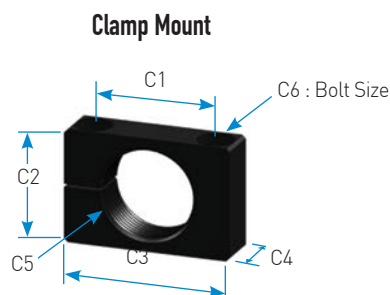
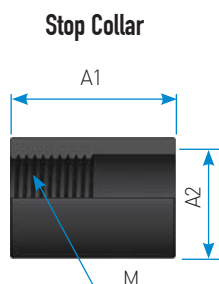

IASS08 - 06(B) / 10 - 08(B)

Engineering Data

Model	Stroke (mm)	Max.Energy / Cycle(Nm)	Max.Energy / Hour (Nm / h)	Effective Weight(Kg)			Recoil Force(N)		Weight(g)
				S	M	H	Ext.	Comp.	
IASS08 - 06(B)	6	5	8,000	0.8 - 2.8	2.5 - 12.6	10 - 111	2.2	5.8	10
IASS10 - 08(B)	8	11	14,500	1.8 - 6.1	5.5 - 27	22 - 244	2.5	6.9	15.5

Dimensions

(unit : mm)

Model	Stroke	A	B	C	D	E	F	G	M	Dr
IASS08 - 06(B)	6	54	7.5	35	7	47	Ø6.8	Ø6.8	M8 X 1.0	Ø2
IASS10 - 08(B)	8	64.5	7.5	42	7	57.5	Ø7	Ø8	M10 X 1.0	Ø3

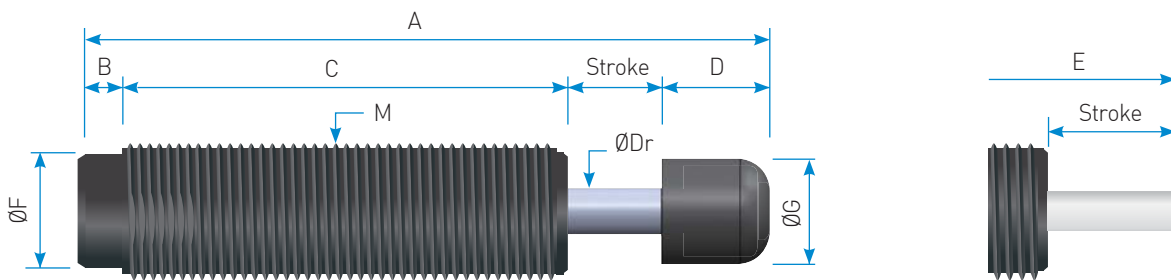

MC Nylon head

Accessories

(unit : mm)

Model	Stop Collar				Clamp Mount						Lock Nut		
	A1	A2	A3	A4	C1	C2	C3	C4	C5	C6	D1	D2	D3
IASS08 - 06(B)	20	8	Ø11.5	M8 X 1.0	16	14	25	10	M8 X 1.0	M4 X 16L	12	M8 X 1.0	3
IASS10 - 08(B)	20	8	Ø12.8	M10 X 1.0	16	14	25	10	M10 X 1.0	M4 X 16L	13	M10 X 1.0	4

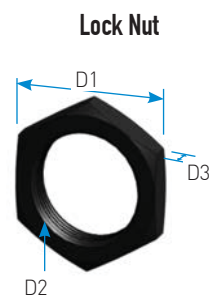
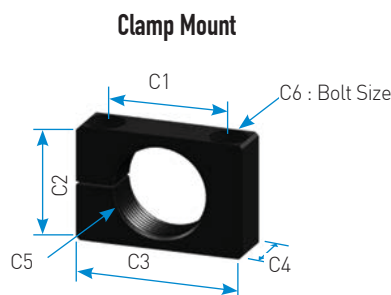
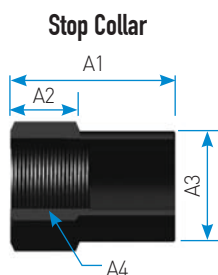

IASS12 - 10(B) / 14 - 15(B) / 14 - 15F(B)

Best engineered
for energy absorption
technology

Engineering Data

Model	Stroke (mm)	Max. Energy / Cycle(Nm)	Max. Energy / Hour (Nm / h)	Effective Weight(Kg)			Recoil Force(N)		Weight(g)
				S	M	H	Ext.	Comp.	
IASS12 - 10(B)	10	16	30,000	13~8	6.6~22	16~200	3.8	9.8	39
IASS14 - 15(B)	15	30	51,000	3.8~15	12~42	31~1500	3.8	13	61
- 15F(B)	15	30	51,000	3.8~15	12~42	31~1500	3.8	13	64

Dimensions

(unit : mm)

Model	Stroke	A	B	C	D	E	F	G	M	Dr
IASS12 - 10(B)	10	79	6.5	52.5	10	69	SW:10.8	Ø10.5	M12 X 1.0	Ø4
IASS14 - 15(B)	15	100.5	6.5	69	10	90.5	SW:11.8	Ø10.5	M14 X 1.5	Ø4
- 15F(B)	15	100.5	6.5	69	10	90.5	SW:11.8	Ø10.5	M14 X 1.0	Ø4

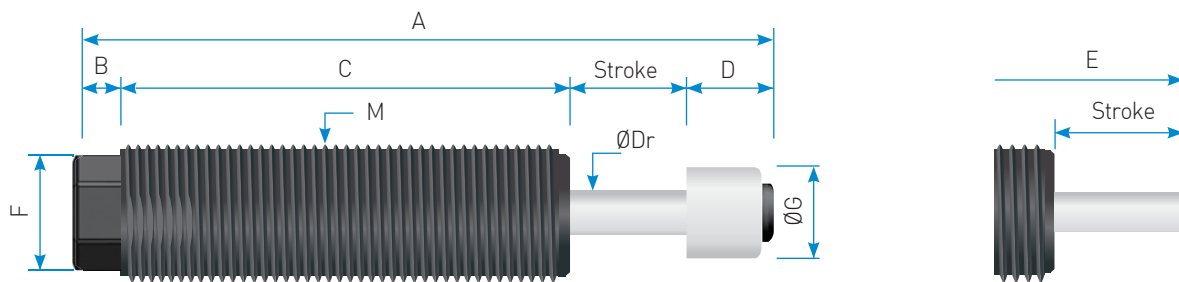

Steel head+Hard PU button
[B TYPE : Black]

Accessories

(unit : mm)

Model	Stop Collar				Clamp Mount						Lock Nut		
	A1	A2	A3	A4	C1	C2	C3	C4	C5	C6	D1	D2	D3
IASS12 - 10(B)	20	8	Ø13.8	M12 X 1.0	20	16	32	12	M12 X 1.0	M5 X 18L	14	M12 X 1.0	4
IASS14 - 15(B)	27	12	Ø18	M14 X 1.5	20	20	32	12	M14 X 1.5	M5 X 25L	19	M14 X 1.5	5
- 15F(B)	27	12	Ø18	M14 X 1.0	20	20	32	12	M14 X 1.0	M5 X 25L	19	M14 X 1.0	5

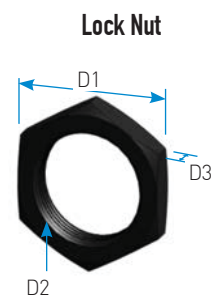
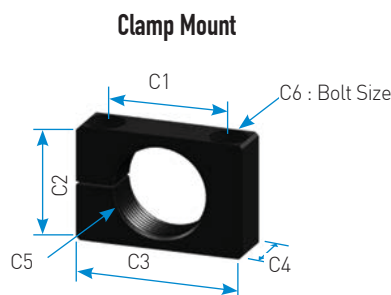
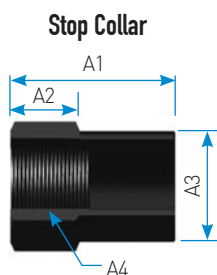

IASS20 - 20(B) / 25 - 25(B) / 25 - 25F(B)

Engineering Data

Model	Stroke (mm)	Max.Energy / Cycle(Nm)	Max.Energy / Hour (Nm / h)	Effective Weight(Kg)			Recoil Force(N)		Weight(g)
				S	M	H	Ext.	Comp.	
IASS20 - 20(B)	20	96	55,000	9~59	48~192	133~4,800	8.1	23	138
IASS25 - 25(B)	25	205	69,000	33~209	103~1,139	641~10,250	11	29	262
- 25F(B)	25	205	69,000	33~209	103~1,139	641~10,250	11	29	271

Dimensions

(unit : mm)

Model	Stroke	A	B	C	D	E	F	G	M	Dr
IASS20 - 20(B)	20	118.5	8	77	13.5	105	SW : 15	Ø13.5	M20 X 1.5	Ø6
IASS25 - 25(B)	25	141.5	9	91	16.5	125	SW : 19	Ø16	M25 X 2.0	Ø8
- 25F(B)	25	141.5	9	91	16.5	125	SW : 19	Ø16	M25 X 1.5	Ø8

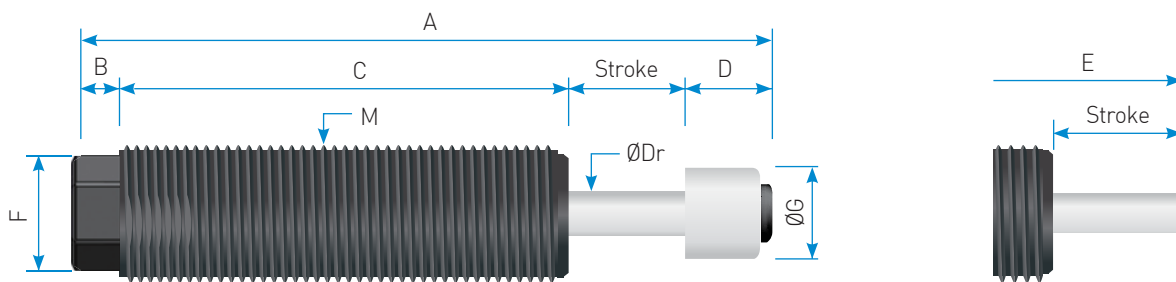

Steel head+Hard PU button
[B TYPE : Black]

Accessories

(unit : mm)

Model	Stop Collar				Clamp Mount						Lock Nut		
	A1	A2	A3	A4	C1	C2	C3	C4	C5	C6	D1	D2	D3
IASS20 - 20(B)	36	15	Ø24	M20 X 1.5	28	25	40	20	M20 X 1.5	M6 X 30L	24	M20 X 1.5	6
IASS25 - 25(B)	42	18	Ø31.5	M25 X 2.0	32	32	46	25	M25 X 2.0	M6 X 35L	32	M25 X 2.0	8
- 25F(B)	42	18	Ø31.5	M25 X 1.5	32	32	46	25	M25 X 1.5	M6 X 35L	32	M25 X 1.5	8

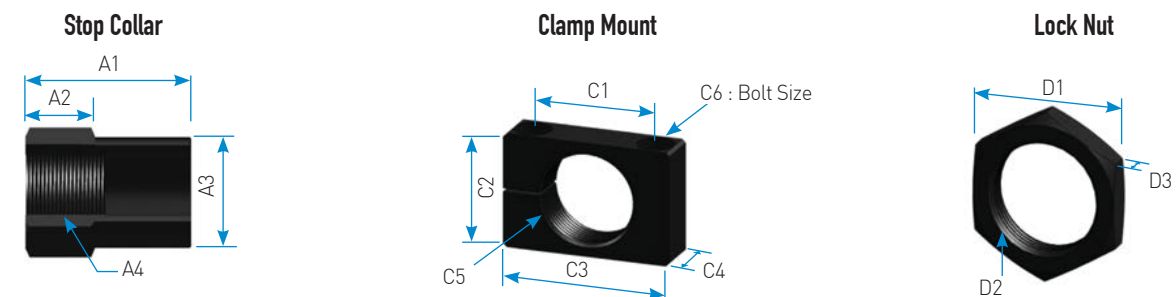

IASS36 - 25(B) / 36 - 50(B)

Best engineered
for energy absorption
technology

Engineering Data

Model	Stroke (mm)	Max. Energy / Cycle (Nm)	Max. Energy / Hour (Nm / h)	Effective Weight (Kg)			Recoil Force (N)		Weight (g)
				S	M	H	Ext.	Comp.	
IASS36 - 25(B)	25	490	115,000	61-185	170-500	435-10,888	25	64.3	758
- 50(B)	50	220	162,000	35-121	110-543	440-4,888	24.4	44.6	994

Dimensions

(unit : mm)

Model	Stroke	A	B	C	D	E	F	G	M	Dr
IASS36 - 25(B)	25	164	14	101	24	140	SW : 30	Ø28	M36 X 1.5	Ø10
- 50(B)	50	221	11	136	24	197	SW : 30	Ø28	M36 X 1.5	Ø10

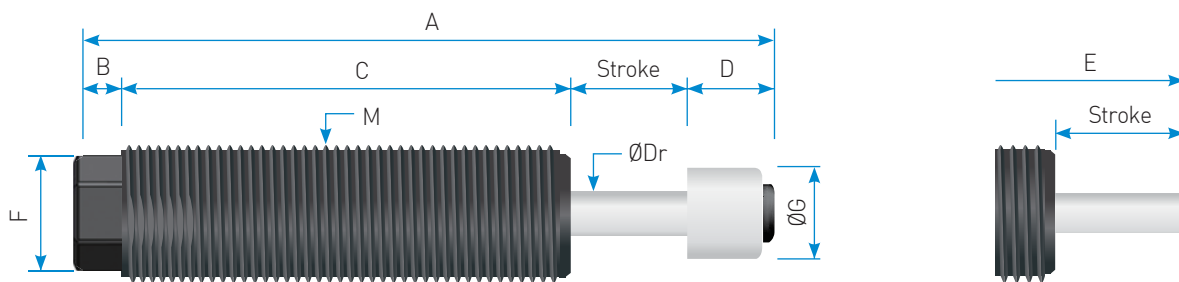

Steel head+Hard PU button
[B TYPE : Black]

Accessories

(unit : mm)

Model	Stop Collar				Clamp Mount						Lock Nut		
	A1	A2	A3	A4	C1	C2	C3	C4	C5	C6	D1	D2	D3
IASS 36 - 25(B)													
- 50(B)	62	26	Ø45	M36X1.5	45	42	61	25	M36X1.5	M6	46	M36X1.5	10

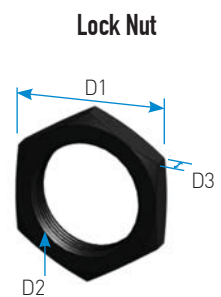
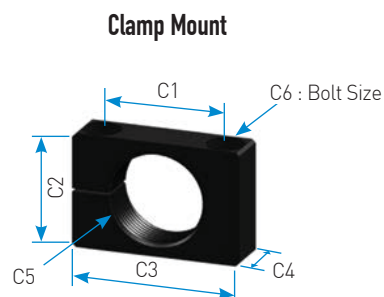
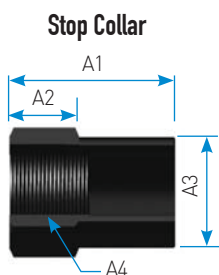

IAAH Series Mid dial type

IZMAC Absorber Adjustable Heavy type

DESCRIPTION

IAAH is mid large bore series heavy type shock absorber. Operation : when the collision comes piston compress oil chamber in inner tube according to the piston rod moving. Oil flows to accumulator through outside grooves in this process, deceleration power comes by flow resistance. And kinetic energy is dissipated in the air by changed as heat energy. Recoil Spring returns piston rod into its original position when the load is disappeared.

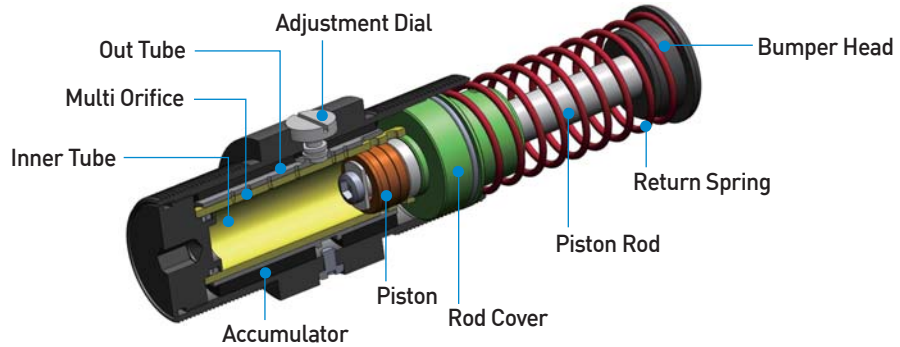

FEATURES

- 1 IAAH is dial type and it can set the speed ranges as 8 steps.
- 2 Improved energy capacity over 200% and effective weight ranges become wider than before.
- 3 All threaded body outside helps to install shock absorber and it can be fixed exact position. And it helps also to dissipate more shock energy by increased surface dimension.
- 4 Body surface treated as alloyed black colored steel or Zn-Ni and it develop anti corrosion features highly.
- 5 Stop collar is not necessary when shock absorber has steel head, and poly pad & urethane cap will helps to decrease collision noises efficiently.
- 6 Rod cover is made of long lasting materials with function of seal protection and that enable to guarantee long life.
- 7 Speed ranges standard : 0.3 ~ 3.5m/s • Low Velocity (LV) : Option
- 8 Temperature ranges standard : -10 ~ 80°C • Special : -40 ~ 120°C

IAAH SERIES ORDERING INFORMATION

IAAH - 42 - 50 - N - LV - SC

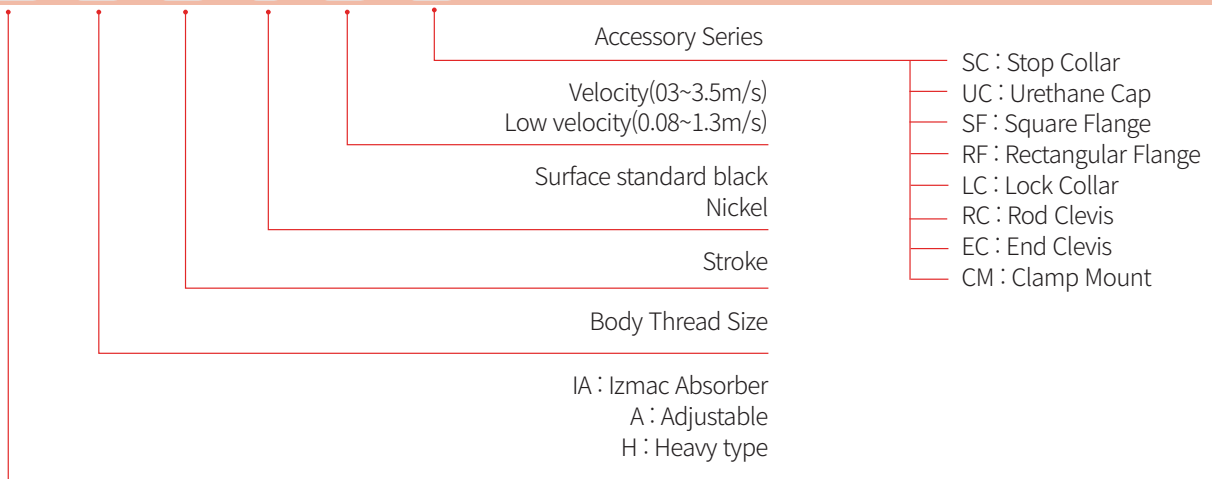

IAAH42 Series

Best engineered
for energy absorption
technology

Engineering Data

Model	Stroke (mm)	Max. Energy / Cycle(Nm)	Max. Energy / Hour (Nm / h)	Effective Weight(kg)	Recoil Forec(N)		Weight(g)
					Ext.	Comp.	
IAAH42 - 25	25	250	125,000	36 - 3,600	28	56	1.25
- 50	50	500	166,000	45 - 6,150	38	86	1.4
- 75	75	750	200,000	54 - 9,500	32	88	1.6

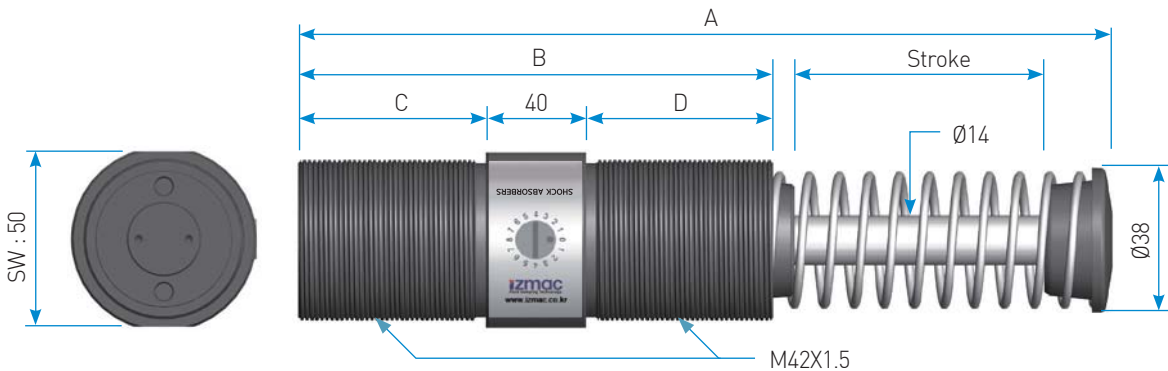

Clamp Mount

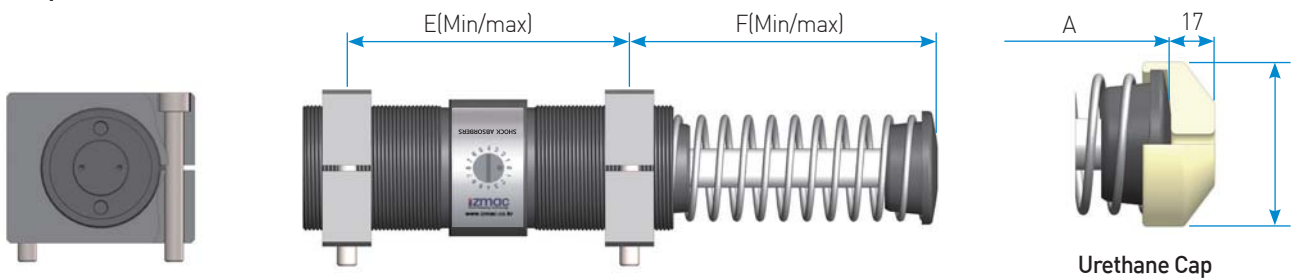

Clevis Mount

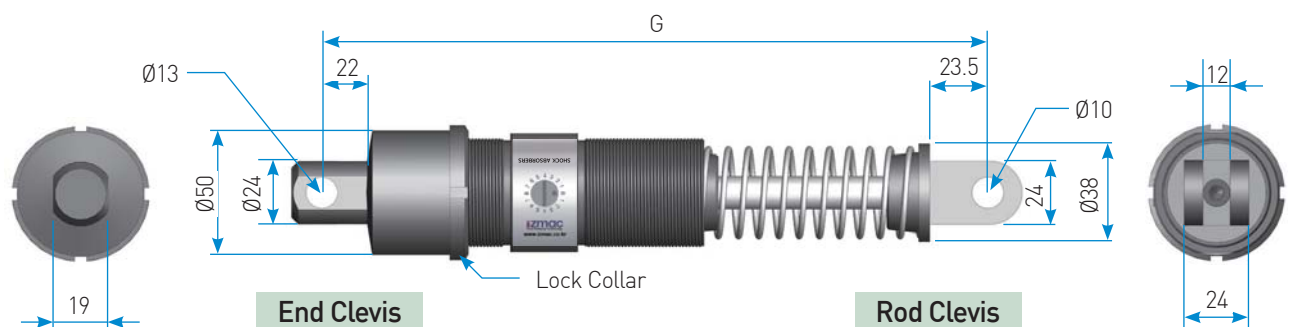

Dimensions

(unit : mm)

Model	Stroke	A	B	C	D	E(Min/Max)	F(Min/Max)	G
IAAH42 - 25	25	145	95	28	27	65/70	62.5/64.5	200
- 50	50	195	120	40	40	65/95	87.5/102.5	250
- 75	75	245	145	52	53	65/120	117.6/145.5	300

IAAH64 Series

Engineering Data

Model	Stroke (mm)	Max. Energy / Cycle(Nm)	Max. Energy / Hour (Nm / h)	Effective Weight(kg)	Recoil Forec(N)		Weight(g)
					Ext.	Comp.	
IAAH64 - 50	50	1,300	270,000	82 - 12,600	65	148	3.7
- 100	100	2,600	360,000	115 - 17,000	45	157	4.5
- 150	150	3,900	420,000	140 - 22,000	47	199	5.3

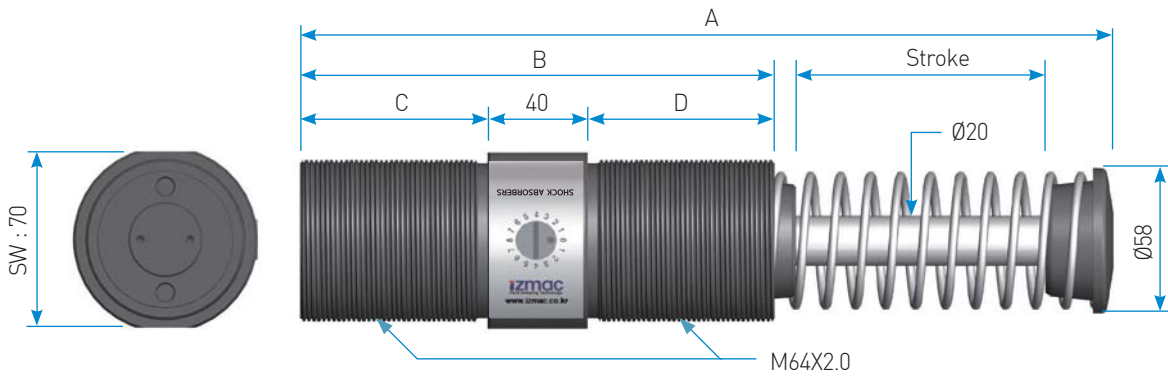

Clamp Mount

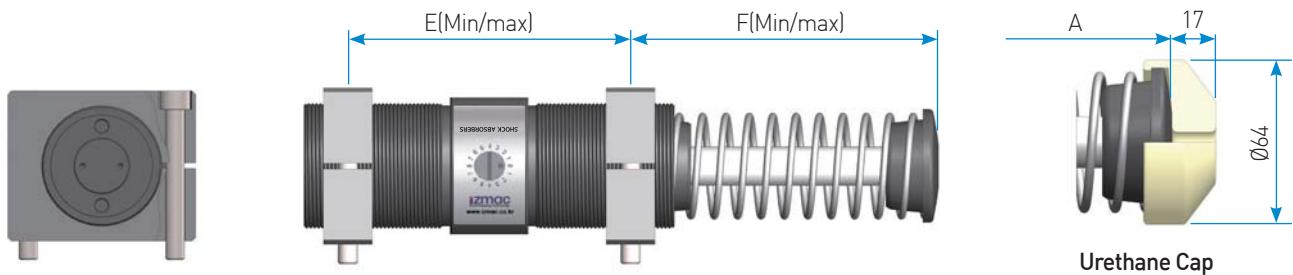

Clevis Mount

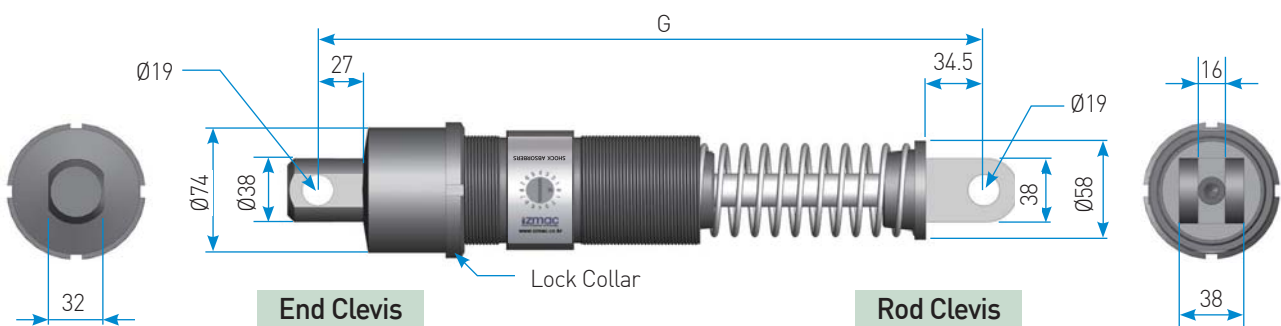

Dimensions

(unit : mm)

Model	Stroke	A	B	C	D	E(Min/Max)	F(Min/Max)	G
IAAH64 - 50	50	225	140	50	50	65/115	97.5/122.5	305
- 100	100	327	190	75	75	65/165	147.5/197.5	409
- 150	150	455	240	100	100	65/215	197.5/272.5	534

IAAH85 Series

Best engineered
for energy absorption
technology

Engineering Data

Model	Stroke (mm)	Max. Energy / Cycle(Nm)	Max. Energy / Hour (Nm / h)	Effective Weight(kg)	Recoil Forec(N)		Weight(g)
					Ext.	Comp.	
IAAH85 - 50	50	2,300	370,000	200 - 37,000	148	315	6.4
- 90	90	4,000	650,000	230 - 40,000	121	365	7.6
- 125	125	5,700	930,000	300 - 43,000	114	365	8.6
- 165	165	7,300	1,210,000	360 - 45,000	98	429	9.8

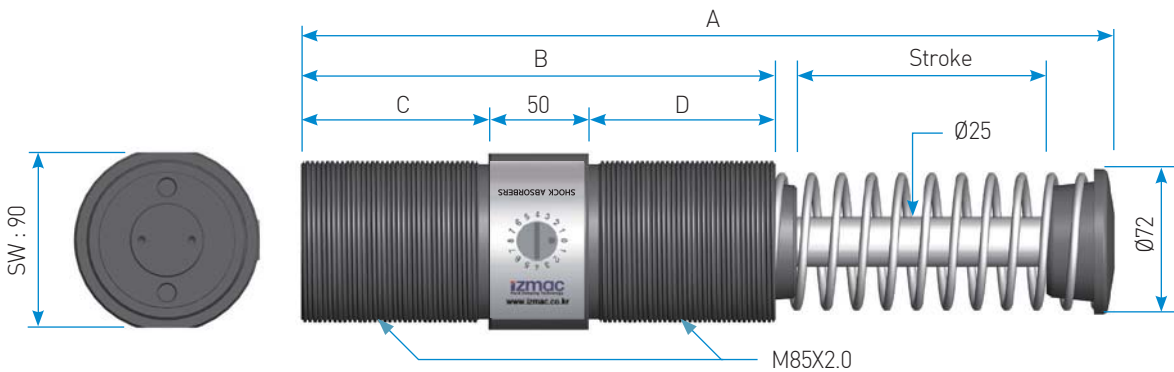

Clamp Mount

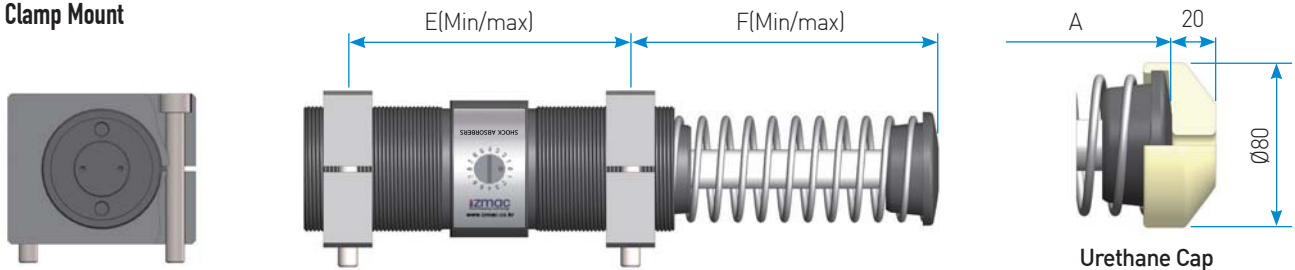

Clevis Mount

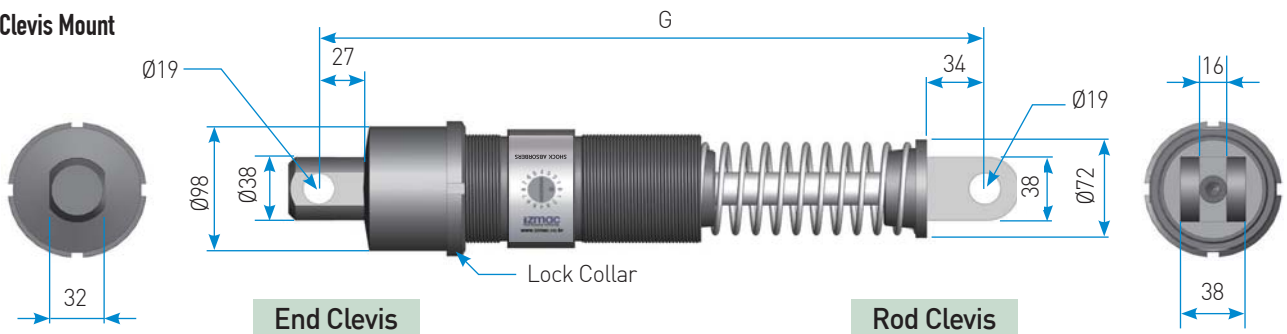

Dimensions

(unit : mm)

Model	Stroke	A	B	C	D	E(Min/Max)	F(Min/Max)	G
IAAH85 - 50	50	245	140	42	48	80/110	120/138	325
- 90	90	325	180	60	70	80/150	160/200	405
- 125	125	400	216	82	84	80/186	195/249	480
- 165	165	494	256	106	100	80/226	220/290	575

IAAH115 Series

Engineering Data

Model	Stroke (mm)	Max.Energy / Cycle(Nm)	Max.Energy / Hour (Nm / h)	Effective Weight(kg)	Recoil Forec(N)		Weight(g)
					Ext.	Comp.	
IAAH115 - 50	50	3,700	1,501,000	370 - 44,000	187	427	16
- 100	100	7,400	1,805,000	370 - 57,000	178	482	19
- 150	150	11,100	2,100,000	370 - 89,000	185	538	21
- 200	200	14,800	2,405,000	390 - 118,000	185	665	31
- 250	250	18,500	2,710,000	440 - 145,000	184	649	34

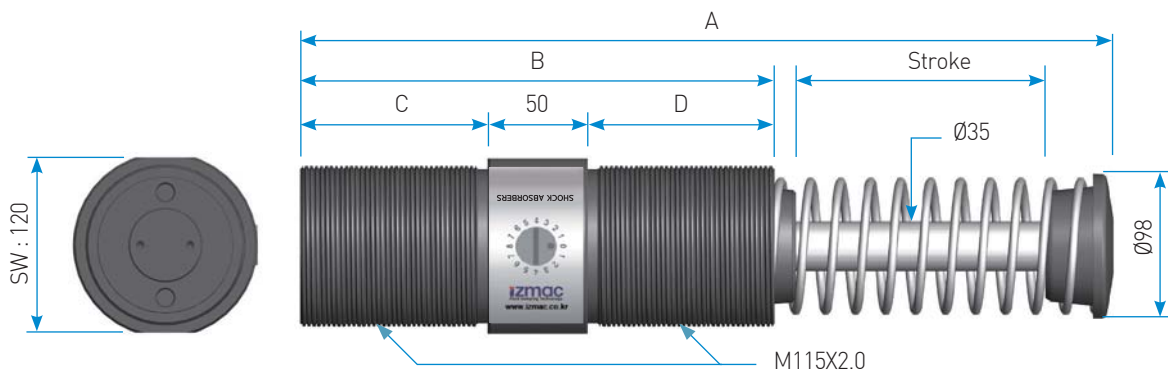

Clamp Mount

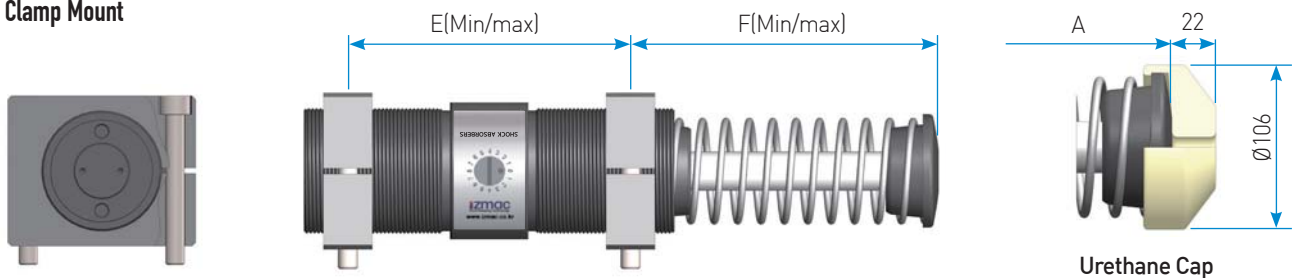

Clevis Mount

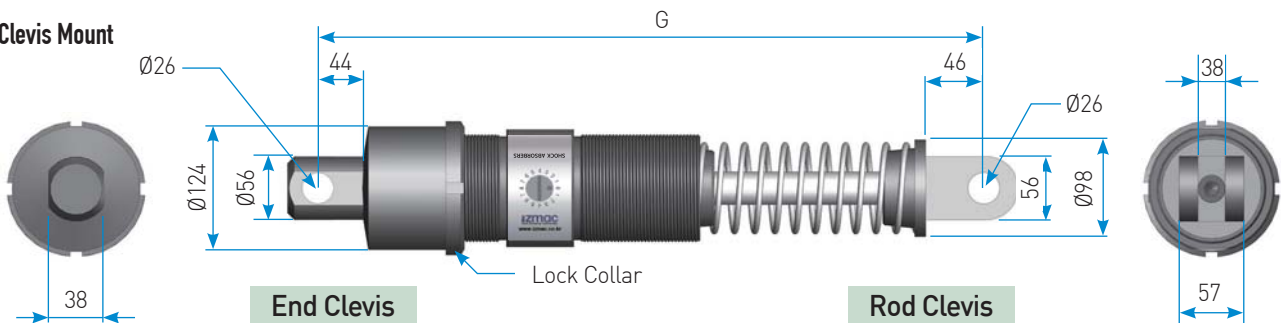

Dimensions

(unit : mm)

Model	Stroke	A	B	C	D	E(Min/Max)	F(Min/Max)	G
IAAH115 - 50	50	314	200	75	75	80/170	129/174	430
- 100	100	414	250	100	100	80/220	179/249	535
- 150	150	514	300	125	125	80/270	229/324	635
- 200	200	644	350	150	150	80/320	279/399	760
- 250	250	744	400	180	170	80/370	329/479	865



Accessories

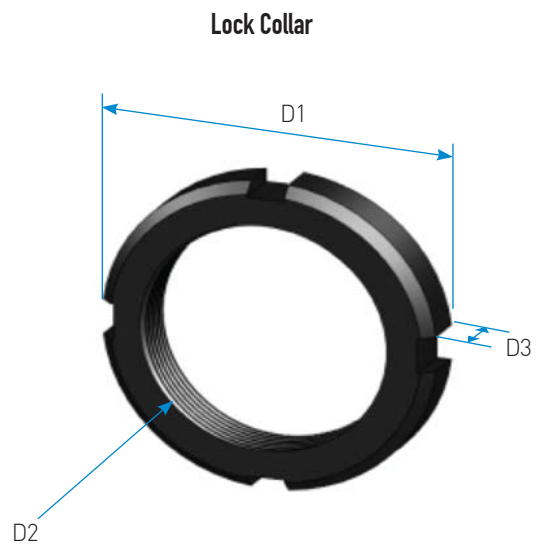
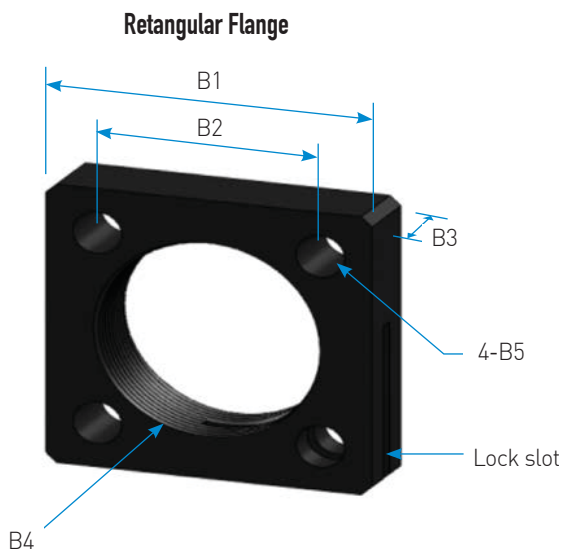
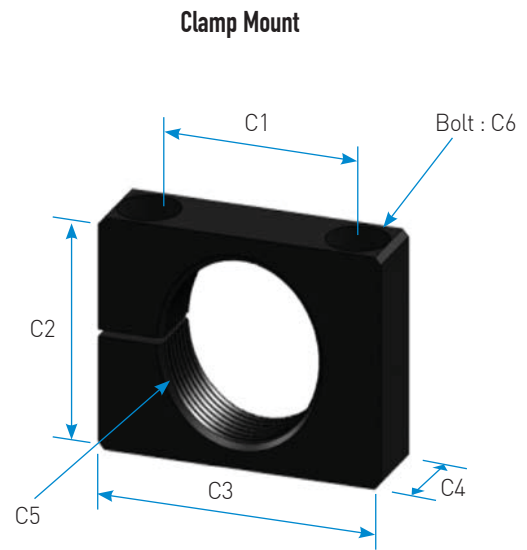
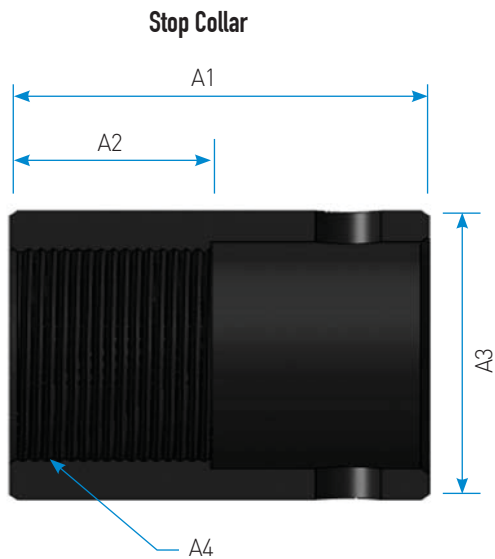

Dimensions

(unit : mm)

Model	StopCollar				Side Load Adapter					Clamp Mount						Lock Nut		
	A1	A2	A3	A4	B1	B2	B3	B4	B5	C1	C2	C3	C4	C5	C6	D1	D2	D3
IAAH45 - Series	52	25	Ø56	M42 X 1.5P	□60	□41	14	M42 X 1.5P	4 - Ø9	60	56	80	25	M42 X 1.5P	M8 X 60L	Ø58	M42 X 1.5P	9
IAAH64 - Series	85	45	Ø75	M64 X 2.0P	□90	□70	16	M64 X 2.0P	4 - Ø11	78	80	100	25	M64 X 2.0P	M10 X 80L	Ø80	M64 X 2.0P	11
IAAH85 - Series	95	45	Ø98	M85 X 2.0P	□104	□76	19	M85 X 2.0P	4 - Ø13	115	100	145	30	M85 X 2.0P	M14 X 100L	Ø110	M85 X 2.0P	16
IAAH115 - Series	130	70	Ø138	M115 X 2.0	□140	□111	25	M115 X 2.0	4 - Ø18	150	135	185	35	M115 X 2.0	M16 X 150L	Ø150	M115 X 2.0	19

IAAD Series Mid dial type

Izmac Absorber Adjustable straight type Double dial

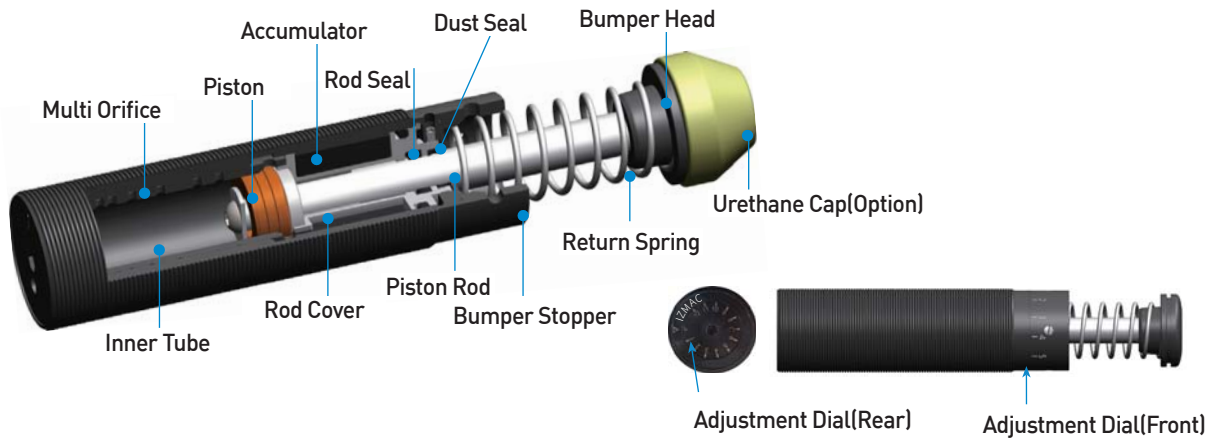

FEATURES

- 1 Depending on the collision speed, you can fit the buffer dial from 0 to 300 degrees in 12 steps.
- 2 Adjustment is easy in various installation environment by adopting front and rear adjustment dial.
- 3 Shock absorber body is built as one body, not only robust also fundamentally solves the shoot out trouble so called bottom out problem.
- 4 The entire body is threaded and easy to assemble. Also, due to the surface area is increased, the heat energy which comes from shock absorption can be emitted to the outside faster.
- 5 Piston rod is hard chrome-plated. Rod cover is a special material that can be used even for a long time, it protects seal and guarantees life.
- 6 Body surface treatment is resistant to corrosion by nickel plating or alloy plating (Black).
- 7 By using urethane cap, noise can be reduced.
- 8 Speed ranges standard : 0.3 ~ 5m/s • Low Velocity (LV) : Option
- 9 Temperature ranges standard : -10 ~ 80°C • Special : -40 ~ 120°C

APPLICATIONS

It is used throughout the industry such as robot, packing machine, loom, machine tool, automobile manufacturing facility, the manufacturing facility, casting facility, crane etc.

IAAD SERIES ORDERING INFORMATION

IAAD - 42 - 50 - N - SC

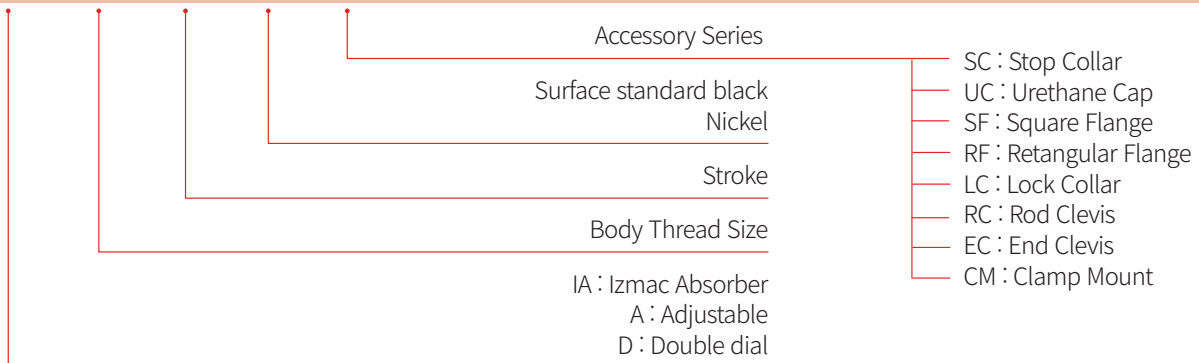

IAAD45 Series

Best engineered
for energy absorption
technology

Engineering Data

Model	Stroke (mm)	Max.Energy / Cycle(Nm)	Max.Energy / Hour (Nm / h)	Effective Weight(kg)	Recoil Forec(N)		Weight(kg)
					Ext.	Comp.	
IAAD45 - 25	25	650	195,000	50-13,354	49.7	82.8	1.13
- 50	50	1,300	260,000	99-26,700	45.6	54	1.3
- 75	75	2,000	300,000	148-39,060	44.3	86.3	1.52

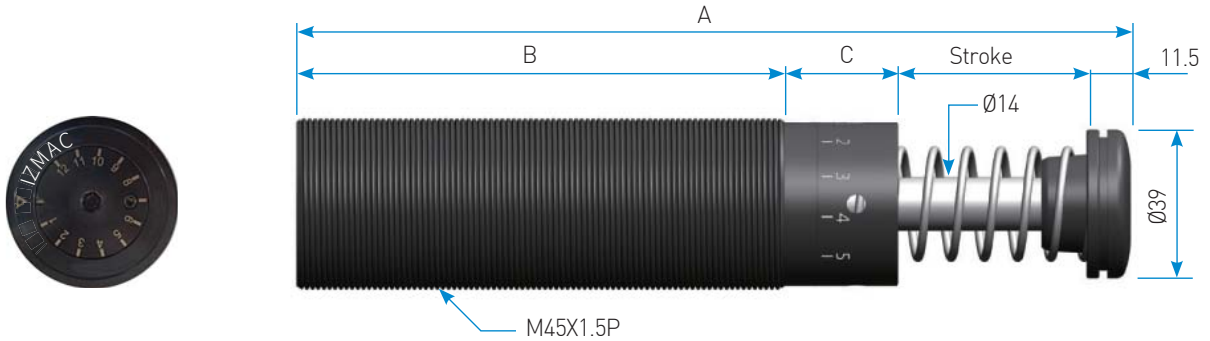

Dimensions

(unit : mm)

Model	Stroke	A	B	C
IAAD45 - 25	25	159.5	93	30
- 50	50	220.5	129	30
- 75	75	292.5	168.5	37.5

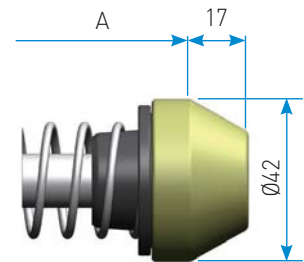

Clevis Mount

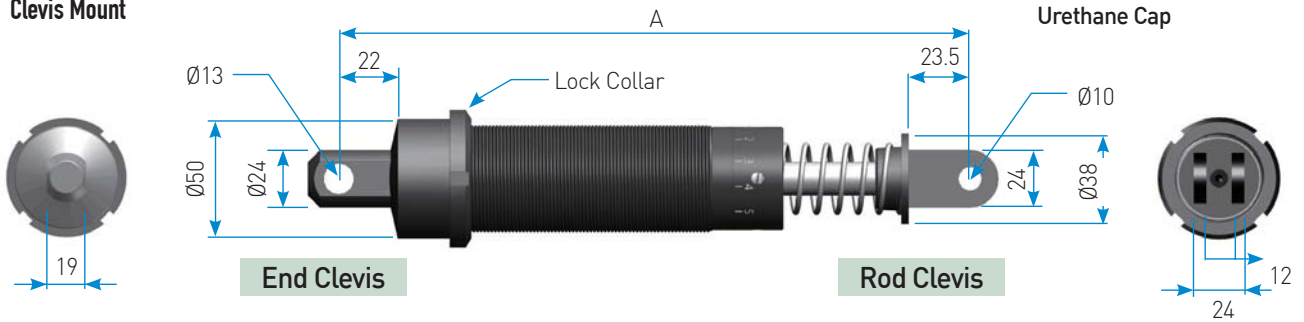

Clamp Mount

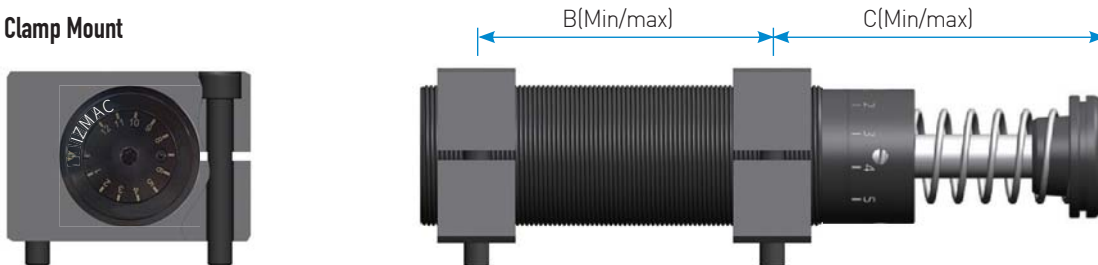

Accessories

(unit : mm)

Model	IAAD45-25	IAAD45-50	IAAD45-75
A	210	271	343
B(Min/Max)	25/68	25/104	25/143.5
C(Min/Max)	79.5/100.5	104/143.5	37.5/129/170.75

IAAD64 Series

Engineering Data

Model	Stroke (mm)	Max.Energy / Cycle(Nm)	Max.Energy / Hour (Nm / h)	Effective Weight(kg)	Recoil Forec(N)		Weight(kg)
					Ext.	Comp.	
IAAD64 - 25	25	1,250	152,000	92~24,400	61.8	110	2.9
- 50	50	2,500	248,000	185-48.800	60.8	133.2	3.3
- 75	75	3,750	265,000	277-73,240	61.4	148.3	3.8
- 100	100	5,000	360,000	370-97,650	59.4	140.1	4
- 125	125	6,250	413,000	462-122,000	57.1	160.4	7.7
- 150	150	7,500	450,000	555-146,480	51	166.8	8.9

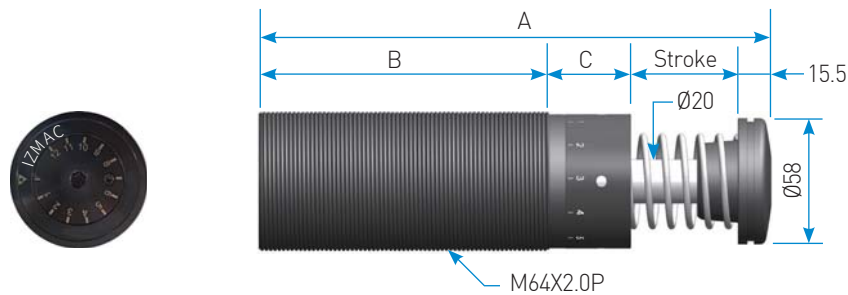

Dimensions

(unit : mm)

Model	Stroke	A	B	C
IAAD64 - 25	25	176	97.5	38
- 50	50	239	135.5	38
- 75	75	309	173.5	45
- 100	100	375	214.5	45
- 125	125	452	256.5	55
- 150	150	518.5	294.5	58.5

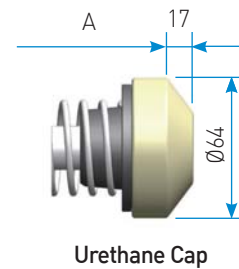

Clevis Mount

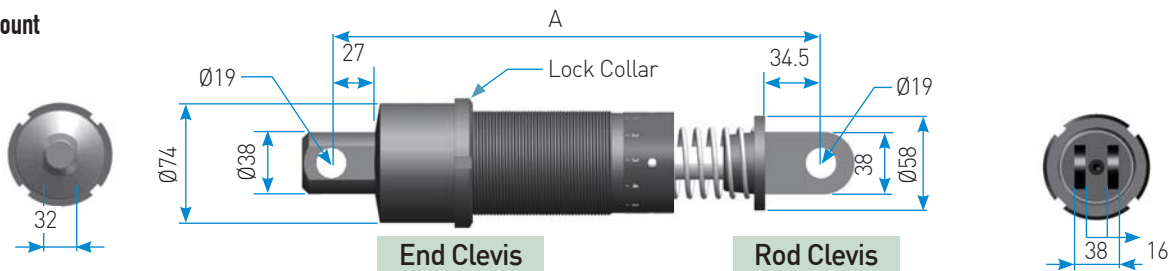

Clamp Mount

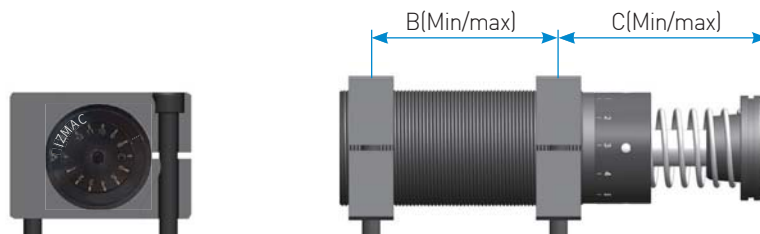

Accessories

(unit : mm)

Model	IAAD64 -25	IAAD64 -50	IAAD64 -75	IAAD64 -100	IAAD64 -125	IAAD64 -150
A	244	307	377	442	520	-
B(Min/Max)	25/72.5	25/110.5	25/148.5	25/189.5	25/231.5	25/269.5
C(Min/Max)	92.5/116.25	117.5/160.25	149.5/211.25	174.5/256.75	209.5/312.75	238/360.25

IAAD85 Series

Best engineered
for energy absorption
technology

Engineering Data

Model	Stroke (mm)	Max. Energy / Cycle(Nm)	Max. Energy / Hour (Nm / h)	Effective Weight(kg)	Recoil Forec(N)		Weight(kg)
					Ext.	Comp.	
IAAD85 - 25	25	2,000	330,000	148-39,600	132	245.8	12.2
- 50	50	4,000	462,000	296-78,100	131.6	271.7	14.4
- 75	75	6,000	680,000	444-117,200	130	325.1	17
- 100	100	8,000	825,000	591-156,300	125.4	327.7	20
- 125	125	10,000	859,000	740-195,300	126.6	343.3	23.6
- 150	150	12,000	901,000	930-220,300	126.6	386.7	28

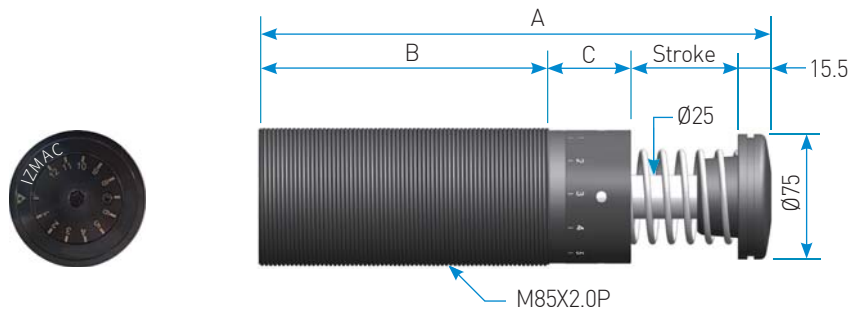

Dimensions

(unit : mm)

Model	Stroke	A	B	C
IAAD85 - 25	25	189.5	109	40
- 50	50	251	145.5	40
- 75	75	314.5	180	44
- 100	100	384.5	217	52
- 125	125	452.5	256	56
- 150	150	513.5	292	56

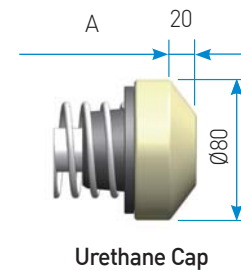

Urethane Cap

Clevis Mount

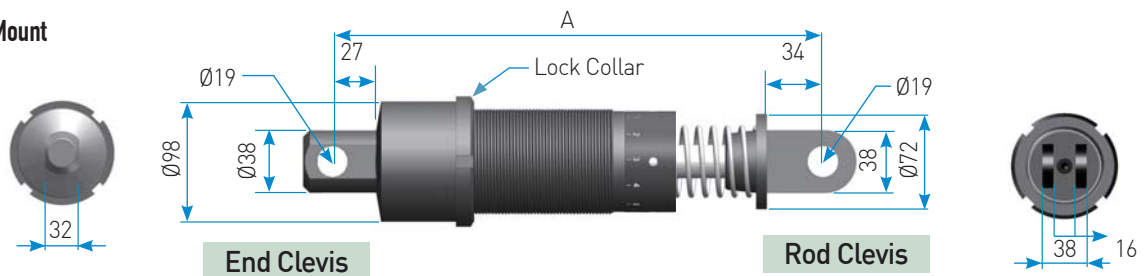

Clamp Mount

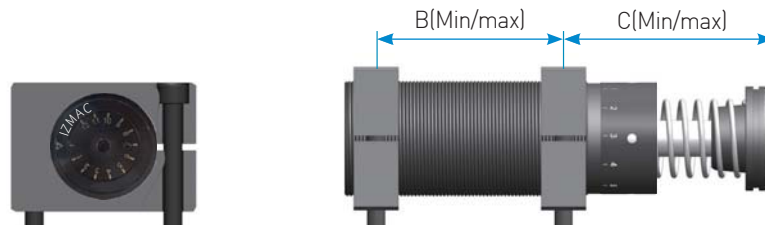

Accessories

(unit : mm)

Model	IAAD85 -25	IAAD85 -50	IAAD85 -75	IAAD85 -100	IAAD85 -125	IAAD85 -150
A	256	316	381	451	519	-
B(Min/Max)	25/79	25/114	25/150	25/187	25/226	25/262
C(Min/Max)	95.5/120	120.5/162.5	149/209.5	182.5/261	211.5/309.5	236.5/352.5

■ Accessories

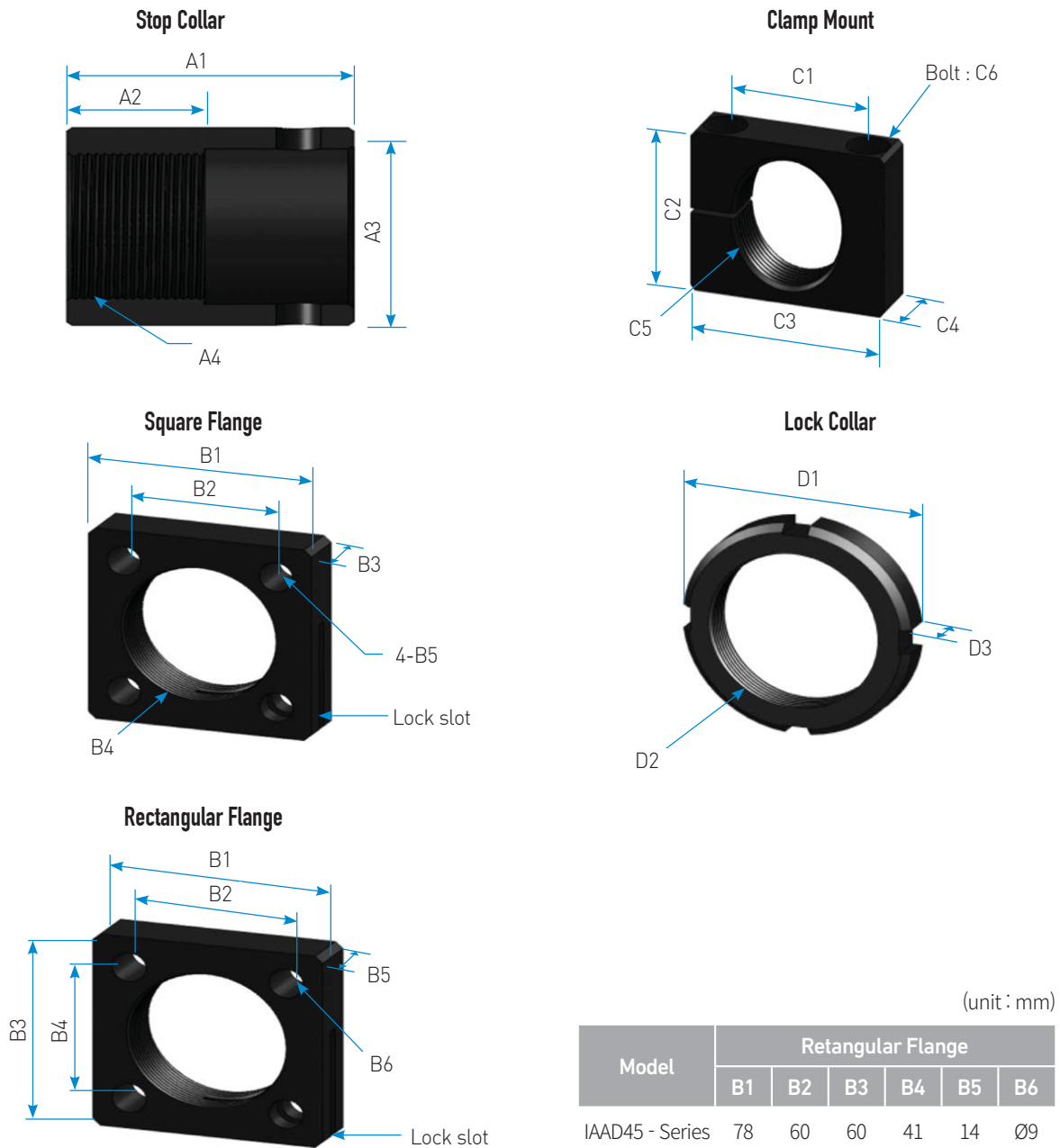

Model	Retangular Flange					
	B1	B2	B3	B4	B5	B6
IAAD45 - Series	78	60	60	41	14	Ø9
IAAD64 - Series	115	87.6	90	70	16	Ø11

■ Dimensions



(unit : mm)

Model	StopCollar				Side Load Adapter					Clamp Mount						Lock Collar		
	A1	A2	A3	A4	B1	B2	B3	B4	B5	C1	C2	C3	C4	C5	C6	D1	D2	D3
IAAD45 - Series	52	25	Ø56	M45 X 1.5P	□60	□41	14	M45 X 1.5P	Ø9	60	56	80	25	M45 X 1.5P	M8 X 60L	Ø58	M45 X 1.5P	9
IAAD64 - Series	85	45	Ø75	M64 X 2.0P	□90	□70	16	M64 X 2.0P	Ø11	78	80	100	25	M64 X 2.0P	M10 X 80L	Ø80	M64 X 2.0P	11
IAAD85 - Series	95	45	Ø98	M85 X 2.0P	□104	□76	19	M85 X 2.0P	Ø13	115	100	145	30	M85 X 2.0P	M14 X 100L	Ø110	M85 X 2.0P	16

IAAD Accessories : Instruction

Best engineered
for energy absorption
technology

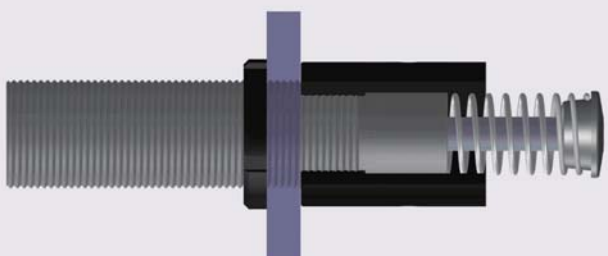
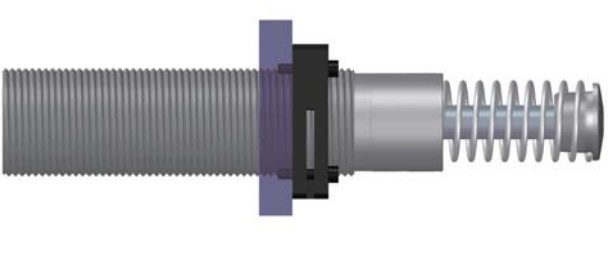
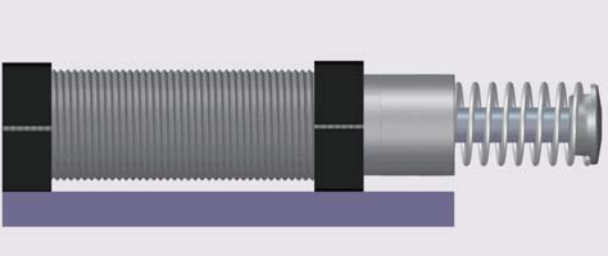

NAME	Installation Drawing	
Lock Collar		<p>As a basic mounting way by using lock collar, shock absorber can be installed easily.</p>
Stop Collar + Lock Collar		<p>Stop collar makes it easy to stop precisely and easy to select location to set and it prevents troubles so called bottom-out problem in the piston.</p>
Flange Mount		<p>Flange or rectangular flange can be used to fix the shock absorber conveniently.</p>
Clamp Mount		<p>Clamp mount is mainly used for horizontal surfaces and is useful when the length of the shock absorber is long.</p>
Clevis Mount		<p>It is mainly used in rotary motion and it is used to absorb shock indirectly by using clevis. Shock absorber can be protected from side loads.</p>

IASS Series Large bore Self compensating type

NEW

Izmac Absorber Self compensating Straight type

DESCRIPTION

IASS is middle class shock absorber. Operation : when the collision comes piston compress oil chamber in inner tube according to the piston rod moving. Oil flows to accumulator position through outskirts line of tube. In this process, deceleration power comes by flow resistance. And kinetic energy is dissipated in the air by changed as heat energy. Recoil spring returns piston rod into its original position when the load is disappeared.

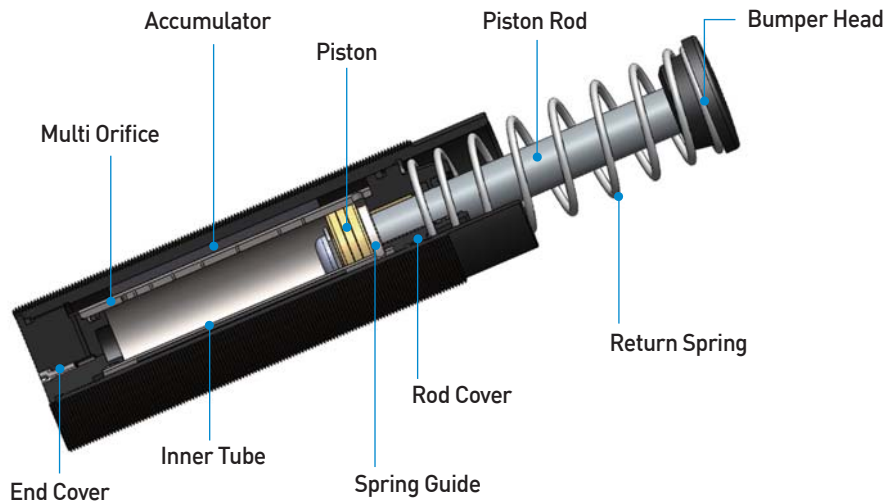

FEATURES

- 1 Compact design and possible to absorb wide range of high shock energy.
- 2 The effective weight range is significantly expanded, resulting in a wide range of energy absorption capabilities.
- 3 Easy fastening and smooth heat dissipation due to the screw-type body.
- 4 Body surface strongly treated to prevent corrosion by nickel plating or alloy plating. (Black)
- 5 Body and mount : Black or Ni plating
- 6 Piston rod : Hard chrome (25 μ or more)
- 7 Speed range : 0.15~5 m/s
- 8 Temperature range standard : -10 ~ 80°C • Special : -40 ~ 120°C

IASS SERIES ORDERING INFORMATION

IASS - 45 - 25 - LC

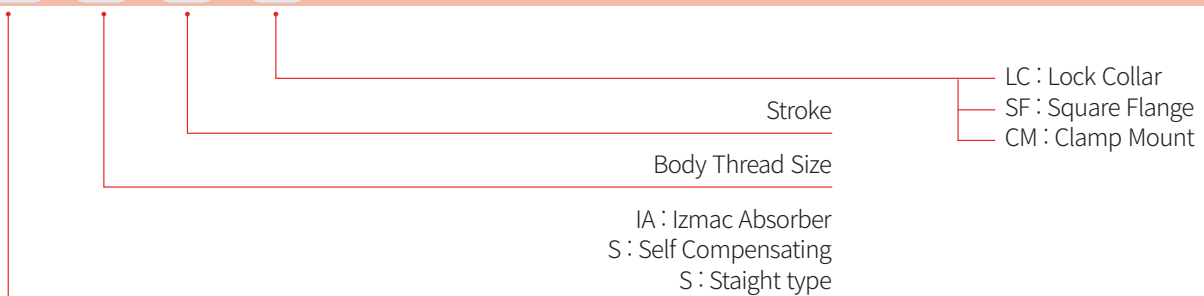

Engineering Data

Model	Stroke (mm)	Max.Energy / Cycle(Nm)	Max.Energy / Hour (Nm / h)	Effective Weight(kg)		Recoil Forec(N)		Weight(g)
						Ext.	Comp.	
IASS45 - 25 - 1	25	850	255,000	20	100	75	110	1.2
- 25 - 2	25	850	255,000	88	425	75	110	1.2
- 25 - 3	25	850	255,000	250	1,800	75	110	1.2
- 25 - 4	25	850	255,000	1,500	7,200	75	110	1.2
- 25 - 5	25	850	255,000	6,000	38,500	75	110	1.2
IASS45 - 50 - 1	50	1,300	325,000	32	155	75	150	1.4
- 50 - 2	50	1,300	325,000	134	650	75	150	1.4
- 50 - 3	50	1,300	325,000	385	2,800	75	150	1.4
- 50 - 4	50	1,300	325,000	2,300	11,000	75	150	1.4
- 50 - 5	50	1,300	325,000	3,200	58,900	75	150	1.4
IASS45 - 75 - 1	75	2,100	420,000	52	250	60	185	1.6
- 75 - 2	75	2,100	420,000	217	1,000	60	185	1.6
- 75 - 3	75	2,100	420,000	621	4,550	60	185	1.6
- 75 - 4	75	2,100	420,000	3,810	17,800	60	185	1.6
- 75 - 5	75	2,100	420,000	14,900	95,200	60	185	1.6

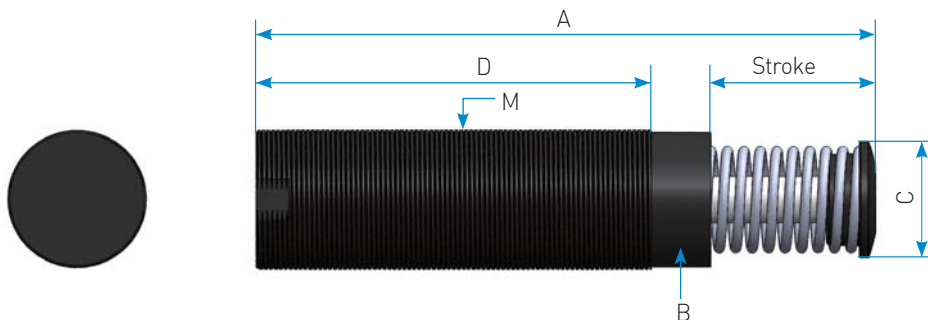

Dimensions

(unit : mm)

Model	Stroke	A	B	C	D	M
IASS45 - 25	25	145	Ø42	Ø35	95	M45 X 1.5P
- 50	50	195	Ø42	Ø35	120	M45 X 1.5P
- 75	75	246	Ø42	Ø35	145	M45 X 1.5P

Accessory

(unit : mm)

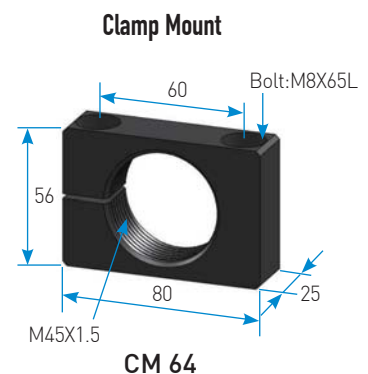
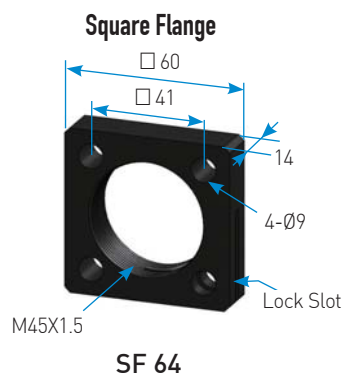
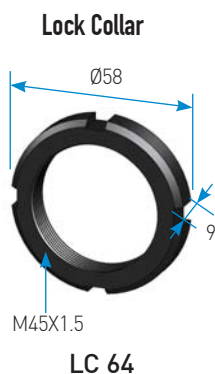

IASS64 Series

Engineering Data

Model	Stroke (mm)	Max.Energy / Cycle(Nm)	Max.Energy / Hour (Nm / h)	Effective Weight(kg)		Recoil Forec(N)		Weight(g)
						Ext.	Comp.	
IASS64 - 50 - 1	50	2,400	240,000	59	286	95	160	3
- 50 - 2	50	2,400	240,000	248	1,200	95	160	3
- 50 - 3	50	2,400	240,000	710	5,200	95	160	3
- 50 - 4	50	2,400	240,000	4,300	20,400	95	160	3
- 50 - 5	50	2,400	240,000	17,000	108,800	95	160	3
IASS64 - 100 - 1	100	5,000	350,000	123	595	110	275	3.7
- 100 - 2	100	5,000	350,000	517	2,500	110	275	3.7
- 100 - 3	100	5,000	350,000	1,480	10,800	110	275	3.7
- 100 - 4	100	5,000	350,000	9,000	42,500	110	275	3.7
- 100 - 5	100	5,000	350,000	35,600	226,700	110	275	3.7
IASS64 - 150 - 1	150	8,000	400,000	198	952	80	370	5
- 150 - 2	150	8,000	400,000	826	4,000	80	370	5
- 150 - 3	150	8,000	400,000	2,300	17,300	80	370	5
- 150 - 4	150	8,000	400,000	14,500	68,000	80	370	5
- 150 - 5	150	8,000	400,000	16,000	362,000	80	370	5

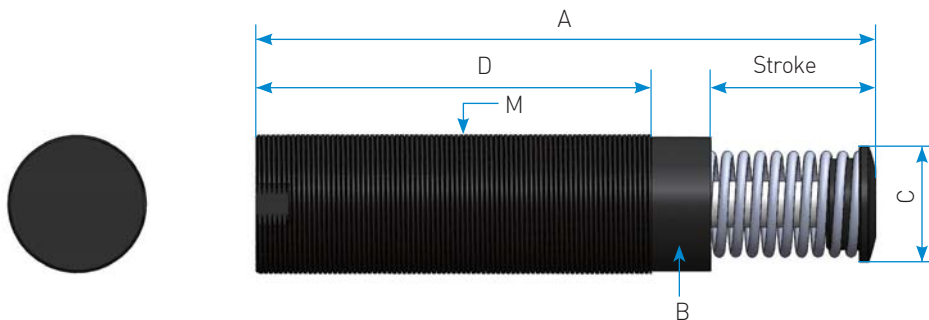

Dimensions

(unit : mm)

Model	Stroke	A	B	C	D	M
IASS64 - 50	50	225	60	48	140	M64 X 2.0P
- 100	100	326	60	48	191	M64 X 2.0P
- 150	150	450	60	48	241	M64 X 2.0P

Accessory

(unit : mm)

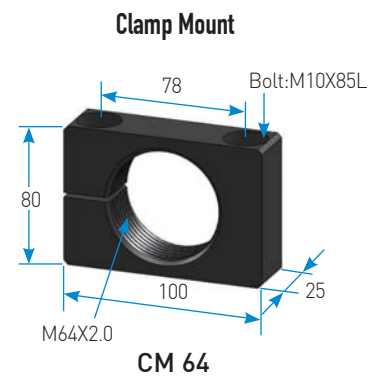
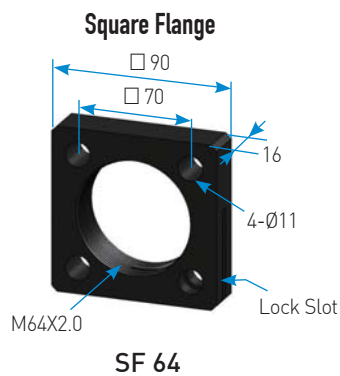
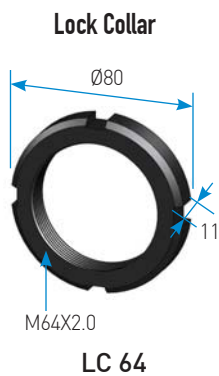



Engineering Data

Model	Stroke (mm)	Max. Energy / Cycle(Nm)	Max. Energy / Hour (Nm / h)	Effective Weight(kg)		Recoil Forec(N)		Weight(g)
						Ext.	Comp.	
IASS85 - 50 - 1	50	4,000	1,200,000	99	470	140	330	7
- 50 - 2	50	4,000	1,200,000	410	2,000	140	330	7
- 50 - 3	50	4,000	1,200,000	1,100	8,600	140	330	7
- 50 - 4	50	4,000	1,200,000	7,200	34,000	140	330	7
- 50 - 5	50	4,000	1,200,000	28,400	181,000	140	330	7
IASS85 -100 - 1	100	8,500	1,700,000	210	1,000	120	420	9
-100 - 2	100	8,500	1,700,000	878	4,250	120	420	9
-100 - 3	100	8,500	1,700,000	2,500	18,400	120	420	9
-100 - 4	100	8,500	1,700,000	15,400	72,200	120	420	9
-100 - 5	100	8,500	1,700,000	60,500	385,000	120	420	9
IASS85 - 150 - 1	150	13,500	2,025,000	330	1,600	110	430	12
- 150 - 2	150	13,500	2,025,000	1,400	6,700	110	430	12
- 150 - 3	150	13,500	2,025,000	3,900	29,000	110	430	12
- 150 - 4	150	13,500	2,025,000	24,500	114,000	110	430	12
- 150 - 5	150	13,500	2,025,000	96,100	612,000	110	430	12
IASS85 - 200 - 1	200	19,000	2,660,000	469	2,200	100	430	15
- 200 - 2	200	19,000	2,660,000	1,900	9,500	100	430	15
- 200 - 3	200	19,000	2,660,000	5,600	41,200	100	430	15
- 200 - 4	200	19,000	2,660,000	34,400	161,000	100	430	15
- 200 - 5	200	19,000	2,660,000	135,000	861,000	100	430	15
IASS85 - 250 - 1	250	23,500	2,820,000	580	2,800	95	430	20
- 250 - 2	250	23,500	2,820,000	2,400	11,700	95	430	20
- 250 - 3	250	23,500	2,820,000	6,900	50,900	95	430	20
- 250 - 4	250	23,500	2,820,000	42,600	199,000	95	430	20
- 250 - 5	250	23,500	2,820,000	167,000	1,065,000	95	430	20

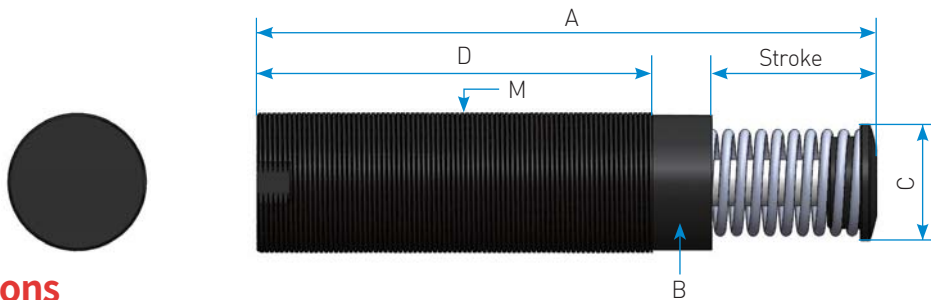

Dimensions

Model	Stroke	A	B	C	D	M
IASS85 - 50	50	258	81	68	165	M85 X 2.0P
- 100	100	360	81	68	218	M85 X 2.0P
- 150	150	485	81	68	285	M85 X 2.0P
- 200	200	590	81	68	330	M85 X 2.0P
- 250	250	700	81	68	390	M85 X 2.0P

Accessory

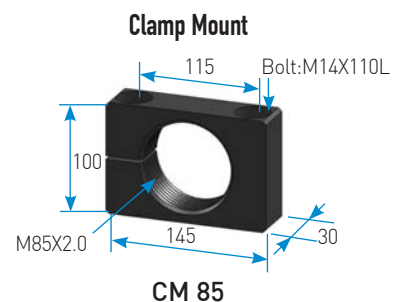
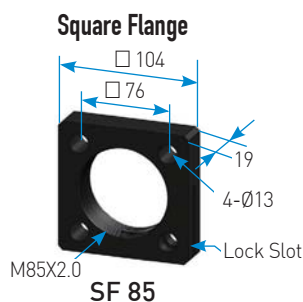

IASS115 Series

Best Engineered
For Energy Absorption!
Technology

Engineering Data

Model	Stroke (mm)	Max.Energy / Cycle(Nm)	Max.Energy / Hour (Nm / h)	Effective Weight(kg)		Recoil Forec(N)		Weight(g)
						Ext.	Comp.	
IASS115 - 50 - 1	50	11,000	3,300,000	272	1,300	220	480	12
- 50 - 2	50	11,000	3,300,000	1,100	5,500	220	480	12
- 50 - 3	50	11,000	3,300,000	3,200	23,800	220	480	12
- 50 - 4	50	11,000	3,300,000	19,900	93,500	220	480	12
- 50 - 5	50	11,000	3,300,000	78,300	498,000	220	480	12
IASS115 - 100 - 1	100	22,600	4,520,000	558	2,600	220	550	14
- 100 - 2	100	22,600	4,520,000	2,300	11,300	220	550	14
- 100 - 3	100	22,600	4,520,000	6,600	49,000	220	550	14
- 100 - 4	100	22,600	4,520,000	40,900	192,000	220	550	14
- 100 - 5	100	22,600	4,520,000	160,000	1,024,000	220	550	14
IASS115 - 150 - 1	150	34,000	5,100,000	840	4,000	200	570	17
- 150 - 2	150	34,000	5,100,000	3,500	17,000	200	570	17
- 150 - 3	150	34,000	5,100,000	10,000	73,700	200	570	17
- 150 - 4	150	34,000	5,100,000	61,600	289,000	200	570	17
- 150 - 5	150	34,000	5,100,000	242,000	1,541,000	200	570	17
IASS115 - 200 - 1	200	45,000	6,300,000	1,100	5,300	180	570	20
- 200 - 2	200	45,000	6,300,000	4,600	22,500	180	570	20
- 200 - 3	200	45,000	6,300,000	13,300	97,600	180	570	20
- 200 - 4	200	45,000	6,300,000	81,600	382,000	180	570	20
- 200 - 5	200	45,000	6,300,000	320,000	2,040,000	180	570	20
IASS115 - 250 - 1	250	56,000	6,720,000	1,300	6,600	200	620	25
- 250 - 2	250	56,000	6,720,000	5,700	28,000	200	620	25
- 250 - 3	250	56,000	6,720,000	16,500	121,000	200	620	25
- 250 - 4	250	56,000	6,720,000	101,000	476,000	200	620	25
- 250 - 5	250	56,000	6,720,000	398,000	2,539,000	200	620	25

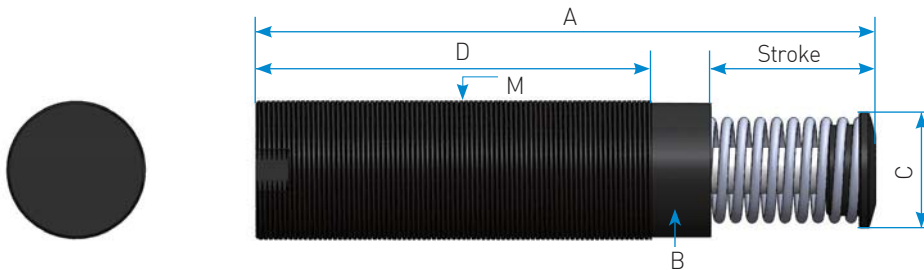

Dimensions

(unit : mm)

Model	Stroke	A	B	C	D	M
IASS115 - 50	50	310	Ø111	Ø98	205	M115 X 2.0P
- 100	100	420	Ø111	Ø98	265	M115 X 2.0P
- 150	150	535	Ø111	Ø98	315	M115 X 2.0P
- 200	200	655	Ø111	Ø98	380	M115 X 2.0P
- 250	250	770	Ø111	Ø98	435	M115 X 2.0P

Accessory

(unit : mm)

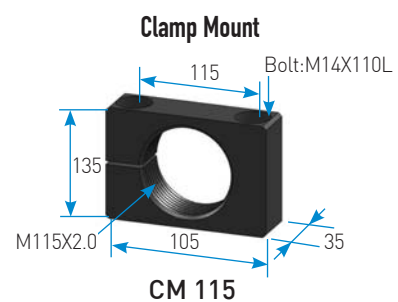
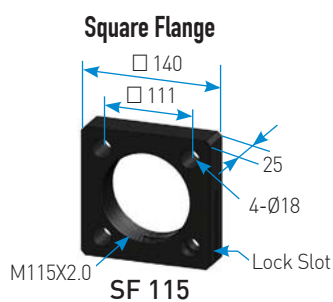



Symbols

Symbol	Unit	Description	Symbol	Unit	Description
m	kg	Weight	r	m	Radius of rotation
m_e	kg	Designed/weight	g	m/s^2	Gravitational acceleration
H	m	Height	d	m/s^2	Deceleration
S	m	Stroke	E_k	Nm	Kinetic energy
V	m/s	Impact velocity	E_w	Nm	Work energy
V_e	m/s	Designed velocity	E_T	Nm	Total energy
ω	rad/s	Angular velocity	F_D	N	Propelling force
I	Nms^2	Mass moment	F_s	N	Impact force
T	Nm	Torque	η	s	Efficiency rate

Useful Formulas

Maximum Shock Force	$FS = ET / S / 0.8 + FD$
Stroke	$S = V^2 / 2 / d / 0.8$
Deceleration	$d = V^2 / 2 / S / 0.8$
Deceleration Time	$t = 2.6 X S / V$

BUFFER SIZING

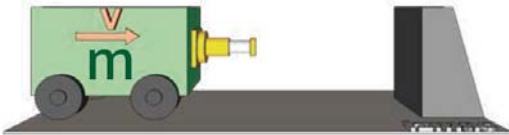
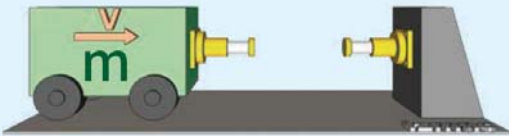
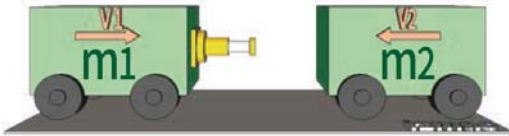
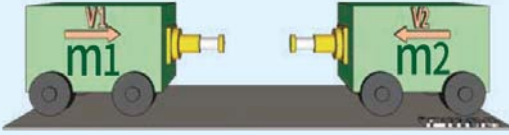
Arrangement	Design Speed (VE)	Design Weight (WE)
	V	m
	$\frac{V}{2}$	2m
	$V_1 + V_2$	$\frac{m_1 \times m_2}{m_1 + m_2}$
	$\frac{V_1 + V_2}{2}$	$\frac{2 \times m_1 \times m_2}{m_1 + m_2}$

■ Sizing Examples

| A | Horizontal Mass without Propelling Force

- Weight $m = 100\text{ton}$
- Impact velocity $V = 0.5\text{m/s}$

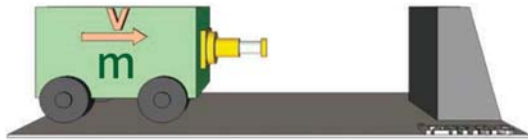

$$E_k = \frac{m \times V^2}{2} = \frac{100 \times 0.5^2}{2} = 12.5 \text{ kNm}$$

Selected Model with E_k : IBSG65-200

$$E_T = E_k + E_w = 12.5 + 0 = 12.5 \text{ kNm}$$

$$F_s = \frac{E_T}{(S \times \eta) + F_D} = \frac{12.5}{(0.2 \times 0.8) + 0} = 78.13 \text{ kN}$$

Selected Model with E_T & F_s : IBSG65-200

| B | Horizontal Mass with Propelling Force [Motor]

- Weight $m = 100\text{kg}$
- Cycles per hour $C = 600\text{Cycles/h}$
- Impact velocity $V = 1.5\text{m/s}$

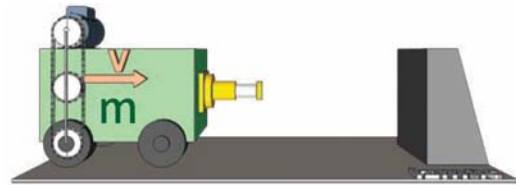

$$E_k = \frac{m \times V^2}{2} = \frac{160 \times 1.5^2}{2} = 180 \text{ kNm}$$

Selected Model with E_k : IBSG140-400

$$E_w = F_D \times S = 20 \times 0.4 = 8 \text{ kNm}$$

$$E_T = E_k + E_w = 12.5 + 0 = 12.5 \text{ kNm}$$

$$F_s = \frac{E_T}{(S \times \eta) + F_D} = \frac{180 + 8}{(0.4 \times 0.8) + 20} = 607.5 \text{ kN}$$

Selected Model with E_T & F_s : IBSG65-200

| C | Free Falling Mass

- Weight $m = 4\text{ton}$
- Height $H = 0.3\text{m}$

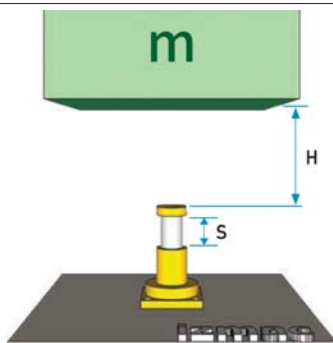

$$E_k = m \times g \times H = 4 \times 9.81 \times 0.3 = 11.772 \text{ kNm}$$

Selected Model with E_k : IBSG100-10

$$E_w = m \times g \times S = 4 \times 9.81 \times 0.1 = 3.924 \text{ kNm}$$

$$E_T = E_k + E_w = 11.772 + 3.924 = 15.696 \text{ kNm}$$

$$F_s = \frac{E_T}{(S \times \eta) + F_D} = \frac{15.696}{(0.1 \times 0.8) + 0} = 196.2 \text{ kN}$$

Selected Model with E_T & F_s : IBSG100-100

| D | Swiveling Mass with Propelling Force

- Torque $T = 200\text{Nm}$
- Impact velocity $\omega = 2\text{rad/s}$
- Radius of gyration $r = 8\text{m}$
- Mass moment of inertia $I = 35 \text{ Nms}^2$
- Stroke $S = 0.2 \text{ m}$

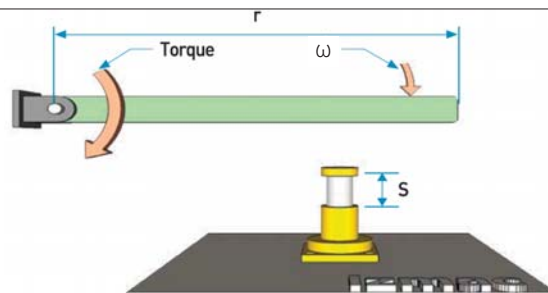

$$E_k = \frac{I \times \omega^2}{2} = \frac{35 \times 2^2}{2} = 70 \text{ kNm}$$

Selected Model with E_k : IBSG120-200

$$E_w = \frac{T \times S}{r} = \frac{200 \times 0.2}{8} = 5 \text{ kNm}$$

$$E_T = E_k + E_w = 70 + 5 = 75 \text{ kNm}$$

$$F_s = \frac{E_T}{(S \times \eta) + F_D} = \frac{75}{(0.2 \times 0.8) + 0} = 468.75 \text{ kN}$$

Selected Model with E_T & F_s : IBSG120-200

IBSG Series

DESCRIPTION

IBSG is a heavy-duty application product that has a high impact energy absorption capacity compared to its size. Operation : When an object collides, the piston enters the oil chamber by the tube shape piston rod, and the oil flows through the orifice of the throttle port and finally oil is pushing floating piston up to compress gas. In this process, flow resistance power arises, and gas pressure takes a role of accumulator which compensates piston rod space. Compressed gas has the role of returning piston rod to its original position when the load is released.

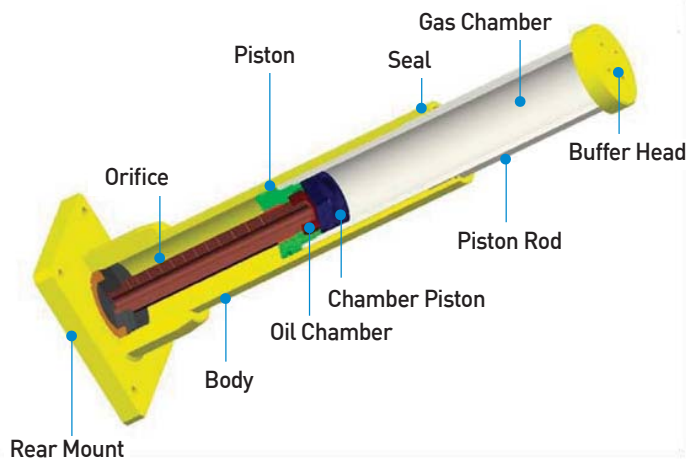

FEATURES

- 1 IBSG has over 90% high capable efficient energy hydraulic buffer.
- 2 Customizing orifice
- 3 Fulfilled international standards : OSHA, AIST, CMMA, DIN, FEM etc.
- 4 Operation temperature Standard : -10 ~ 80°C • Special : -40 ~ 120°C
- 5 Piston rod surface treatment : Hard Chrome Plated
- 6 Body surface treatment : Epoxy Painting

APPLICATION

Container crane, overhead crane, stacker crane, transfer car, rail end stop, heavy industry, steel mill

IBSG SERIES ORDERING INFORMATION

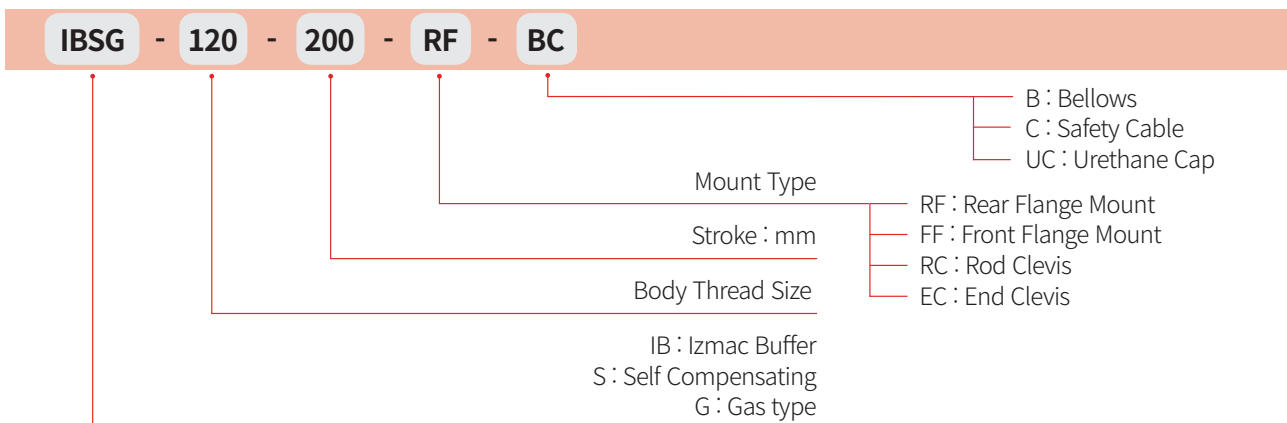

IBSG65 Series

Engineering Data

Model	Stroke (mm)	Max.Energy / Cycle(kJ)	Max.Buffer Force (kJ)	Recoil Force (kN)		Weight(kg)
				Ext.	Comp.	
IBSG65 - 50	50	3.8	95	1.0	3.5	6
- 75	75	5.7	95	1.0	3.5	8
- 100	100	7.5	95	1.0	3.5	9
- 150	150	11	95	1.0	3.5	11
- 200	200	14.7	95	1.0	3.5	12

Rear Mount

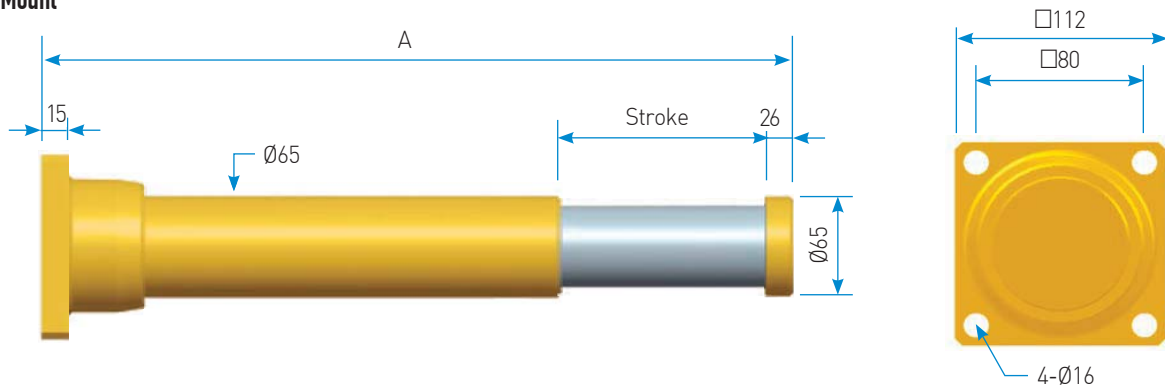

Front Mount

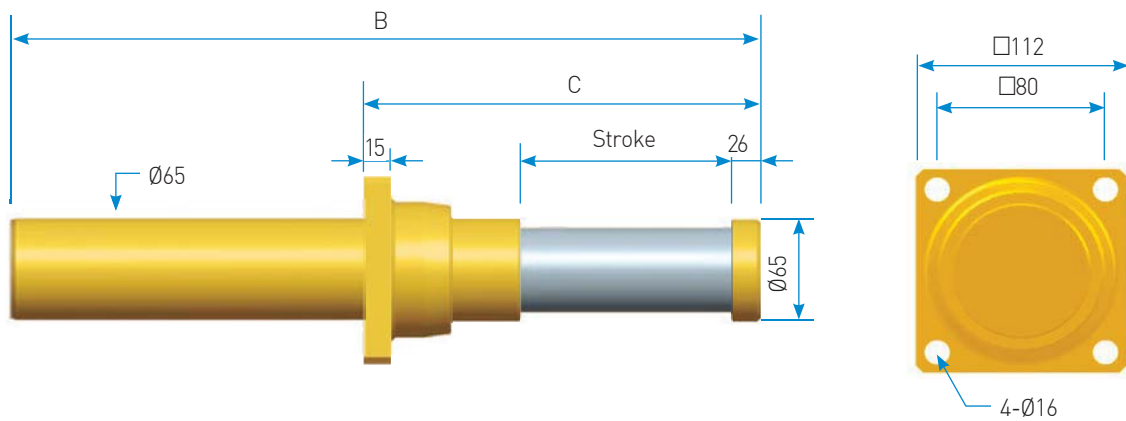

Dimensions

(unit : mm)

Model	Stroke (mm)	Rear Type (mm)			Front Type (mm)			Mounting Bolt Size
		A	B	C	A	B	C	
IBSG65 - 50	50	312	300	151			14	
- 75	75	372	360	176				
- 100	100	432	420	231				
- 150	150	552	540	281				
- 200	200	682	670	371				

Engineering Data

Model	Stroke (mm)	Max.Energy / Cycle(kJ)	Max.Buffer Force (kJ)	Recoil Force (kN)		Weight(kg)
				Ext.	Comp.	
IBSG85 - 50	50	7.5	188	1.5	13	12
- 100	100	15	188	1.5	13	14
- 150	150	22.5	188	1.5	20	17
- 200	200	30	188	1.5	20	20
- 250	250	37.5	188	1.5	20	22

Rear Mount

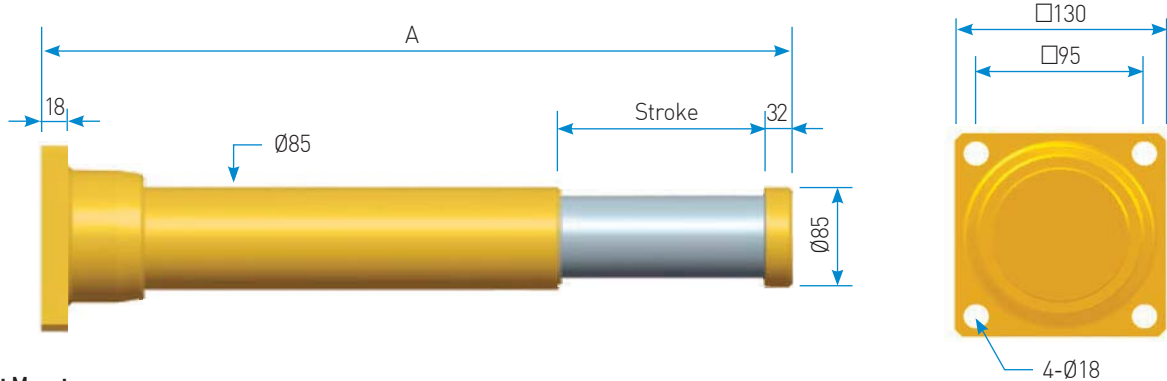

Front Mount

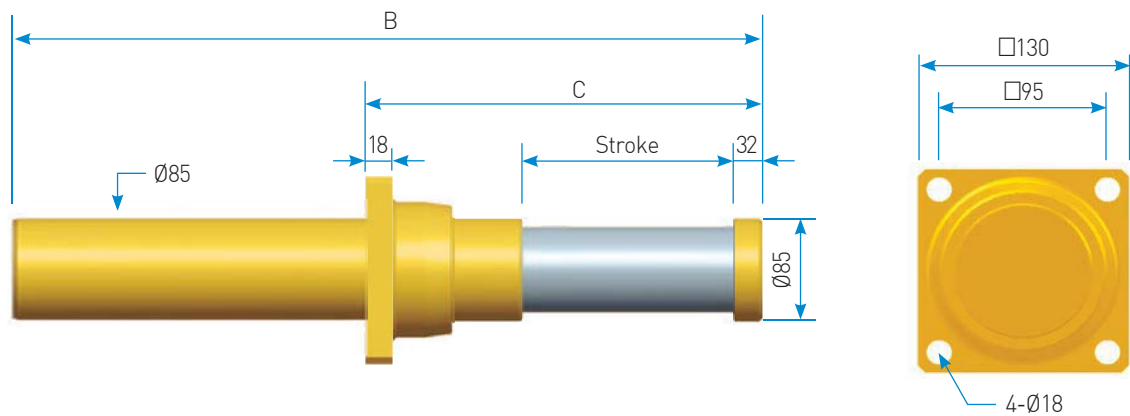

Dimensions

(unit : mm)

Model	Stroke (mm)	Rear Type (mm)		Front Type (mm)		Mounting Bolt Size
		A	B	C		
IBSG85 - 50	50	323	310	183	16	
- 100	100	463	450	242		
- 150	150	603	590	305		
- 200	200	743	730	367		
- 250	250	883	870	430		

IBSG100 Series

Engineering Data

Model	Stroke (mm)	Max.Energy / Cycle(kJ)	Max.Buffer Force (kJ)	Recoil Force (kN)		Weight(kg)
				Ext.	Comp.	
IBSG100 - 80	80	16	250	2.4	16	20
- 100	100	20	250	2.4	16	25
- 150	150	30	250	2.4	20	28
- 200	200	40	250	2.4	20	34
- 250	250	50	250	2.4	25	39
- 300	300	60	250	2.4	25	43

Rear Mount

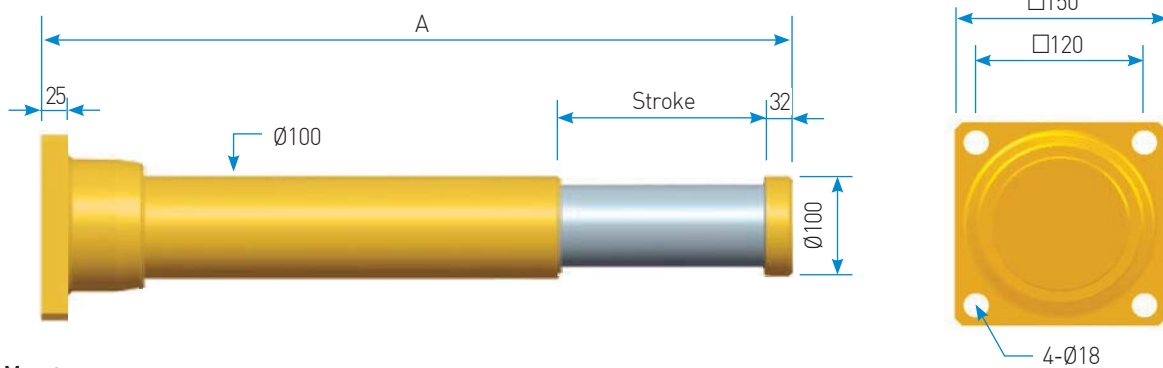

Front Mount

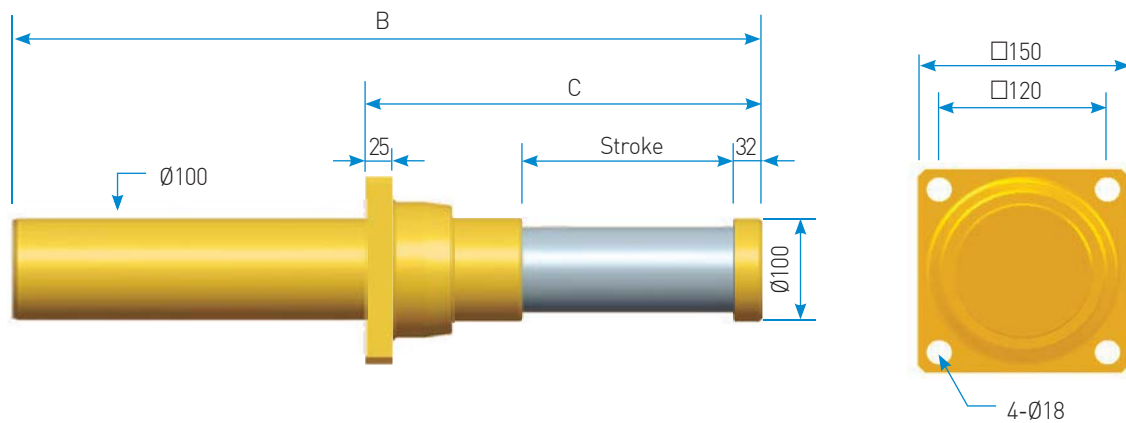

Dimensions

(unit : mm)

Model	Stroke (mm)	Rear Type (mm)			Front Type (mm)			Mounting Bolt Size
		A	B	C	B	C		
IBSG100 - 80	80	423	403	215			16	
- 100	100	450	430	252				
- 150	150	580	560	315				
- 200	200	720	700	377				
- 250	250	865	845	440				
- 300	300	1010	990	502				



Engineering Data

Model	Stroke (mm)	Max.Energy / Cycle(kJ)	Max.Buffer Force (kJ)	Recoil Force (kN)		Weight(kg)
				Ext.	Comp.	
IBSG120 - 100	100	40	500	3.5	40	41
- 150	150	60	500	3.5	40	48
- 200	200	80	500	3.5	40	58
- 250	250	100	500	3.5	40	65
- 300	300	120	400	3.5	40	72
- 400	400	160	400	3.5	40	78
- 500	500	180	400	3.5	40	86
- 600	600	200	400	3.5	40	95
- 800	800	240	375	3.5	40	112
- 1000	1000	280	350	3.5	40	118

Rear Mount

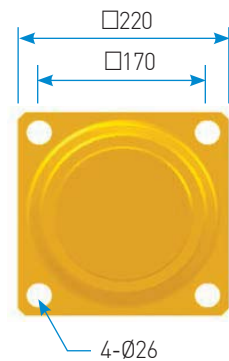
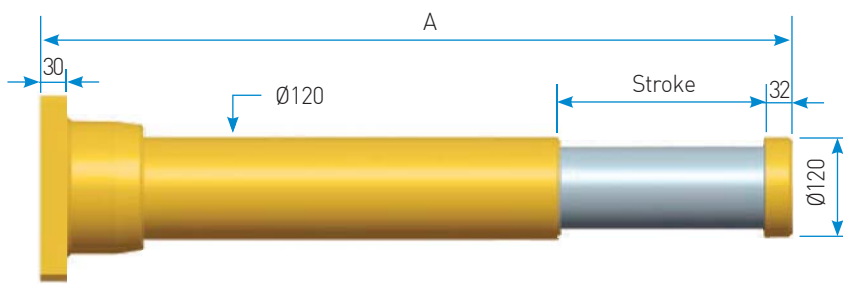

Front Mount

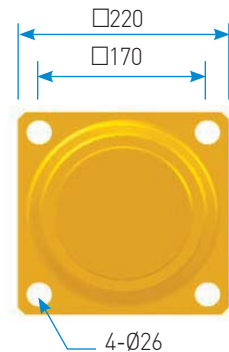
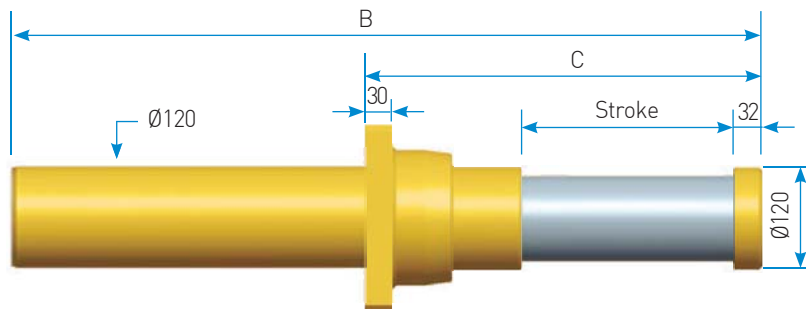

Dimensions

(unit : mm)

Model	Stroke (mm)	Rear Type (mm)		Front Type (mm)		Mounting Bolt Size
		A	B	C		
IBSG120 - 100	100	470	450	277	24	
- 150	150	610	590	340		
- 200	200	760	740	402		
- 250	250	900	880	465		
- 300	300	1050	1030	527		
- 400	400	1340	1320	680		
- 500	500	1620	1600	815		
- 600	600	1920	1900	950		
- 800	800	-	2400	1290		
- 1000	1000	-	2960	1360		

IBSG140 Series

Best engineered
for energy absorption
technology

Engineering Data

Model	Stroke (mm)	Max.Energy / Cycle(kJ)	Max.Buffer Force (kJ)	Recoil Force (kN)		Weight(kg)
				Ext.	Comp.	
IBSG140 - 100	100	55	688	6	70	60
- 200	200	110	688	6	70	85
- 300	300	165	688	6	70	110
- 400	400	220	688	6	78	135
- 500	500	270	680	6	78	150
- 600	600	300	630	6	78	160
- 800	800	325	510	6	78	185
- 1000	1000	360	450	6	78	200

Rear Mount

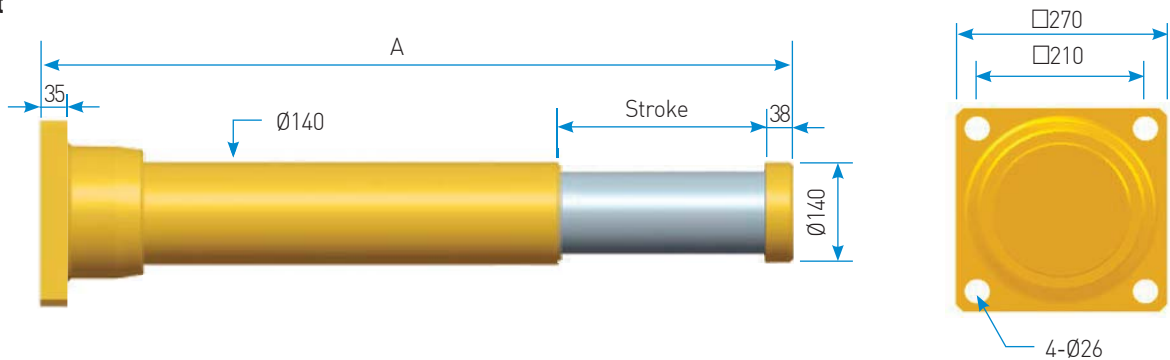

Front Mount

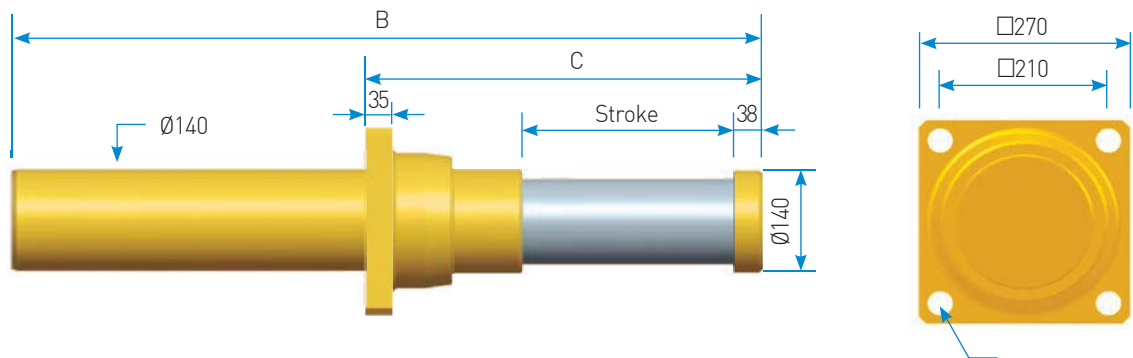

Dimensions

(unit : mm)

Model	Stroke (mm)	Rear Type (mm)		Front Type (mm)		Mounting Bolt Size
		A	B	C		
IBSG140 - 100	100	480	460	297	24	
- 200	200	770	750	422		
- 300	300	1060	1040	547		
- 400	400	1350	1330	712		
- 500	500	1630	1610	847		
- 600	600	1930	1910	982		
- 800	800	2350	2330	1252		
- 1000	1000	-	2880	1595		

IBAW Series Stacker Crane Buffers

NEW

DESCRIPTION

IBAW is newly launched state-of-the-art dial type buffer which is engineered to select damping forces against wide application conditions. Engineered to maintain rather low peak figures & rebounding forces. Therefore it can be operated by lowest rebounding force and decelerate softly in emergency stop conditions. Used for mainly stacker crane application in automated logistic system, dial type has models upto 300mm stroke and maximum energy 376 kJ, there are front dial control type & back dial control type according to the dial location.

FEATURES

- 1 Customized orifice
- 2 Piston rod surface treatment : Hardened, Hard chrome plated
- 3 Body surface treatment : White zinc plated
- 4 Operation temperature : -10 ~ 80°C • Special : -40 ~ 120°C
- 5 Fullfilled international standards : OSHA, AISE,AIST, CMAA, DIN, FEM etc.
- 6 Option : Urethane cap, Safety cable, Mounting plates, Adjustment dial position

APPLICATION

Automatic warehouse stacker crane, logistic automation system, amusement park, STS crane, production facilities.



Hydraulic Buffers

IBAW Series

IBAW SERIES ORDERING INFORMATION

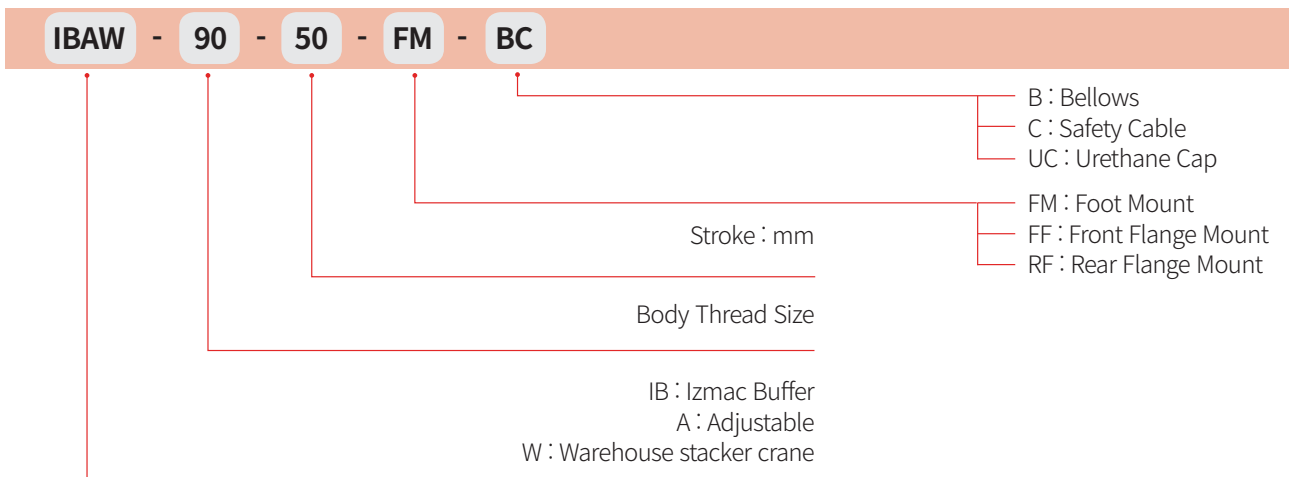

IBAW90 Series

Engineering Data

Model	Stroke (mm)	Max. Energy / Cycle(kJ) E_T	Max. Energy / Hour(kJ/hr) $E_T C$	Dimension [unit:mm]							
				A	B	C	D	E	F	G	H
IBAW90 - 50	50	3	77	300	218	90	30	58	250	66	20
- 100	100	6	77	400	268	90	30	58	300	116	20
- 150	150	9	77	500	318	90	30	58	350	166	20
- 200	200	12	77	600	368	90	30	58	400	216	20
- 250	250	15	77	700	418	90	30	58	450	266	20
- 300	300	18	77	800	468	90	30	58	500	316	20

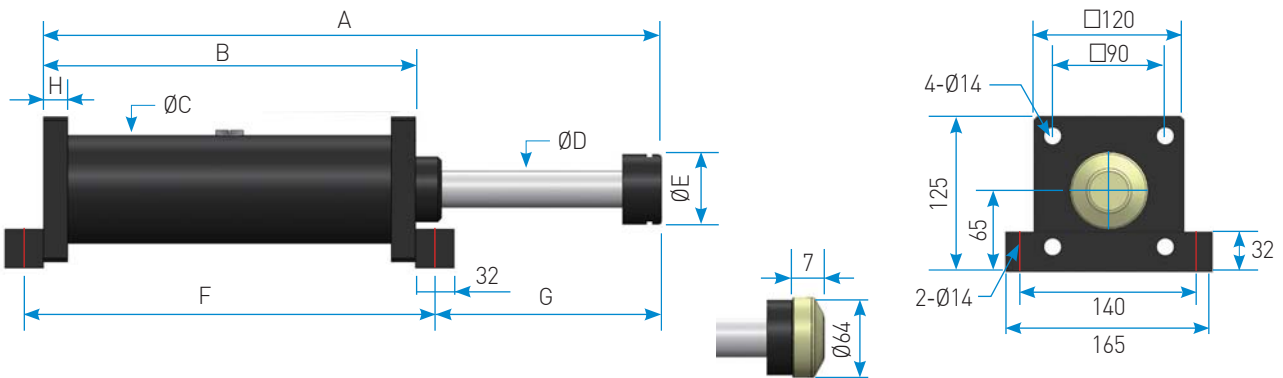

IBAW110 Series

Engineering Data

Model	Stroke (mm)	Max. Energy / Cycle(kJ) E_T	Max. Energy / Hour(kJ/hr) $E_T C$	Dimension [unit:mm]							
				A	B	C	D	E	F	G	H
IBAW110 - 50	50	4	114	320	230	110	35	58	270	70	25
- 100	100	9	114	420	280	110	35	58	320	120	25
- 150	150	13	114	520	330	110	35	58	370	170	25
- 200	200	18	114	620	380	110	35	58	420	220	25
- 250	250	23	114	720	430	110	35	58	470	270	25
- 300	300	27	114	820	480	110	35	58	520	320	25

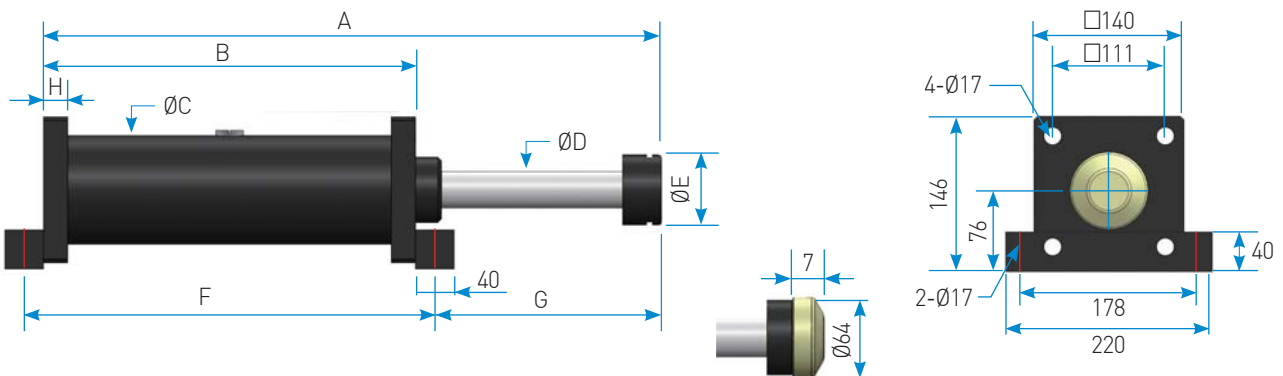

IBAW130 Series

Best engineered
for energy absorption
technology

Engineering Data

Model	Stroke (mm)	Max. Energy / Cycle(kJ) E_T	Max. Energy / Hour(kJ/hr) $E_{T,C}$	Dimension [unit:mm]							
				A	B	C	D	E	F	G	H
IBAW130 - 50	50	8	210	350	250	138	45	58	300	75	25
- 75	75	16	210	450	300	138	45	58	350	125	25
- 125	125	25	210	550	350	138	45	58	400	175	25
- 200	200	33	210	650	400	138	45	58	450	225	25
- 250	250	42	210	750	450	138	45	58	500	275	25
- 300	300	50	210	850	500	138	45	58	550	325	25

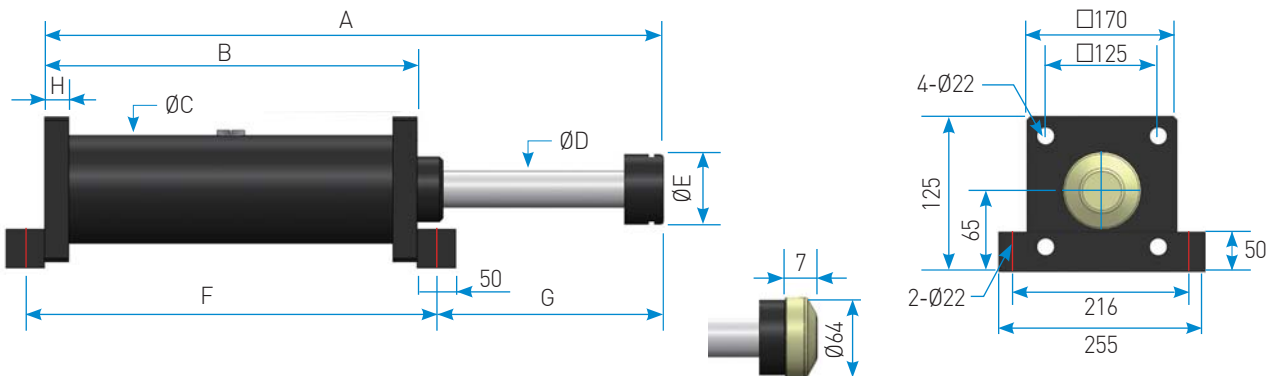

IBAW160 Series

Engineering Data

Model	Stroke (mm)	Max. Energy / Cycle(kJ) E_T	Max. Energy / Hour(kJ/hr) $E_{T,C}$	Dimension [unit:mm]							
				A	B	C	D	E	F	G	H
IBAW160 - 50	50	10	267	380	280	160	50	98	330	75	25
- 100	100	21	267	480	330	160	50	98	380	125	25
- 150	150	32	267	580	380	160	50	98	430	175	25
- 200	200	42	267	680	430	160	50	98	480	225	25
- 250	250	53	267	780	480	160	50	98	530	275	25
- 300	300	64	267	880	530	160	50	98	580	325	25

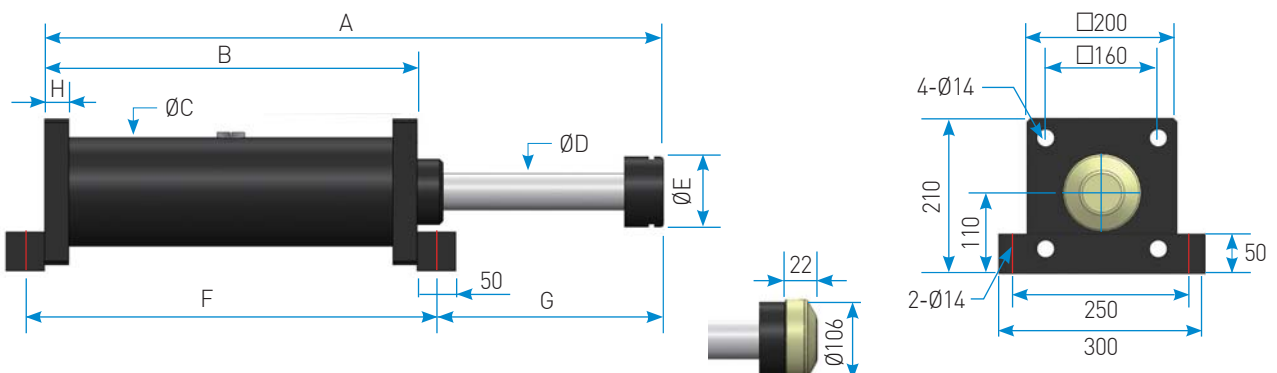

IBAW180 Series

Best engineered
for energy absorption
technology

Engineering Data

Model	Stroke (mm)	Max. Energy / Cycle(kJ) E_T	Max. Energy / Hour(kJ/hr) $E_T C$	Dimension [unit:mm]							
				A	B	C	D	E	F	G	H
IBAW180 - 50	50	13	338	440	340	180	55	98	390	75	40
- 100	100	27	338	540	390	180	55	98	440	125	40
- 150	150	40	338	640	440	180	55	98	490	175	40
- 200	200	54	338	740	490	180	55	98	540	225	40
- 250	250	67	338	840	540	180	55	98	590	275	40
- 300	300	81	338	940	590	180	55	98	640	325	40

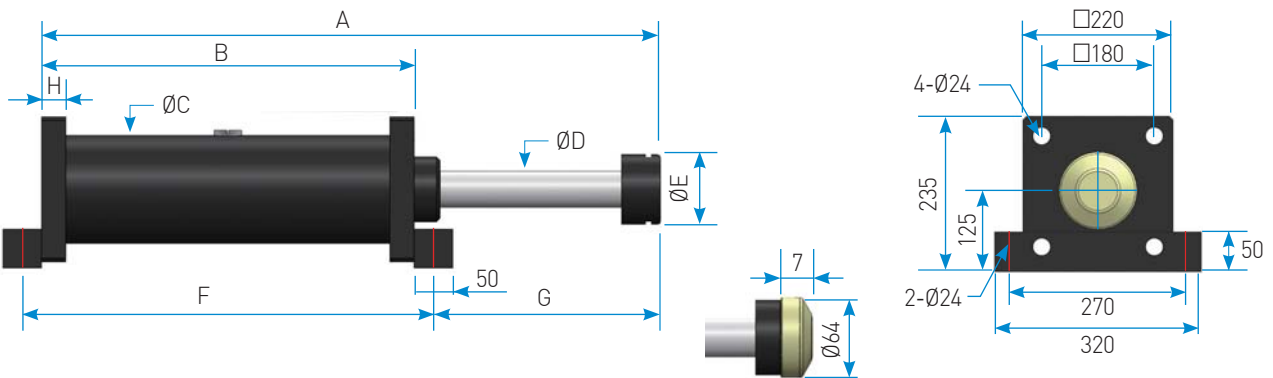

IBAW200 Series

Engineering Data

Model	Stroke (mm)	Max. Energy / Cycle(kJ) E_T	Max. Energy / Hour(kJ/hr) $E_T C$	Dimension [unit:mm]							
				A	B	C	D	E	F	G	H
IBAW200 - 50	50	15	376	450	350	200	65	98	400	75	40
- 100	100	30	376	550	400	200	65	98	450	125	40
- 150	150	45	376	650	450	200	65	98	500	175	40
- 200	200	60	376	750	500	200	65	98	550	225	40
- 250	250	75	376	850	550	200	65	98	600	275	40
- 300	300	90	376	950	600	200	65	98	650	325	40

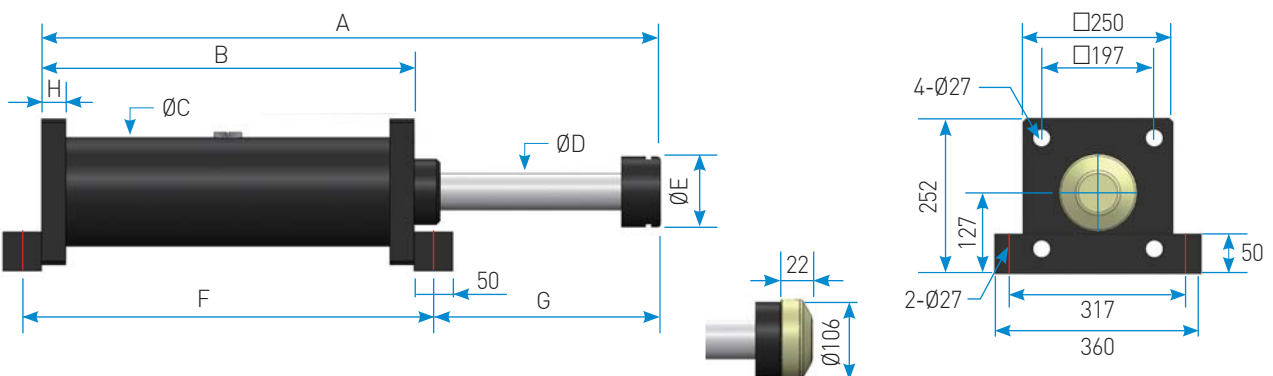

IBSW Series Stacker Crane Buffers

Izmac Buffer Self compensating auto Warehouse stackercrane

DESCRIPTION

IBSW model max energy capacity is upto 915kJ, and it's longest stroke is 1,200mm and it is mainly applied for automatic logistic warehouse system(AS/RS). Engineered to maintain rather Low Peak figures & Low Recoil Force figures. Therefore it can be operated by lowest rebounding force and decelerate softly in emergency stop conditions. Basically IBSW has similar operation way with ISAA series.

FEATURES

- 1 Custom orifice
- 2 Piston rod : Hardened, hard chrome plated
- 3 Cylinder : Zinc plated
- 4 Operation temperature : -10 ~ 80°C • Special : -40 ~ 120°C
- 5 Fullfilled international standards : OSHA, AISE,AIST, CMAA, DIN, FEM etc.
- 6 Option : Urethane cap, Safety cable, Mounting plates

APPLICATION

Automatic warehouse system(AS/RS), Theme park, Stacker crane, Automobile assembly line, Overhead crane



Hydraulic Buffers

IBSW Series

IBSW SERIES ORDERING INFORMATION

IBSW - 90 - 250 - FM - BC

- B : Bellows
 - C : Safety Cable
 - UC : Urethane Cap
 - FM : Foot Mount
 - FF : Front Flange Mount
 - RF : Rear Flange Mount
- Stroke(mm)
- Body Thread Size
- IB : Izmac Buffer
S : Self Compensating
W : Warehouse stacker crane

IBSW90 Series

■ Engineering Data & Dimensions

Model	Stroke (mm)	Max. Energy / Cycle (kJ) E_T	Max. Energy / Hour (kJ/hr) E_{TC}	Max. Buffer Force (kN) F_S	Dimension [unit:mm]							
					A	B	C	D	E	F	G	H
IBSW90 - 50	50	4	190	75	310	208	90	30	50	240	86	20
- 100	100	7	390	75	410	258	90	30	50	290	136	20
- 150	150	10	580	75	510	308	90	30	50	340	186	20
- 200	200	13	780	75	613	360	90	30	50	392	237	20
- 250	250	16	830	75	715	411	90	30	50	443	288	20
- 300	300	20	940	75	817	462	90	30	50	496	339	20
- 350	350	23	1,260	75	918	512	90	30	50	544	390	20
- 400	400	21	1,150	67	1,019	563	90	30	50	595	440	20
- 450	450	20	1,090	55	1,121	614	90	30	50	646	491	20
- 500	500	19	1,060	47	1,223	665	90	30	50	697	542	20
- 600	600	15	880	31	1,427	767	90	30	50	799	644	20
- 700	700	13	610	24	1,668	910	90	30	50	956	742	20
- 800	800	12	530	19	1,888	1,030	90	30	50	1,076	842	20

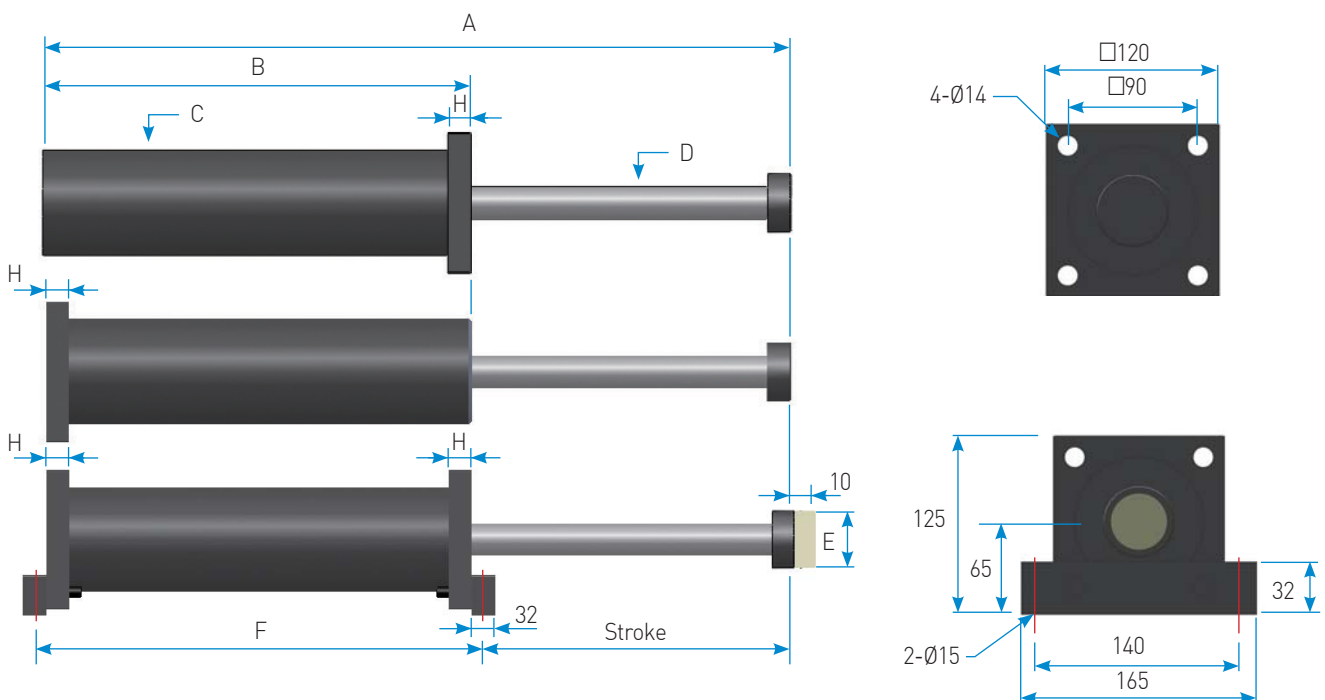

■ Engineering Data & Dimensions

Model	Stroke (mm)	Max. Energy / Cycle (kJ) E_T	Max. Energy / Hour (kJ/hr) $E_{T,C}$	Max. Buffer Force (kN) F_S	Dimension [unit:mm]							
					A	B	C	D	E	F	G	H
IBSW110 - 50	50	5	290	115	370	203	Ø110	40	60	270	120	25
- 100	100	10	560	115	470	280	Ø110	40	60	320	170	25
- 150	150	15	880	115	553	339	Ø110	40	60	379	194	25
- 200	200	20	930	115	655	390	Ø110	40	60	430	245	25
- 250	250	25	1,050	115	757	441	Ø110	40	60	481	296	25
- 300	300	29	1,180	115	859	492	Ø110	40	60	532	347	25
- 350	350	34	1,350	115	960	543	Ø110	40	60	583	397	25
- 400	400	39	1,510	115	1,062	594	Ø110	40	60	634	448	25
- 450	450	44	1,680	115	1,164	645	Ø110	40	60	685	499	25
- 500	500	49	1,840	115	1,265	695	Ø110	40	60	735	550	25
- 600	600	59	2,160	115	1,469	797	Ø110	40	60	837	652	25
- 700	700	69	2,480	115	1,672	899	Ø110	40	60	937	753	25
- 800	800	79	2,800	115	1,953	1,079	Ø110	40	60	1,119	854	25
- 900	900	88	3,130	115	2,151	1,179	Ø110	40	60	1,219	952	25
- 1000	1000	73	3,480	92	2,351	1,279	Ø110	40	60	1,319	1,052	25
- 1200	1200	60	2,750	63	2,751	1,479	Ø110	40	60	1,519	1,252	25
- 1400	1400	41	1,910	37	3,171	1,689	Ø110	40	60	1,729	1,462	25

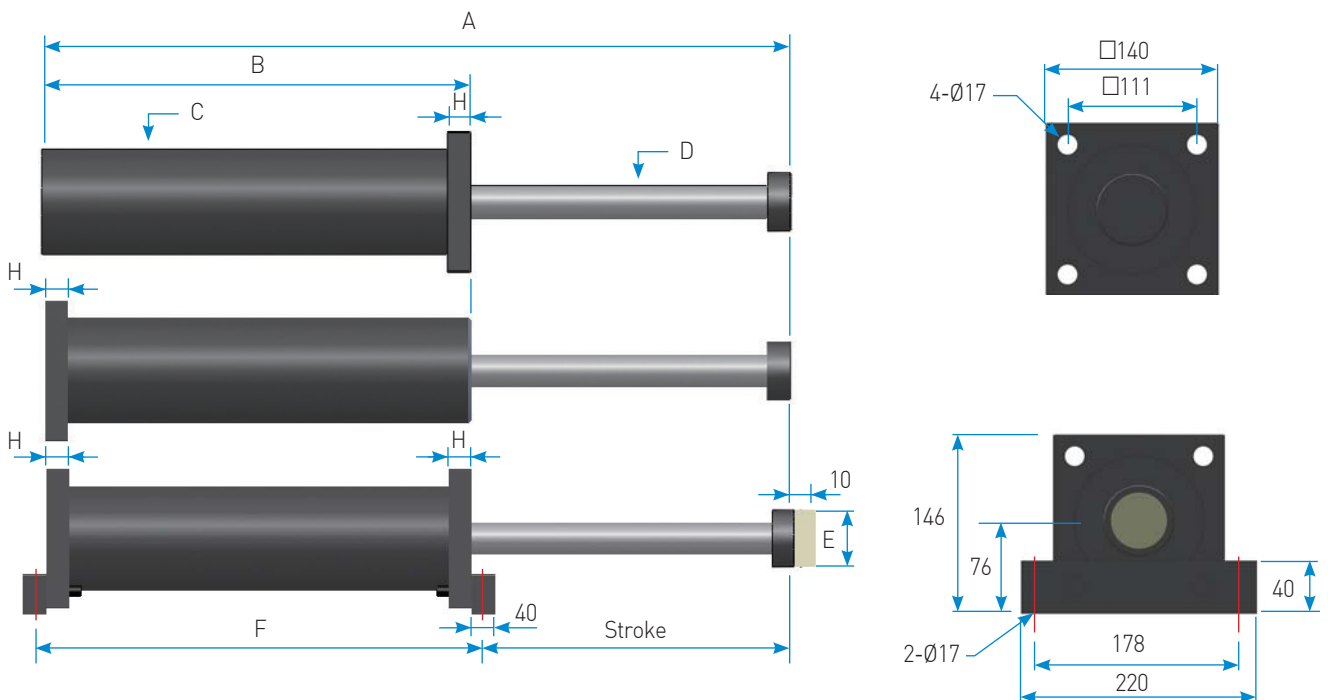

IBSW130 Series

■ Engineering Data & Dimensions

Model	Stroke (mm)	Max. Energy / Cycle (kJ) E_T	Max. Energy / Hour (kJ/hr) $E_{T,C}$	Max. Buffer Force (kN) F_S	Dimension [unit:mm]							
					A	B	C	D	E	F	G	H
IBSW130 - 50	50	10	590	245	336	260	138	45	70	310	112	25
-75	75	15	650	245	387	285	138	45	70	335	137	25
-125	125	25	810	245	489	335	138	45	70	385	187	25
-200	200	39	1,110	245	640	410	138	45	70	460	262	25
-250	250	49	1,310	245	742	460	138	45	70	510	312	25
-300	300	58	1,510	245	844	511	138	45	70	561	362	25
-350	350	68	1,730	245	995	558	138	45	70	608	412	25
-400	400	78	1,930	245	1,097	609	138	45	70	659	463	25
-450	450	88	2,130	245	1,199	660	138	45	70	710	514	25
-500	500	97	2,320	245	1,301	711	138	45	70	761	565	25
-600	600	116	2,710	245	1,504	812	138	45	70	862	667	25
-700	700	136	3,100	245	1,707	914	138	45	70	964	768	25
-800	800	155	3,480	215	1,910	1,015	138	45	70	1,065	870	25
-900	900	167	3,780	181	2,156	1,164	138	45	70	1,214	967	25
-1000	1,000	117	3,820	147	2,356	1,264	138	45	70	1,314	1,067	25
-1200	1,200	103	4,720	107	2,756	1,464	138	45	70	1,514	1,267	25
-1400	1,400	73	2,850	66	3,156	1,664	138	45	70	1,714	1,467	25
-1500	1,500	66	2,430	55	3,384	1,778	138	45	70	1,828	1,581	25

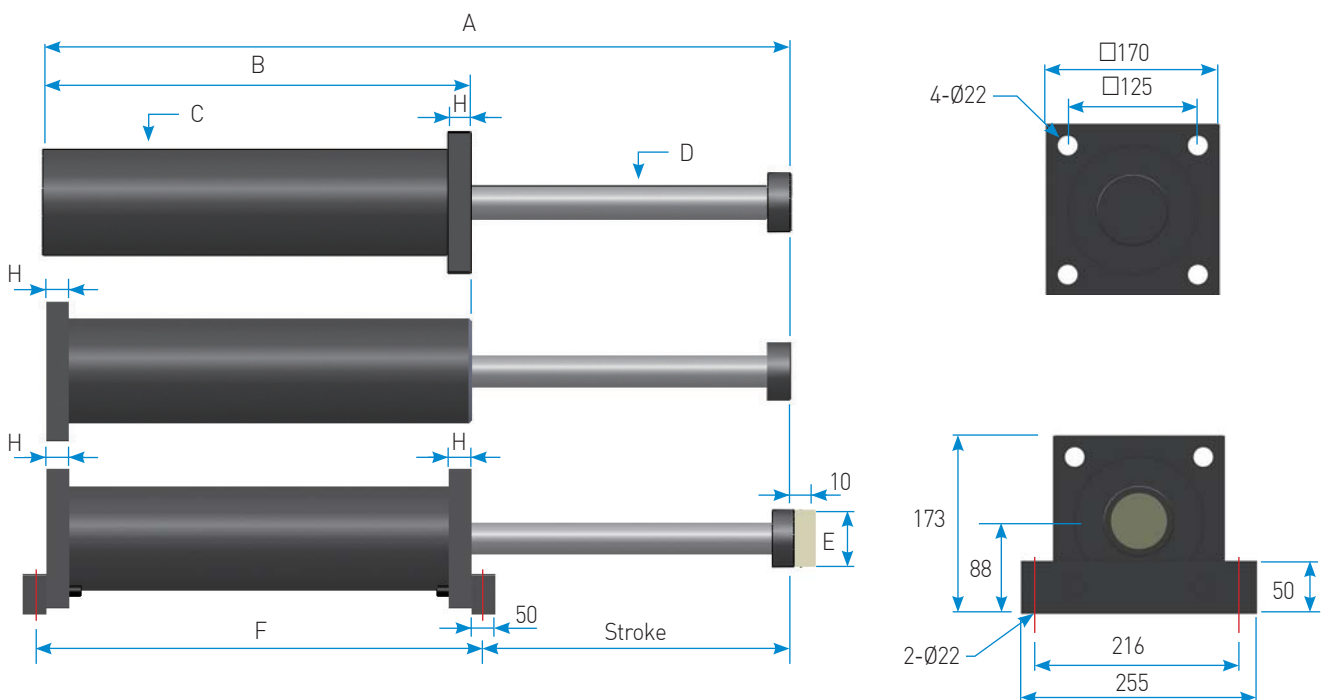



Engineering Data & Dimensions

Model	Stroke (mm)	Max. Energy / Cycle (kJ) E_T	Max. Energy / Hour (kJ/hr) $E_{T,C}$	Max. Buffer Force (kN) F_S	Dimension [unit:mm]							
					A	B	C	D	E	F	G	H
IBSW200 - 50	50	16	940	370	430	394	200	65	100	444	115	40
- 100	100	31	1,530	370	532	445	200	65	100	495	164	40
- 150	150	47	1,750	370	632	495	200	65	100	545	215	40
- 200	200	63	1,980	370	735	547	200	65	100	597	263	40
- 250	250	79	2,210	370	836	597	200	65	100	647	314	40
- 300	300	93	2,850	370	1,032	642	200	65	100	692	365	40
- 400	400	126	3,300	370	1,234	743	200	65	100	793	466	40
- 500	500	157	3,750	370	1,438	845	200	65	100	895	568	40
- 600	600	188	4,210	370	1,642	947	200	65	100	997	670	40
- 700	700	220	4,660	370	1,844	1,048	200	65	100	1,098	771	40
- 800	800	251	5,110	370	2,048	1,150	200	65	100	1,200	873	40
- 900	900	283	5,560	370	2,252	1,252	200	65	100	1,302	975	40
- 1000	1,000	240	6,110	300	2,454	1,353	200	65	100	1,403	1,076	40
- 1200	1,200	210	4,920	200	2,854	1,553	200	65	100	1,603	1,276	40

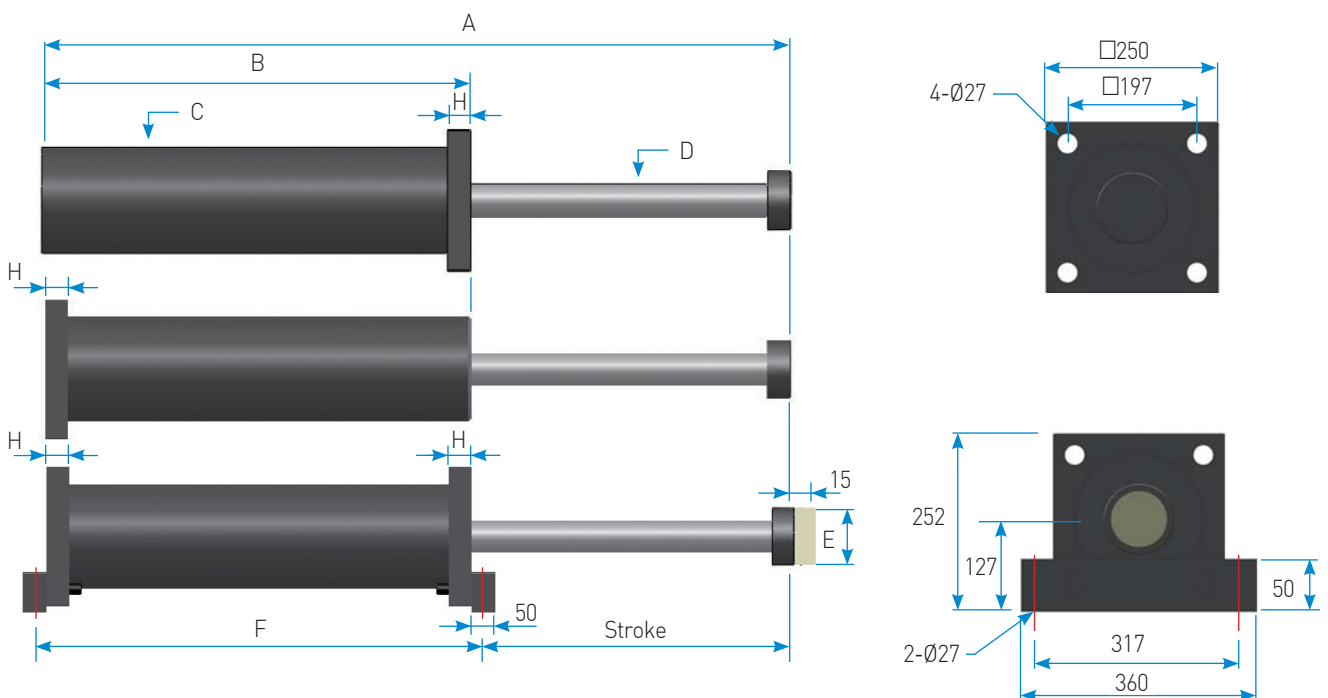

IBSW215 Series

■ Engineering Data & Dimensions

Model	Stroke (mm)	Max. Energy / Cycle (kJ) E_T	Max. Energy / Hour (kJ/hr) $E_{T,C}$	Max. Buffer Force (kN) F_S	Dimension [unit:mm]							
					A	B	C	D	E	F	G	H
IBSW215 - 100	100	48	1,800	560	591	375	215	80	125	435	186	40
- 150	150	72	2,050	560	693	426	215	80	125	486	237	40
- 200	200	96	2,290	560	795	477	215	80	125	537	288	40
- 250	250	120	2,530	560	895	527	215	80	125	587	338	40
- 300	300	143	2,750	560	997	578	215	80	125	638	389	40
- 400	400	191	3,260	560	1,201	680	215	80	125	740	491	40
- 500	500	239	4,230	560	1,504	882	215	80	125	942	592	40
- 600	600	287	4,740	560	1,708	984	215	80	125	1,044	694	40
- 700	700	334	5,200	560	1,910	1,085	215	80	125	1,145	795	40
- 800	800	382	5,690	560	2,114	1,187	215	80	125	1,247	897	40
- 1000	1,000	478	6,680	560	2,520	1,390	215	80	125	1,450	1,100	40
- 1200	1,200	417	6,250	435	2,920	1,590	215	80	125	1,650	1,300	40

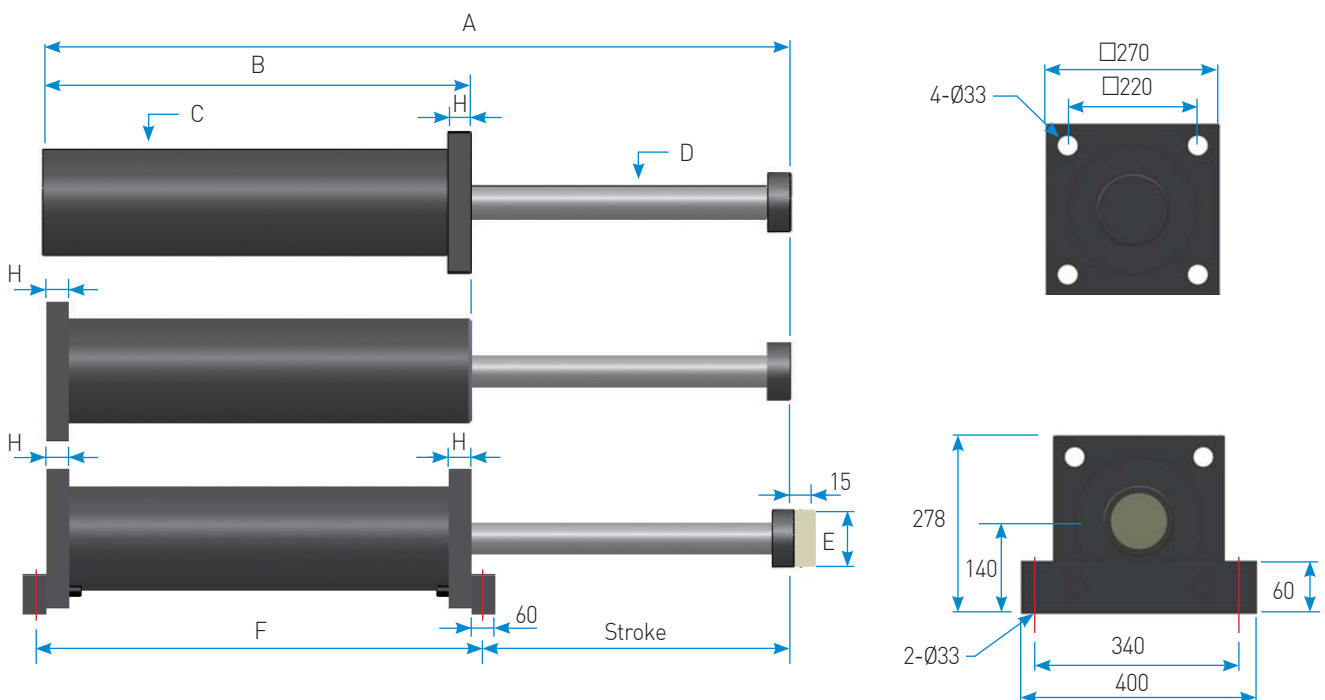



■ Engineering Data & Dimensions

Model	Stroke (mm)	Max. Energy / Cycle (kJ) E_T	Max. Energy / Hour (kJ/hr) $E_{T,C}$	Max. Buffer Force (kN) F_S	Dimension [unit:mm]							
					A	B	C	D	E	F	G	H
IBSW275 - 100	100	78	2,440	915	637	391	275	100	160	461	211	50
- 150	150	117	2,760	915	737	441	275	100	160	511	261	50
- 200	200	156	3,050	915	839	492	275	100	160	562	312	50
- 250	250	194	3,370	915	941	543	275	100	160	613	363	50
- 300	300	233	3,760	915	1,043	594	275	100	160	664	414	50
- 400	400	311	4,300	915	1,246	696	275	100	160	766	515	50
- 500	500	389	4,930	915	1,450	798	275	100	160	868	617	50
- 600	600	467	6,180	915	1,769	1,015	275	100	160	1,085	719	50
- 750	750	583	7,110	915	2,073	1,167	275	100	160	1,237	871	50
- 900	900	700	8,040	915	2,379	1,320	275	100	160	1,390	1,024	50
- 1050	1,050	816	8,970	915	2,683	1,472	275	100	160	1,542	1,176	50
- 1200	1,200	790	8,060	827	2,989	1,625	275	100	160	1,695	1,329	50

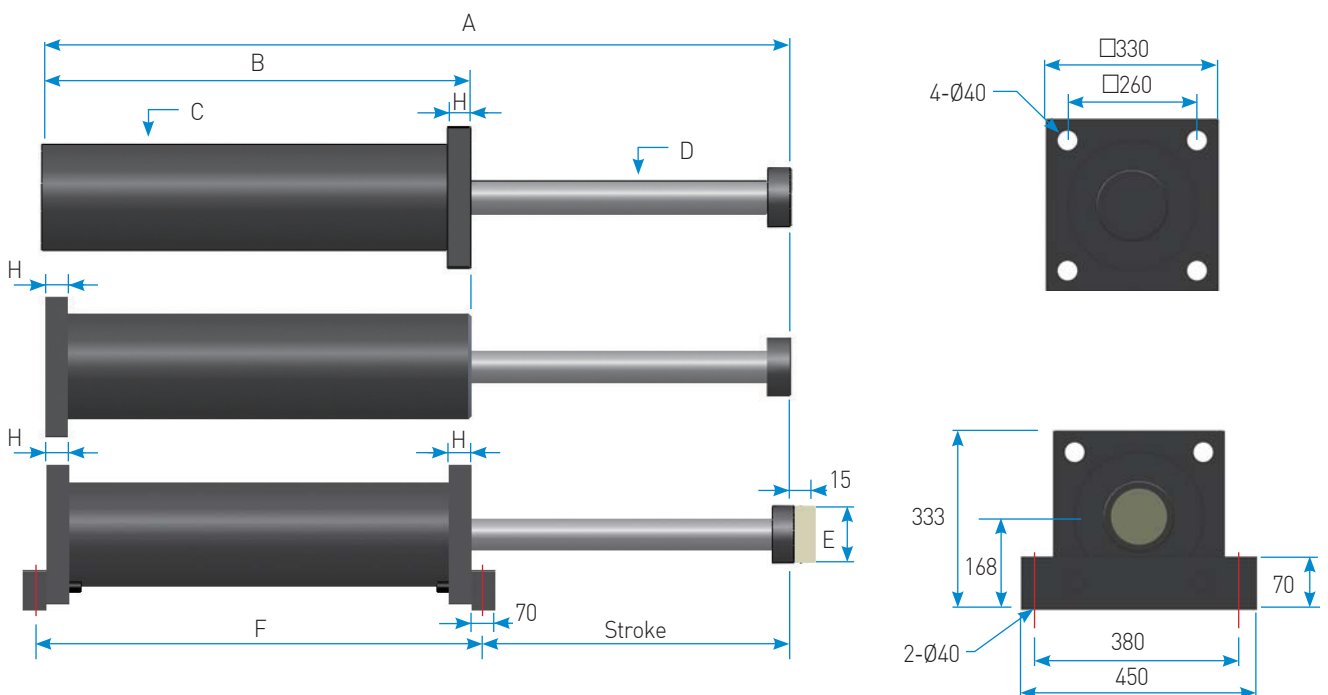

Damper & Rate Control

ISAA Series Speed Control

NEW

Izmac Speed control Adjustable Absorption

DESCRIPTION

ISAA is an absorption function added product that absorbs the initial collision of the existing product, in addition to the capability of precise speed control according to the control range, it is possible to control the constant speed of various weights according to the stroke, so it protects the equipment and extends the life of the machine tool.



- Process

- ① Step1 : shock absorption
- ② Step2 : Control same speed

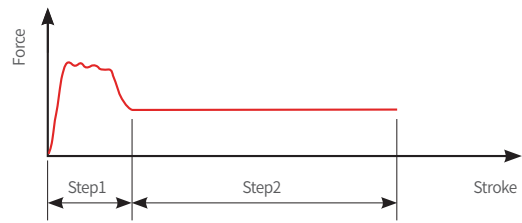

FEATURES

- 1 The device enables easy control precise speed according to 30 steps of adjustment Knob.
- 2 It can be installed simply by using snap ring mounting block, and it can be changed the location also. In addition it can be fixed easily.
- 3 Oil is internally filtered by itself, and speed is controlled always at the same speed.
- 4 Application : Auto feed drilling, Cutting machine, Grinding machine, Boring machine, Sawing machine etc. Which requires same speed control.
- 5 Application temperature : Standard (-10~80°C)
 - Special (-30~100°C)
- 6 Accurate two step speed control

APPLICATION

Widely used where speed control is required, such as drilling, cutting, safety devices, and drilling machines.

ISAA SERIES ORDERING INFORMATION

ISAA - 24 - 13 - B - SO

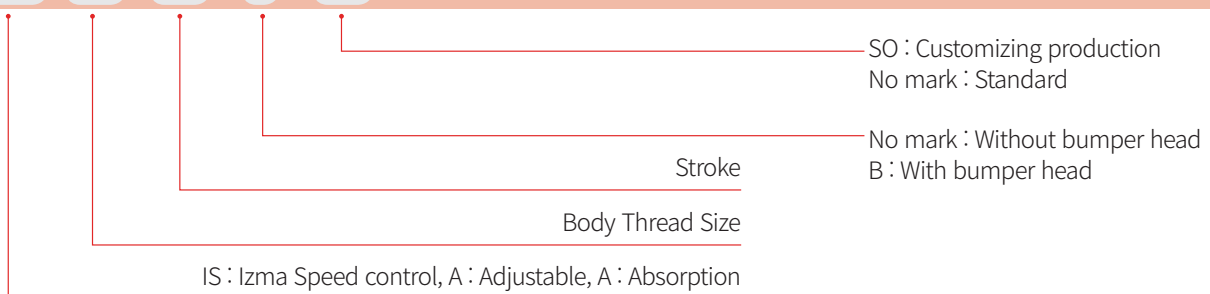



Engineering Data

Model	Damping Range [mm] Step1	Stroke [mm] Step2	Dimensions [mm]				Max. Load Angle [°]	Speed Adjustment Range		Weight (g)
			A	B	C	D		Load Limits [N]	Feed Rate Limits [mm/s]	
ISAA24 - 13B	5	13	174	21		165.4	0.5			415
- 25B	5	25	213	19	26	204.4	1	100~3,000	0.2~30	465
- 51B	5	51	314	16		305.4	0.5			645

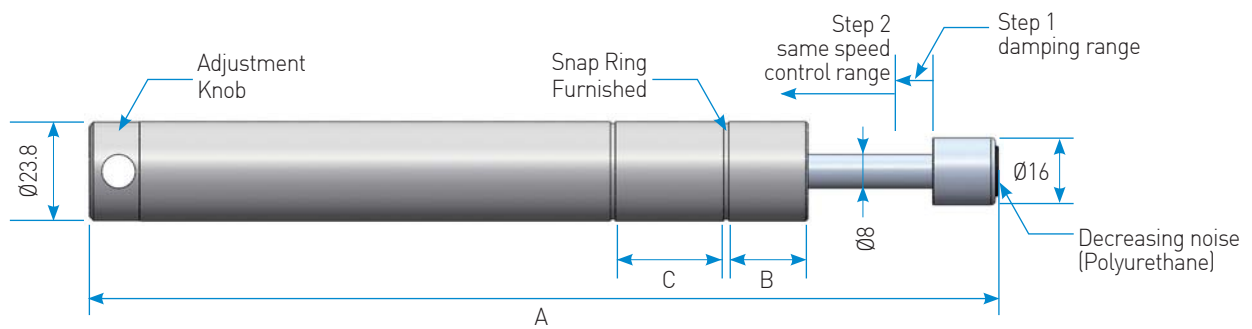

Steel head+Hard PU button
[B TYPE : Black]

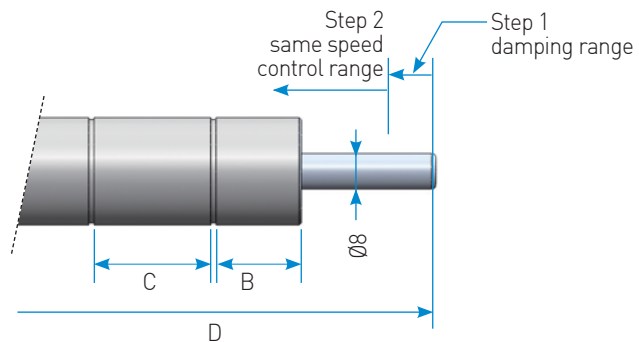

Mount Block

MB 24

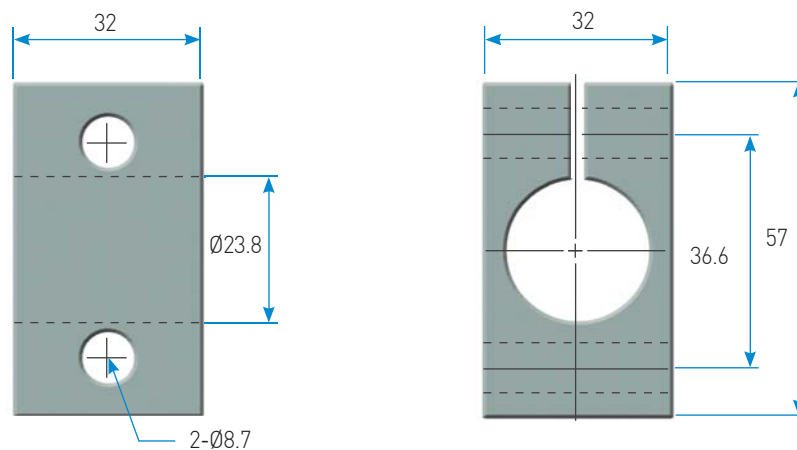

IDS Series Crash Damper

NEW

Izmac Damper Self compensating Multi step crash absorption

DESCRIPTION

IDS has multi-steps bumpy shape and it absorbs shock energy on collision moment with compressing step by step. Engineered to maintain rather low peak & recoil force.

FEATURES

- 1 Shock absorption response function is steady and absorption efficiency is high.
- 2 It has multi-steps bumpy shape and it absorb shock energy on collision moment with compressing step by step.
- 3 Compact (small and sturdy) and easy to handling.
- 4 Body surface strongly treated to prevent corrosion by nickel plating or alloy plating (black).
- 5 Various sizes, forces, strokes with customizing models are available.
- 6 Temperature range standard : -40 ~ 90°C



GRAPH

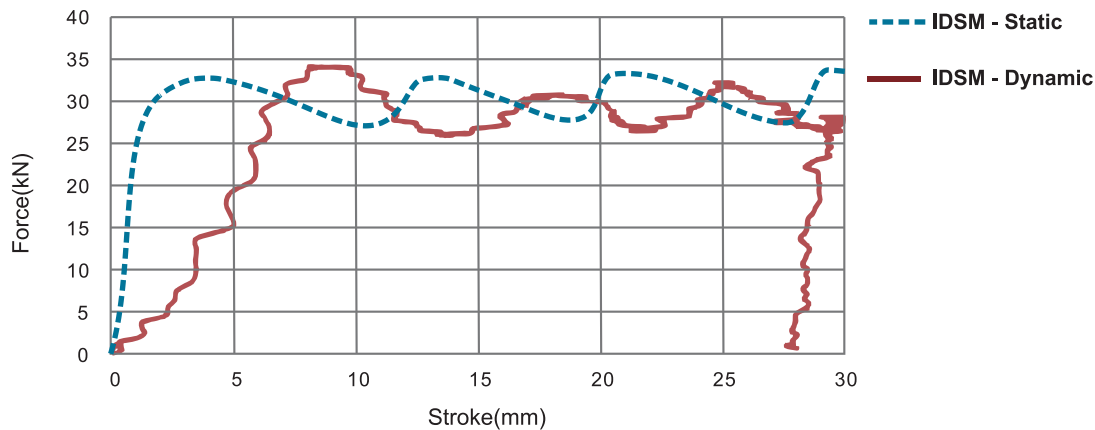

IDS SERIES ORDERING INFORMATION

IDS - 087 - 53

Nominal stroke

Tube outer diameter

ID : Izmac Damper
S : Self compensating
M : Multi step crash absorption



■ Dimensions & Engineering Data

Model	TD	ML	TL	Thread	stroke[mm]	Force[kN]	Energy[J]
IDS _M - 87 - 53	87.5	110	134.3	M10	53	30	1450
- 106	87.5	220	244	M10	105	30	2900

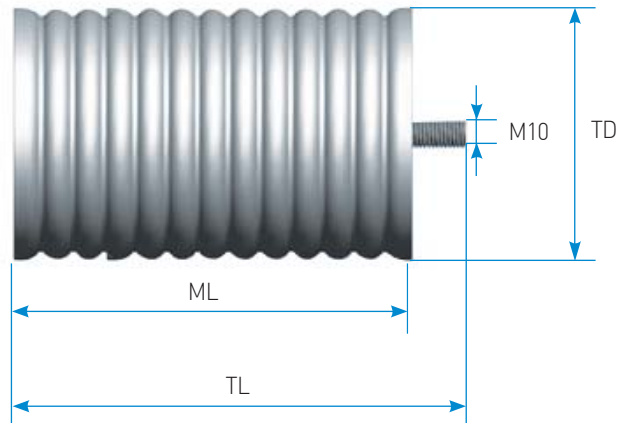

■ How to use

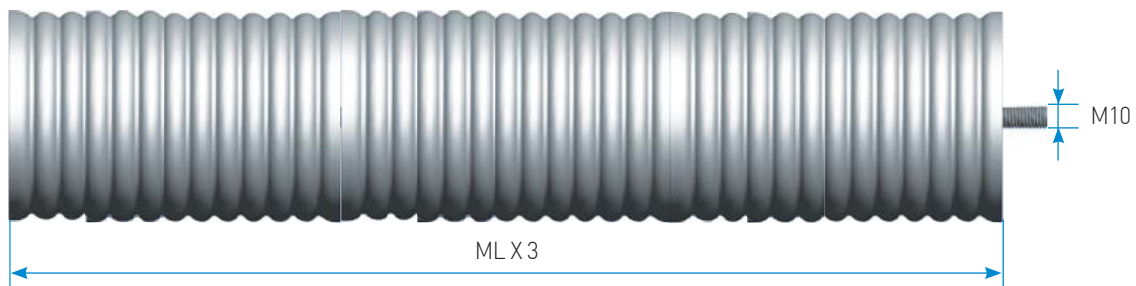
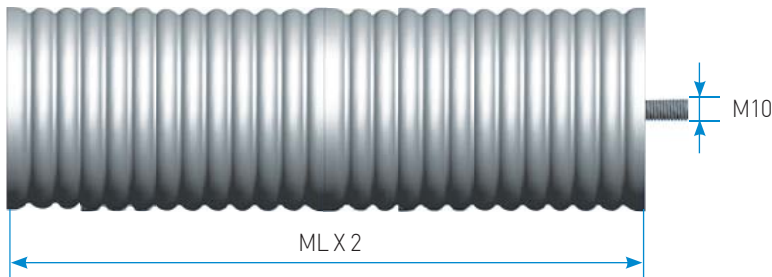

IDSP Series Crash Damper

NEW

Izmac Damper Self Plastic made

DESCRIPTION

IDSP is a disposable damping product that absorbs high energy by being made of heterogeneous engineering plastics, and it has a structure that converts kinetic energy from impact into deformation energy.

We provide damping solutions to meet the best performance in various industries. This product is suitable for emergency purpose.

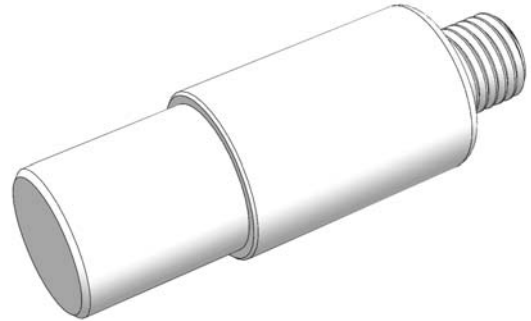

FEATURES

- 1 High deceleration performance.
- 2 Shock absorption response function is steady and absorption efficiency is high.
- 3 Low price, narrow space installation is available.
- 4 No maintenance required, no corrosion.
- 5 Customization is possible for various sizes, forces, strokes and capacities.
- 6 Operating temperature: -40~90°C

GRAPH

IDSP 2-038-030

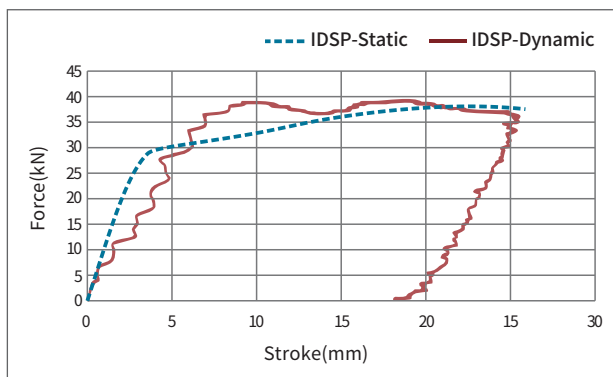

IDSP 2-034-030

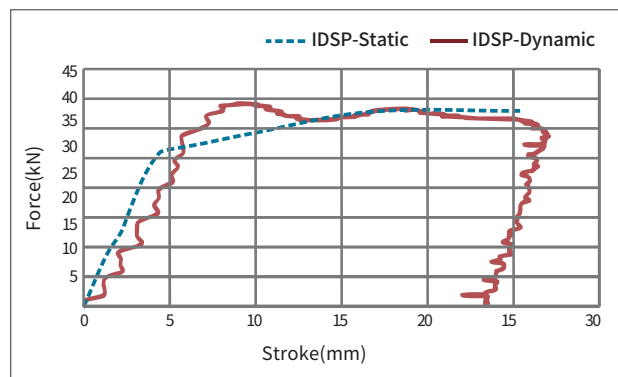

IDSP SERIES ORDERING INFORMATION

IDSP - 1 - 028 - 035

Nominal stroke

Tube outer diameter

Thread type(1 : threaded type, 2 : wrench bolt type)

ID : Izmac Damper

S : Self compensating

P : Plastic made damping



■ Dimensions & Engineering Data

Model	St [mm]	Fn[kN]	En[J]	TD[mm]	ML[mm]	M1[mm]	L1[mm]
IDSP-1-20-15	15	9.1	122.8	20	43.0	M12	10
-32-25	25	28.0	631	32	70.0	M16	15
-40-30	30	46.5	1255.4	40	85.0	M20	18
-52-40	40	82.9	2985.6	52	111.0	M30	25
-64-50	50	129.9	5,846.2	64	136.5	M36	30
IDSP-2-24-30	30	15.6	420.7	24	74.5	M8 x 1.25P	14.5
-34-30	30	34.8	940	34	79.0	M12 x 1.75P	18
-38-30	30	44.6	1204.3	38	81.0	M12 x 1.75P	21
-52-40	40	88.3	3180.6	52	108.0	M16 x 2.00P	19
-64-50	50	137.5	6,187.1	64	132.5	M20 x 2.50P	23.5

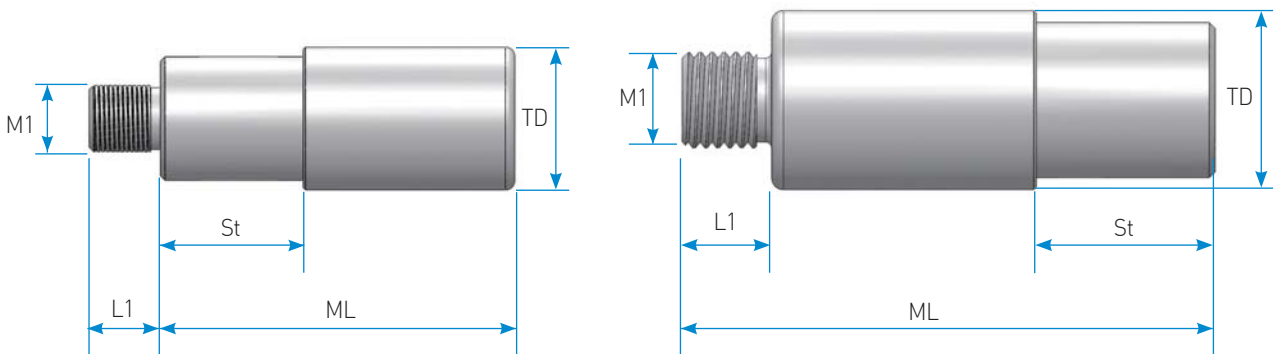

IRAD Series Rate Controls

NEW

Izmac Rate control Adjustable Double dial

DESCRIPTION

IRAD provides stable and accurate single directional/bi-directional speed control for the object when it moves from one position to another. This product is designed to set precise adjustment dial in 12 steps according to the user's application conditions. With speed control, you can significantly reduce shock and vibration to the machine due to uncontrolled & unexpected operation troubles.

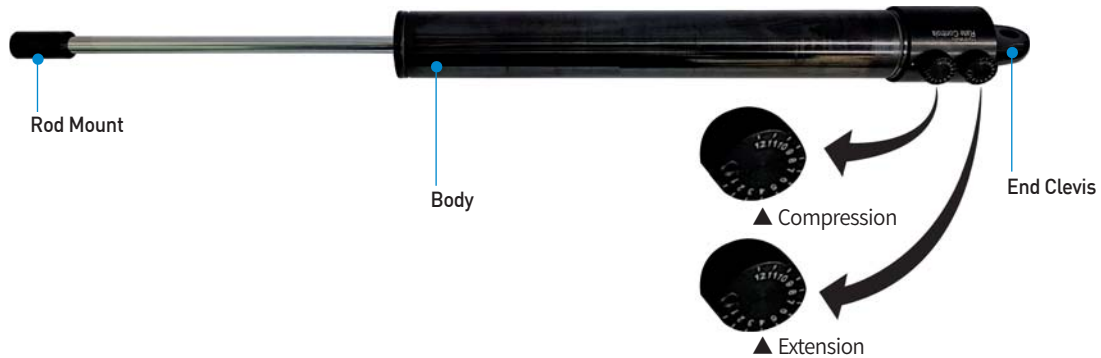

FEATURES

- 1 Maximum impact speed : 0.6m/s
- 2 Guarantees product life through perfect quality control.
- 3 Reinforced materials are used to enhance durability.
- 4 Perfect speed control : For safe machine operation and longer machine life
- 5 For safety device : Equipment cover (opene / close)
- 6 Operating temperature : Standard (-10~80°C) • Special (-30~100°C)

APPLICATION

Automotive , mechanical engineering, electronics industries.

IRAD SERIES ORDERING INFORMATION

IRAD - 30 - 50 - EC

E(Extension)
C(Compression)
EC(Both Sided)

Stroke

Body Thread Size

IR : Izmac Rate control
A : Adjustable
D : Double dial



■ Dimensions & Engineering Data

Model	Stroke (mm) s	Max. Propelling Force (N)		Weight (g)	Dimensions (mm)			Direction
		Ext	Comp		A	B	C	
IRAD30 - 50	50	3,000	3,000	310	250	200	176	E,C,E&C
- 100	100	3,000	2,600	380	350	250	226	E,C,E&C
- 150	150	3,000	2,100	450	450	300	276	E,C,E&C
- 200	200	3,000	1,400	530	550	350	326	E,C,E&C
- 250	250	3,000	800	600	650	400	376	E,C,E&C

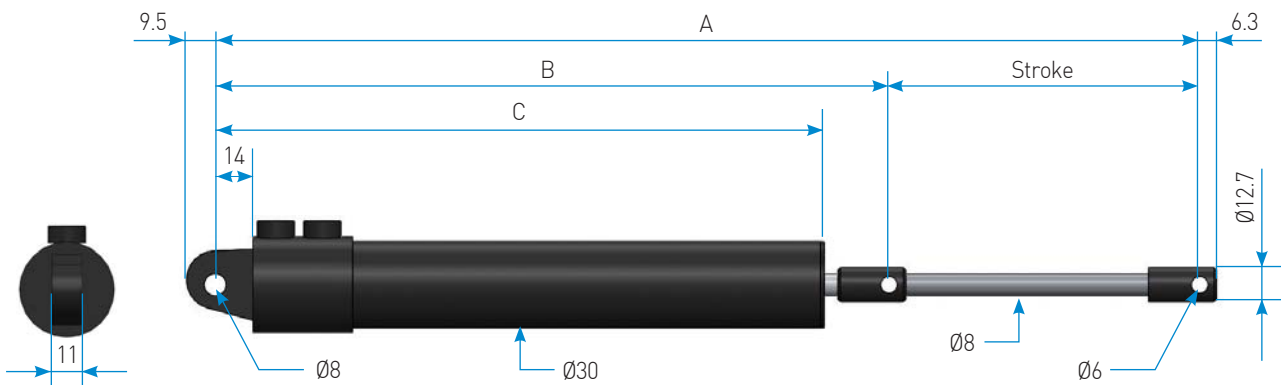

■ Graph

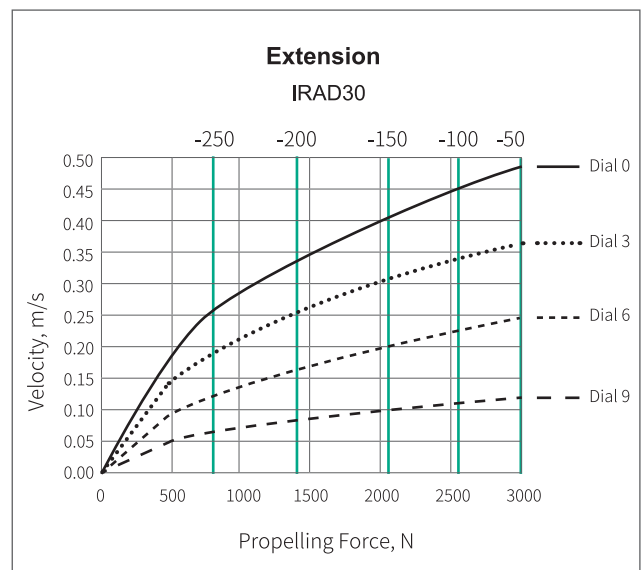
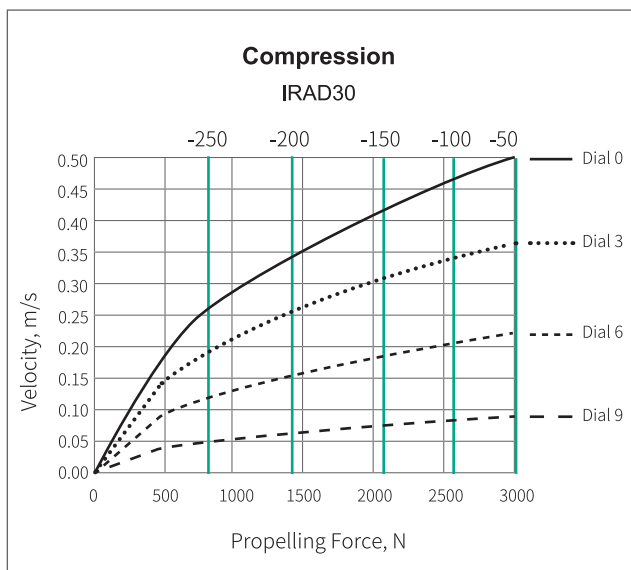

IASR Series Shock Absorber : Short Type

NEW

Izmac Absorber Self short Range absorption

DESCRIPTION

IASR can be installed in a limited space and is suitable for industrial applications requiring high energy absorption. And it is a suitable compact industrial hydraulic product. Unlike general absorber series, it is designed with a unique structure and by way of fast braking time, shock, and noise reduction function, it provides optimum results of best productivity improvement.

FEATURES

- 1 There are various models of different sizes from M16 to M32.
- 2 Specially, it has more than three times maximum energy performance compared to other existing products.
- 3 Improve noise reduction function and increase product durability
- 4 Thanks to the unique orifice structure, it enables smooth absorption characteristics to stop collision material softly.
- 5 Maximum impact speed : 0.05 ~ 3m/s
- 6 Piston rod : Hard Chrome : 25µm
- 7 Available to use without an external stopper.



APPLICATION

Automotive , Mechanical engineering, Electronics industries

IASR SERIES ORDERING INFORMATION

IASR - 16 - 04 - LN

SC : Stop Collar
LN : Lock Nut

Stroke

Body Thread Size

IA : Izmac Absorber
S : Self compensating
R : short Range absorption

Engineering Data

Model	Stroke (mm)	Max.Energy / Cycle(Nm)	Max.Energy / Hour (Nm / h)	Recoil Forec(N)		Weight (g)
				Ext.	Comp.	
IASR16 - 04	4	12	18,000	8	16	1.25
- 09	9	28	42,300	8	17	1.4
IASR20 - 07	7	40	64,600	11	18	65
- 12	12	70	110,700	12	18	75
IASR25 - 08	8	70	108,900	15	20	105
- 15	15	130	204,000	16	21	115

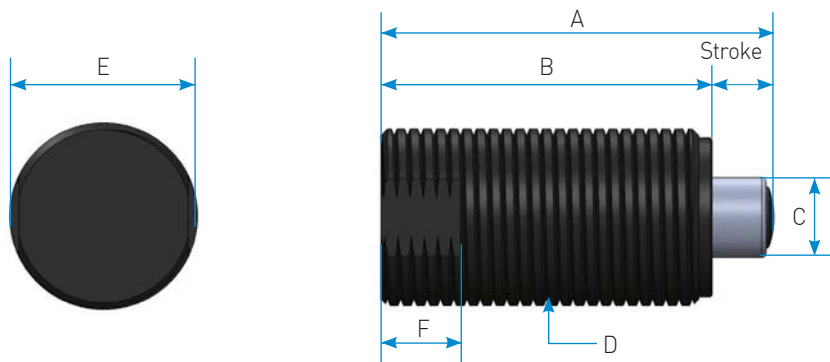

Dimensions

(unit : mm)

Model	Stroke	A	B	C	D	E	F
IASR16 - 04	4	31	27	6	M16 X 1.5P	14	7
- 09	9	49	41	6	M16 X 1.5P	14	7
IASR20 - 07	7	44.5	37.5	9	M20 X 1.5P	18	9
- 12	12	63.5	51.5	9	M20 X 1.5P	18	9
IASR25 - 08	8	52	44	12	M25 X 1.5P	23	10
- 15	15	78	63	12	M25 X 1.5P	23	10

Accessories

(unit : mm)

Model	G	H	I
IASR16 - 04	19	6	12
IASR20 - 07	24	6	16
IASR25 - 08	32	8	18

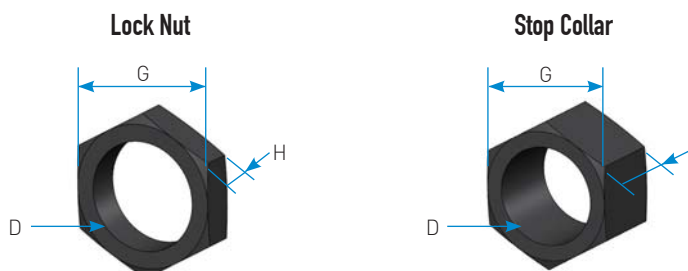

IASR30 ~ 32 Series

Best Engineered
For Energy Absorption!
Technology

Engineering Data

Model	Stroke (mm)	Max.Energy / Cycle(Nm)	Max.Energy / Hour (Nm / h)	Recoil Forec(N)		Weight (g)
				Ext.	Comp.	
IASR30 - 09	9	120	186,000	17	30	200
- 15	15	200	311,000	17	31	210
IASR32 - 13	13	210	323,000	17	30	270
- 20	20	330	498,000	17	31	280

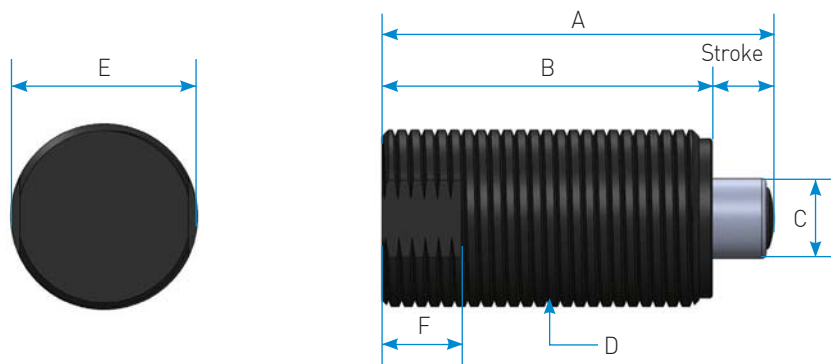

Dimensions

(unit : mm)

Model	Stroke	A	B	C	D	E	F
IASR30 - 09	9	61.5	52.5	16	M30 X 1.5P	28	12
- 15	15	88.5	73.5	16	M30 X 1.5P	28	12
IASR32 - 13	13	76	63	18	M32 X 1.5P	30	13
- 20	20	105	85	18	M32 X 1.5P	30	13

Accessories

(unit : mm)

Model	G	H	I
IASR30 - 09	36	8	20
- 13	44	8	25

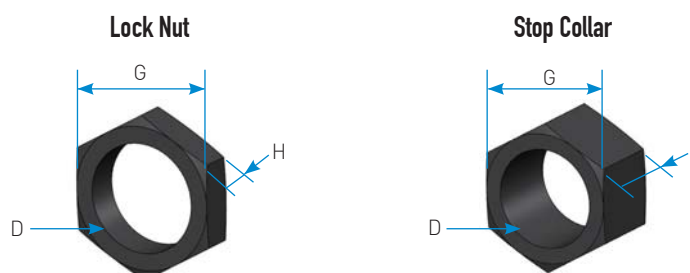



CESEHSA
soluciones

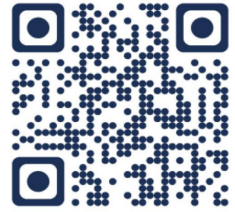

cesehsa.com.mx
info@cesehsa.com.mx

MEMO

Lined area for writing the memo content.