

# REP3 SERIES

## 3-Jaw Parallel Grippers | Features and Benefits | How To Order

### Features:

- Multipurpose robust gripper with high repeatability
- Spring assist option maintains grip in case of air pressure loss
- Uses inductive or magneto resistive sensors for sensing jaw position
- Grip force range from 771N to 2235N
- Purge and scavenge ports for harsh & clean environments
- Repeatability of +/-0.02mm

### Applications:

- Long cycle life requirements
- High vibration environments
- Pick and place, part feeds



## How To Order

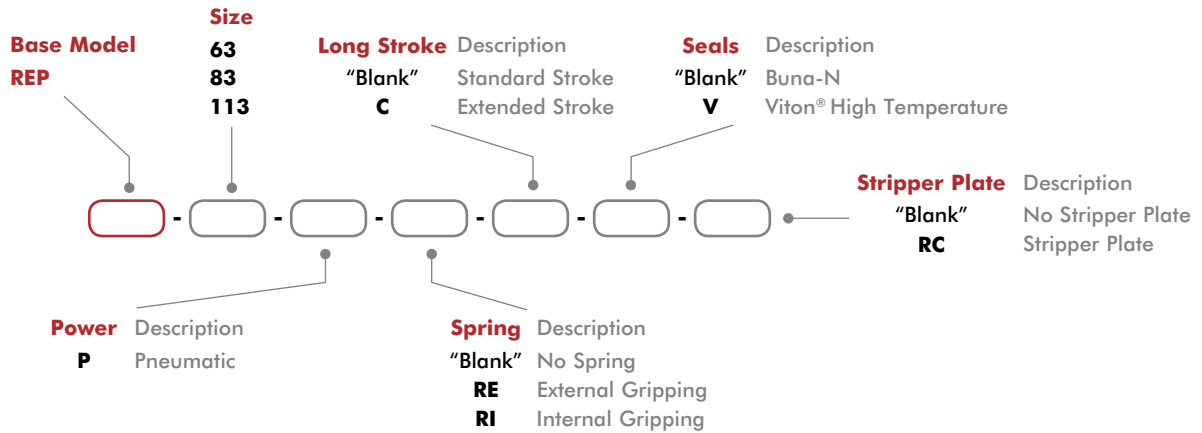

## Accessories

Sensor Accessories	Model Numbers	Part Number	Qty/Unit
NPN Inductive Sensor with M8 Quick Disconnect*	All Models	OISN-011	1-4
PNP Inductive Sensor with M8 Quick Disconnect*	All Models	OISP-011	1-4
NPN Magneto Resistive Sensor with Quick Disconnect*	All Models	OHSN-006	1-2
PNP Magneto Resistive Sensor with Quick Disconnect*	All Models	OHSP-006	1-2
NPN Magneto Resistive Sensor (Short Barrel) with Qk Disconnect*	All Models	OHSN-008	1-2
PNP Magneto Resistive Sensor (Short Barrel) with Qk Disconnect*	All Models	OHSP-008	1-2
M8 Quick Disconnect 2 Meter Cable Length*	All Models	CABL-010	1-4
M8 Quick Disconnect 2 Meter Cable Length*	All Models	CABL-013	1-4
Inductive Sensor Mounting Kit (1 holder, 1 flag, 2 spacers)	63	OSMK-105	1-2
Inductive Sensor Mounting Kit (1 holder, 1 flag, 2 spacers)	83	OSMK-106	1-2
Inductive Sensor Mounting Kit (1 holder, 1 flag, 2 spacers)	113	OSMK-107	1-2

\*Sensor and cable sold separately.

## 3-Jaw Parallel Grippers | Technical Specifications

Specifications	Units	63	63-C	83	83-C	113	113-C
Total Rated Grip Force <b>F</b> @ 100 psi [7 bar]*	N [lbs]	753 [169]	469 [105]	2077 [467]	1341 [301]	3268 [735]	2180 [490]
Total Stroke	mm [in]	10 [0.394]	16 [0.630]	13 [0.512]	20 [0.787]	20 [0.787]	30 [1.181]
Weight	kg [lbs]	0.55 [1.2]		0.9 [2.0]		2.45 [5.4]	
Pressure Range w/o Spring	bar [psi]	2-7 [30-100]					
Pressure Range with Spring	bar [psi]	3-7 [45-100]					
Ingress Protection Class (IP)		IP55					
Displacement	cm <sup>3</sup> [in <sup>3</sup> ]	12 [0.72]		35 [2.13]		87 [5.31]	
Temperature Range (Buna-N seals)	°C [°F]	-35°~80° [-30°~180°]					
Temperature Range (Viton® seals)	°C [°F]	-30°~150° [-20°~300°]					
Actuation (open/close)	sec.	0.10		0.18		0.35	
Accuracy	mm [in]	±0.05 [±0.002]					
Repeatability	mm [in]	±0.02 [±0.0008]					
Valve to Actuate Single Acting		3-way, 2-position					
Valve to Actuate Double Acting		4-way, 2-position					

\* with springs

# REP-63, -63-C

## 3-Jaw Parallel Grippers | Dimensions and Technical Specifications

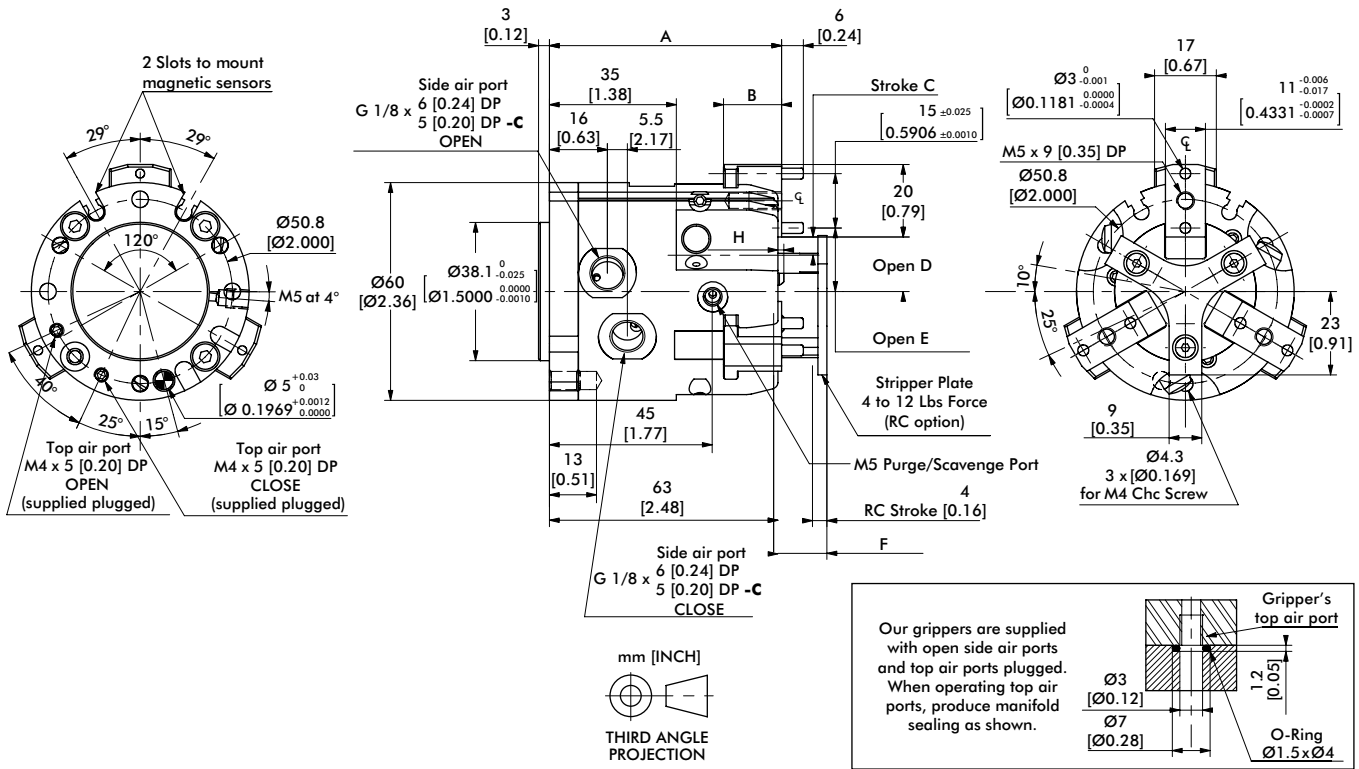

Model	A	B	C	D	E	F	H
REP-63	62 [2.52]	16 [0.63]	5 [0.20]	15 [0.59]	17.5 [0.689]	13.5 [0.531]	1.6 [0.06]
REP-63-C	68 [2.68]	20 [0.79]	8 [0.31]	21 [0.83]	23.5 [0.926]	17.5 [0.689]	5.6 [0.22]

Dimensions in mm [in]

Seal Repair Kits	REP-63
Buna-N Seal Repair Kit	SLKT-155
Viton® Seal Repair Kit	SLKT-155V

### Loading Information

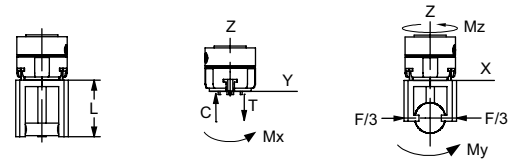
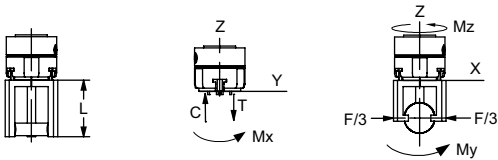
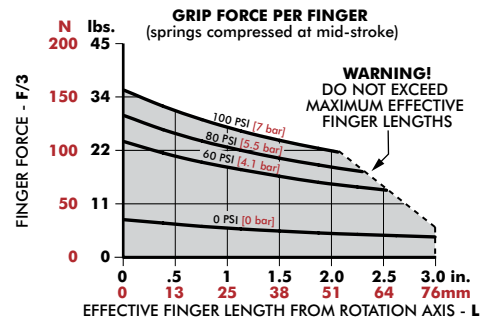
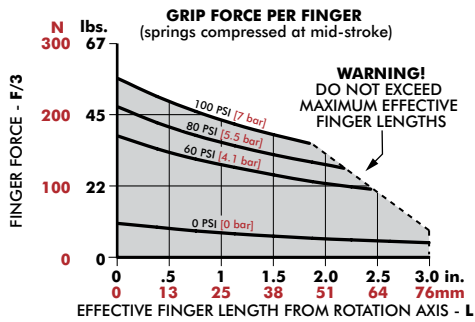

REP-63	Static
Maximum Tensile <b>T</b>	860 N [193 lbs]
Maximum Compressive <b>C</b>	1150 N [259 lbs]
Maximum Moment <b>M<sub>x</sub></b>	18 Nm [159 in-lbs]
Maximum Moment <b>M<sub>y</sub></b>	30 Nm [266 in-lbs]
Maximum Moment <b>M<sub>z</sub></b>	30 Nm [44 in-lbs]

REP-63-C	Static
Maximum Tensile <b>T</b>	860 N [193 lbs]
Maximum Compressive <b>C</b>	1150 N [259 lbs]
Maximum Moment <b>M<sub>x</sub></b>	15 Nm [133 in-lbs]
Maximum Moment <b>M<sub>y</sub></b>	30 Nm [266 in-lbs]
Maximum Moment <b>M<sub>z</sub></b>	50 Nm [443 in-lbs]

†Capacities are per set of jaws and are not simultaneous

†Capacities are per set of jaws and are not simultaneous

## 3-Jaw Parallel Grippers | Dimensions and Technical Specifications

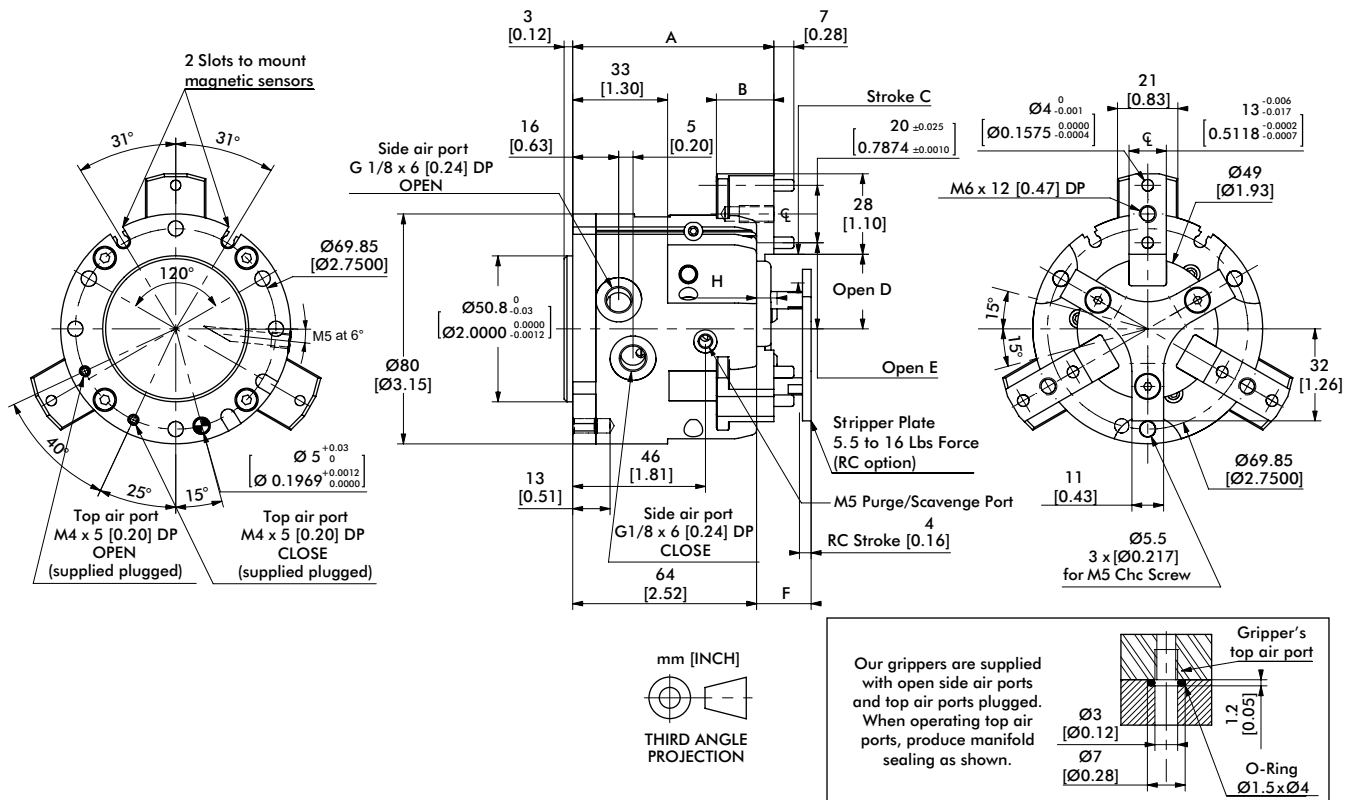

Model	A	B	C	D	E	F	H
REP-83	65 [2.56]	15 [0.59]	6.5 [0.256]	19 [0.75]	23 [0.91]	14 [0.55]	2.1 [0.08]
REP-83-C	70 [2.76]	20 [0.79]	10 [0.39]	26 [1.10]	30 [1.18]	19 [0.75]	7.1 [0.28]

Dimensions in mm [in]

Seal Repair Kits	REP-83
Buna-N Seal Repair Kit	SLKT-157
Viton® Seal Repair Kit	SLKT-157V

## Loading Information

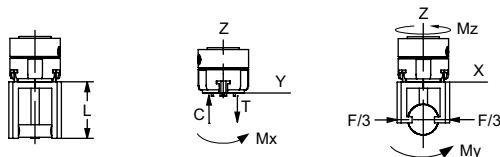
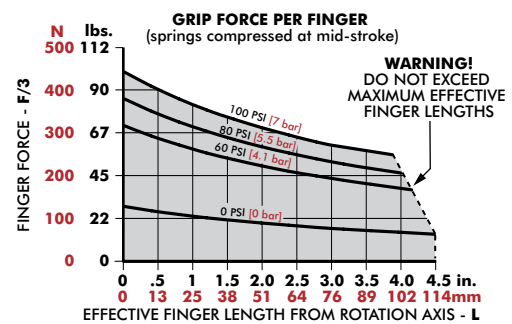
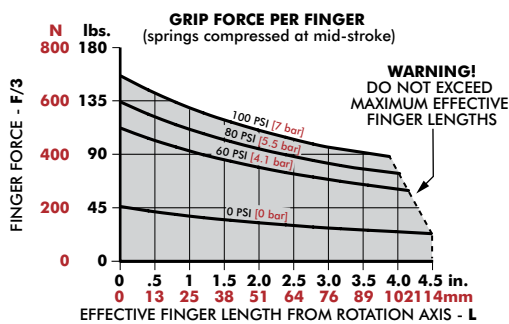

REP-83	Static
Maximum Tensile <b>T</b>	1250 N [281 lbs]
Maximum Compressive <b>C</b>	1400 N [315 lbs]
Maximum Moment <b>M<sub>x</sub></b>	30 Nm [266 in-lbs]
Maximum Moment <b>M<sub>y</sub></b>	55 Nm [487 in-lbs]
Maximum Moment <b>M<sub>z</sub></b>	60 Nm [531 in-lbs]

†Capacities are per set of jaws and are not simultaneous

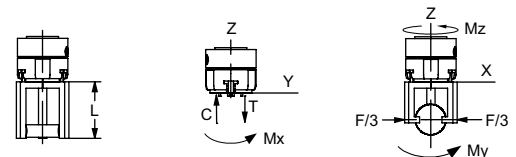

REP-83-C	Static
Maximum Tensile <b>T</b>	1210 N [272 lbs]
Maximum Compressive <b>C</b>	1360 N [306 lbs]
Maximum Moment <b>M<sub>x</sub></b>	25 Nm [221 in-lbs]
Maximum Moment <b>M<sub>y</sub></b>	50 Nm [443 in-lbs]
Maximum Moment <b>M<sub>z</sub></b>	60 Nm [531 in-lbs]

†Capacities are per set of jaws and are not simultaneous

# REP-113, -113-C

## 3-Jaw Parallel Grippers | Dimensions and Technical Specifications

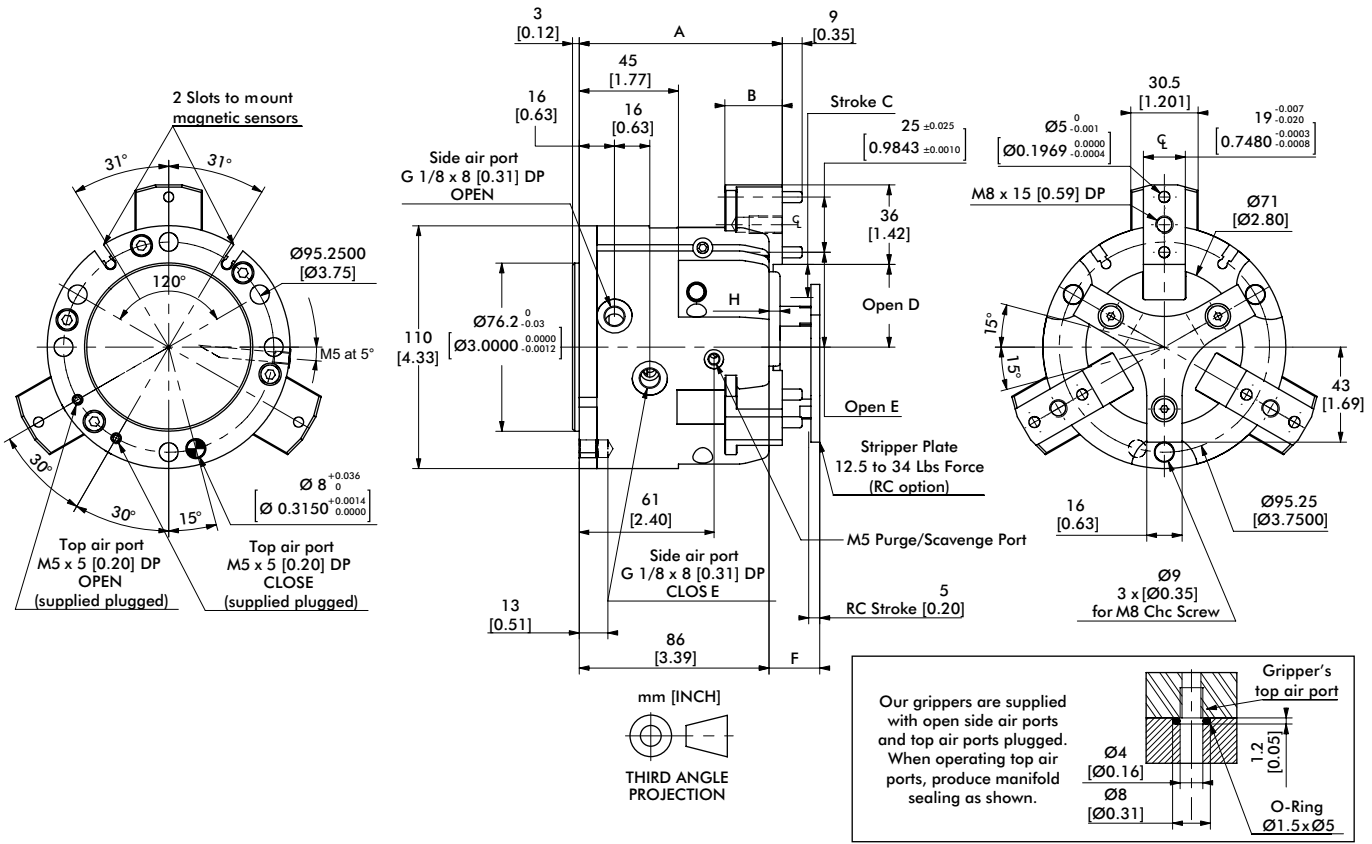

Model	A	B	C	D	E	F	H
REP-113	87 [3.43]	21 [0.83]	10 [0.39]	27.5 [1.083]	33 [1.30]	18 [0.71]	--
REP-113-C	92 [3.62]	26 [1.02]	15 [0.59]	37.5 [1.476]	43 [1.69]	23 [0.91]	5 [0.20]

Dimensions in mm [in]

Seal Repair Kits	REP-113
Buna-N Seal Repair Kit	SLKT-158
Viton® Seal Repair Kit	SLKT-158V

## Loading Information

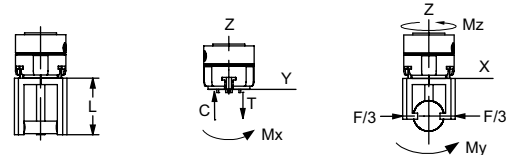
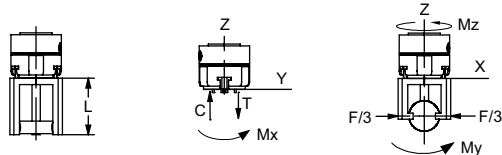
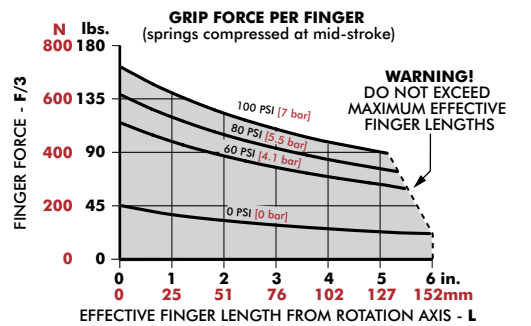
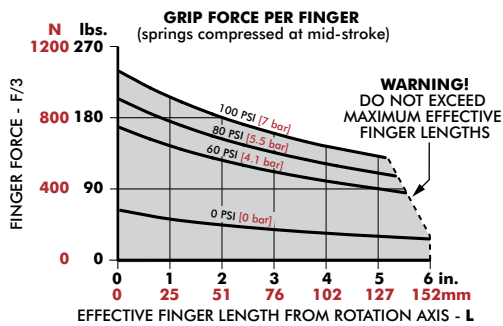

REP-113	Static
Maximum Tensile <b>T</b>	1980 N [445 lbs]
Maximum Compressive <b>C</b>	2150 N [483 lbs]
Maximum Moment <b>M<sub>x</sub></b>	58 Nm [513 in-lbs]
Maximum Moment <b>M<sub>y</sub></b>	100 Nm [885 in-lbs]
Maximum Moment <b>M<sub>z</sub></b>	110 Nm [974 in-lbs]

<sup>†</sup>Capacities are per set of jaws and are not simultaneous

REP-113-C	Static
Maximum Tensile <b>T</b>	1970 N [443 lbs]
Maximum Compressive <b>C</b>	2140 N [481 lbs]
Maximum Moment <b>M<sub>x</sub></b>	52 Nm [460 in-lbs]
Maximum Moment <b>M<sub>y</sub></b>	100 Nm [885 in-lbs]
Maximum Moment <b>M<sub>z</sub></b>	110 Nm [974 in-lbs]

<sup>†</sup>Capacities are per set of jaws and are not simultaneous