

VDC Series

High-Pressure Type Variable Volume Vane Pump

30 to 120ℓ/min
14MPa

Features

① Highly efficient and stable high-pressure operation

Innovative pressure control and pressure balance mechanisms combine with an original 3-point ring support system dramatically improves high-pressure operation. The result is outstanding performance at high pressures up to 14MPa.

② Low vibration and noise

A number of innovative new mechanisms are adopted to minimize vibration and noise. In particular, a 3-point support system is used for the control piston and bias piston to increase ring

stability. This minimizes ring vibration and delivers quiet operation.

③ Outstanding response, high-precision operation

An innovative new ring stopper eliminates excessive ring displacement and improves response. The result is high precision operation at all times, including during starts, stops, and load changes.

④ Precise characteristics for a stable discharge rate

A revolutionary new pressure compensator type pressure control mechanism

ensures a highly stable fixed discharge rate, even in the high pressure range.

⑤ High efficiency operation with minimal power loss

New mechanical innovations minimize power loss, especially at full cutoff.

⑥ Simplified maintenance and handling

Pressure adjusting and discharge rate adjusting mechanisms are located on the same side of the pump for simplified maintenance and handling.

Specifications

Model No.	Capacity cm ³ /rev	No-load Discharge Rate ℓ/min				Pressure Adjustment Range MPa {kgf/cm ² }	Allowable Peak Pressure MPa {kgf/cm ² }	Revolution Speed min ⁻¹		Weight kg
		1000min ⁻¹	1200min ⁻¹	1500min ⁻¹	1800min ⁻¹			Min.	Max.	
VDC-1A(B)-1A2-20 1A3 1A4 1A5	16.7	16.7	20	25	30	1.5 to 3.5 {15.3 to 35.7} 2 to 7 {20.4 to 71.4} 5 to 10.5 {51 to 107} 7 to 14 {71.4 to 143}	14 {143} 21 {214}	800	1800	9.5
VDC-1A(B)-2A2-20 2A3	22	22	27	33	40	1.5 to 3.5 {15.3 to 35.7} 2 to 7 {20.4 to 71.4}	14 {143}	800	1800	9.5
VDC-2A(B)-1A2-20 1A3 1A4 1A5	30	30	36	45	54	1.5 to 3.5 {15.3 to 35.7} 2 to 7 {20.4 to 71.4} 5 to 10.5 {51 to 107} 7 to 14 {71.4 to 143}	14 {143} 21 {214}	800	1800	25
VDC-2A(B)-2A2-20 2A3	39	39	47	58	70	1.5 to 3.5 {15.3 to 35.7} 2 to 7 {20.4 to 71.4}	14 {143}	800	1800	25
VDC-3A(B)-1A2-20 1A3 1A4 1A5	67	67	80	100	120	1.5 to 3.5 {15.3 to 35.7} 2 to 7 {20.4 to 71.4} 5 to 10.5 {51 to 107} 7 to 14 {71.4 to 143}	14 {143} 21 {214}	800	1800	47 (33)

Double Pump

Model No.	Vent Side			Shaft Side			Revolution Speed min ⁻¹		Weight kg
	Discharge Rate ℓ/min		Pressure Adjust- ment Range MPa {kgf/cm ² }	Discharge Rate ℓ/min		Pressure Adjust- ment Range MPa {kgf/cm ² }	Min.	Max.	
	1800min ⁻¹	1500min ⁻¹		1800min ⁻¹	1500min ⁻¹				
VDC-11A(B)-2A3-2A3-20 VDC-11A(B)-2A3-1A5-20	40	33	2 to 7 {20.4 to 71.4}	40 30	33 25	2 to 7 {20.4 to 71.4} 7 to 14 {71.4 to 143}	800	1800	Type A 27 Type B 20
VDC-12A(B)-2A3-2A3-20 VDC-12A(B)-2A3-1A5-20 VDC-12A(B)-1A5-2A3-20 VDC-12A(B)-1A5-1A5-20	40 30	33 25	2 to 7 {20.4 to 71.4} 7 to 14 {71.4 to 143}	70 54 70 54	58 45 58 45	2 to 7 {20.4 to 71.4} 7 to 14 {71.4 to 143} 2 to 7 {20.4 to 71.4} 7 to 14 {71.4 to 143}	800	1800	Type A 42 Type B 35
VDC-22A(B)-2A3-2A3-20 VDC-22A(B)-2A3-1A5-20	70	58	2 to 7 {20.4 to 71.4}	70 54	58 45	2 to 7 {20.4 to 71.4} 7 to 14 {71.4 to 143}	800	1800	Type A 62 Type B 50
VDC-13A(B)-2A3-1A3-20 VDC-13A(B)-2A3-1A5-20 VDC-13A(B)-1A5-1A3-20 VDC-13A(B)-1A5-1A5-20	40 30	33 25	2 to 7 {20.4 to 71.4} 7 to 14 {71.4 to 143}	120	100	2 to 7 {20.4 to 71.4} 7 to 14 {71.4 to 143} 2 to 7 {20.4 to 71.4} 7 to 14 {71.4 to 143}	800	1800	Type A 62 Type B 48

Note) 1. VDC-3A, VDC-11A, VDC-12A and VDC-13A are foot mounting types, and come with foot mountings.
2. VDC-1A and VDC-2A are sub plate types. Sub plates are not included.

● Handling

- 1] Rotation Direction The direction of rotation is always clockwise (rightward) when viewed from the shaft side.
- 2] Drain Drain piping must be direct piping up to a point that is below the tank fluid level, and piping should comply with the conditions shown in the table below to ensure that back pressure due to pipe resistance does not exceed 0.1MPa. When using a pump that has drain ports at two locations, use the drain port that is higher after the pump is installed. In the case of a double pump, run separate pipes from both the shaft side and the head side drains directly connect to the tank, so the drain pipe is below the surface of the oil.

Model No.	VDC-1	VDC-2	VDC-3
Pipe Joint Size	At least 1/4"	At least 1/4"	At least 3/8"
Pipe I.D.	At least ϕ 7.6	At least ϕ 7.6	At least ϕ 9.6
Pipe Length	1m or less	1m or less	1m or less

- 3] Discharge Volume Adjustment
The discharge flow rate is decreased by clockwise (rightward) rotation of the discharge rate adjusting screw, and increased by counterclockwise (leftward) rotation. Loosen the lock nut before making adjustments. After adjustment is complete, re-tighten the lock nut. The graph below provides general guidelines for the relationship between the rotation angle of the flow rate adjusting screw and the no-load discharge rate.
However: $Q=q \times N \times 10^{-3}$
Q : No-load Discharge Rate $Q\ell/\text{min}$
q : Volume cm^3/rev
N : Revolution Speed min^{-1}

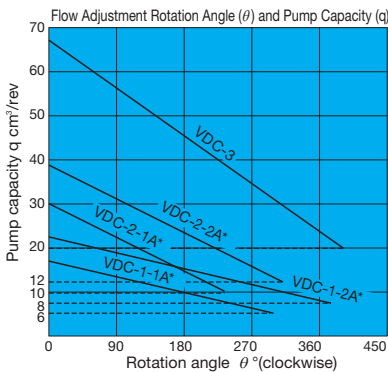

- 5] Factory Default P-Q Settings (Standard Model)
 - Flow Rate Setting = Maximum flow rate for model as indicated in the catalog
 - Pressure Setting = Pressure shown in table below
- 6] Thrust Screw and Stopper
The thrust screw and stopper are precision adjusted at the factory during assembly. Never touch them. See callouts 15/43 and 15/38 in the VDC-1A and 2A/3A cross-section diagrams on pages B-33 and B-34.
- 7] An unload circuit is required when the motor is started under condition $\lambda - \Delta$. Contact your agent about the unload circuit.
- 8] Initial Operation
Before operating the pump for the first time, put the pump discharge side into the no-load state and then repeatedly start and stop the motor to bleed all air from inside the pump and the suction piping. After confirming that the pump is discharging oil, continue the no-load operation for at least 10 minutes to discharge all the air from the circuit. Provide an air bleed valve in circuits where it is difficult to bleed air before startup.
- 9] Sub Plate
Use the table below for to specify a sub plate type when one is required.
- 10] Foot Mounting
For a double pump with VDC-3 foot mounting, the foot mounting kit and pump are sold as a set. When only the mounting feet are required, pump mounting bolts, washers and other parts are sold together as the Foot Mounting Kit. See page B-36 for detailed dimensions.

Factory Default Pressure Settings MPa(kgf/cm ²)
2 : 3.5 {35.7}
3 : 3 {30.6}
4 : 5 {51 }
5 : 7 {71.4}

- 11] For the hydraulic operating fluid, use type ISO VG32 or equivalent (viscosity index of at least 90) for pressures of 7MPa or lower, and type ISO VG68 or equivalent (viscosity index of at least 90) for pressures greater than 7MP.
- 12] The operating temperature range is 15 to 60°C. When the oil temperature at startup is 15°C or less, perform a warm-up operation at low pressure until the oil temperature reaches 15°C. Use the pump in an area where the temperature is within the range of 0 to 60°C.
- 13] Suction pressure is -0.03 to +0.03MPa (-0.3 to +0.3kgf/cm²), and the suction port flow rate should be no greater than 2m/sec.
- 14] Avoid pulley, gear, and other drive systems that impart a radial or thrust load on the end of the pump shaft. Mount the pump so its pump shaft is oriented horizontally.
- 15] Provide a suction strainer with a filtering grade of about 100 μm (150 mesh). For the return line to the tank, use a 25 μm line filter.
- 16] Manage hydraulic operating fluid so contamination is maintained at class NAS10 or lower. Take care to avoid contamination with water and other foreign matter, and watch out for discoloration. Whitish fluid indicates that air has contaminated the fluid, and brownish fluid indicates the fluid is dirty.
- 17] Contact your agent about using water- and glycol-based hydraulic operating fluids.
- 18] At startup, repeat the inching operation (start-stop) to prime the pump and bleed air from the pump and pipes. (This pump has no fluid supply port.)

(Continued on following page)

Note)

The values indicated above are at maximum pump discharge volume with the flow volume adjusting screw at the 0° position. The broken line shows the flow volume adjustment range lower limit value.

- 4] Pressure Adjustment Pressure is increased by clockwise (rightward) rotation of the discharge rate adjusting screw, and decreased by counterclockwise (leftward) rotation. Loosen the lock nut before making adjustments. After adjustment is complete, re-tighten the lock nut.

Sub Plate Number

Pump Model No.	Sub Plate Number	Motor kW
VDC-1A-1A*-20	MVD-1-115-10	0.75 to 1.5
	MVD-1-135-10	2.2 to 3.7
VDC-1A-2A*-20	MVD-1-115Y-10	0.75 to 1.5
	MVD-1-135Y-10	2.2 to 3.7
VDC-2A-*A*-20	MVD-2-135-10	2.2 to 3.7
	MVD-2-160-10	5.5
VDC-2A-2A*-20	MVD-2-160Z-10	5.5

Note) See pages B-17 and B-18 for detailed dimensions.

19 Equip an air bleed valve in circuits where it is difficult to bleed air before startup. See page C-13 for more information.

20 When centering the pump shaft, eccentricity with the motor shaft should be no greater than 0.05mm. Use a pump mounting base of sufficient rigidity.

The angle error should be no greater than 1°.

● Inverter Drive Precautions

1 Set the revolution speed within the range of the pump specification revolution speed.

2 Changing the revolution speed may also affect the pump performance curves. Before using the inverter, check if the pressure and motor load factor are within the range of use.

Explanation of model No.

Single Pump

VDC - 2 A - 1 A 2 - 20

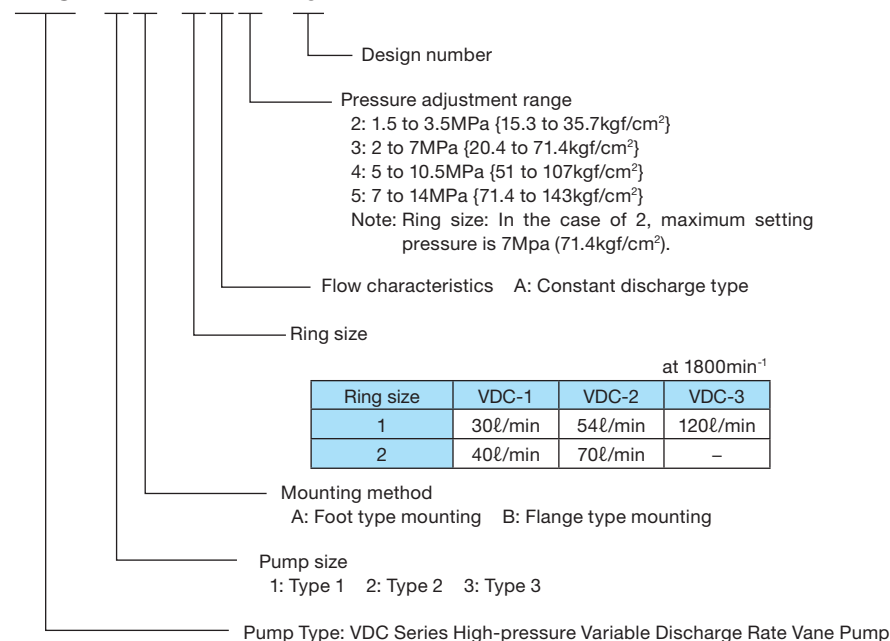

Double Pump

VDC - 1 2 A - 1 A 5 - 2 A 3 - 20

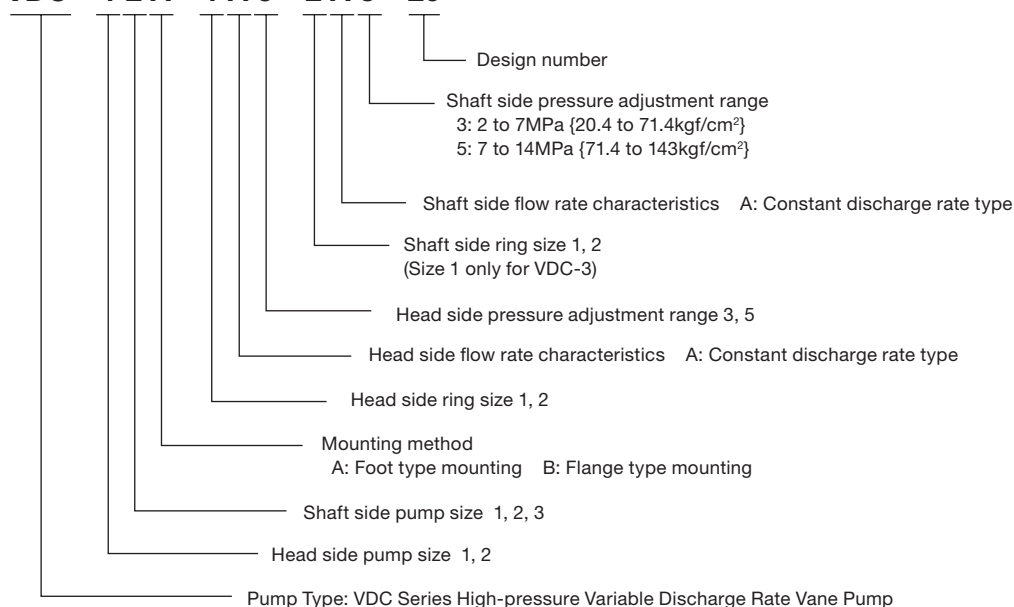

Installation Dimension Drawings

Single Pump
VDC-1A-*A*-20

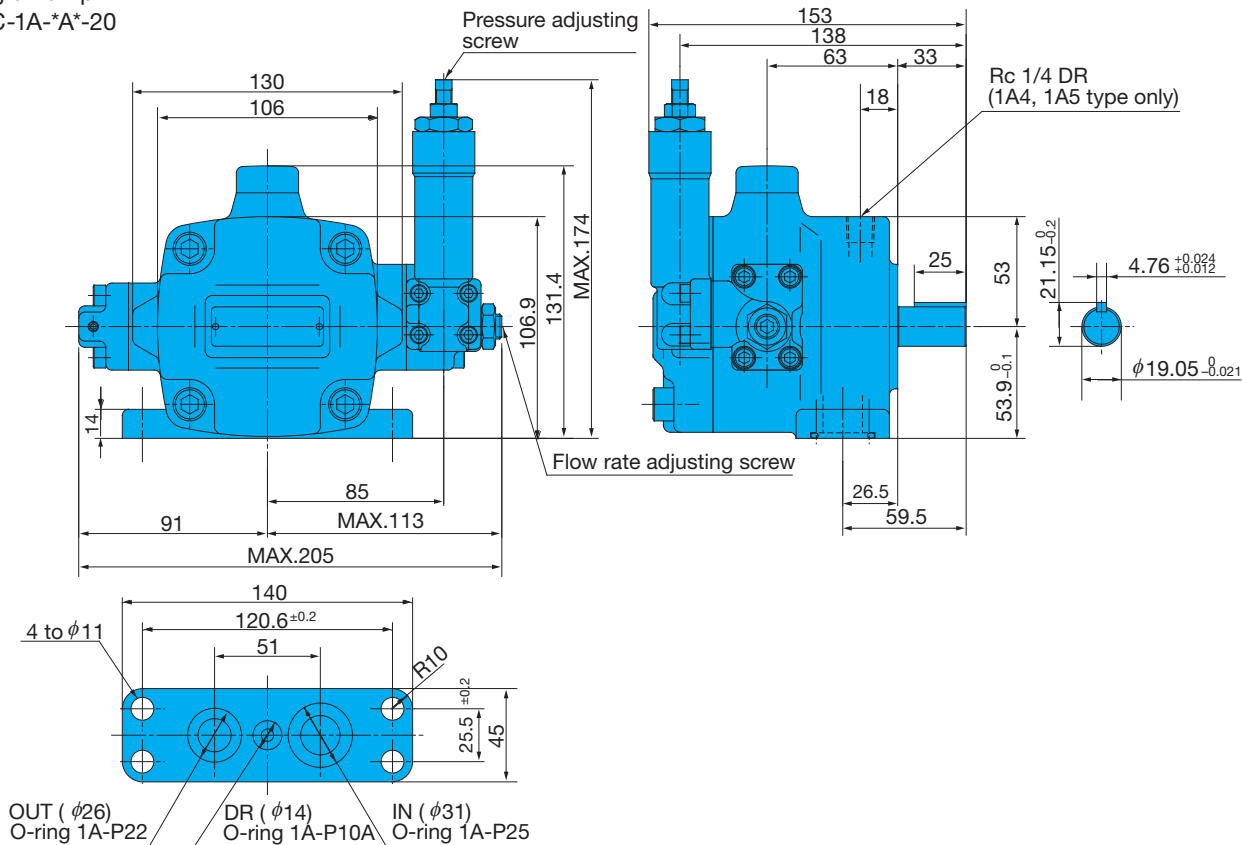

VDC-1B-*A*-20

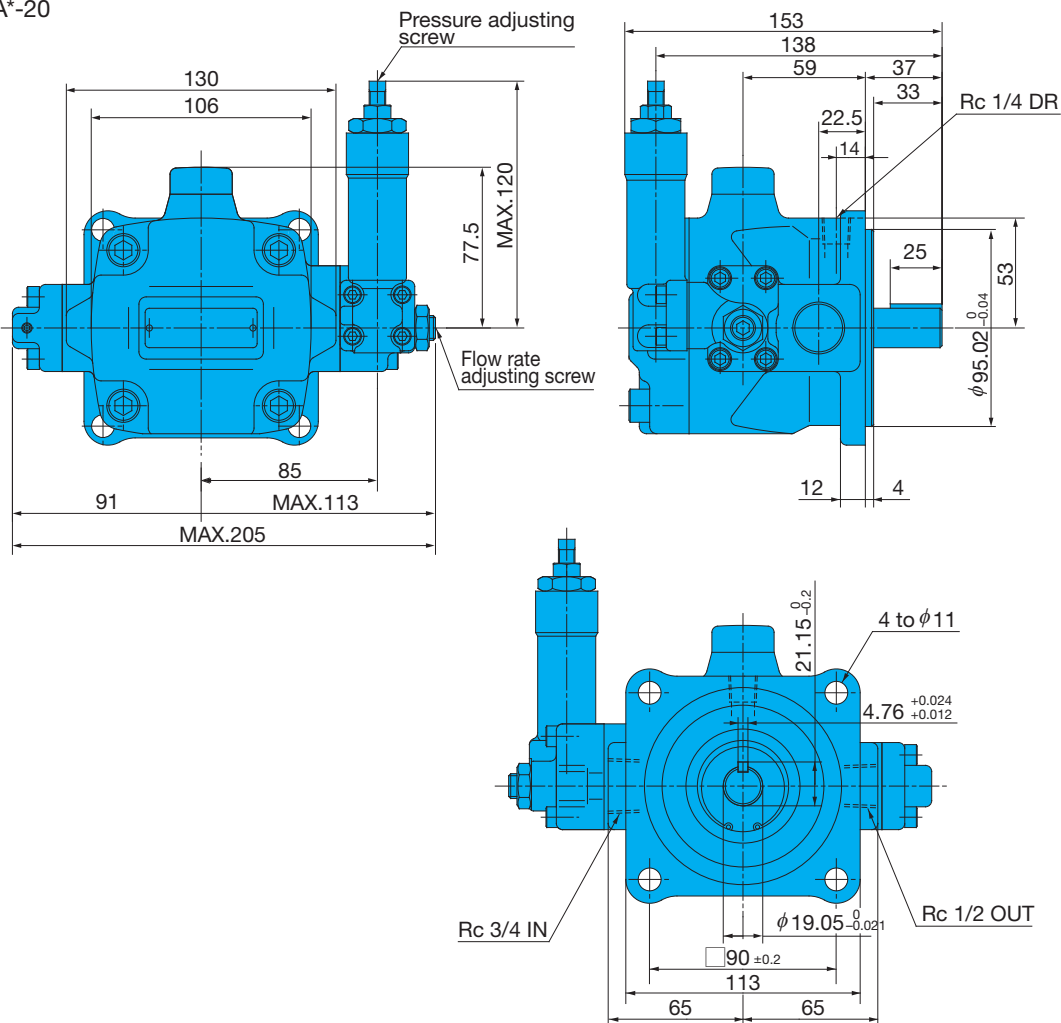

VDC-2A-*A*-20

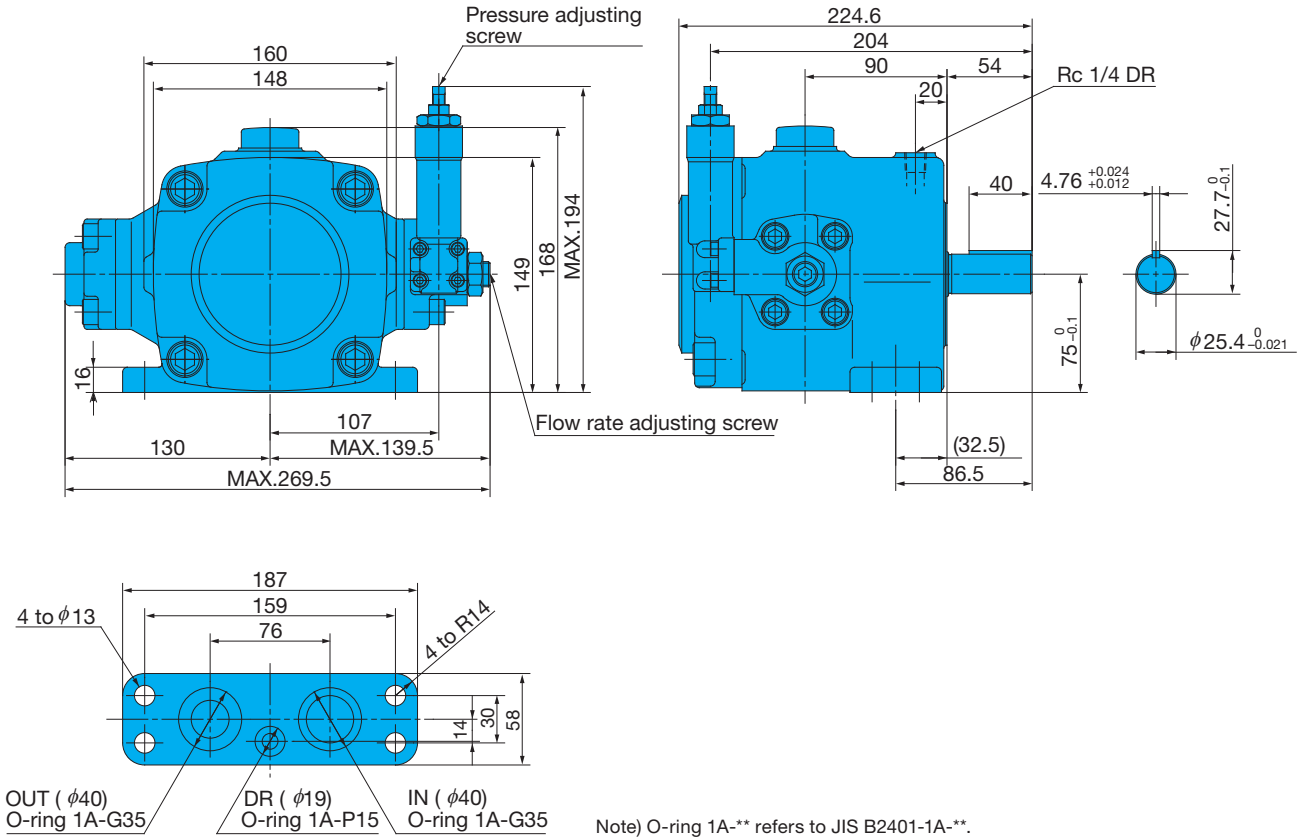

VDC-2B-*A*-20

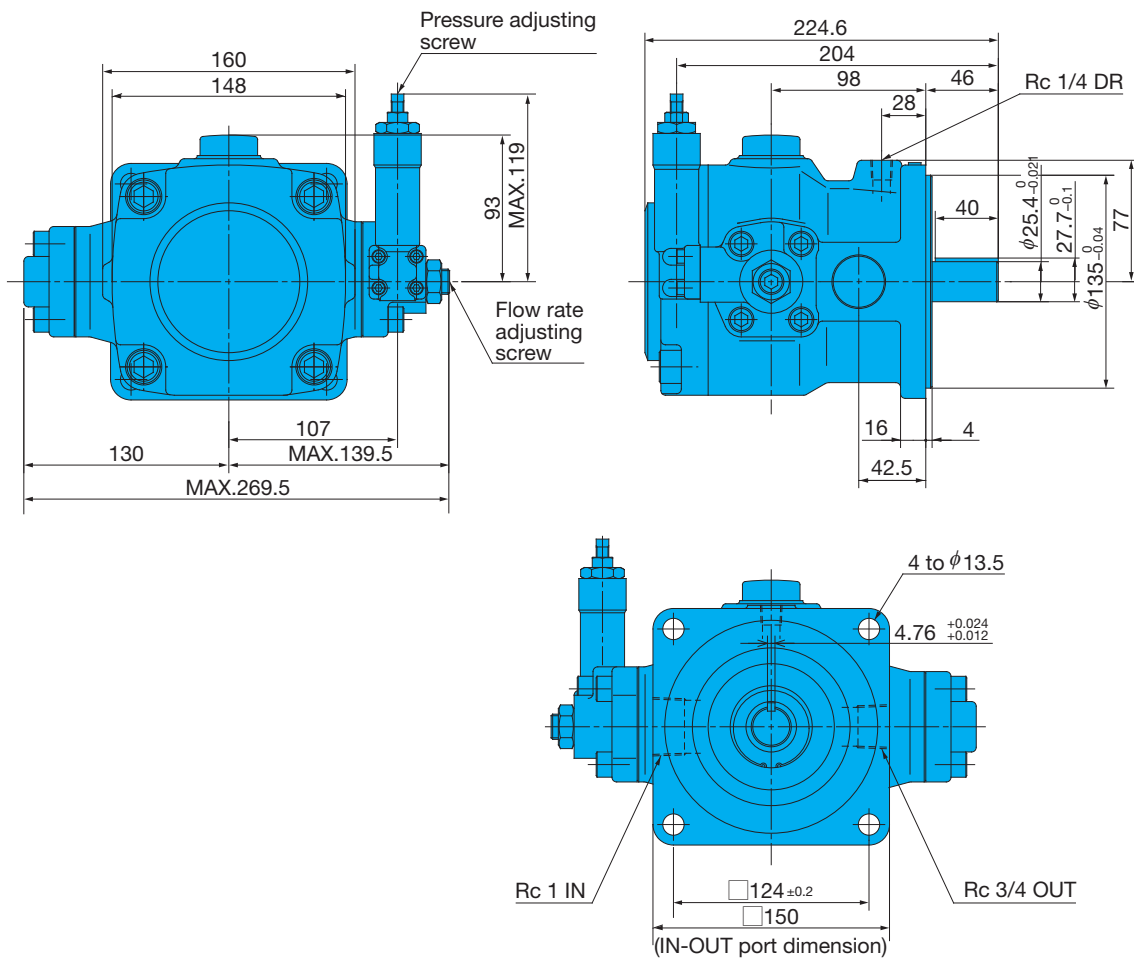

VDC-3A-1A*-20

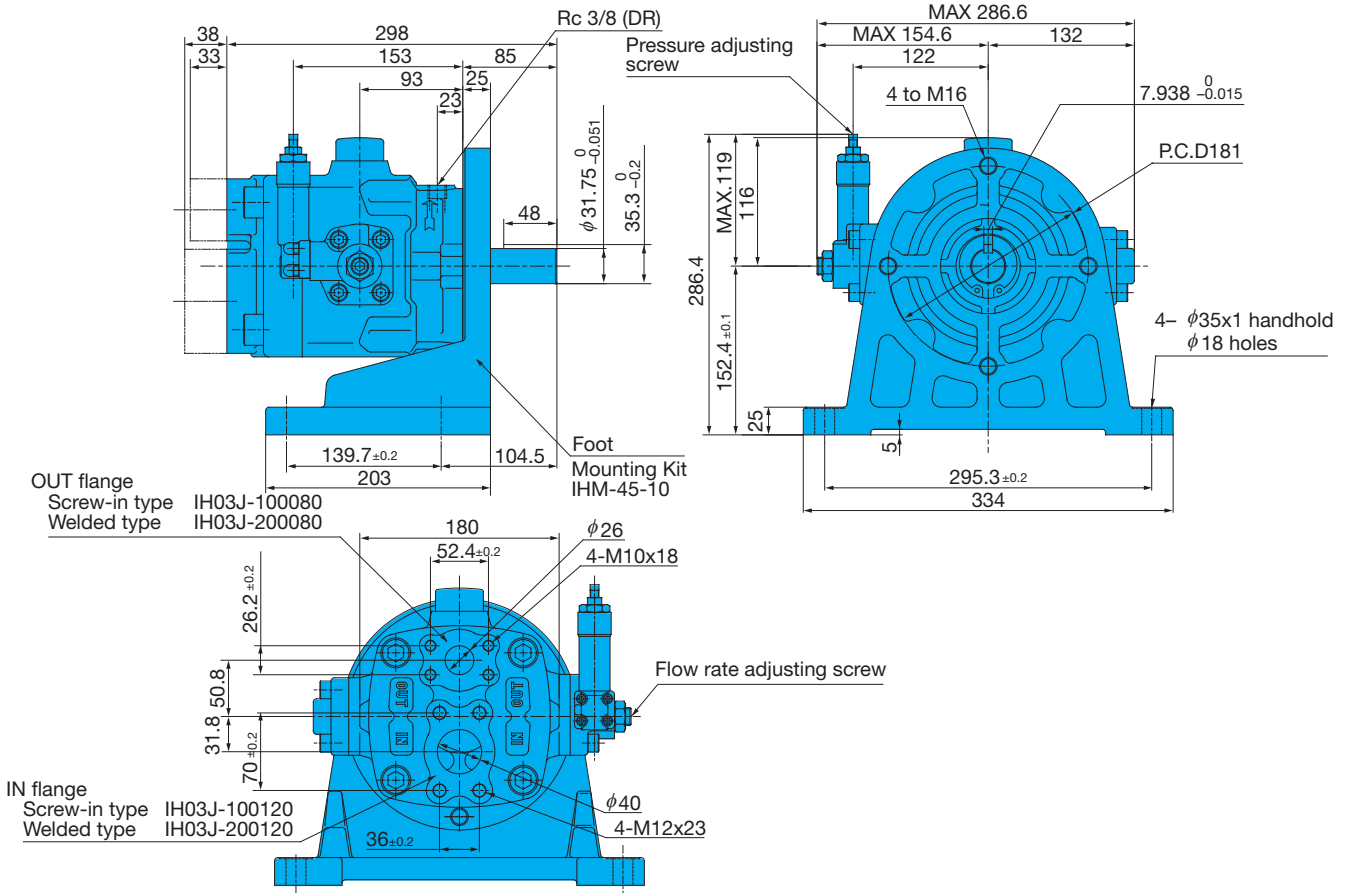

VDC-3B-1A*-20

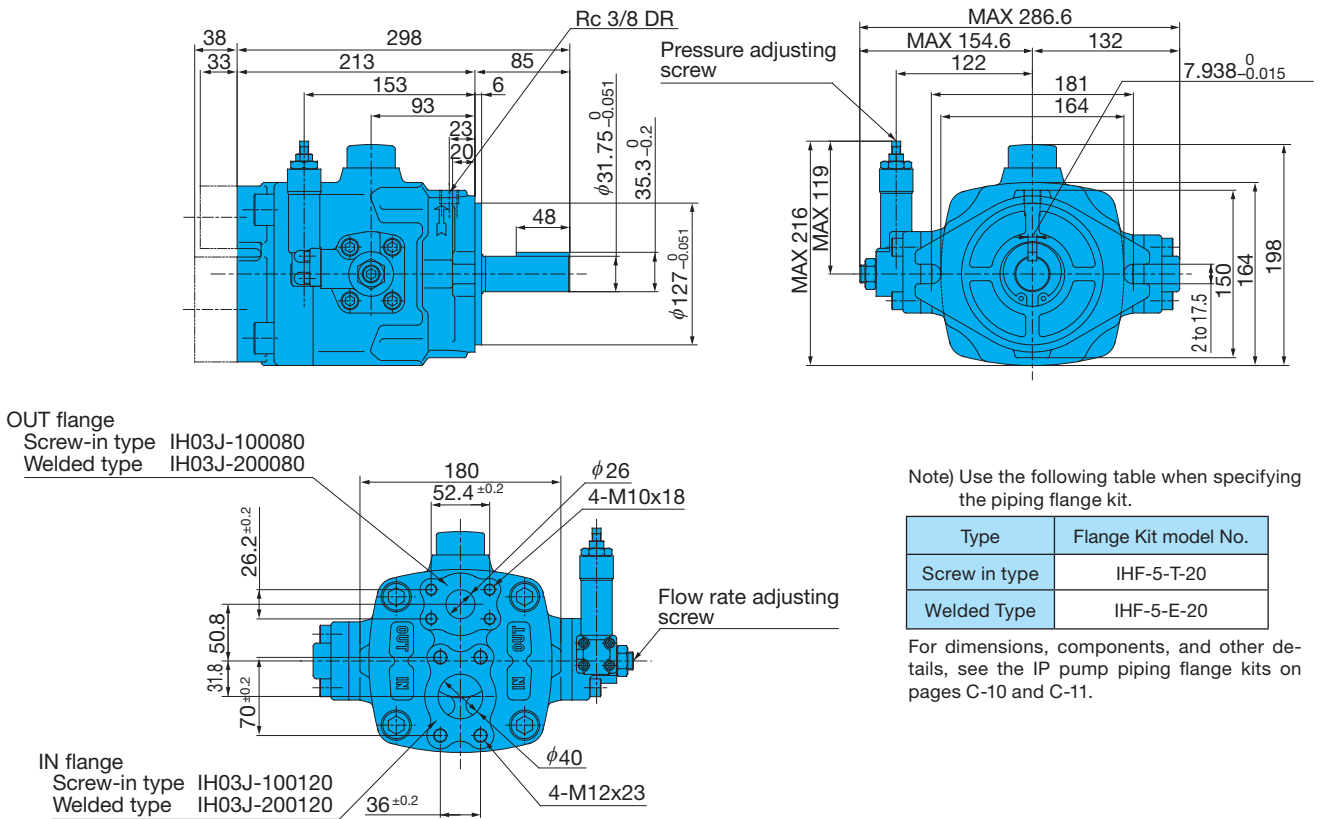

Note) Use the following table when specifying the piping flange kit.

Type	Flange Kit model No.
Screw in type	IHF-5-T-20
Welded Type	IHF-5-E-20

For dimensions, components, and other details, see the IP pump piping flange kits on pages C-10 and C-11.

Double Pump
VDC-11B-*A*-*A*-20

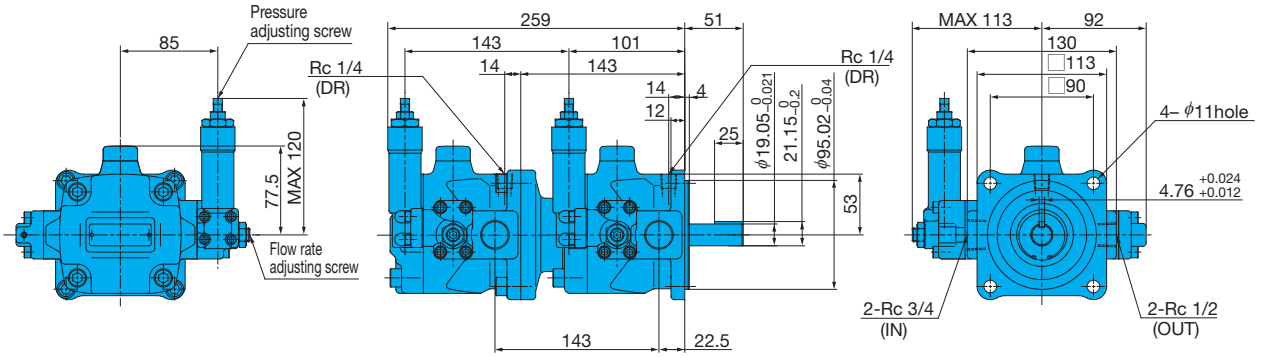

VDC-12B-*A*-*A*-20

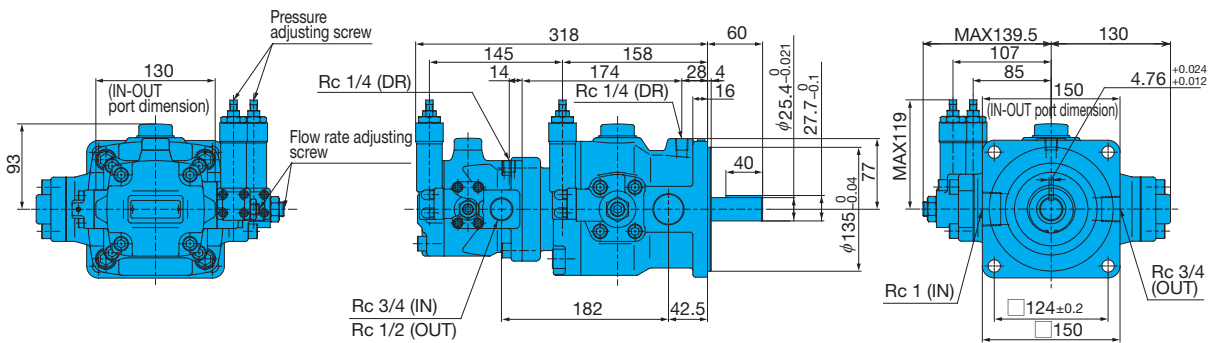

VDC-22B-*A*-*A*-20

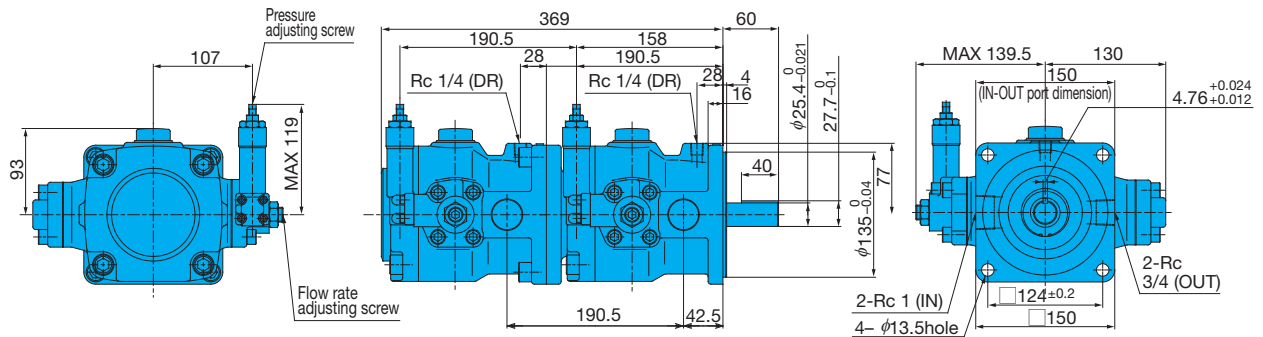

VDC-13B-*A*-*A*-20

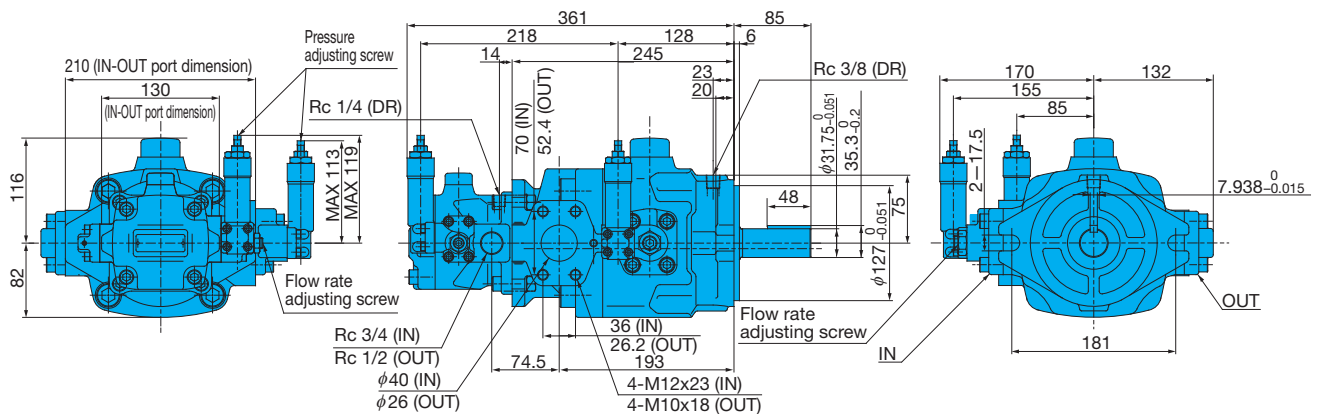

Note) 1. VDC-**A has the foot mounting kit shown on page B-36 installed.
2. Rc-* previously was PT*.

Performance Curves

Typical characteristics at hydraulic operating fluid kinematic viscosity of 32 mm²/s

B
Vane Pumps

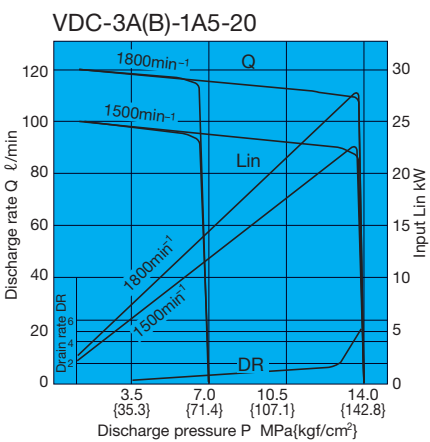
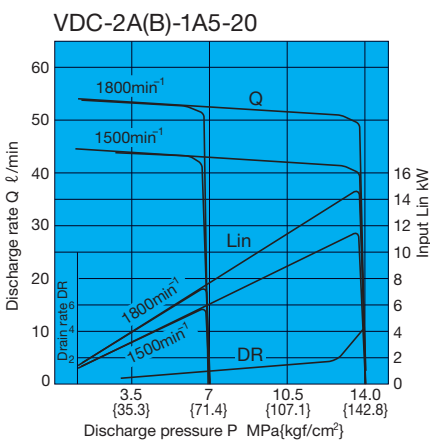
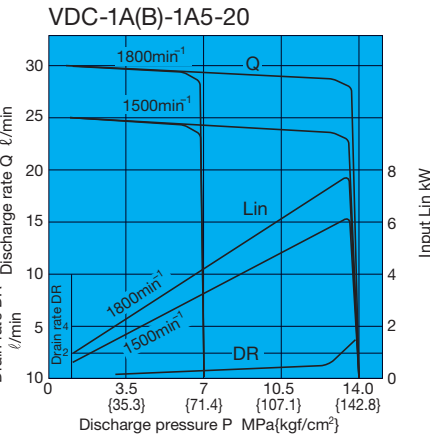
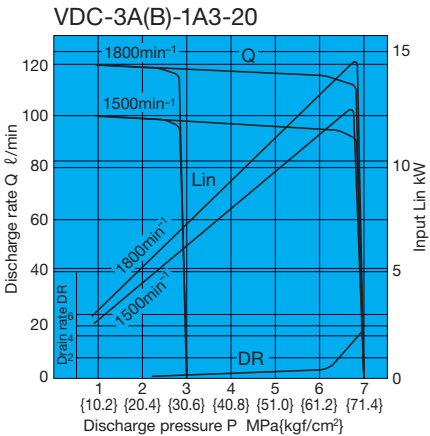
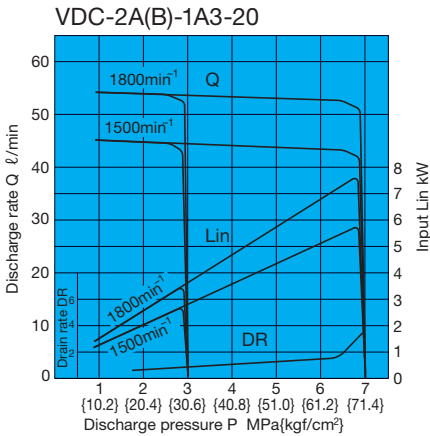
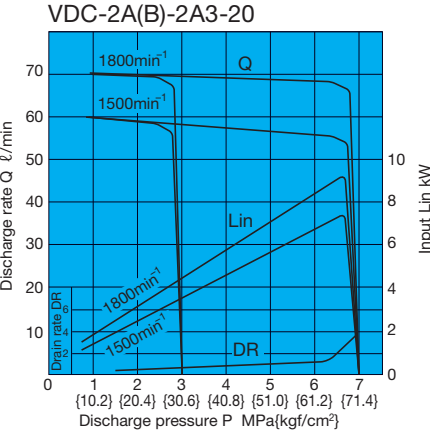
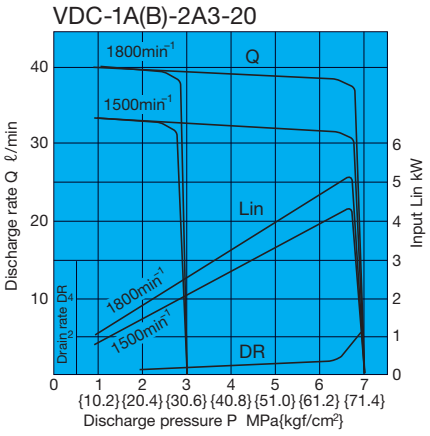
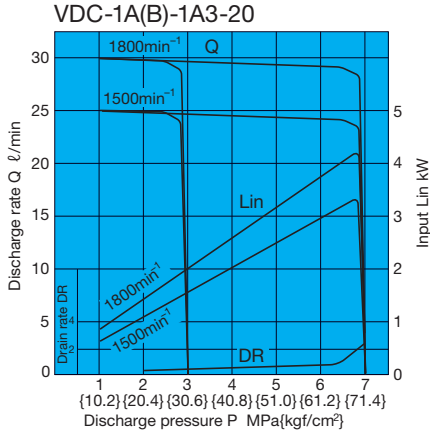

Axial input at full cutoff

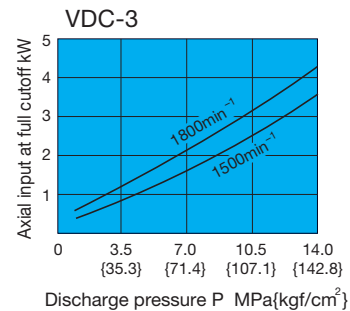
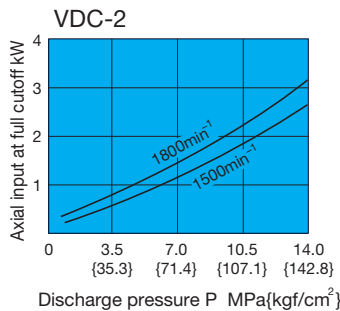
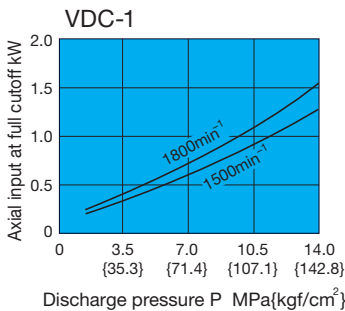

Noise Characteristics

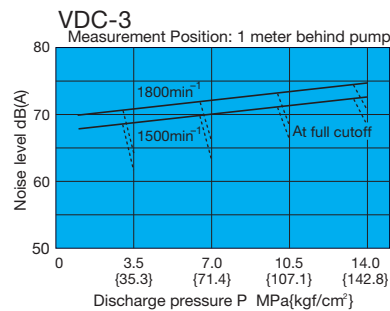
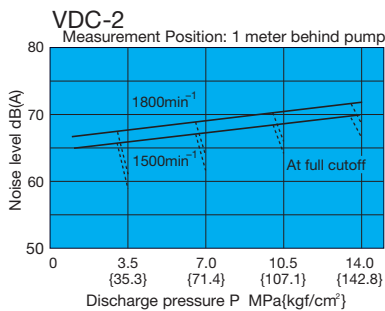
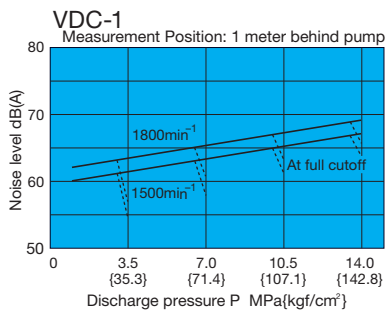

Cross-sectional Drawings

VDC-1A-*A*-20

VDC-2A-*A*-20

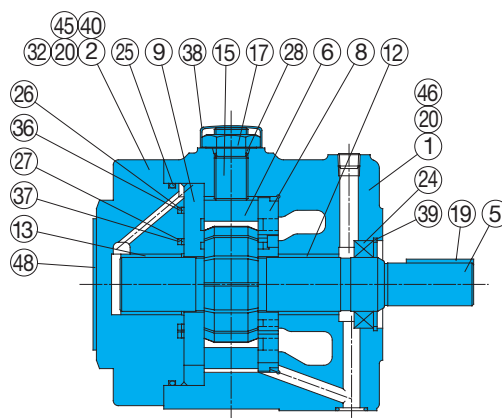
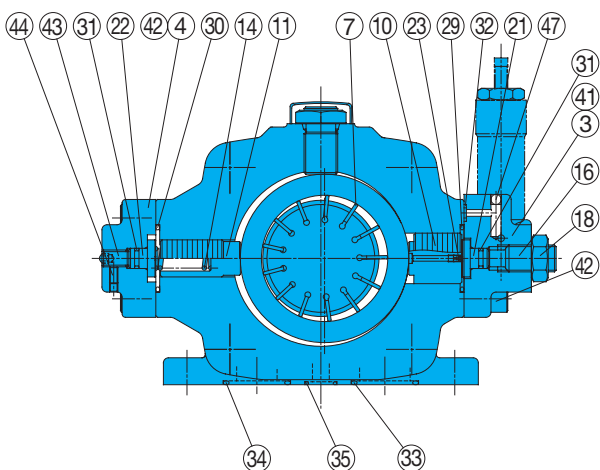

Seal Component Table (VDC-1*,VDC-2*)

Part No.	Applicable Pump Model No.	VDC-1A-*A*-20		VDC-2A-*A*-20	
	Seal Kit Number	VCBS-101A00		VCBS-102A00	
	Part Name	Part Number	Q'ty	Part Number	Q'ty
24	Oil seal	TCV-224211-V	1	TCN-325211-V	1
25	O-ring	S85(NOK)	1	NBR-70-1 G115	1
26	O-ring	AS568-034	1	AS568-150	1
27	O-ring	AS568-026	1	AS568-134	1
28	O-ring	NBR-70-1 P14	1	NBR-70-1 P18	1
29	O-ring	NBR-70-1 P22	1	NBR-70-1 G35	1
30	O-ring	NBR-70-1 P20	1	NBR-70-1 G35	1
31	O-ring	NBR-70-1 P5	2	NBR-70-1 P9	2
32	O-ring	NBR-70-1 P6	4	NBR-70-1 P7	4
33	O-ring	NBR-70-1 P25	1	NBR-70-1 G35	1
34	O-ring	NBR-70-1 P22	1	NBR-70-1 G35	1
35	O-ring	NBR-70-1 P10A	1	NBR-70-1 P15	1
36	Backup ring	VCB34-101000	1	VCB34-102000	1
37	Backup ring	VCB34-201000	1	VCB34-202000	1
57	O-ring	NBR-70-1 P14	1	NBR-70-1 P14	1
58	O-ring	NBR-90 P6	3	NBR-90 P6	3

- Note) 1. Oil seals are manufactured by Nippon Oil Seal Industry Co. Ltd. (NOK).
 2. The materials and hardness of the O-ring conform with JIS B2401.
 3. For VDR-*B*-20, the seal kit number becomes VDDBS-10*B00, without the 33, 24, and 35 O-rings.

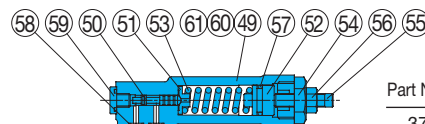

Part No.	Part Name	Part No.	Part Name	Part No.	Part Name
1	Body (1)	19	Key	37	Backup ring
2	Body (2)	20	Pin	38	Cap
3	Cover (1)	21	Holder	39	Snap ring
4	Cover (2)	22	Holder	40	Screw
5	Shaft	23	Orifice	41	Screw
6	Ring	24	Oil seal	42	Screw
7	Vane	25	O-ring	43	Screw (stopper)
8	Plate (S)	26	O-ring	44	Screw
9	Plate (H)	27	O-ring	45	Plug
10	Piston (1)	28	O-ring	46	Plug
11	Piston (2)	29	O-ring	47	Pole
12	Bearing	30	O-ring	48	Nameplate
13	Bearing	31	O-ring	49	Valve body
14	Spring	32	O-ring	50	Spool
15	Thrust screw	33	O-ring	51	Holder
16	Screw	34	O-ring	52	Plunger
17	Nut	35	O-ring	53	Spring
18	Nut	36	Backup ring	54	Retainer
				55	Screw
				56	Nut
				57	O-ring
				58	O-ring
				59	Plug
				60	Plug
				61	Screw

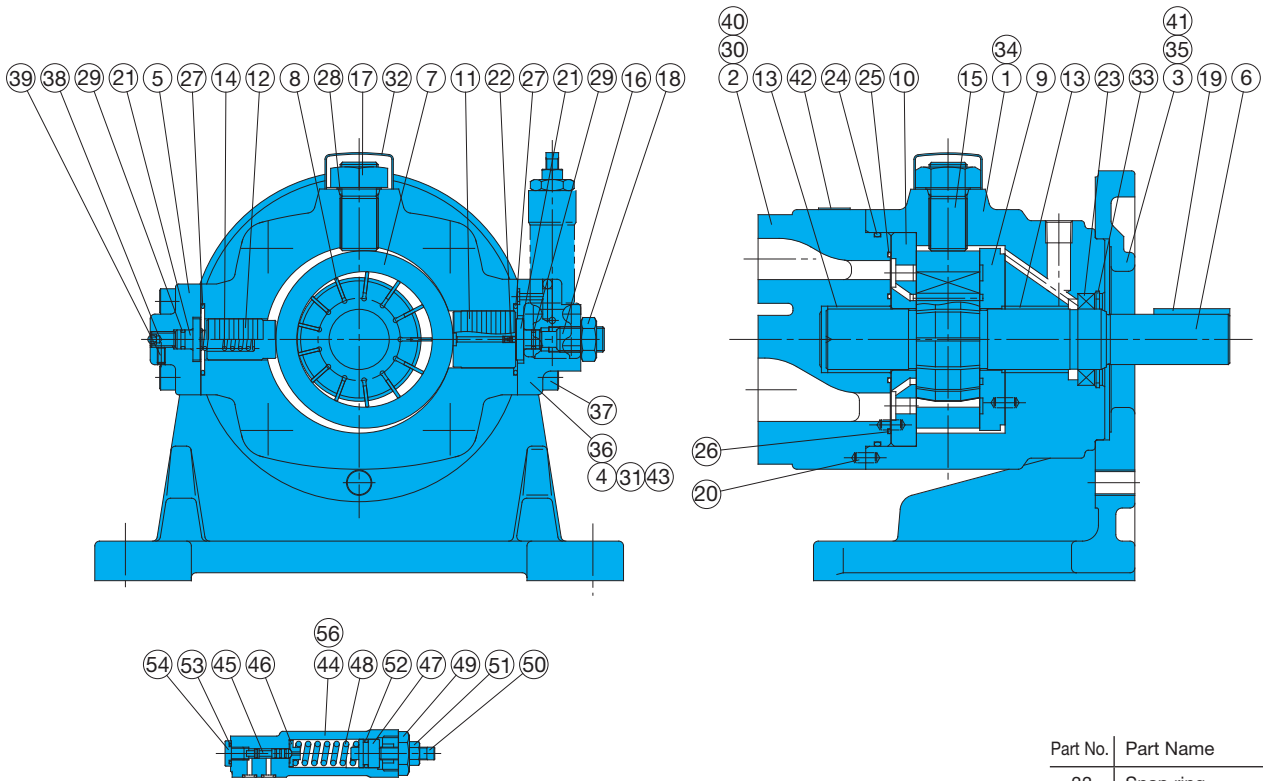

Part No.	Part Name
33	Snap ring
34	Screw
35	Screw
36	Screw
37	Screw
38	Screw (stopper)
39	Screw
40	Plug
41	Washer
42	Nameplate
43	Pole
44	Valve body
45	Spool
46	Holder
47	Plunger
48	Spring
49	Retainer
50	Screw
51	Nut
52	O-ring
53	O-ring
54	Plug
55	Plug
56	Screw

Seal Component Table (VDC-3*)

Part No.	Applicable Pump Model No.		Q'ty
	Seal Kit Number	Part Number	
	VDC-3A(B)*-20		
	VCBS-103B00		
Part No.	Part Name	Part Number	Q'ty
23	Oil seal	TCN-385811-V	1
24	O-ring	NBR-70-1 G130	1
25	O-ring	AS568-154(NBR-90)	1
26	O-ring	AS568-151(NBR-90)	1
27	O-ring	NBR-70-1 G40	2
28	O-ring	NBR-70-1 P22	1
29	O-ring	NBR-70-1 P9	2
30	O-ring	NBR-70-1 P7	2
31	O-ring	NBR-70-1 P7	2
52	O-ring	NBR-70-1 P14	1
53	O-ring	NBR-90 P6(NBR-90)	3

Part No.	Part Name	Part No.	Part Name
1	Body (1)	17	Nut
2	Body (2)	18	Nut
3	Mounting	19	Key
4	Cover (1)	20	Pin
5	Cover (2)	21	Holder
6	Shaft	22	Orifice
7	Ring	23	Oil seal
8	Vane	24	O-ring
9	Plate (S)	25	O-ring
10	Plate (H)	26	O-ring
11	Piston (1)	27	O-ring
12	Piston (2)	28	O-ring
13	Bearing	29	O-ring
14	Spring	30	O-ring
15	Thrust screw	31	O-ring
16	Screw	32	Cap

Note) 1. Oil seals are manufactured by Nippon Oil Seal Industry Co. Ltd. (NOK).
 2. The materials and hardness of the O-ring conform with JIS B2401.

VDC Series
Double Pump

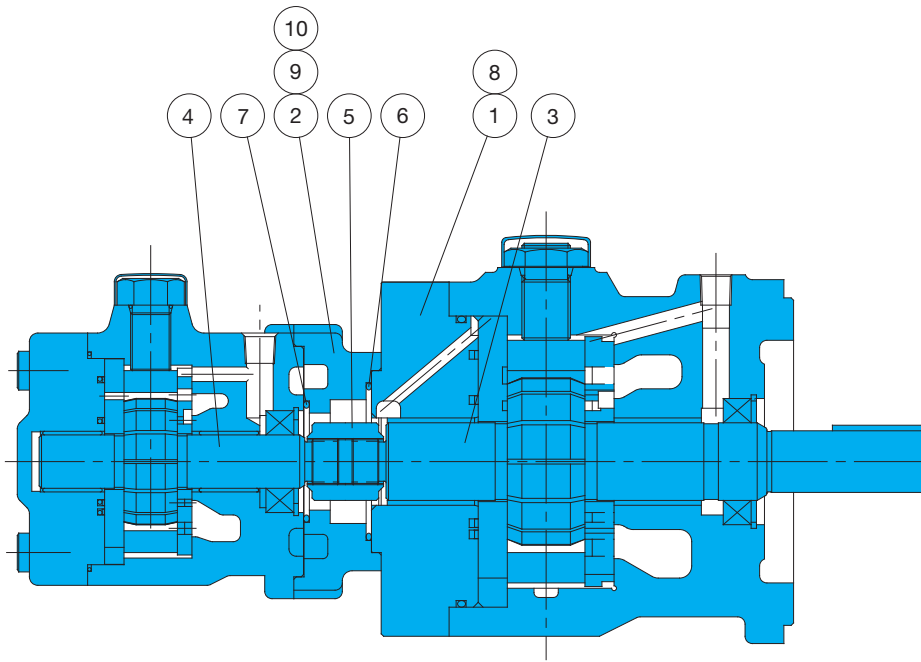

Part No.	Part Name
1	Body (2)
2	Body (3)
3	Shaft (S)
4	Shaft (H)
5	Joint
6	O-ring
7	O-ring
8	Screw
9	Screw
10	Screw

Note) In the case of a double pump, use single pump parts in addition to the 10 parts listed above.

List of Sealing Parts

Part No.	Part Name	VDC-11A-*-*-20		VDC-12A-*-*-20		VDC-22A-*-*-20		VDC-13A-*-*-20	
		Part Number	Q'ty	Part Number	Q'ty	Part Number	Q'ty	Part Number	Q'ty
6	O-ring	-		NBR-70-1 G60	1	NBR-70-1 G60	1	-	
7	O-ring	NBR-70-1 G85	1	NBR-70-1 G45	1	NBR-70-1 G60	1	NBR-70-1 G85	1

Note) 1. See the description of the single pump for seal parts that are not included in the list.
2. The materials and hardness of the O-ring conform with JIS B2401.

Foot Mounting Installation Measurement Chart

For VDC-11A, VDC-12 and VDC-22 (for double pump)

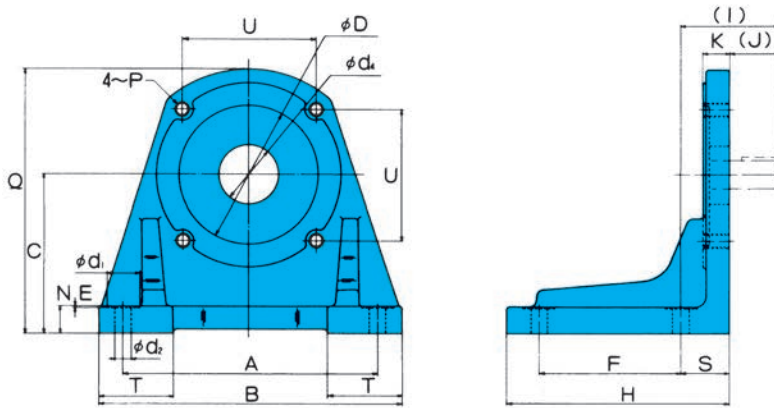

For VDC-3A and VDC-13A

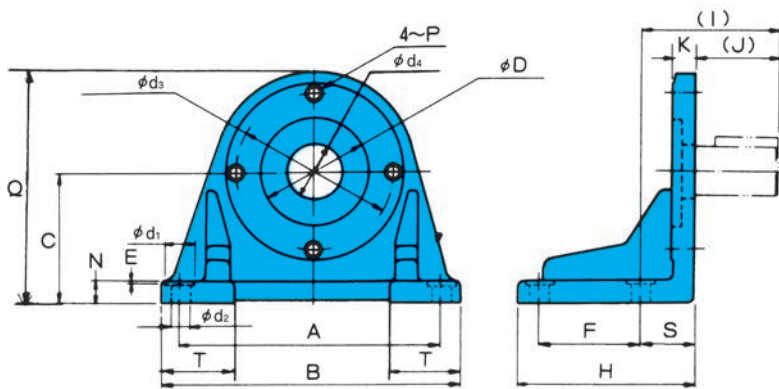

Foot Mounting Kit Model No.	Applicable Pump Model No.	Accessories				Dimensions mm					
		Bolt	Q'ty	Washer	Q'ty	A	B	C	E	F	H
VCM-11-20	VDC-1 VDC-11	TH-10×30	4	WS-B-10	4	171.45	204	107.95	1	95.25	150
VCM-22-20	VDC-2 VDC-12 VDC-22	TH-12×35	4	WS-B-12	4	235	267	139.7	1	127	193
IHM-45-10	VDC-3 VDC-13	TB-16×40	2	WP-16	2	295.3	334	152.4	1	139.7	203

Foot Mounting Kit Model No.	Dimensions mm															Weight kg
	(I)	(J)	K	N	P	Q	S	T	U	φ D	φ d ₁	φ d ₂	φ d ₃	φ d ₄		
VCM-11-20	66.5	33	18	18	M10	180	32.5	50	90	95.02	22	11	-	40	6.5	
VCM-22-20	84.5	40	20	20	M12	232	44.5	57.5	124	135	22	14	-	40	12.0	
IHM-45-10	104.5	60	25	25	M16	259	44.5	61	-	127	35	18	181	86	13.5	

Uni-pump Specifications

(CE mark standard compliant)

Single Pump

UVC - 1 A - 2 A 2 - 1.5 - 4 - 40

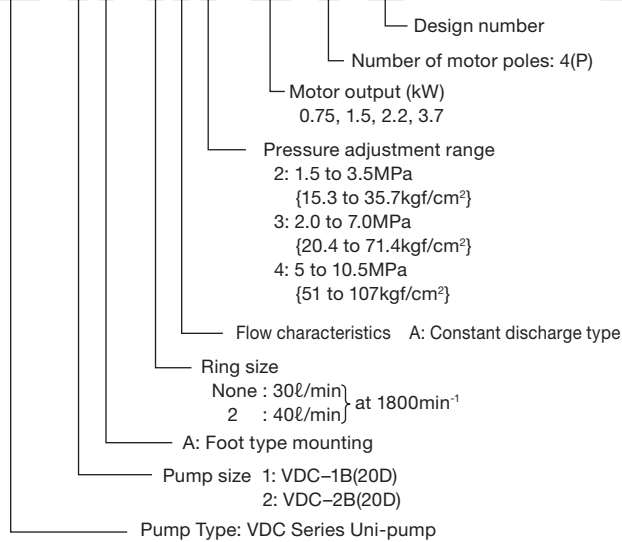

Double Pump

UVC - 11 A - 2 A 2 - 2 A 2 - 3.7 - 4 - 40

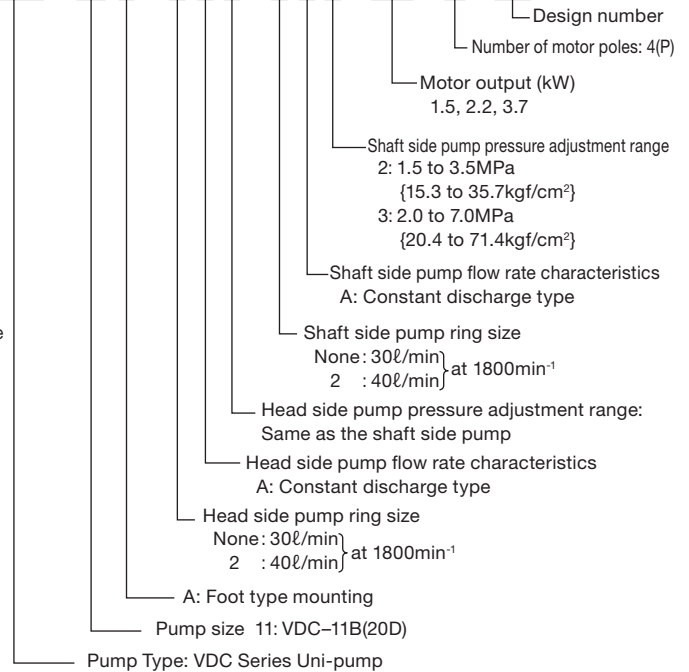

Specifications

Model No.	Maximum Working Pressure MPa{kgf/cm²}	Maximum Flow Rate ℓ/min (A*)		Maximum Flow Rate ℓ/min (2A*)	
		50Hz	60Hz	50Hz	60Hz
UVC- 1A	7 {71.4}	25	30	33	40
UVC- 2A	7 {71.4}	45	54	58	70
UVC-11A	7 {71.4}	25-25	30-30	33-33	40-40

Motor selection curves

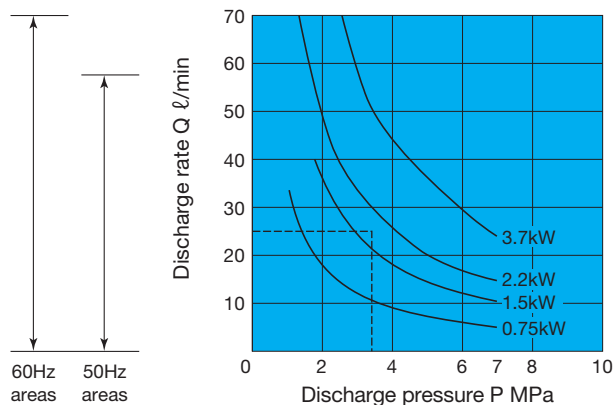

● Selecting a motor

The area under a motor output curve in the graph to the left is the operating range for that motor under the rated output for that motor.

Example:

To find the motor that can produce pressure of 3.5MPa and a discharge rate of 25.0 ℓ/min. Selection Process

Since the intersection of the two broken lines from a pressure of 3.5MPa and discharge rate of 25.0 ℓ/min intersect in the area under the 2.2kW curve, it means that a 2.2kW motor should be used. In the case of a double pump configuration, select a motor that is larger than the total power required by both pumps.

* Select a uni-pump that has a pressure and flow rate that is within the range of the drive so that the drive will not overload.

* When the startup current of the uni-pump becomes higher for the IE1 motor, breakers may need to be changed.

Installation Dimension Drawings

UVC-1A

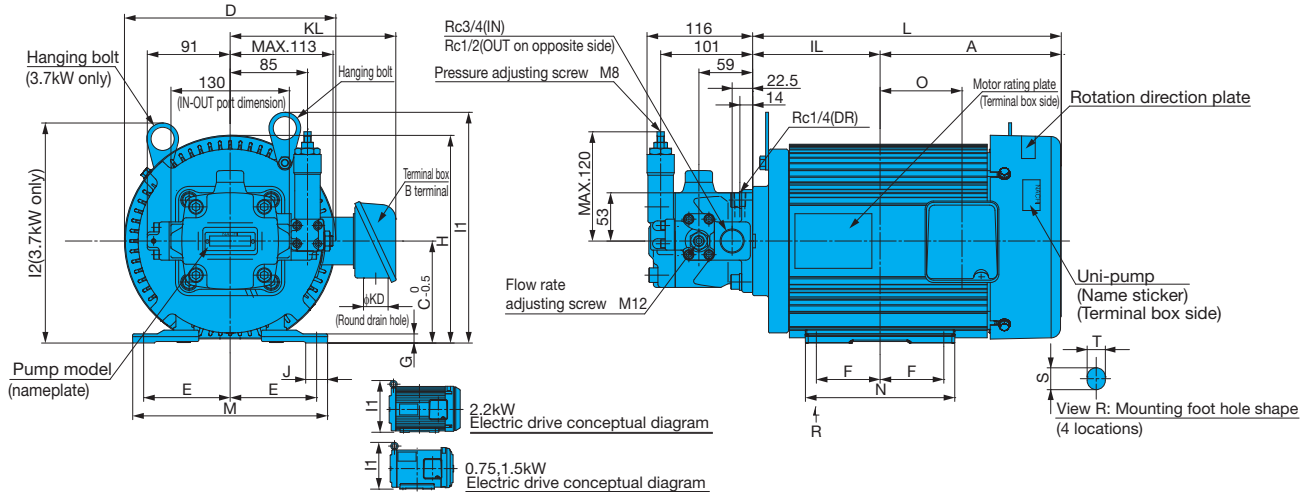

Uni-pump	Motor Dimensions [mm]																	Frame No.	Output kW (4 poles)	Weight kg		
	A	IL	C	D	E	F	G	H	I1	I2	J	L	M	N	SxT	φ KD	KL				O	
UVC-1A-A2-0.75-4-40	137	105	80	152	62.5	50	4.5	160	193	-	47.5	242	165	130	25x10	27	137	65	80M	0.75	28.5	
UVC-1A-A2-1.5-4-40																						
UVC-1A-A3-1.5-4-40	160.5	118.5	90	183	70	62.5	4.4	183	204	-	22	279	165	152.5	16x10	27	142	68	90L	1.5	31.5	
UVC-1A-2A2-1.5-4-40																						
UVC-1A-A2-2.2-4-40																						
UVC-1A-A3-2.2-4-40	179	133	100	206	80	70	7	203	226	-	39	312	206	170	14x12	27	153	83	100L	2.2	45.5	
UVC-1A-2A2-2.2-4-40																						
UVC-1A-A3-3.7-4-40																						
UVC-1A-A4-3.7-4-40	199	140	112	233	95	70	10	228	253	242	24	339	214	164	14x12	27	182	90	112M	3.7	49.5	
UVC-1A-2A2-3.7-4-40																						
UVC-1A-2A3-3.7-4-40																						

1. Standard drive motor is the fully enclosed fan-cooled F type.
2. Standard voltage for drive motor is 200 VAC, 50/60 Hz or 220 VAC, 60 Hz.
3. Standard terminal box is B terminal (right side viewed from pump).
4. See page A-21 for the characteristics of the drive motor for the unipump (domestic standard 3 rating).

UVC-2A

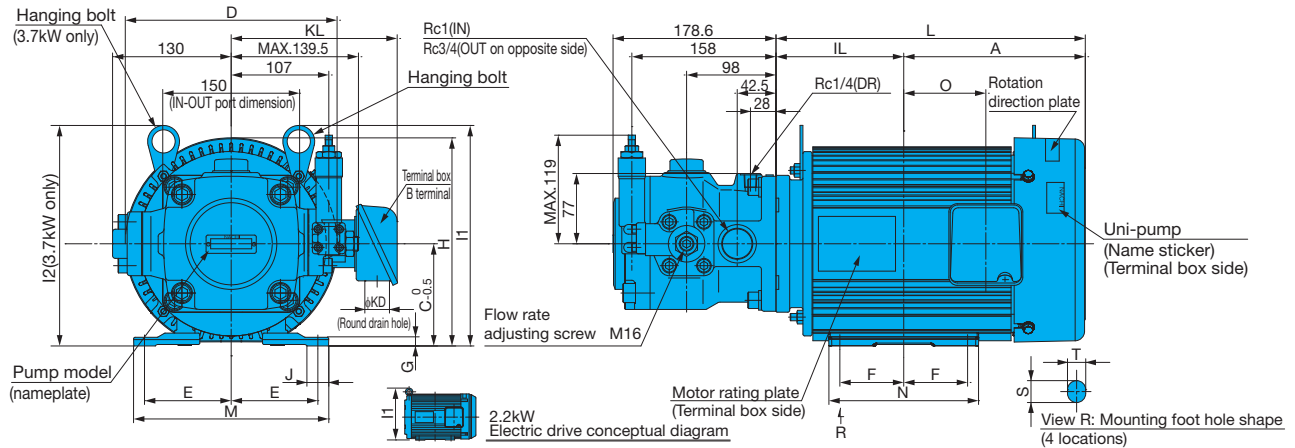

Uni-pump	Motor Dimensions [mm]																	Frame No.	Output kW (4 poles)	Weight kg		
	A	IL	C	D	E	F	G	H	I1	I2	J	L	M	N	SxT	φ KD	KL				O	
UVC-2A-A2-2.2-4-40	179	133	100	206	80	70	7	203	226	-	39	312	206	170	14x12	27	153	83	100L	2.2	61	
UVC-2A-A3-2.2-4-40																						
UVC-2A-A2-3.7-4-40																						
UVC-2A-A3-3.7-4-40	199	140	112	233	95	70	10	228	253	242	24	339	214	164	14x12	27	182	90	112M	3.7	65	
UVC-2A-2A2-3.7-4-40																						
UVC-2A-2A3-3.7-4-40																						

1. Standard drive motor is the fully enclosed fan-cooled F type.
2. Standard voltage for drive motor is 200 VAC, 50/60 Hz or 220 VAC, 60 Hz.
3. Standard terminal box is B terminal (right side viewed from pump).
4. See page A-21 for the characteristics of the drive motor for the unipump (domestic standard 3 rating).

UVC-11A

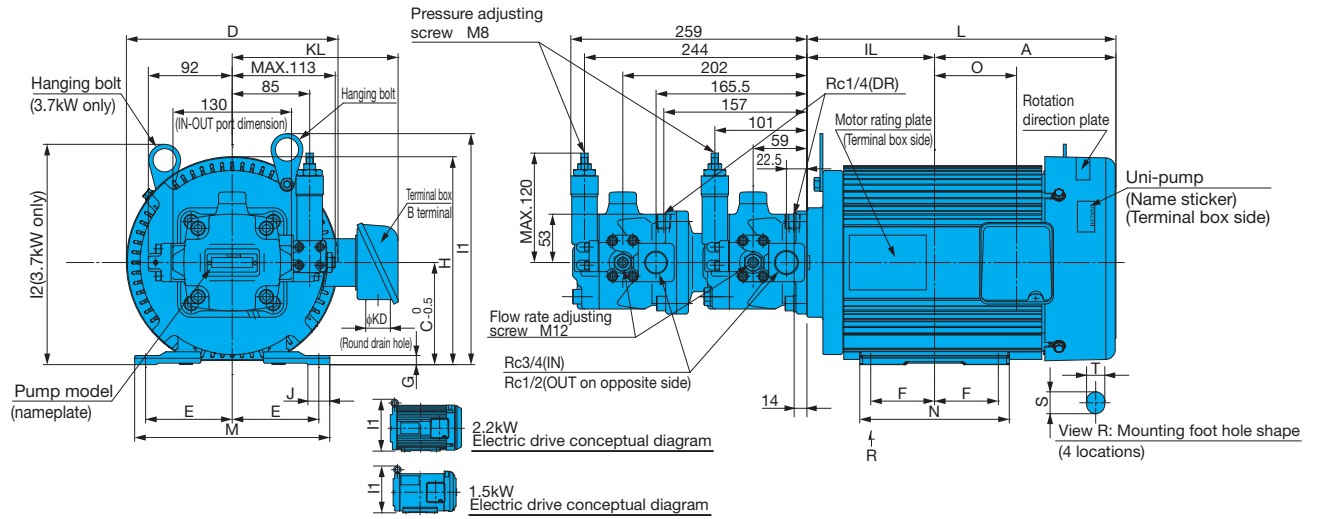

Uni-pump	Motor Dimensions [mm]																	Frame No.	Output kW (4 poles)	Weight kg		
	A	IL	C	D	E	F	G	H	I1	I2	J	L	M	N	S×T	φKD	KL				O	
UVC-11A-A2-A2-1.5-4-40																				90L	1.5	42
UVC-11A-A2-A3-1.5-4-40	160.5	118.5	90	183	70	62.5	4.4	183	204	-	22	279	165	152.5	16×10	27	142	68	90L	1.5	42	
UVC-11A-A3-A3-1.5-4-40																						
UVC-11A-A2-A2-2.2-4-40																						
UVC-11A-A2-A3-2.2-4-40	179	133	100	206	80	70	7	203	226	-	39	312	206	170	14×12	27	153	83	100L	2.2	56	
UVC-11A-2A2-2A2-2.2-4-40																						
UVC-11A-A2-A2-3.7-4-40																						
UVC-11A-A2-A3-3.7-4-40																						
UVC-11A-A3-A3-3.7-4-40	199	140	112	233	95	70	10	228	253	242	24	339	214	164	14×12	27	182	90	112M	3.7	60	
UVC-11A-2A2-2A2-3.7-4-40																						
UVC-11A-2A2-2A3-3.7-4-40																						

1. Standard drive motor is the fully enclosed fan-cooled F type.
2. Standard voltage for drive motor is 200 VAC, 50/60 Hz or 220 VAC, 60 Hz.
3. Standard terminal box is B terminal (right side viewed from pump).
4. See page A-21 for the characteristics of the drive motor for the unipump (domestic standard 3 rating).