



Pilot Operated Check Modular Valve

50 to 300ℓ/min
25,35MPa

Features

- ① This modular valve is used to prevent actuator self-running and to maintain actuator position.
- ② Maximum Operating Pressure: 25, 35MPa {255, 357kgf/cm²}

Specifications

Model No.	Nominal Diameter (Size)	Maximum Working Pressure MPa{kgf/cm ² }	Maximum Flow Rate ℓ/min	Cracking pressure MPa{kgf/cm ² }	Area Ratio			Weight kg	Gasket Surface Dimensions
					Pilot Piston	Check Valve Seat	Needle Valve Seat		
OCP-G01-W1-21 W2	1/8	25 {255}	50	0.2 {2.0}	1	0.37	-	1.2	ISO 4401-03-02-0-05
OCP-G01-A1-21 A2				0.5 {5.1}					
OCP-G01-B1-21 B2				0.2 {2.0}					
OCP-G01-W1-F-21 W2				0.5 {5.1}					
OCP-G01-A1-F-21 A2				0.2 {2.0}					
OCP-G01-B1-F-21 B2				0.5 {5.1}					
OCP-G03-W1-J50 W2	3/8	25 {255}	100	0.2 {2.0}	1	0.49	0.07	3.6	ISO 4401-05-04-0-05
OCP-G03-A1-J50 A2				0.5 {5.1}					
OCP-G03-B1-J50 B2				0.2 {2.0}					
OCP-G03-W1-D-J50 W2				0.5 {5.1}					
OCP-G03-A1-D-J50 A2				0.2 {2.0}					
OCP-G03-B1-D-J50 B2				0.5 {5.1}					
OPH-G04-W1-10 W2	1/2	35 {357}	300	0.2 {2.0}	1	0.50	0.07	6.8	ISO 4401-07-06-0-05
OPH-G04-A1-10 A2				0.5 {5.1}					
OPH-G04-B1-10 B2				0.2 {2.0}					
OPH-G04-W1-D-10 W2				0.5 {5.1}					
OPH-G04-A1-D-10 A2				0.2 {2.0}					
OPH-G04-B1-D-10 B2				0.5 {5.1}					

● Handling

- ① Note that when the 01 size has the auxiliary symbol "F," tank port back pressure can cause the small valve to open, making it impossible to maintain pressure.
- ② If tank port back pressure causes the small valve to open and make it impossible to maintain pressure with the 03, 04 size, use a direct type with auxiliary symbol "D."
- ③ Minimum pilot pressure fluctuates with the input side pressure during reverse flow. Operate the valve so pressure is at least twice as high as the required pressure obtained using the minimum pilot pressure characteristics graph.
- ④ Note that a sub plate and installation bolts are not included. See pages D-90 through D-95 if these items are required.
- ⑤ 04 series modular valves do not have an L (DR₂) drain port, so they cannot be used in combination with pressure center type solenoid valves (D).

Explanation of model No.

01, 03 size

OCP - G 03 - W 1 - (D) - J50

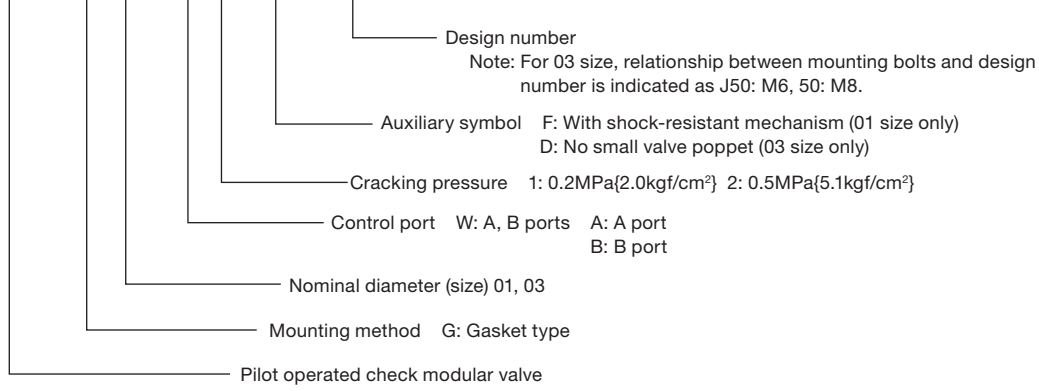

Explanation of model No.

04 size

OPH - G 04 - W 1 - (D) - 10

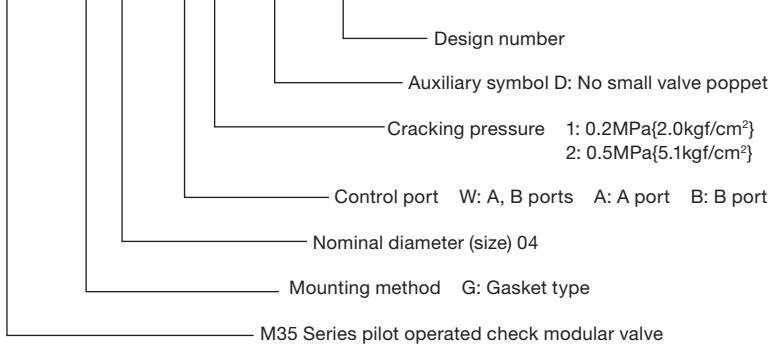

Installation Dimension Drawings

OCP-G01-**-F)-21

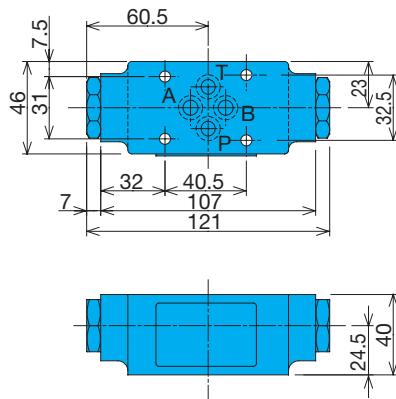

OCP-G03-**-D)-J50

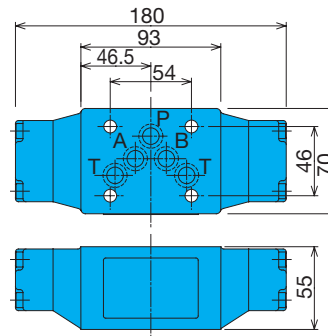

OPH-G04-**-D)-10

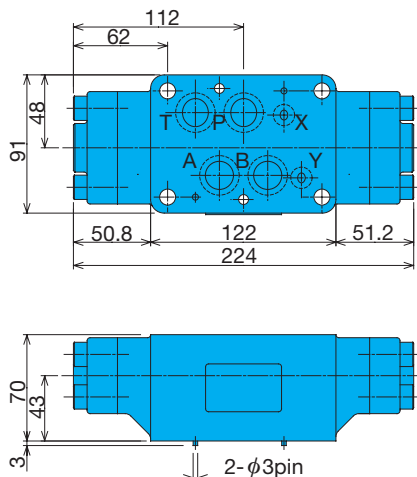

Performance Curves

Hydraulic Operating Fluid Kinematic Viscosity 32mm²/s

Pressure Loss Characteristics

OCP-G01-W*-21

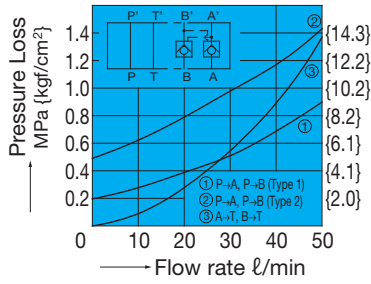

OCP-G01-W*-F-21

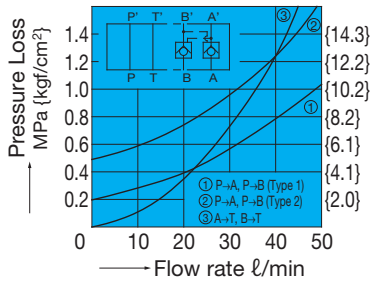

OCP-G03-W*-(D)-J50

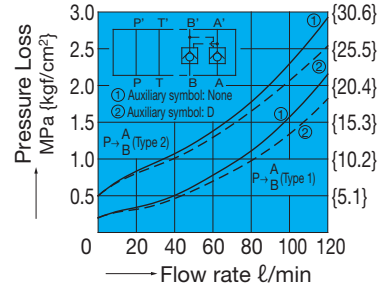

Pressure Loss Characteristics (Reverse Free Flow)

OCP-G03-W*-J50

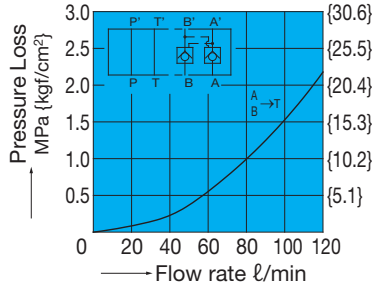

OPH-G04-W*-10

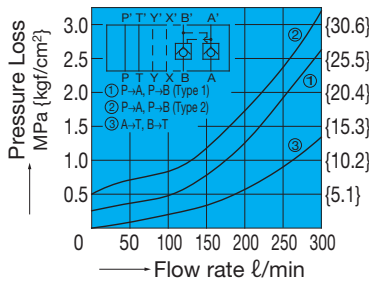

Minimum Pilot Pressure Characteristics

OCP-G01-**-21

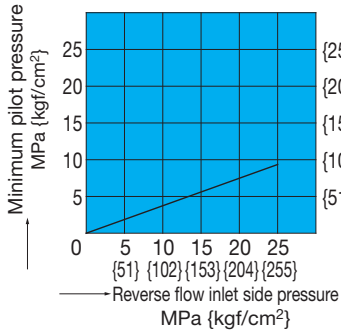

OCP-G01-**-F-21

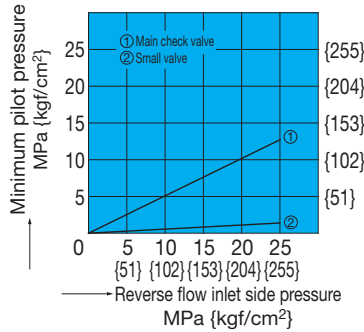

OCP-G03-W*-(D)-J50

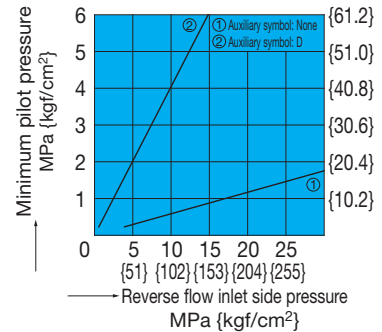

OPH-G04-W*-(D)-10

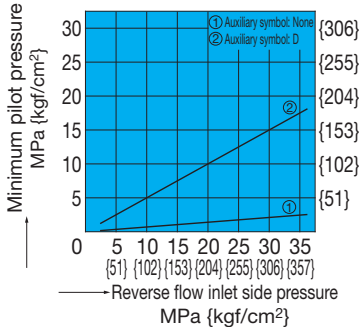

Cross-sectional Drawings

OCP-G01-A*-21

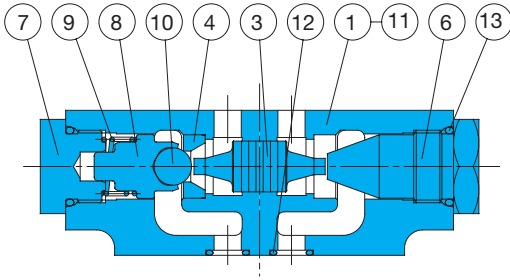

OCP-G01-A*-F-21

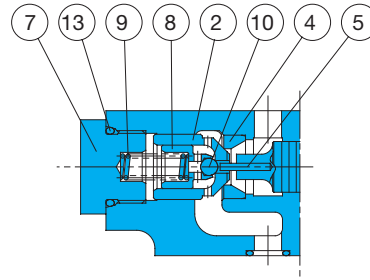

Part No.	Part Name
1	Body
2	Poppet
3	Piston
4	Seat
5	Rod
6	Bushing
7	Spring seat
8	Guide
9	Spring
10	Ball
11	Plate
12	O-ring
13	O-ring

Seal Part List (Kit Model Number BDBS-01CP*-0A)

Part No.	Part Name	Part Number	Q'ty		
			W	A	B
12	O-ring	AS568-012(NBR-90)	4	4	4
13	O-ring	NBR-90 P18	2	2	2

Note) 1. The materials and hardness of the O-ring conform with JIS B2401.
2. Specify W, A, or B for the asterisk (*) in the kit model number.

OCP-G03-A*-J50

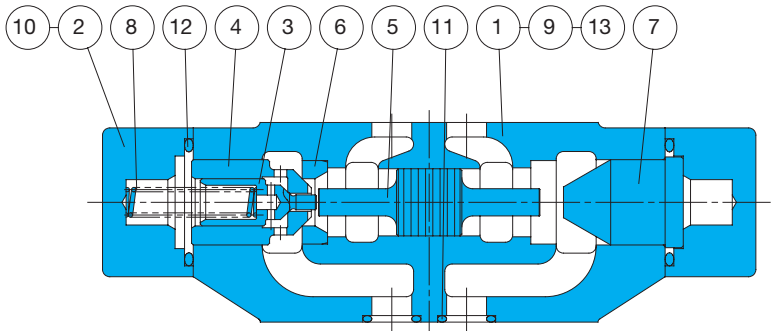

Part No.	Part Name
1	Body
2	Cover
3	Poppet
4	Poppet
5	Piston
6	Seat
7	Bushing
8	Spring
9	Plate
10	Screw
11	O-ring
12	O-ring
13	Pin

OCP-G03-**-D-J50

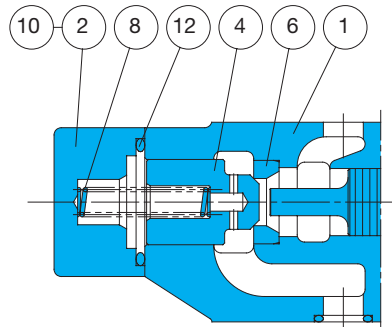

Seal Part List (Kit Model Number BDES-03CP*)

Part No.	Part Name	Part Number	Q'ty		
			W	A	B
11	O-ring	AS568-014(NBR-90)	5	5	5
12	O-ring	NBR-90 P29	2	2	2

Note) 1. The materials and hardness of the O-ring conform with JIS B2401.
2. Specify W, A, or B for the asterisk (*) in the kit model number.

OPH-G04-A*-10

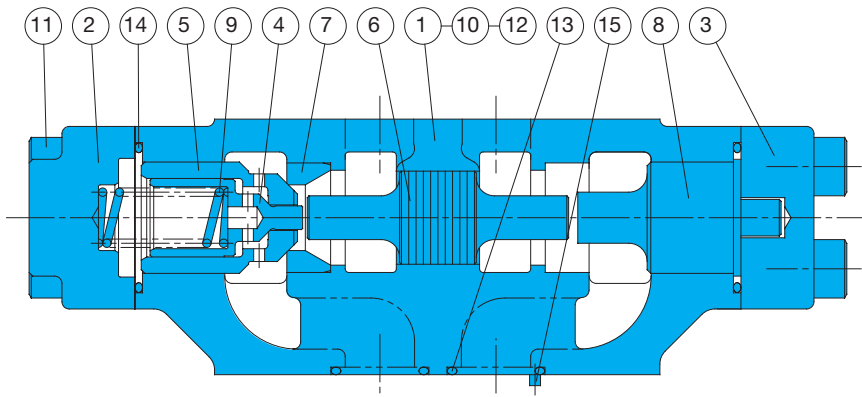

Part No.	Part Name
1	Body
2	Cover
3	Cover
4	Poppet
5	Poppet
6	Piston
7	Seat
8	Bushing
9	Spring
10	Plate
11	Screw
12	O-ring
13	O-ring
14	O-ring
15	Pin

OPH-G04-**-D-10

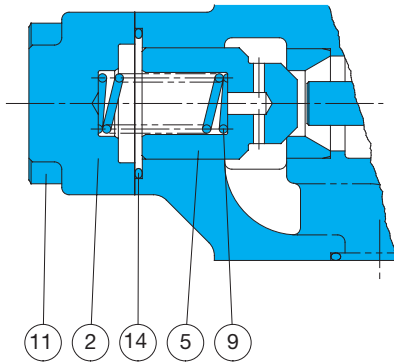

Seal Part List (Kit Model Number BDKS-04CP*)

Part No.	Part Name	Part Number	Q'ty		
			W	A	B
12	O-ring	AS568-012(NBR-90)	2	2	2
13	O-ring	AS568-118(NBR-90)	4	4	4
14	O-ring	AS568-127(NBR-90)	2	2	2

Note) Specify W, A, or B for the asterisk (*) in the kit model number.