

Fine Solenoid Valve SF Series

10 to 40ℓ/min
21MPa

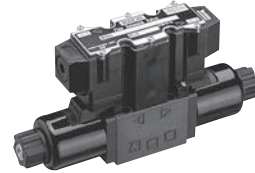

Features

- ① The function of two valves in one
A two-speed controller provides smooth speed adjustment from low speed to high, and from high-speed to low.
- ② Quiet starts and stops
A low-speed startup and stop feature makes startups and stops smooth and soft.
- ③ Separate control of forward and back cylinder movement
There are five volume settings for high-speed flow rate and acceleration/deceleration times that can be independently adjusted SOL.a and SOL.b (ON side, OFF side).

Specifications

Item	Model No.	SF-G01 -C*10-D2-10	SF-G01 -C*20-D2-10	SF-G01 -C*40-D2-10
Valve Maximum Operating Pressure MPa(kgf/cm ²)		21{214}		
Maximum Flow Rate ℓ/min(Note1)		10	20	40
High-speed Flow Rate ℓ/min(Note1)		5 to 10	10 to 20	20 to 40
Low-speed Flow Rate ℓ/min(Note1)		0.5 to 4	2 to 8	4 to 16
Maximum Allowable Pressure MPa(kgf/cm ²)		7{71}		
Acceleration/Deceleration Time Adjustment Range SEC		0.1 to 2		
Hysteresis (Note 2)		7%		
Repeatability (Note 2)		3%		
Power Supply Voltage V		D2: 24V DC regulated DC power supply		
Maximum Power Consumption W		36W		
Operating Environment	Dust Resistance/Water Resistance Rank	JIS C 0920 IP63(Dust-tight, Rain-proof)		
	Ambient Temperature	5 to 50°C		
	Operating Fluid	Temperature Range	5 to 60°C	
		Kinematic Viscosity Range	15 to 300mm ² /s	
Mounting	Filtration	25 μm or less		
	Size x Length	M5x45 (four)		
	Tightening Torque	5 to 7N·m{51 to 71kgf·cm}		

- Note) 1. The above high-speed and low-speed flow rates are obtained with a differential pressure (PA, PB) of 1.0MPa {10.2kgf/cm²}. The flow rates depend on differential pressure.
 2. Hysteresis and repeatability values are those at maximum flow rate.
 3. For mounting bolts, use bolts of 12.9 strength classification or equivalent.
 4. Mounting bolts are not included.

Explanation of model No.

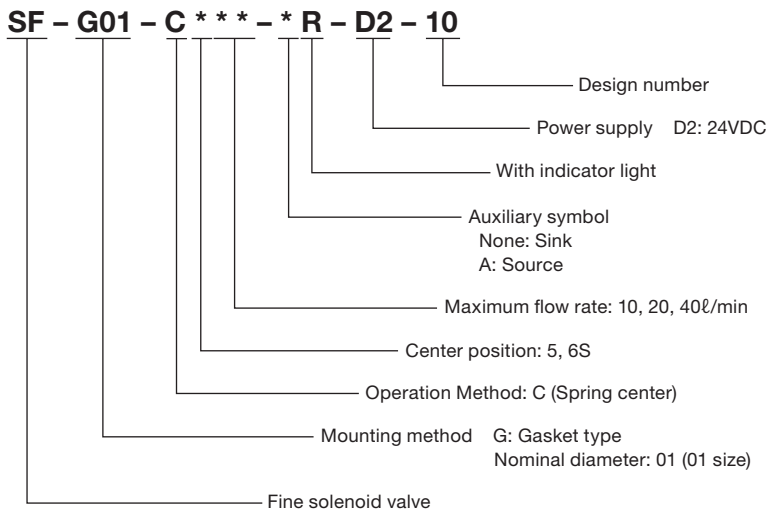

● Handling

- ① Valve differential pressure
Volume adjustment becomes sensitive when P→A (B) and B(A)→T differential pressure is large. Maintain the pressure differential so it is no greater than 3.5MPa {35.7kgf/cm²}.
- ② Low-speed flow rate
The spool may not move if the low-speed flow rate is below the minimum. Use this valve only within the allowable minimum low-speed flow rate range.
- ③ Deceleration circuit
• Use a C5** spool for the deceleration circuit. Deceleration is difficult with the C6S** spool.
• When large deceleration is required or for a system that uses a vertical cylinder, equip an external drain type counter balance valve. See the illustration below.
- ④ Pilot check circuit
• For a circuit with a pilot check valve, knocking may occur in the pilot check valve due to large load inertia and circuit pressure loss. In cases like this, use an external drain type pilot check valve. See the illustration below.

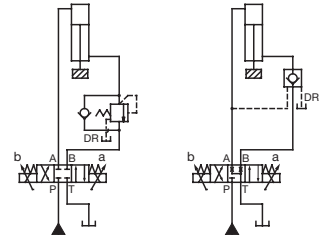

When large brake pressure is required
(Use an external drain type counter valve.)

When there is the possibility of pilot check valve knocking
(Use an external drain type pilot check valve.)

⑤ Environmental conditions

- The IC circuit board is located inside the central control box, so care must be exercised concerning water-resistance and ambient temperature.
- Water: Cover the box so there is no direct splashing with water.
- Ambient Temperature: Use in an area where the temperature is 5°C to 50°C.

⑥ Operating Fluid

- Always keep the operating fluid clean. Allowable contamination is class NAS11 or less.
 - Use oil-based hydraulic operating fluid.
 - Contact your agent when you want to use fire-resistant hydraulic fluid.
- (Continued on following page)



7] Note the following points to optimize operation.

- (1) Control oil temperature when using this valve. Since the valve perform restrictor valve control on all processes, temperature differential changes flow volume and acceleration/deceleration time. The recommended temperature range is 30°C to 60°C.
- (2) During the positioning operation following deceleration, make sure

that sufficient low-speed running is provided following deceleration before stopping operation. If low-speed operation time is too short

can cause stopping during deceleration and shock problems due to fluctuation in load, etc.

Spool Type and JIS Symbols

Spool Type	C5**	C6S**
JIS Symbol		

Electrical Wiring

● Sink Type (Auxiliary Symbol: None)
Switches on load and power supply minus side

● Source Type (Auxiliary Symbol: A)
Switches on load and power supply plus side

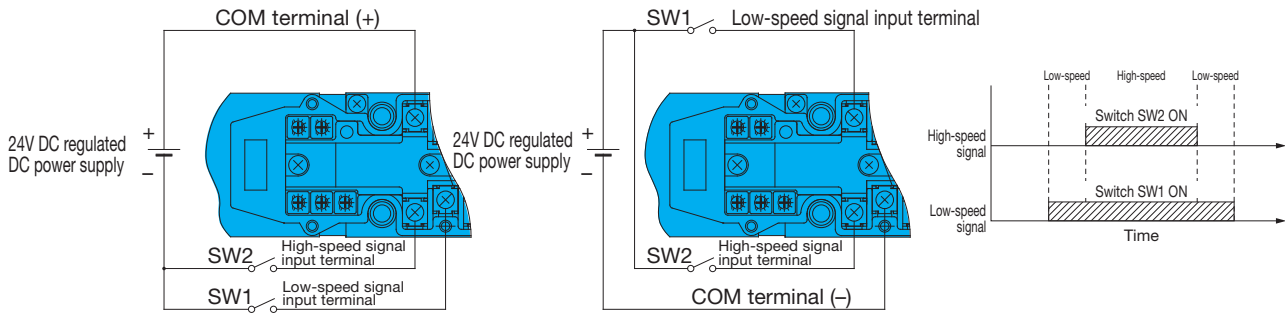

Adjustment Elements

Control Pattern

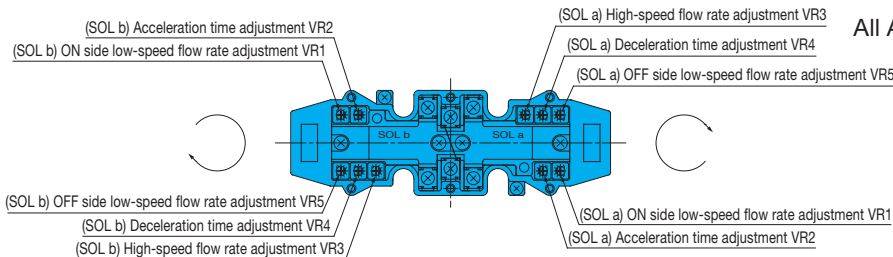
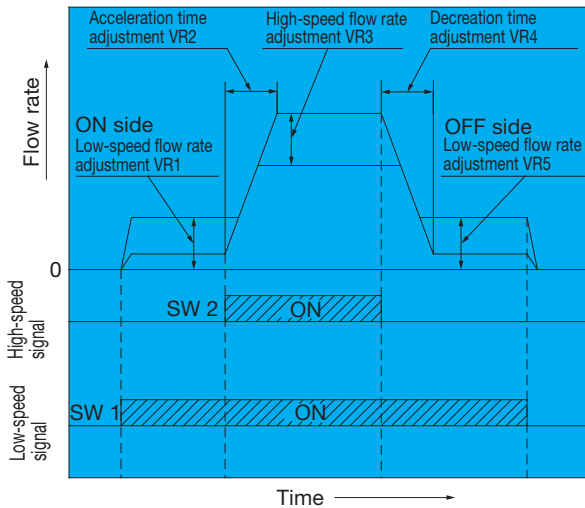

Electrical Control Precautions

- Do not introduce a high-speed signal prior to a low-speed signal. Make sure the two signals are introduced simultaneously or that the low-speed signal is introduced first.
- (1) Repeatedly introducing the high-speed signal first in a source type configuration can damage the IC board.
- (2) The valve will not operate on the high-speed signal only.
- The following adjustments in the range of VR1 through VR5 can be made independently for SOL.a and SOL.b. You can make adjustments for the best conditions for forward and back operations when considering the cylinder operations.
- Adjustment volume is arranged in from VR1 through VR5 in clockwise (rightward) rotation sequence when viewed from the coil side.
- The following are the factory default volume settings.

- VR1·2·4·5 — Minimum setting
- VR3 — Maximum setting

All Adjustment VRs

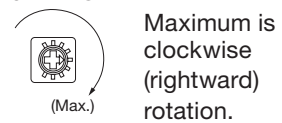

- The volume rotation angle is 270°. Contact your agent about a three-rotation type adjuster for fine adjustment.

Installation Dimension Drawings

SF-G01-C***-(A)R-D2-10

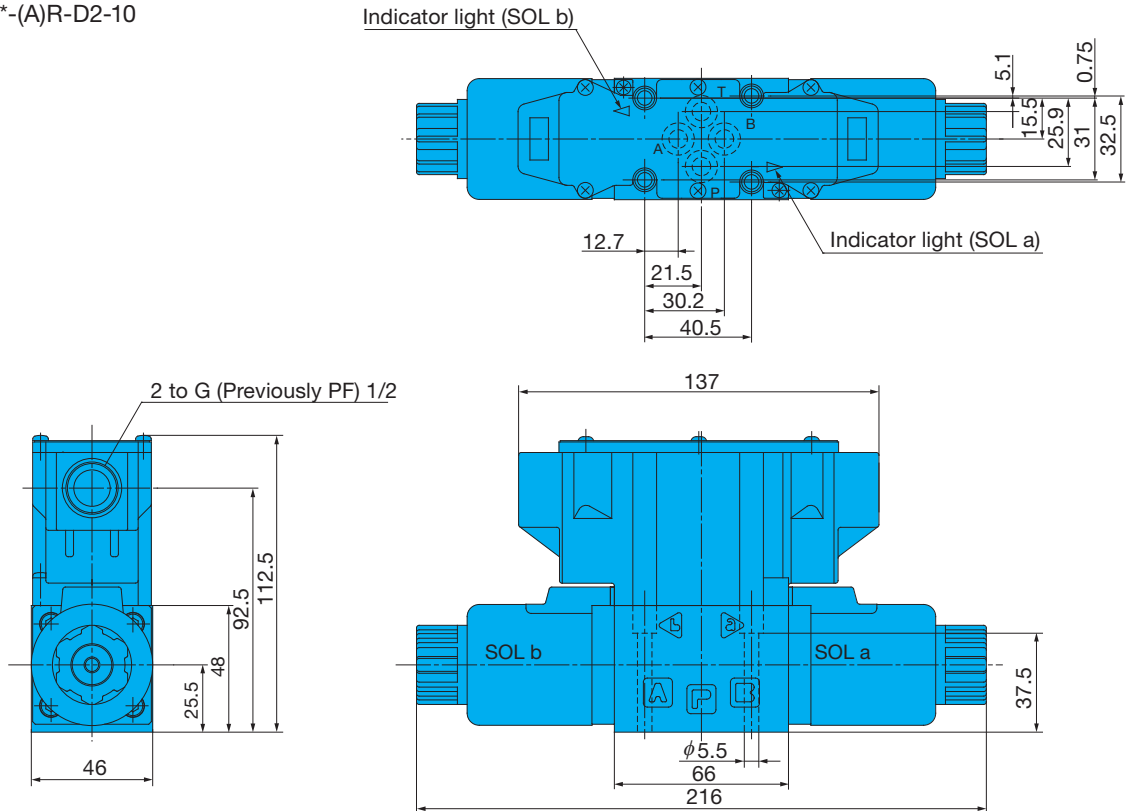

Performance Curves

Hydraulic Operating Fluid Kinematic Viscosity 32mm²/s

● Pressure – Flow Rate Characteristics

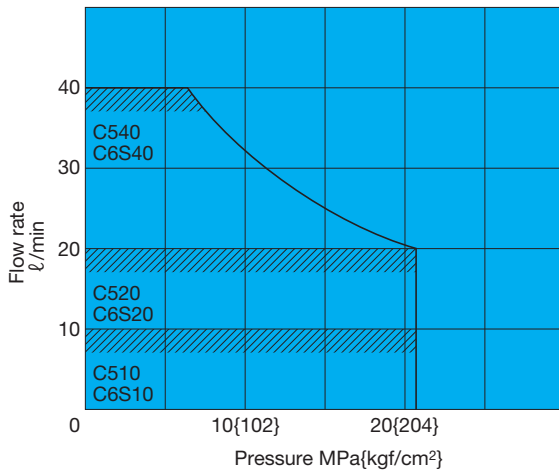

- Use the valve within the allowable flow rate range shown by the graph to the Left.
- There are no operational problems within the allowable flow rate range, even when one-pass is used.

● Control Waveform Example

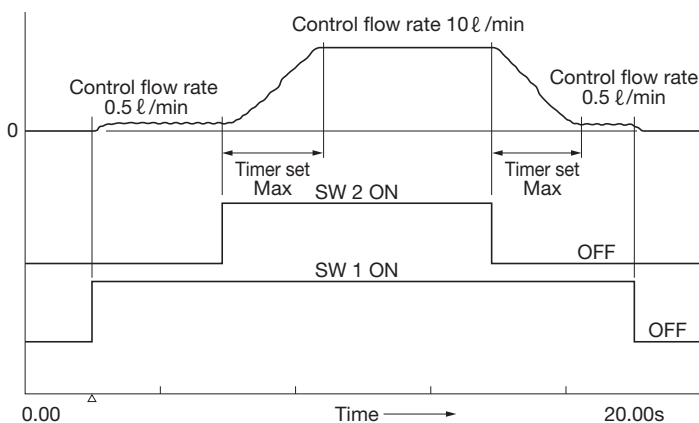

- Valve: SF-G01-C510-R-D2-10
- Supply Pressure: 21MPa{214kgf/cm²}
- Hydraulic Circuit

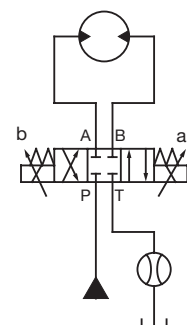

Cross-sectional Drawing

SF-G01-C***-(A)R-D2-10

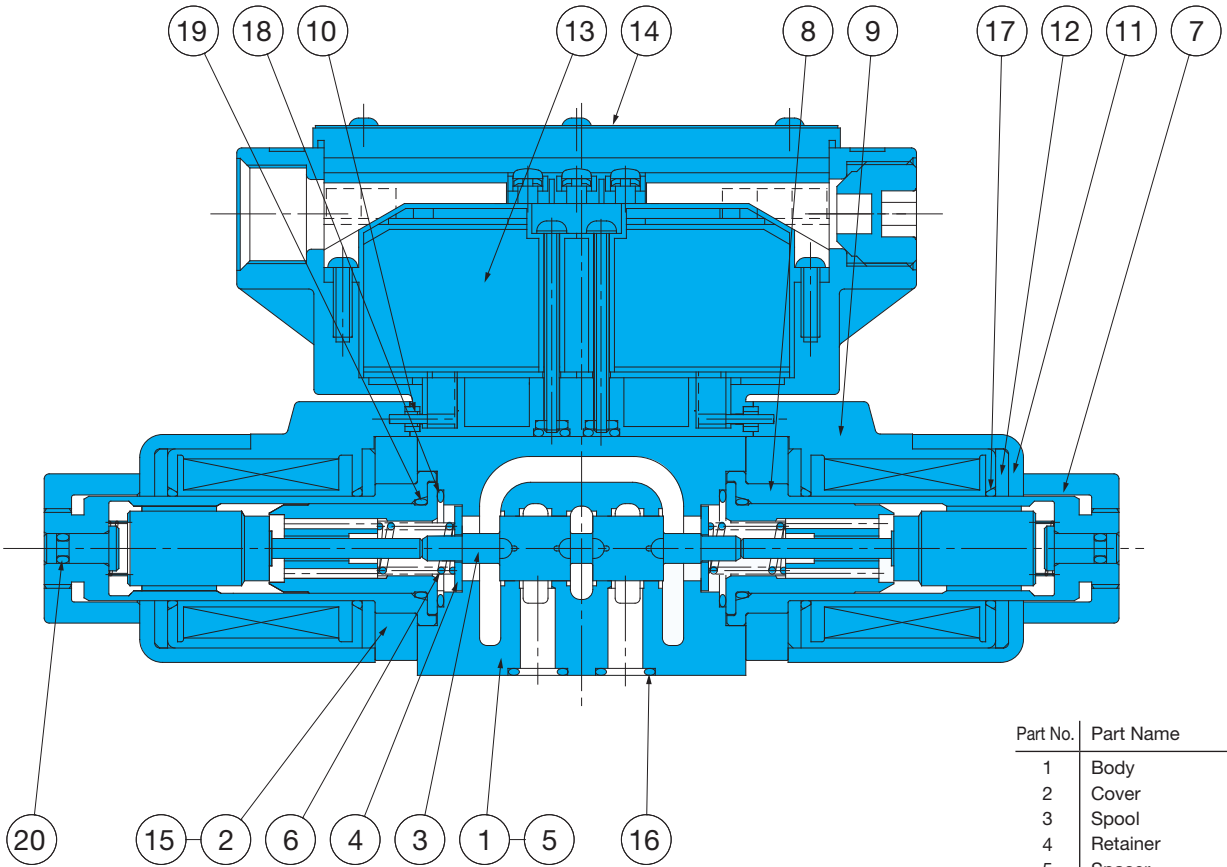

Part No.	Part Name
1	Body
2	Cover
3	Spool
4	Retainer
5	Spacer
6	Spring
7	Nut
8	Solenoid guide
9	Solenoid coil
10	Packing B
11	Coil case
12	Coil yoke
13	Central terminal box kit
14	Nameplate
15	Hexagon Socket Head Bolt
16	O-ring
17	O-ring
18	O-ring
19	O-ring
20	O-ring

Seal Part List (Kit Model Number EFS)

Part No.	Part Name	Type/Part Number	Q'ty
16	O-ring	AS568-012(NBR-90)	4
17	O-ring	AS568-019(NBR-70-1)	4
18	O-ring	AS568-019(NBR-90)	2
19	O-ring	AS568-017(NBR-90)	2
20	O-ring	P3 Note2	2

Note) 1. The materials and hardness of the O-ring conforms with JIS B2401.

2. Special flurorubber is used (Part Number: RO-P3-VS).

Solenoid Valve