

SCW Series

Poppet type directional control valve with monitoring switch

50ℓ/min
21MPa

Features

This valve is a poppet activated directional control valve that uses mechanical detection to operate a switch to send an electric ON/OFF signal. This makes it possible, by monitoring the status of the spool operations, to use it as an information source for safety checks by using the ON/OFF signal as a basis for sequence control. In the future, they will be used in machinery that is compatible with international machine safety (ISO 12100) and JIS standards (JIS B 9700)

standards.

The poppet type directional control valve with monitoring switch was developed as a valve to support this demand.

- ①The switch contact has little dead zone and almost no temperature drift (variable motion caused by changes in temperature) or hysteresis because the reaction of the poppet action is mechanical.
- ②All valve functions, except for the monitoring function, are equivalent to

the standard poppet type directional control valve.

- ③DIN connectors are used for the switches and solenoid coil wiring so connections are easy when installing or replacing valves.

Operational Principle

When the needle valve is in the center position, the fixed and moving parts are in contact forming an electric circuit. The solenoid turns on, the needle valve operates so there is no circuit between the fixed and moving parts.

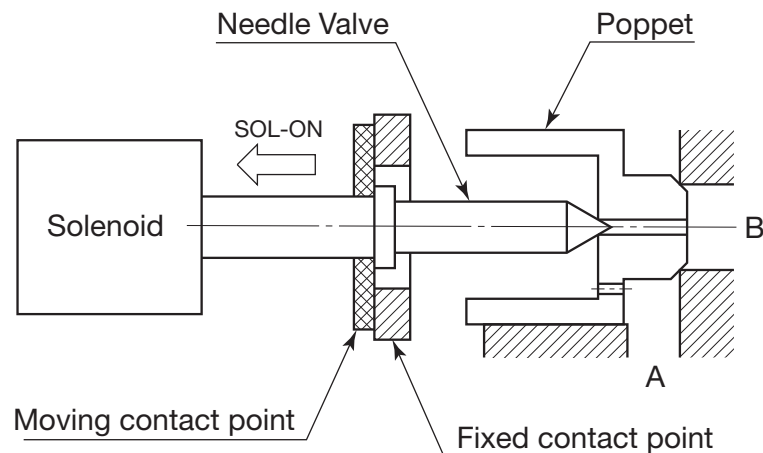

Specifications

●Valve Specifications

Operation Symbol		-AR-	-ARC-
JIS Symbol			
Maximum Working Pressure (A, B ports)		21MPa	
Maximum Flow Rate	A → B	50ℓ/min	50ℓ/min
	B → A	—	
Cracking Pressure of Check Valve		0.3MPa	
Switching Frequency		120/minute	
Weight		2.3kg	
Operating Environment	Dust Resistance/Water Resistance Rank	JIS C 0920 IP65	
	Operating Fluid	Oil-based operating fluid (Note 1)	
	Ambient Temperature Range	-20 to 50°C	
	Operating Oil Temperature Range	-20 to 70°C	
	Operating Kinematic Viscosity Range	15 to 300mm ² /s	
Mounting bolt (Note2)	Filtration	25μm or less	
	Size × Length	Socket hex head bolt (12.9 strength classification or equivalent) M6 × 55, 4 each	
	Tightening Torque	10 to 13N·m	

Note) 1. Use a petroleum based operating fluid because the ON/OFF mechanism of the valve's monitoring switch is immersed in oil and the oil must be a nonconducting fluid.

Use only petroleum based operating fluid (do not use fluids that are water, glycol, W/O emulsion, phosphate, or fatty ester based). Petroleum based operating fluids must also have a water content that is less than 0.1% by volume.

2. Installation bolts are provided with valves.

●Monitoring Switch Specifications

Voltage Rating	DC24V
Allowable Voltage Range	± 20% of voltage rating
Maximum Current Load	100mA
Residual Voltage (Note 3)	max. 1.2V
Wiring for Connector for Switch	Connect with wires or M12-4 pin connector

- Note) 1. See page E-78 for the procedure to wire the connector for the switch.
 2. The programmable controller input circuits are positive (+) common mode and negative (-) common mode.
 The directional control valve with monitoring switch uses a source circuit [switch on the positive (+) side of the load and power source] for safety purposes.
 Because of this, it is necessary to use a negative (-) common mode programmable controller to receive input from the monitoring switch output.
 3. Set the voltage of the power supply to the monitoring switch within a range that satisfies the following conditions.
 Load ON voltage + residual voltage ≤ switch supply voltage ≤ 28.8 V (+20% voltage rating)
 4. The switch element (photocoupler) in the connector's internal circuit for the monitoring switch may malfunction in the ON state because of over voltage or over current.
 Therefore, in addition to checking the ON output of the monitoring switch, monitor the current at the solenoid and the internal circuits of the connector and valve in conjunction with the switch output.

Condition of monitoring switch output and valve

		Current to Solenoid				
		ON	OFF			
Monitoring Switch Output	ON	Abnormal Malfunction at internal circuit of connector or valve	Normal Needle valve returns to middle position			
	OFF	Normal Needle valve is switching	<table border="1"> <tr> <td>Pressure from A port (Closed)</td> <td>Abnormal Valve malfunction or signal wire is cut</td> </tr> <tr> <td>Pressure from B port (Flows from B → A port)</td> <td>Normal Poppet opens and needle valve operates</td> </tr> </table>	Pressure from A port (Closed)	Abnormal Valve malfunction or signal wire is cut	Pressure from B port (Flows from B → A port)
Pressure from A port (Closed)	Abnormal Valve malfunction or signal wire is cut					
Pressure from B port (Flows from B → A port)	Normal Poppet opens and needle valve operates					

The monitoring switch outputs according to the motion of the spool, so the solenoid turns on and off according to the output signal which is delayed only as much as the spool operation is delayed.
 Set a 0.3 second delay, including leeway, to monitor the output of the switch.

●Solenoid Specifications

Same specifications as the SA-G01 series (31 design).

Solenoid Type	Power Supply Type	Voltage (V)	Frequency (Hz)	Solenoid Coil Type	Drive Current (A)	Holding Current (A)	Holding Power (W)	Allowable Voltage Range (V)
DC with Built-in Rectifier	E1	AC100	50/60	EAC64-E1-1A	0.31		27	90 to 110
	E115	AC110	50/60	EAC64-E115-1A	0.26		25	100 to 125
		AC115			0.27		27	
	E2	AC200	50/60	EAC64-E2-1A	0.15		26	180 to 220
	E230	AC220	50/60	EAC64-E230-1A	0.12		24	200 to 250
		AC230			0.13		27	
DC	D1	DC12	—	EAC64-D1-1A	2.2		26	10.8 to 13.2
	D2	DC24	—	EAC64-D2-1A	1.1		26	21.6 to 26.4

●Handling

- Do not allow abnormal surges greater than the maximum operating pressure to occur because pressure from the B port is used for the solenoid.
- Always keep the operating fluid clean. Allowable contamination is class NAS12 or less.
- Use a JIS K 2213 petroleum-based operating fluid, or an equivalent, that has a water content that is less than 0.1% by volume.
- Do not use fire-resistant operating fluid.
- Use this valve only within the allowable voltage range.
- The only way to prevent misoperation of the monitoring switch caused by noise generated by the solenoid turning on and off is to install the surgeless directional control valve with monitoring switch (option symbol: GR).

- (If the solenoid power source is C* and D*)
- Use surgeless specification (with varistor diode) directional control valves with monitoring switches for all electric valves on the same machine to prevent misoperation of the monitoring switch caused by noise when the solenoid turns on and off.
 - The coil surface temperature increases if this valve is kept continuously energized. Install the valve so there is no chance of it being touched directly by hand.

- The connector for the solenoid is the same as for the SA series solenoid valve. See page E-19 for electrical circuit drawings and wiring procedures.
- Use the following table for specification when a sub plate is required.

Model No.	Pipe Diameter	Maximum Working Pressure MPa(kgf/cm ²)	Recommended Flow Rate (ℓ/min)	Weight (kg)	Dimension Drawings Page
MSA-03-10	3/8	25(255)	45	2.3	E-18
MSA-03X-10	1/2		80		
MSA-03-T-10	3/8		45	3.8	D-90
MSA-03X-T-10	1/2		80		

Explanation of model No.

SCW - G 03 - ARC - GR V - D2 - J11

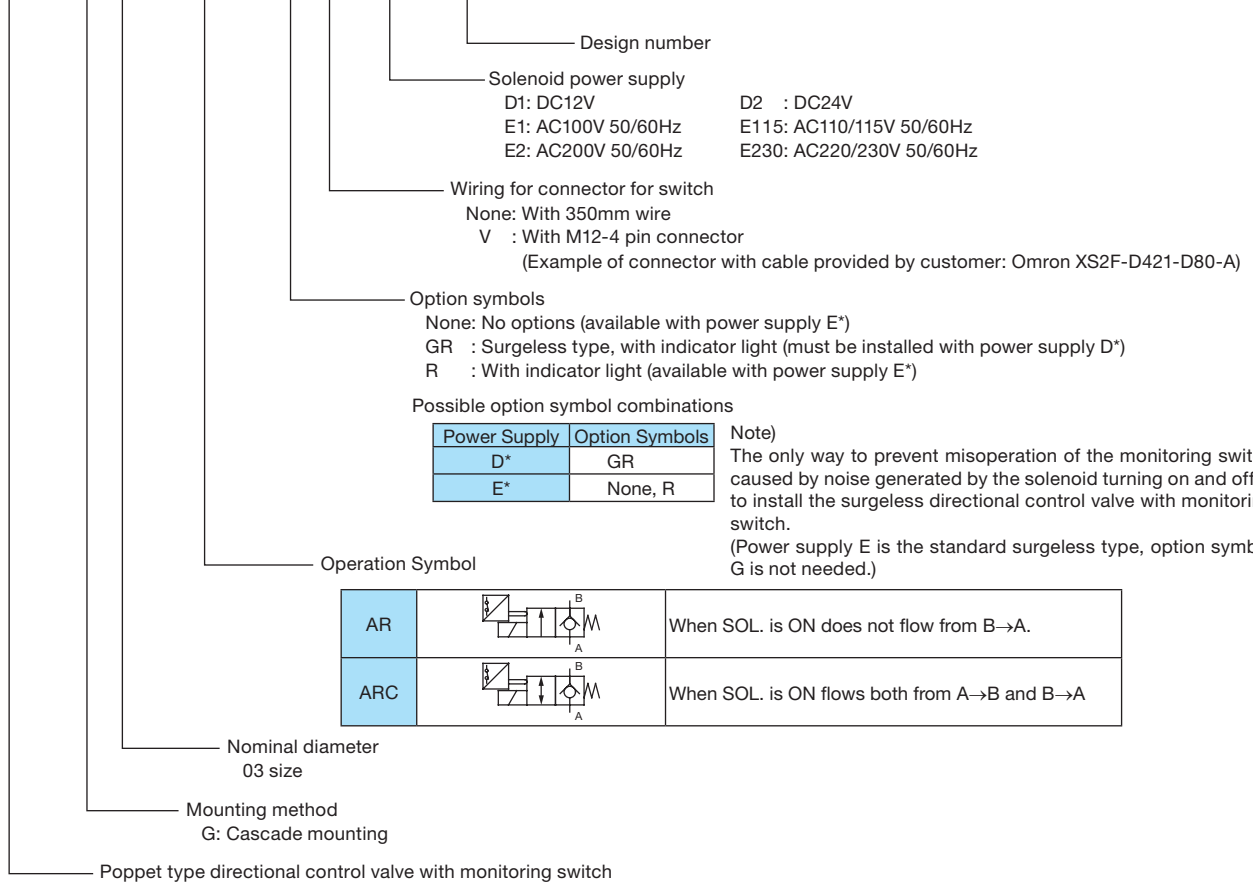

Installation Dimension Drawings

Dimensions of installation surface of gasket are ISO 4401-05-04-0-05.
 However, used only for port A and B.

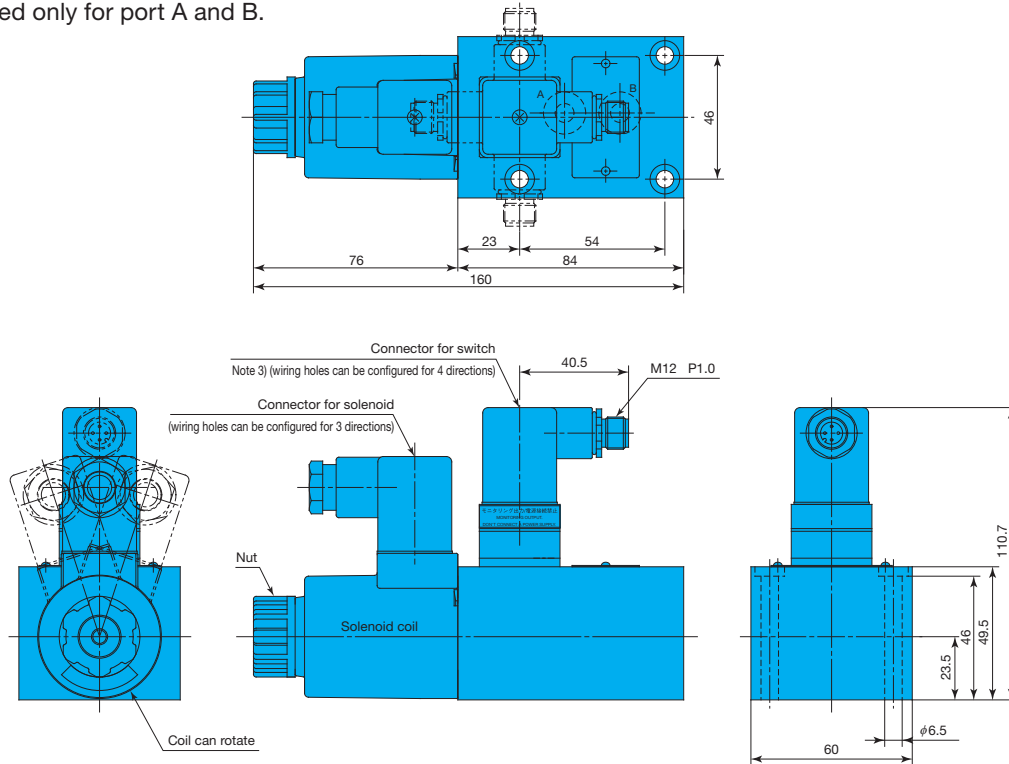

- Note) 1. The connector for the switch in the drawing above is the M12-4 pin connector. In addition there are wire connections also. See page E-78 for more detailed information.
2. Use surgeless directional control valves with monitoring switches for all electric valves on the same machine to prevent misoperation of the monitoring switch caused by noise when the solenoid turns on and off.
3. To orient the wiring hole for the connector for the switch towards the solenoid coil, loosen the nut and rotate the solenoid coil so the connector for the switch does not interfere with the connector for the solenoid.

●Details about the Connector for the Switch

(1) With wiring (option symbol: none)

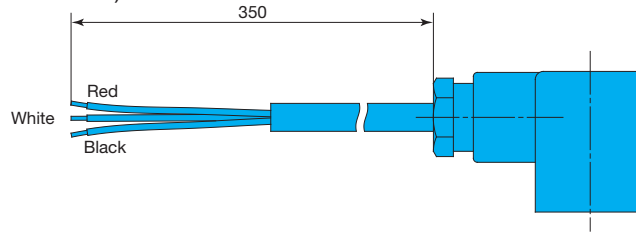

(2) With M12-4 pin connector (option symbol: V)

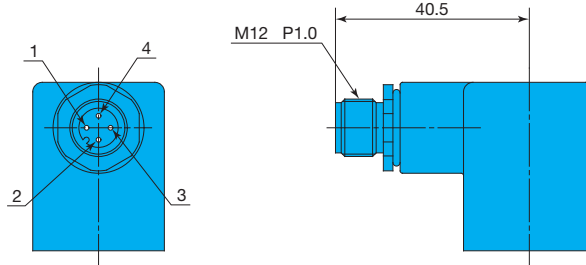

Note) 1. The pin connector is screwed to the housing so it is rotated a certain amount compared to the drawing. Refer to the electrical circuit diagram below for how to connect it.
 2. The connector that the M12-4 pin connector connects to is not provided.
 (Example of connector with cable provided by customer: Omron XS2F-D421-D80-A)

(3) Electrical circuit diagram

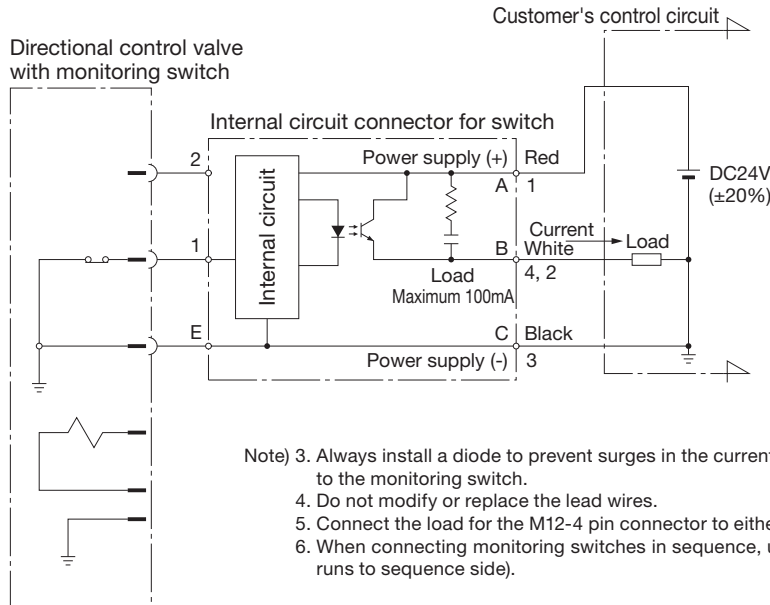

Method for Wiring to Connector with Switch

Wiring Method		Connection
Wire Color	Pin Number for M12-4 pin Connector	
Red	1	Power supply (+)
White	4 or 2	Load
Black	3	Power supply (-)

Note) 3. Always install a diode to prevent surges in the current when connecting an inductive load, such as a relay, to the monitoring switch.
 4. Do not modify or replace the lead wires.
 5. Connect the load for the M12-4 pin connector to either pin number 4 or 2.
 6. When connecting monitoring switches in sequence, use the negative (-) common mode (type that current runs to sequence side).

Performance Curves

Hydraulic Operating Fluid Kinematic Viscosity 32mm²/s

Pressure Loss Characteristics

Operation Symbol	JIS Symbol	SOL OFF B → A	SOL ON	
			A → B	B → A
AR		c	a	—
ARC		c	a	b

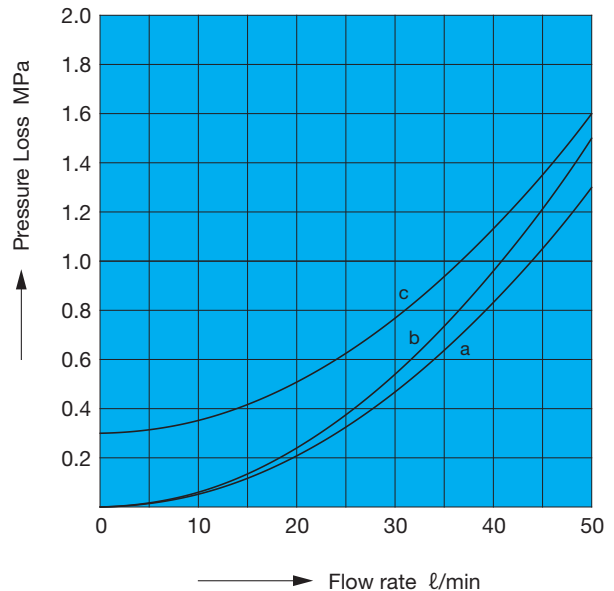

Range of Motion of Switch

Positions	Stroke of Poppet		
	SOL. ON	Switching Transition	Center
Flow Path			
Motion of Switch	OFF		ON

Note) 1. Internal leak exists at of switching transition period.

2. ON and OFF indicate the state of the output transistor on the circuit board in the connector.

Switching Responsiveness

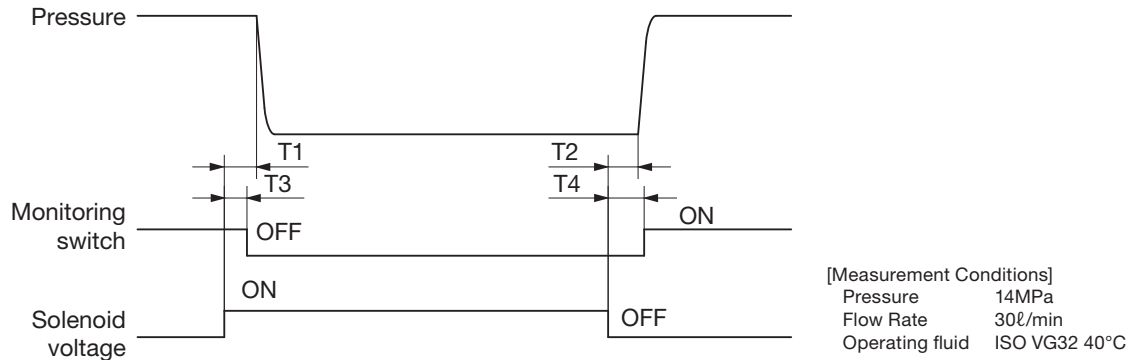

Type of Machine	Model	Response Time (s)			
		Pressure		Switch	
		T1	T2	T3	T4
DC Solenoid	SCW-G03-AR-GR-D2-J11	0.03 to 0.04	0.02 to 0.03	0.01 to T1	T2 to 0.05
DC Solenoid with Built-in Rectifier	SCW-G03-AR-E1-J11	0.03 to 0.04	0.08 to 0.11	0.01 to T1	T2 to 0.20

Note) May vary depending on switching response time and operating conditions (pressure, flow rate, and oil temperature).

Cross-sectional Drawing

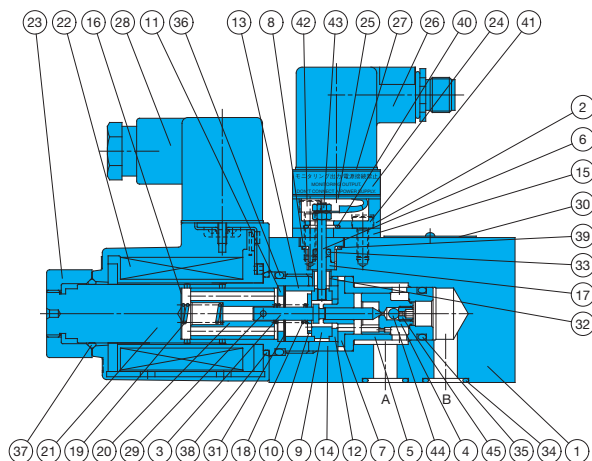

Part No.	Part Name	Part No.	Part Name	Part No.	Part Name
1	Body	16	Spacer (sealing prevention)	31	Wave washer
2	Cover (connector)	17	Collar (insulated)	32	Spacer (ring rotation prevention)
3	Needle Valve	18	Spring (contact side)	33	O-ring *
4	Poppet	19	Spring (guide side)	34	O-ring *
5	Sleeve	20	Solenoid plunger	35	O-ring *
6	Rod (conductor)	21	Solenoid guide	36	O-ring *
7	Bush (needle valve support)	22	Solenoid coil	37	O-ring *
8	Bush (insulated)	23	Nut	38	O-ring *
9	Retainer (fixed contact)	24	Connector with lead wire	39	O-ring *
10	Retainer (movable contact)	25	Packing	40	O-ring *
11	Retainer (flange side)	26	Connector with built-in photo-coupler	41	Hexagon socket head bolt
12	Ring (insulation inside)	27	Connector packing	42	Hexagon socket head bolt
13	Ring (insulation outside)	28	Connector	43	Hexagon nut
14	Ring (fixed by sleeve)	29	Parallel pin	44	Steel ball ★
15	Plate (connector)	30	Nameplate	45	Set screw ★

Seal Part List (Kit Model Number EQS-SC)

Part No.	Part Name	Part Number	Q'ty
33	O-ring	NBR-90 P3	1
34	O-ring	AS568-014(NBR-90)	2
35	O-ring	NBR-90 P14	1
36	O-ring	AS568-119(NBR-90)	1
37	O-ring	NBR-70-1 P20	1
38	O-ring	S-25(NBR-70-1)	1
39	O-ring	S-11.2(NBR-90)	1
40	O-ring	S-9(NBR-70-1)	1

Note) 1. For details about parts marked with an asterisk ***, refer to the list of seals in the table on the right.

2. Products marked with a ★ use only SCW-G03-ARC-**-**-J11 and do not use SCWG03-AR-**-**-J11.

Note) NBR are JIS Standard B 2401, while AS568 is SAE standard.