

Relief Valve

20 to 380ℓ/min
21MPa

Features

- ① Balanced piston relief valve.
- ② Optimum pressure control for hydraulic circuit allows operation as a safety valve.
- ③ A vent port enables remote control of pressure and use of an unloading circuit.

Specifications

Model No.		Nominal Diameter (Size)	Maximum Working Pressure MPa(kgf/cm ²)	Maximum Flow Rate ℓ/min	Pressure adjustment range MPa(kgf/cm ²)	Weight kg	
Screw Mounting	Gasket Mounting					T Type	G Type
R-T03-A-12 B-12	R-G03-A-12 B-12	3/8	21 {214} P, X (Vent Ports)	20	* to 1 { * to 10.2 } * to 2.5 { * to 25.5 }	3.0	4.3
R-T03-1-12 3-12	R-G03-1-12 3-12	3/8		80	* to 7 { * to 71.4 } 3.5 to 21 {35.7 to 214 }	3.0	4.3
R-T06-1-20 3-20	R-G06-1-20 3-20	3/4		170	* to 7 { * to 71.4 } 3.5 to 21 {35.7 to 214 }	3.9	5.3
R-T10-1-20 3-20	R-G10-1-20 3-20	1¼		380	* to 7 { * to 71.4 } 3.5 to 21 {35.7 to 214 }	7.7	7.7

Note) See the Flow Rate - Low Pressure characteristics for information about items marked with an asterisk (*).

● Handling

- ① To adjust pressure, loosen the lock nut and then rotate the handle clockwise (rightward) to increase pressure or counterclockwise (leftward) to decrease it.
- ② Make sure that tank port back pressure is no greater than 0.2MPa {2.0kgf/cm²}. For tank piping of the A and B type pressure adjusting ranges, return directly to the tank without connecting any other piping and eliminate back pressure.
- ③ The pressure adjustment range for the high vent type is 1.3MPa {13.3kgf/cm²}. Note that R-T/G03 is not a high vent type.
- ④ When using a relief valve as a safety valve, use a pressure override that is higher than the required circuit pressure.
- ⑤ When using a remote control valve, connect piping to the relief valve port. Pipe capacity can be a source of vibration. Use of thick iron pipe with an inside diameter of no more than 4mm and a connection length of no more than three meters is recommended.
- ⑥ Pressure becomes unstable when at slow control flow rates. Use a flow rate of no less than 8 ℓ/min for the 03, 06 sizes, and 10 ℓ/min for the 10 size. Use a drain type relief valve in the case of a flow rate that is less than the minimum flow rate.

⑦ Use the following table for specification when a sub plate is required.

Model No.	Pipe Diameter	Weight kg	Applicable Pump Model
MR-03-10	3/8	1.6	R-G03-*-12
MR-06-20	3/4	3.5	R-G06-*-20
MR-06X-20	1		
MR-10-20	1¼	8.5	R-G10-*-20
MR-10X-20	1½		

⑧ The following are the bundled mounting bolts.

Model No.	Bolt Dimensions	Q'ty	Tightening Torque N·m(kgf·cm)
R-G03-*-12	M10×75ℓ	4	45 to 55 {460 to 560}
R-G06-*-20	M16×80ℓ	4	190 to 235 {1940 to 2400}
R-G10-*-20	M20×105ℓ	4	370 to 460 {3770 to 4690}

Note) For mounting bolts, use bolts of 12.9 strength classification or equivalent.

Explanation of model No.

R - T 06 - 1 - (H) - 20

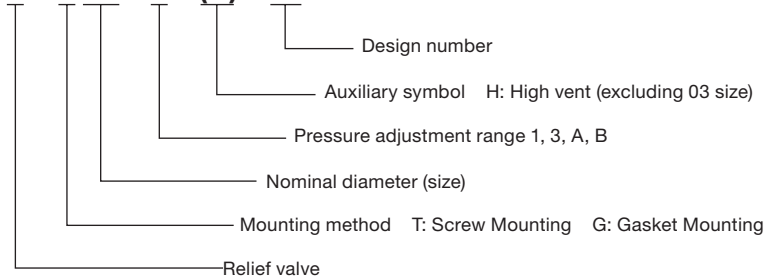

Installation Dimension Drawings

R-T03-*-12 (Screw Mounting)

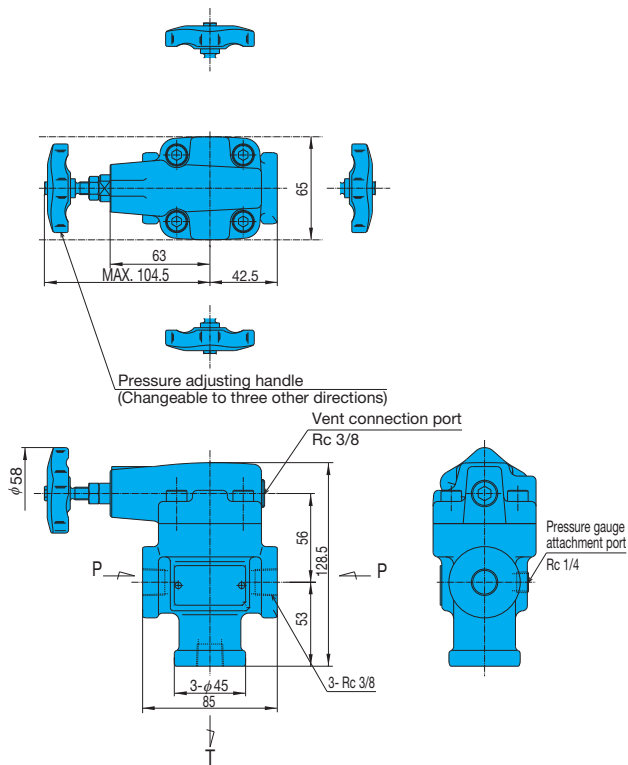

R-G03-*-12 (Gasket Mounting)

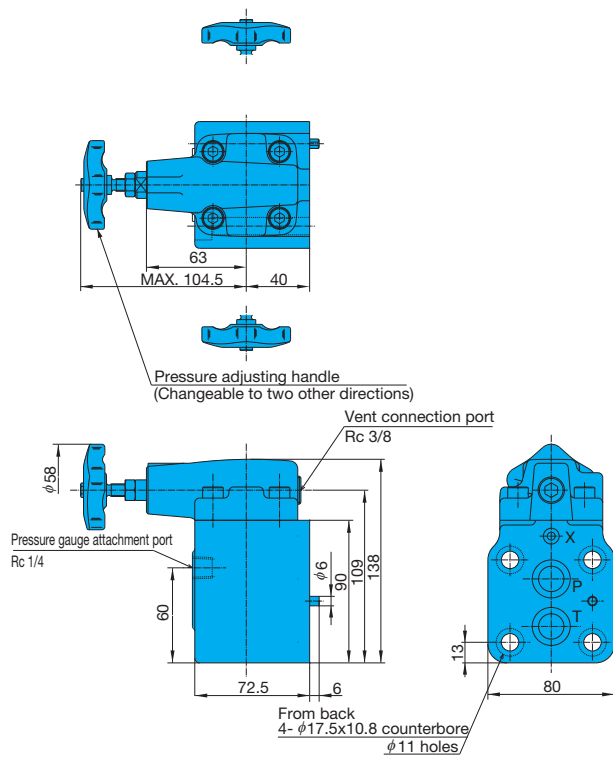

R-T**-*-20 (Screw Mounting)

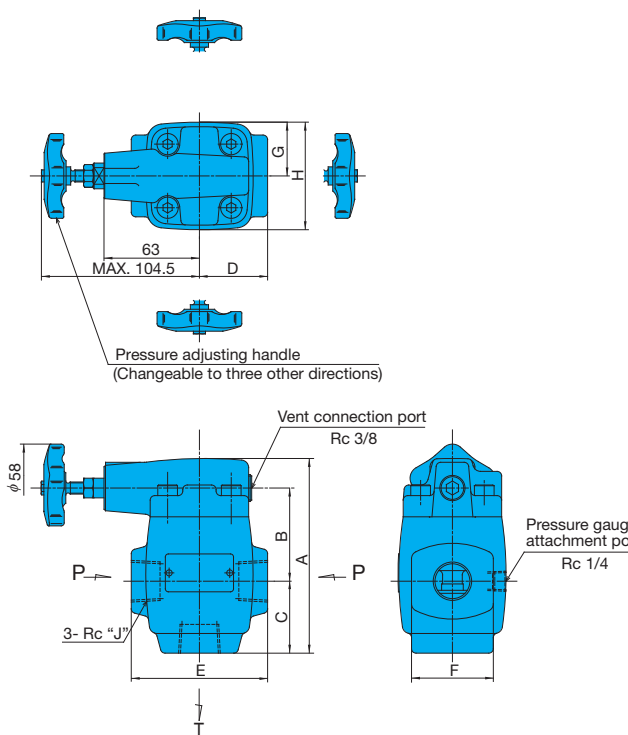

R-G**-*-20 (Gasket Mounting)

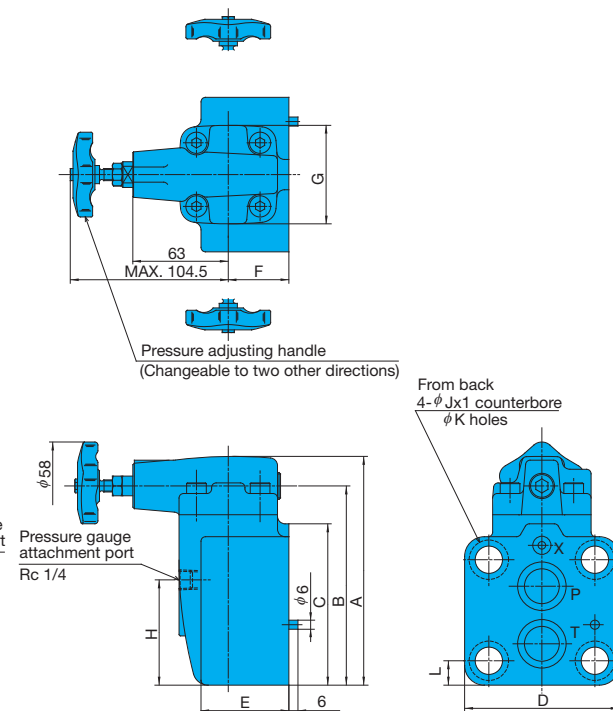

Model No.	A	B	C	D	E	F	G	H	J
R-T06-*-20	128.5	61.5	47.5	45	90	54	35.5	71	3/4
R-T10-*-20	153.5	72	62	62.5	125	69	47	94	1 1/4

Model No.	A	B	C	D	E	F	G	H	J	K	L
R-G06-*-20	151	131.5	106.5	102	58	40	65	69.5	26	18	16.1
R-G10-*-20	162.5	143	110	127	80	50	86	70.5	32	22	17.7

Sub Plate MR-03-10

MR-**-20

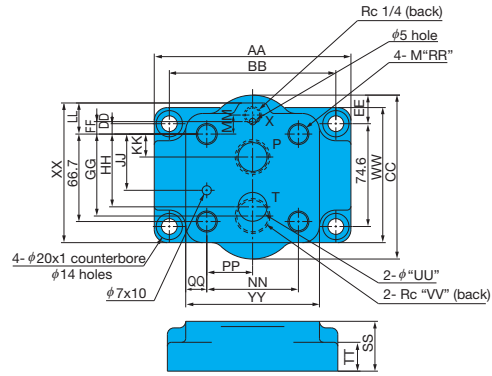
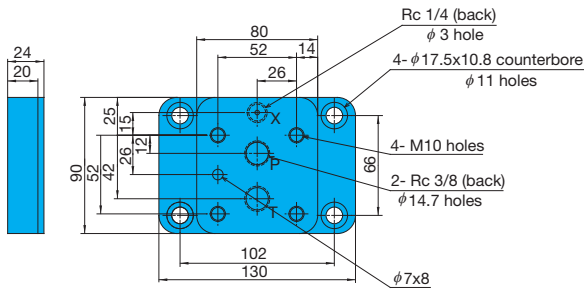

Model No.	Dimensions (mm)																						
	AA	BB	CC	DD	EE	FF	GG	HH	JJ	KK	LL	MM	NN	PP	QQ	RR	SS	TT	UU	VV	WW	XX	YY
MR-06-20	150	127	125	7.9	21.8	9.5	62.5	55.5	42.9	17.5	23.7	14.5	69.9	34.9	16.1	16	38	22	22	3/4	98.5	106.5	102
MR-06X-20																			1				
MR-10-20	175	152.4	150	6.4	39.2	15.9	71.3	58.7	50.8	14.3	25.6	25.9	92.1	46.1	17.5	20	55	22	28.5	1 1/4	102.5	110	127
MR-10X-20																			1 1/2				

Performance Curves

Hydraulic Operating Fluid Kinematic Viscosity 32mm²/s

Pressure - Flow Rate Characteristics

R-*03-**-12

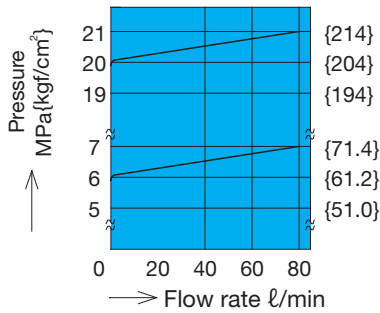

R-*06-**-20

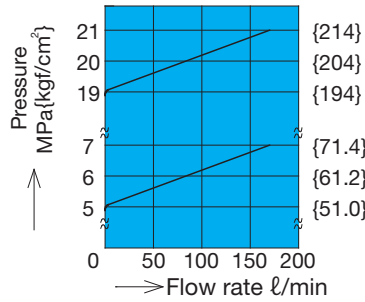

R-*10-**-20

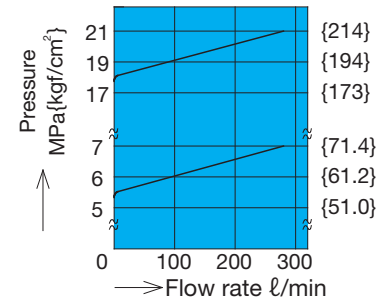

Flow Rate - Minimum Pressure Characteristics

R-*03-^A/_B-12

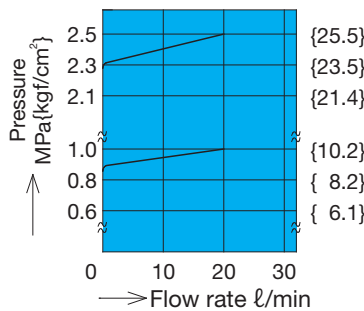

R-*03-^A/_B-12

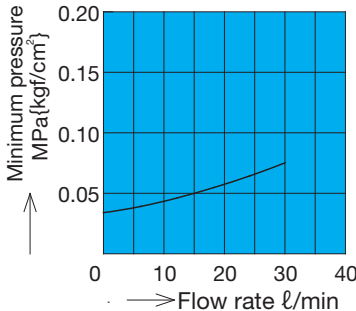

R-*03-1-12

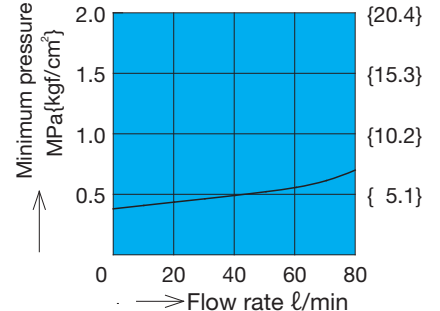

R-*06-1-20

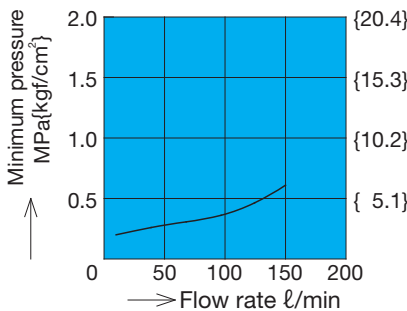

R-*10-1-20

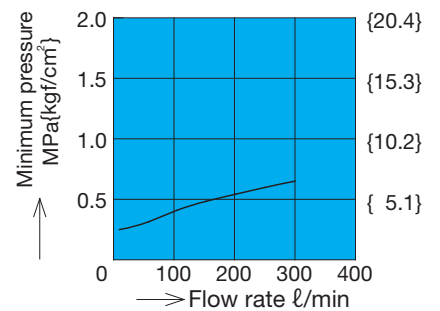

Note) The performance curves do not include T port back pressure.

Cross-sectional Drawings

R-G03-^A/_B-12

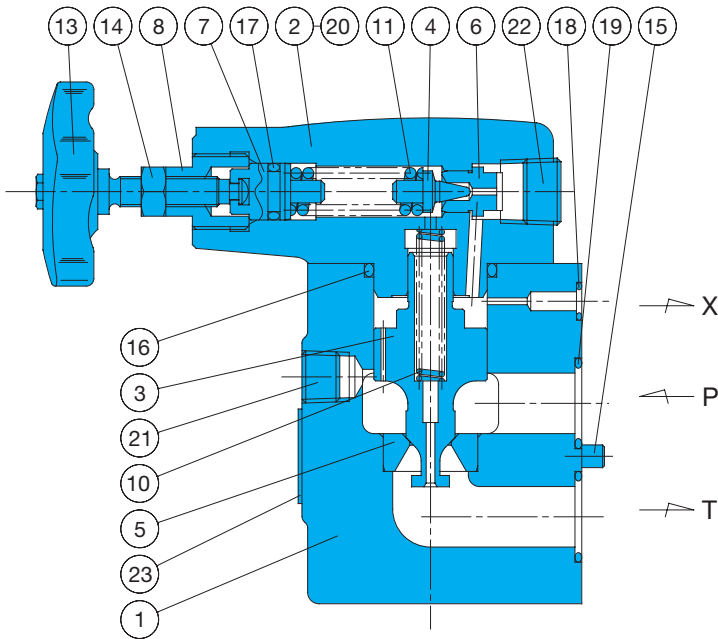

R-G03-¹/₃-12

R-G^{06.1}/_{10.3}-20

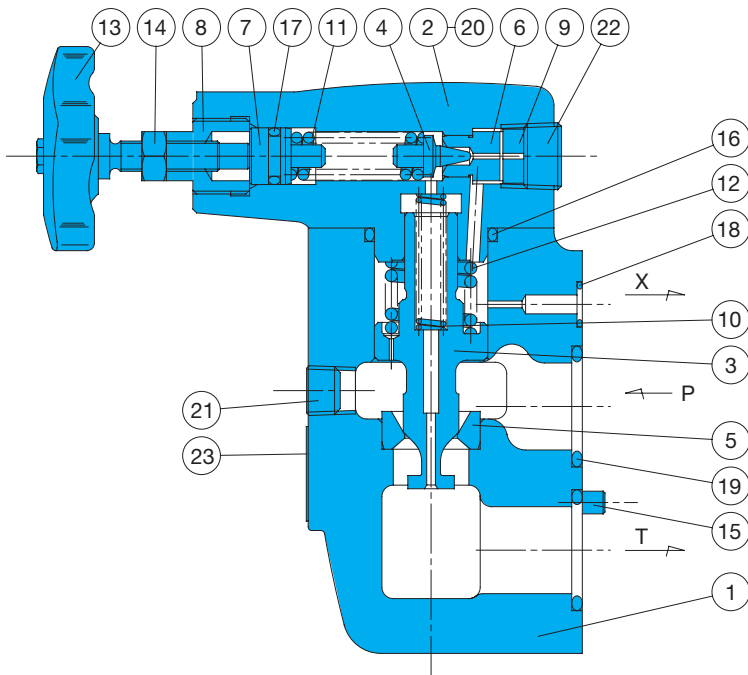

Part No.	Part Name
1	Body
2	Cover
3	Spool
4	Poppet
5	Seat
6	Seat
7	Plunger
8	Retainer
9	Collar
10	Spring
11	Spring
12	Spring
13	Handle
14	Nut
15	Spring pin
16	O-ring
17	O-ring
18	O-ring
19	O-ring
20	Screw
21	Plug
22	Plug
23	Nameplate

Note) The No. 12 spring is not included when auxiliary symbol H is selected (except with the 03 size).

Seal Part List (Kit Model Number RRS-*** (03 size)
RRBS-*** (06, 10 size))

Part No.	Part Name	Type/Part Number						Q'ty
		R-G03-* -12	R-T03-* -12	R-G06-* -20	R-T06-* -20	R-G10-* -20	R-T10-* -20	
16	O-ring	NBR-90 G30	NBR-90 G30	NBR-90 G30	NBR-90 G30	NBR-90 G40	NBR-90 G40	1
17	O-ring	NBR-70-1 P11	NBR-70-1 P11	NBR-70-1 P11	NBR-70-1 P11	NBR-70-1 P11	NBR-70-1 P11	1
18	O-ring	NBR-90 P7	-	NBR-90 P9	-	NBR-90 P9	-	1
19	O-ring	NBR-90 P20	-	NBR-90 P26	-	NBR-90 G35	-	2

Note) The materials and hardness of the O-ring conforms with JIS B2401.
*** in the kit number is used for specification of the valve size (G03, T06, etc.)