



Pressure Control (and Check) Valve

50 to 280ℓ/min
14MPa

Features

- ① This circuit control valve works as a sequence valve, unloading valve, and counter balance valve.
- ② Maximum operating pressure is 21MPa {214kgf/cm²}.
- ③ Though a direct type valve, there is little pressure override.
- ④ The mounting surface of the gasket conforms to the ISO standards shown in the table below.

Specifications

Model No.		Nominal Diameter (Size)	Maximum Working Pressure MPa(kgf/cm ²)	Maximum Flow Rate ℓ/min	Pressure adjustment range MPa(kgf/cm ²)	Weight kg		Gasket Surface Dimensions
Screw Mounting	Gasket Mounting					T Type	G Type	
(C) Q-T03-*A-21 B C D E	(C) Q-G03-*A-21 B C D E	3/8	21 {214} IN, OUT, PP Ports	50	Type A 0.25 to 0.85 {2.6 to 8.7} Type B 0.5 to 1.75 {5.1 to 17.9}	2.9 (3.1)	3.5 (3.8)	ISO 5781-06-07-0-00
(C) Q-T06-*A-21 B C D E	(C) Q-G06-*A-21 B C D E	3/4		120	Type C 0.85 to 3.5 {8.7 to 35.7}	5.0 (5.4)	6.0 (6.5)	ISO 5781-08-10-0-00
(C) Q-T10-*A-21 B C D E	(C) Q-G10-*A-21 B C D E	1 1/4		280	Type D 1.75 to 7 {17.9 to 71.4} Type E 3.5 to 14 {35.7 to 143}	9.8 (11.1)	11.5 (12.8)	ISO 5781-10-13-0-00

Weight values in parentheses are for when a check valve is included. The cracking pressure of the check valve is 0.1MPa {1.0kgf/cm²}.

Example circuit 1
When using type 2.

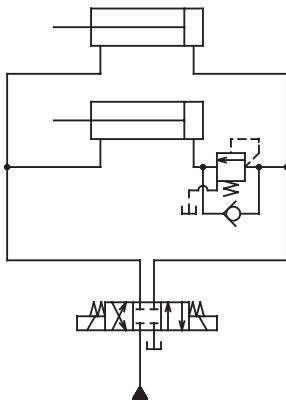

Example circuit 2
When using type 3.

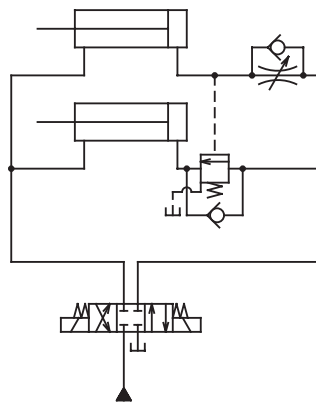

Explanation of model No.

(C)Q - G 10 - 1 B - 21

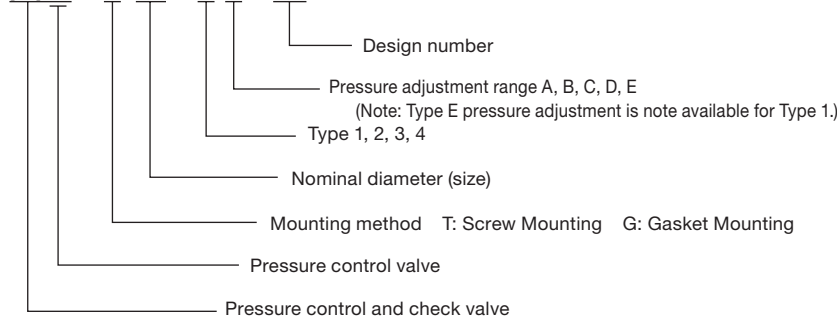

● Handling

- ① To adjust pressure, loosen the lock nut and then rotate the adjusting bolt clockwise (rightward) to increase pressure or counterclockwise (leftward) to decrease it.
- ② The pressure adjustment range is expressed in terms of cracking pressure.
- ③ Run the out port of Q-T/G** type 1 and 4 directly to the tank.
- ④ The following describes the method for using Types 2 and 3. Application of back pressure to the valve output side such as in the example circuit shown below, use Type 2 or Type 3 and run the drain port directly to the tank.
- ⑤ When two or more of these valves are ganged in sequence, make sure the setting pressure (cracking pressure) differential between them is at least 1MPa {10.2kgf/cm²}.
- ⑥ Vibration (chattering) may occur with the (C) Q-***-1E-21 depending on operating conditions when using type 1 and pressure adjustment range E. Use external drain type 2E if it happens.
- ⑦ Type 2 is standard. When Type 1, 3, or 4 is required, make modifications in accordance with the figures on the next page. Modifications change the valve type, so be sure to change the markings on the nameplate.
- ⑧ Use the following table for specification when a sub plate is required.

Model No.	Pipe Diameter	Weight kg	Applicable Pump Model
MG-03-20	3/8	1.6	(C) Q-G03-**-21
MG-03X-20	1/2		
MG-06-20	3/4	3.9	(C) Q-G06-**-21
MG-06X-20	1		
MG-10-20	1 1/4	6.7	(C) Q-G10-**-21
MG-10X-20	1 1/2		

Note) These sub plates can also be used for reducing valves.

- ⑨ The following are the bundled mounting bolts.

Model No.	Bolt Dimensions	Q'ty	Tightening Torque N·m(kgf·cm)
(C) Q-G03-**-21	M10×75	4	45 to 55 {460 to 560}
(C) Q-G06-**-21	M10×85	4	
(C) Q-G10-**-21	M10×105	6	

Note) For mounting bolts, use bolts of 12.9 strength classification or equivalent.

JIS Symbol

Q-***-**-21

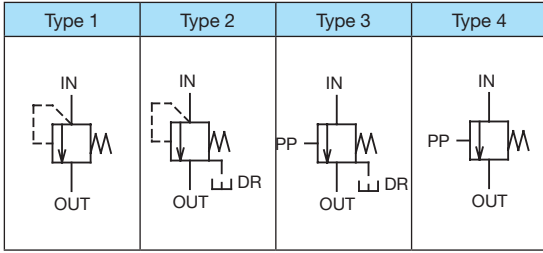

Type 2 is standard.

CQ-***-**-21

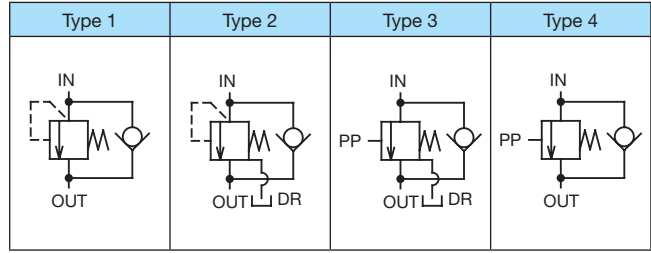

Installation Dimension Drawings

Q-T**-2*-21(Screw Mounting)

Type 1

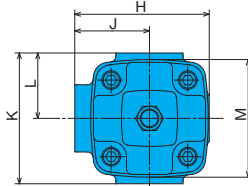
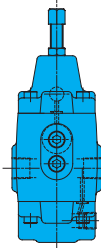

Type 3

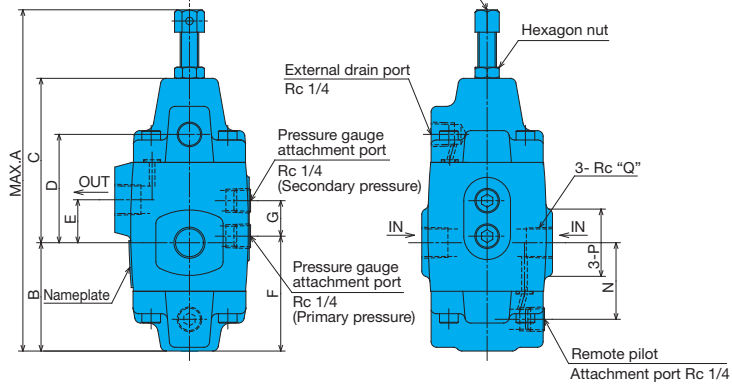
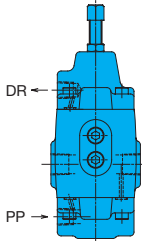

Type 4

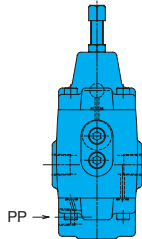

Model No.	A	B	C	D	E	F	G	H	J	K	L	M	N	P	Q
(C) Q-T03**-21	179.5	58	88	58	23	61.5	19	72	40	70	35	63	41	36	3/8
(C) Q-T06**-21	204.5	69.5	101.5	71.5	27	85	24	87	50	95	47.5	73	52.5	54	3/4
(C) Q-T10**-21	251	83.5	132.5	87.5	28	89	30	116	68.5	108	54	95	62.5	69	1 1/4

Q-G**-2*-21 (Gasket Mounting)

Type 1

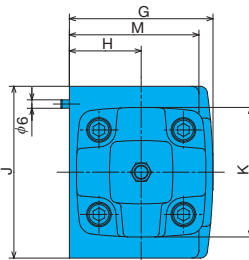
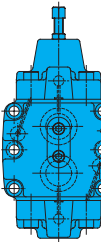

Type 3

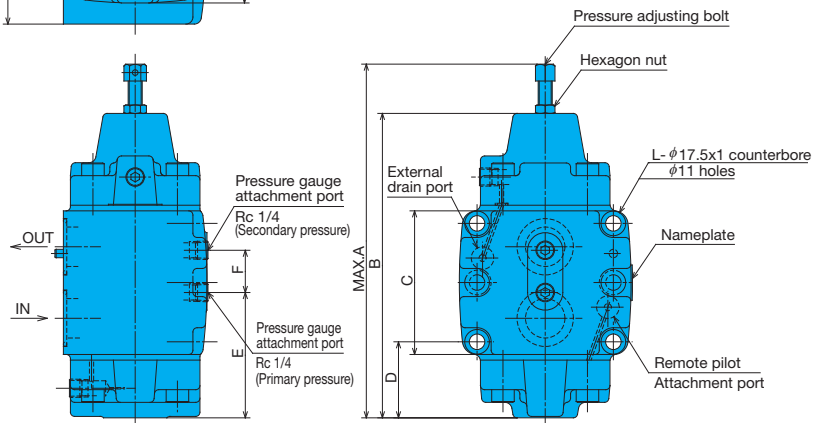
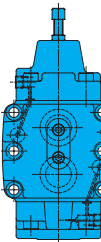

Type 4

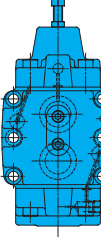

Model No.	A	B	C	D	E	F	G	H	J	K	L	M
Q-G03**-21	179.5	146	62	45.1	61.5	19	72	35	88	60	4	60
Q-G06**-21	204.5	171	82	51.4	75	24	80	40	102	70	4	70
Q-G10**-21	251	216	102	54	89	30	102	51	122	92	6	92



Pressure Control Valve

Installation Dimension Drawings

Type 1

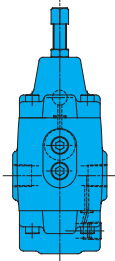

CQ-T**^{-2*}-21 (Screw Mounting)

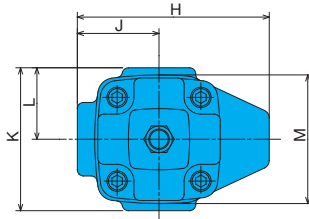

Type 3

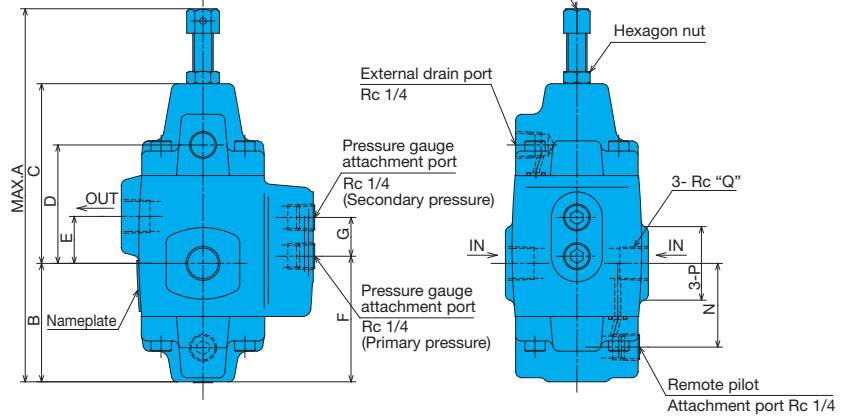
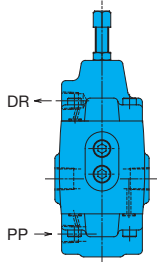

Type 4

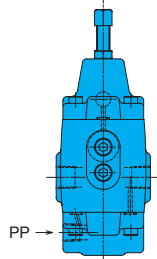

Model No.	A	B	C	D	E	F	G	H	J	K	L	M	N	P	Q
CQ-T03 ^{-**} -21	179.5	58	88	58	23	61.5	19	94	40	70	35	63	41	36	3/8
CQ-T06 ^{-**} -21	204.5	69.5	101.5	81.5	27	75	24	110	50	95	47.5	73	52.5	54	3/4
CQ-T10 ^{-**} -21	251	83.5	132.5	87.5	28	89	30	148.5	68.5	108	54	95	62.5	69	1 1/4

Type 1

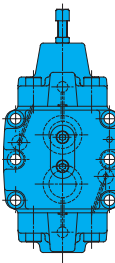

CQ-G**^{-2*}-21 (Gasket Mounting)

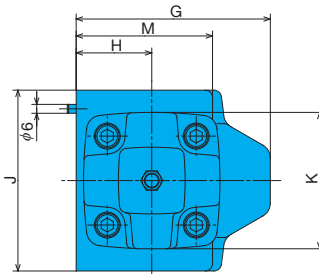

Type 3

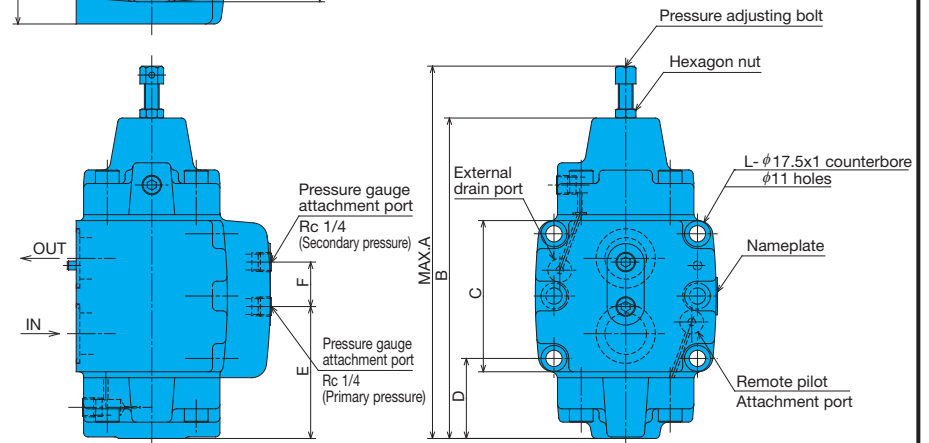
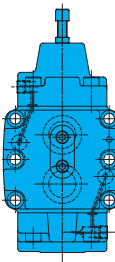

Type 4

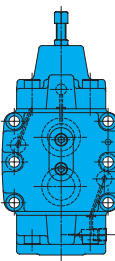

Model No.	A	B	C	D	E	F	G	H	J	K	L	M
CQ-G03 ^{-**} -21	179.5	146	62	45.1	61.5	19	89	35	88	60	4	60
CQ-G06 ^{-**} -21	204.5	171	82	51.4	75	24	100	40	102	70	4	70
CQ-G10 ^{-**} -21	251	216	102	54	89	30	131	51	122	92	6	92



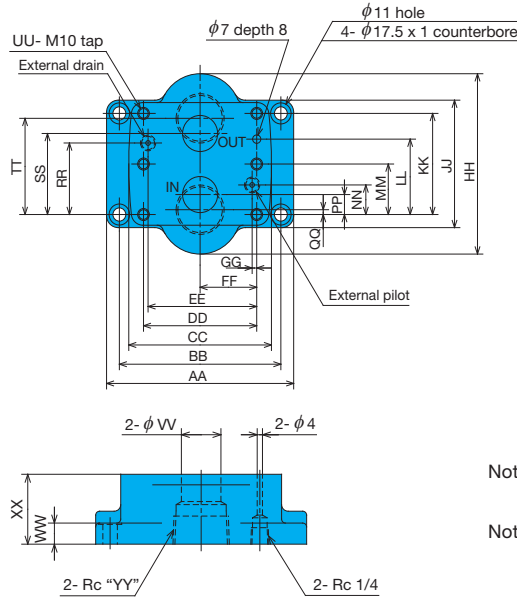

Note1) The figure shows size 10(X), with four M10 tap holes for size 03(X) and 06(X) valve mounting bolts.
 Note2) When a valve cover external drain and external pilot port are used, remove the plugs from the sub plate external drain and external pilot port.

Model No.	AA	BB	CC	DD	EE	FF	GG	HH	JJ	KK	LL	MM	NN	PP	QQ	RR	SS	TT	UU	VV	WW	XX	YY
MG-03-20	128	106.4	88	66.6	58.7	33.3	7.9	76	62	42.9	31.8	-	21.4	7.2	3.5	21.4	35.7	39.5	4	14	11	30	3/8
MG-03X-20																							1/2
MG-06-20	160	123.8	102	79.3	72.9	39.7	6.4	110	82	60.3	44.5	-	20.6	11.1	3.7	39.7	49.2	56.7	4	22	16	40	3/4
MG-06X-20																							1
MG-10-20	160	138.1	122	96.8	92.9	48.4	3.9	150	102	84.1	62.7	42.1	24.6	16.7	4.1	59.5	67.5	80.1	6	30	16	53	1 1/4
MG-10X-20																							1 1/2

Performance Curves

Hydraulic Operating Fluid Kinematic Viscosity 32mm²/s

Pressure Loss Characteristics

(C) Q-T03-**-21

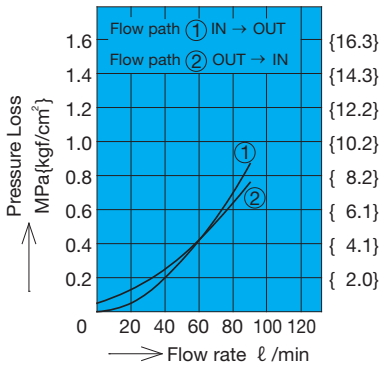

(C) Q-T06-**-21

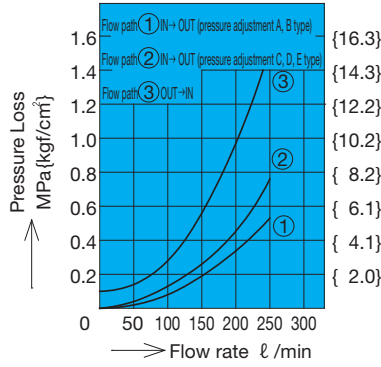

(C) Q-T10-**-21

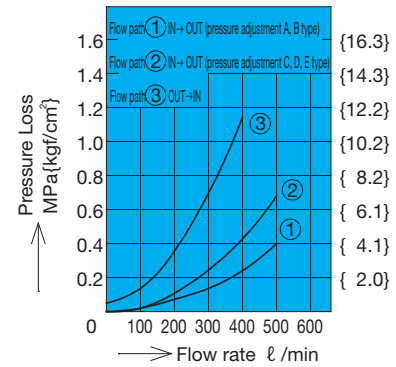

(C) Q-G03-**-21

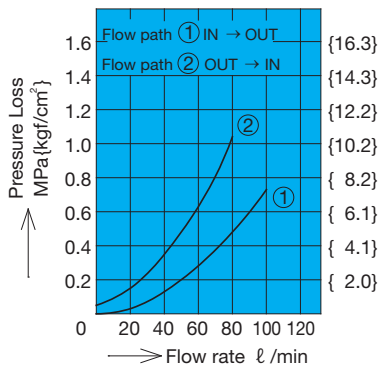

(C) Q-G06-**-21

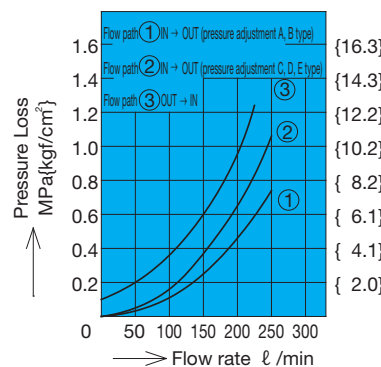

(C) Q-G10-**-21

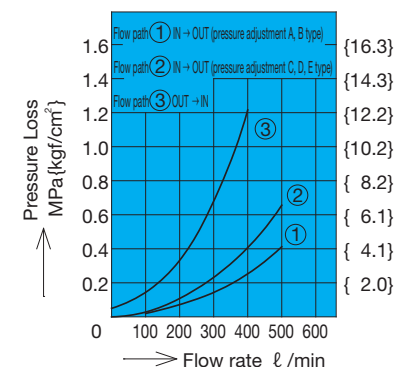

Pressure – Flow Rate Characteristics (— : Press rise
 (- - - : Pressure drop)

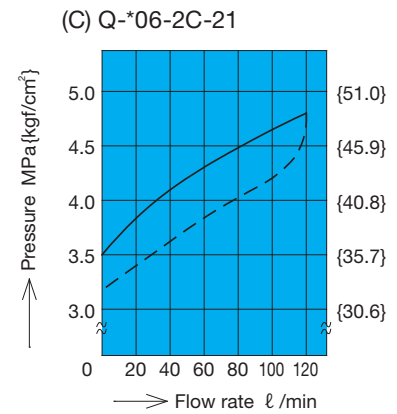
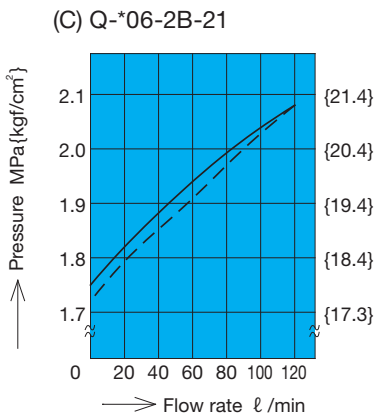
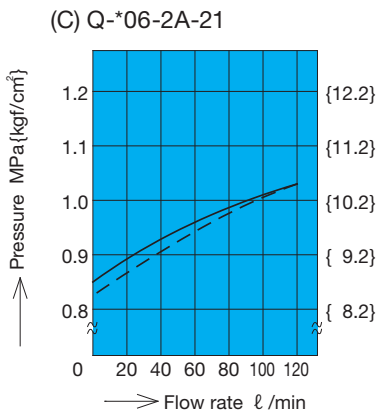
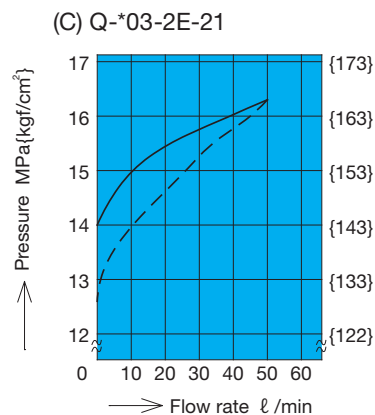
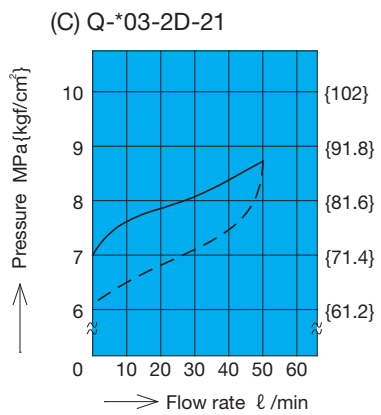
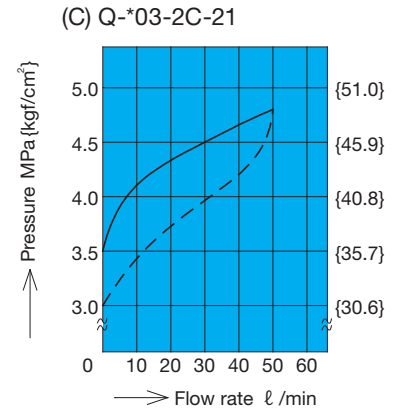
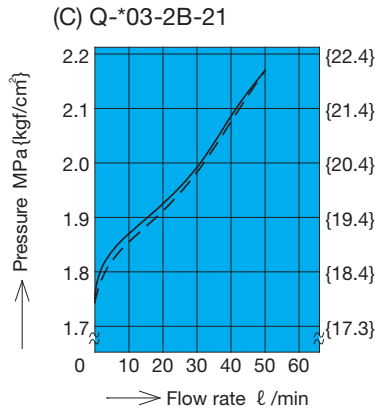
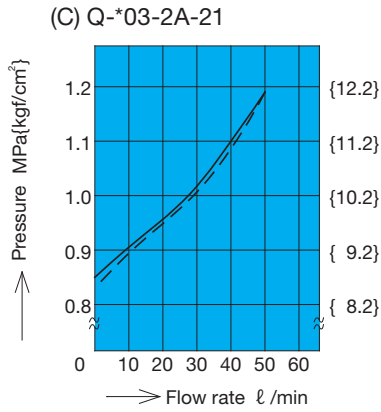

Pressure – Flow Rate Characteristics (— : Press rise
 (- - - : Pressure drop)

(C) Q-*06-2D-21

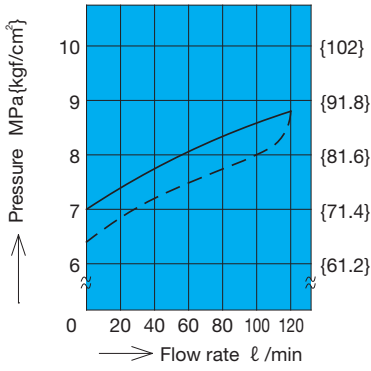

(C) Q-*06-2E-21

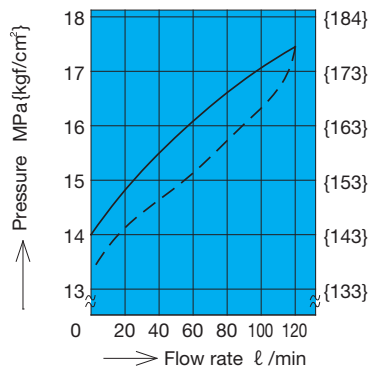

(C) Q-*10-2A-21

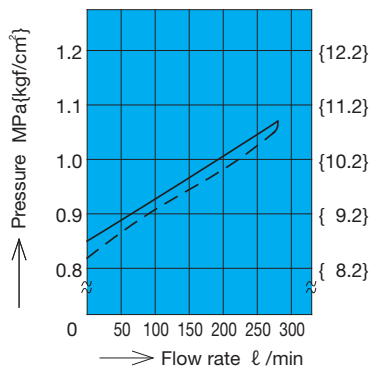

(C) Q-*10-2B-21

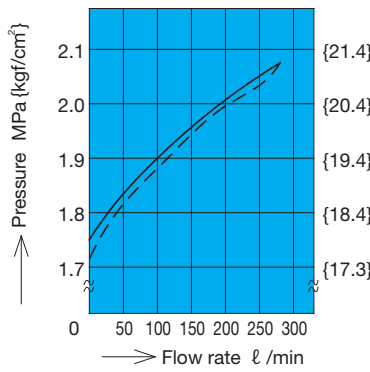

(C) Q-*10-2C-21

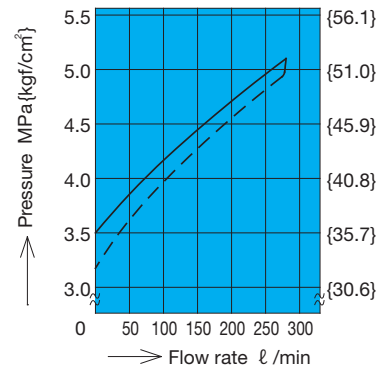

(C) Q-*10-2D-21

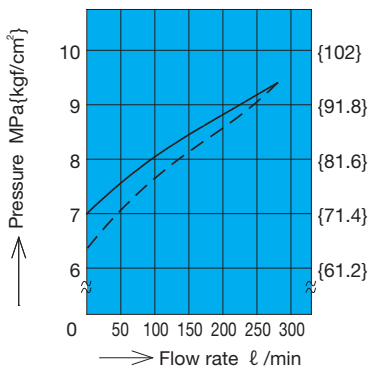

(C) Q-*10-2E-21

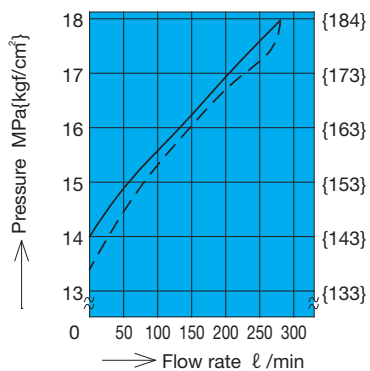

Pressure Control Valve

Cross-sectional Drawing

CQ-G**-**-21

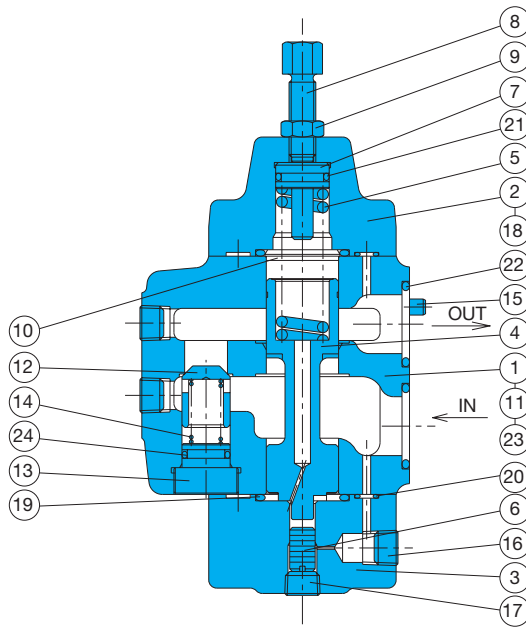

Part No.	Part Name
1	Body
2	Cover
3	Cover
4	Piston
5	Spring
6	Plunger
7	Push rod
8	Screw
9	Nut
10	Spacer
11	Nameplate
12	Poppet
13	Spring guide
14	Spring
15	Pin
16	Plug
17	Plug
18	Screw
19	O-ring
20	O-ring
21	O-ring
22	O-ring
23	O-ring
24	O-ring

Note) Part numbers 12, 13, 14, and 24 are not required when there is no check valve.

Note) The illustration shows the configuration for pressure adjustment ranges Type C, Type D, and Type E. For Type A and Type B, part number 6 plunger is eliminated, and the part number 4 piston, part number 5 spring are different.

Seal Part List (Kit Model Number RQBS-***C)

Part No.	Part Name	Type/Part Number						Q'ty
		CQ-G03**-**-21	CQ-T03**-**-21	CQ-G06**-**-21	CQ-T06**-**-21	CQ-G10**-**-21	CQ-T10**-**-21	
19	O-ring	NBR-90 P22	NBR-90 P22	NBR-90 G30	NBR-90 G30	NBR-90 P40	NBR-90 G40	2
20	O-ring	NBR-90 P6	NBR-90 P6	NBR-90 P6	NBR-90 P6	NBR-90 P6	NBR-90 P6	4
21	O-ring	NBR-90 P11	NBR-90 P11	NBR-90 P16	NBR-90 P16	NBR-90 P22A	NBR-90 P22A	1
22	O-ring	NBR-90 P20	-	NBR-90 P26	-	NBR-90 G35	-	2
23	O-ring	NBR-90 P12	-	NBR-90 P12	-	NBR-90 P12	-	2
24	O-ring	NBR-90 P11	NBR-90 P11	NBR-90 P14	NBR-90 P14	NBR-90 P22	NBR-90 P22	1

Note) The materials and hardness of the O-ring conforms with JIS B2401.
For the *** part of the kit number, specify the valve size (G03, T06). To specify inclusion of a check valve, add C to the end.