

### Pressure Reducing (and Check) Valve

20 to 280ℓ/min  
21MPa

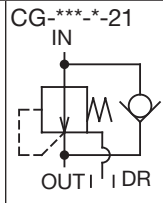

### Features

- ① This valve is used when part of the circuit uses pressure that is lower than the main circuit.
- ② Even when pressure changes in the primary main circuit, the reduced secondary pressure is adjusted automatically and maintained at a constant level.
- ③ Connecting a remote control valve to the vent port allows remote control of adjustment pressure.
- ④ The mounting surface of the gasket conforms to the ISO standards shown in the table below.

### Specifications

Model No.		Nominal Diameter (Size)	Maximum Working Pressure MPa{kgf/cm <sup>2</sup> }	Maximum Flow Rate ℓ/min	Pressure adjustment range MPa{kgf/cm <sup>2</sup> }	Weight kg		Gasket Surface Dimensions
Screw Mounting	Gasket Mounting					T Type	G Type	
(C) G-T03-A-21 B-21	(C) G-G03-A-21 B-21	3/8	21 {214} IN, OUT, Vent Port	20	0.25 to 1 {2.6 to 10.2} 0.3 to 2.5 {3.1 to 25.5}	3.3 (3.6)	3.9 (4.2)	ISO 5781-06-07-0-00
(C) G-T03-1-21 3-21	(C) G-G03-1-21 3-21	3/8		50	0.8 to 7 {8.2 to 71.4} 3.5 to 21 {35.7 to 214}	3.3 (3.6)	3.9 (4.2)	
(C) G-T06-1-21 3-21	(C) G-G06-1-21 3-21	3/4		120	0.8 to 7 {8.2 to 71.4} 3.5 to 21 {35.7 to 214}	5.7 (6.1)	6.2 (6.6)	ISO 5781-08-10-0-00
(C) G-T10-1-21 3-21	(C) G-G10-1-21 3-21	1¼		280	0.8 to 7 {8.2 to 71.4} 3.5 to 21 {35.7 to 214}	10.0 (11.3)	11.8 (13.1)	ISO 5781-10-13-0-00

Weight values in parentheses are for when a check valve is included. The cracking pressure of the check valve is 0.1MPa{1.0kgf/cm<sup>2</sup>}

### Explanation of model No.

(C)G - T 03 - 1 - 21

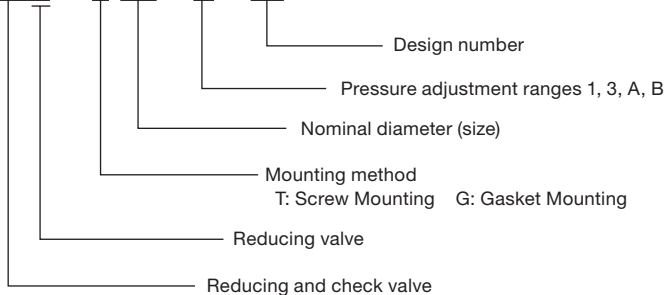

### ● Handling

- ① Provide an independent drain pipe directly to the tank.
- ② When using a remote control valve, connect piping to the reducing valve vent port. Pipe capacity can be a source of vibration. Use of thick iron pipe with an inside diameter of no more than 4mm and a connection length of no more than three meters is recommended.
- ③ Use the following table for specification when a sub plate is required.

### Installation Dimension Drawings

G-T\*\*\*-21 (Screw Mounting)

Model No.	Dimensions (mm)					
	A	B	C	D	E	F
G-T03-*-21	146	118.5	52	23	52.5	19
G-T06-*-21	174	148	66.5	27	64	24
G-T10-*-21	203.5	178.5	80.5	28	73	30

Model No.	Dimensions (mm)						
	G	H	J	K	L	M	P
G-T03-*-21	35	70	40	32	63	36	3/8
G-T06-*-21	47.5	95	50	37	73	54	3/4
G-T10-*-21	54	108	68.5	47.5	95	69	1¼

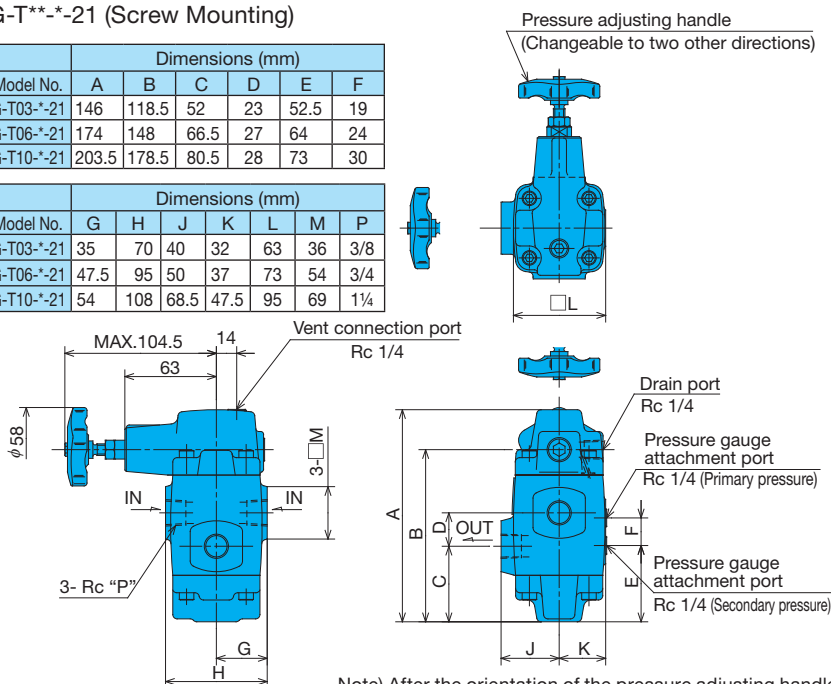

Note) After the orientation of the pressure adjusting handle has been changed, also modify the cover alignment surface O-ring (NBR-90 P6).

Model No.	Pipe Diameter	Weight kg	Applicable Pump Model
MG-03-20	3/8	1.6	(C) G-G03-*-21
MG-03X-20	1/2		
MG-06-20	3/4	3.9	(C) G-G06-*-21
MG-06X-20	1		
MG-10-20	1¼	6.7	(C) G-G10-*-21
MG-10X-20	1½		

These sub plates can also be used for pressure control valves.

- ④ The following are the bundled mounting bolts.

Model No.	Bolt Dimensions	Q'ty	Tightening Torque N·m{kgf·cm}
(C) G-G03-*-21	M10×75ℓ	4	45 to 55 {460 to 560}
(C) G-G06-*-21	M10×85ℓ	4	
(C) G-G10-*-21	M10×105ℓ	6	

Note) For mounting bolts, use bolts of 12.9 strength classification or equivalent.

G-G\*\*-\*-21 (Gasket Mounting)

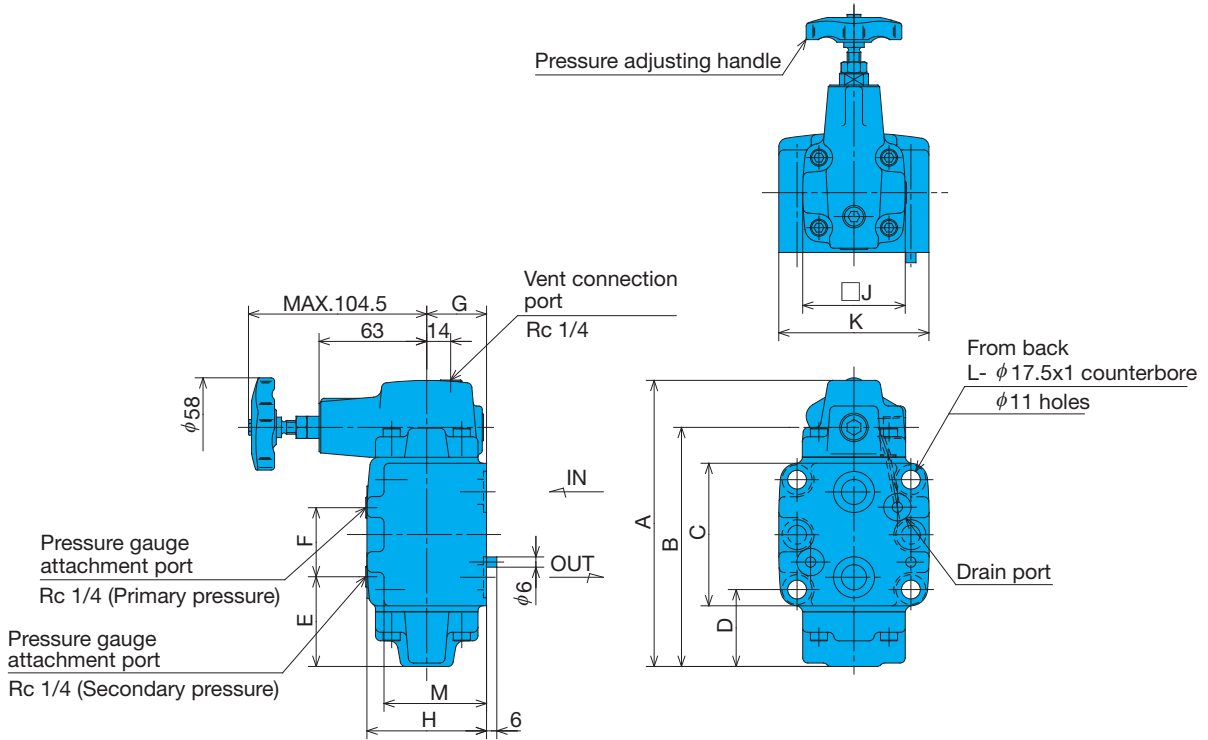

Model No.	A	B	C	D	E	F	G	H	J	K	L	M
G-G03-*-21	146	118.5	62	45.1	52.5	19	35	70	60	88	4	60
G-G06-*-21	174	148	82	51.4	64	24	40	80	70	102	4	70
G-G10-*-21	203.5	178.5	102	54	73	30	51	102	92	122	6	92

Note) The orientation of the pressure adjusting handle cannot be change.

CG-T\*\*-\*-21 (Screw Mounting)

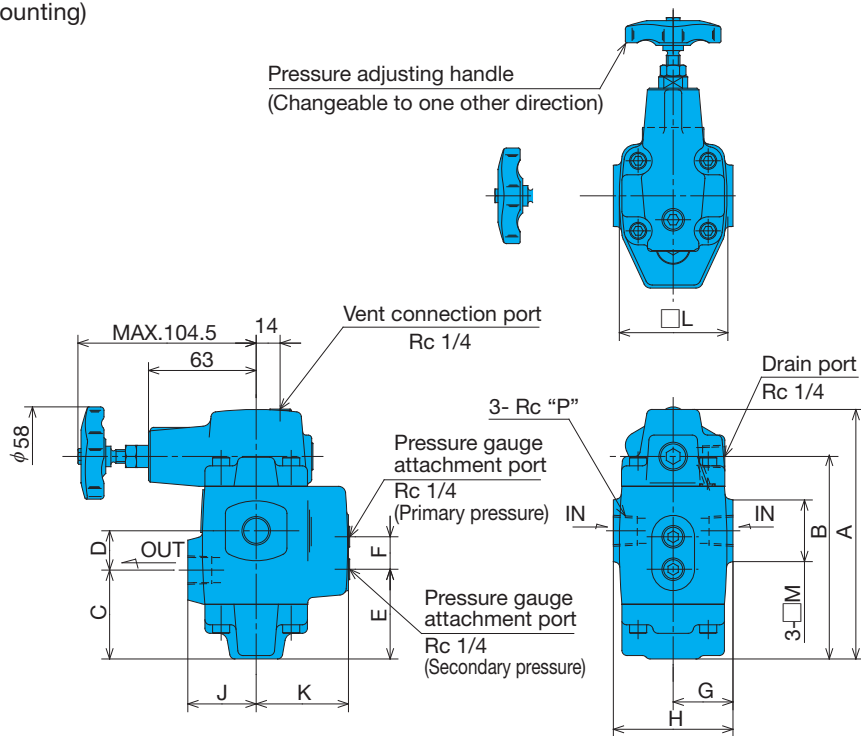

Model No.	A	B	C	D	E	F	G	H	J	K	L	M	P
CG-T03-*-21	146	118.5	52	23	52.5	19	35	70	40	54	63	36	3/8
CG-T06-*-21	174	148	66.5	27	64	24	47.5	95	50	60	73	54	3/4
CG-T10-*-21	203.5	178.5	80.5	28	73	30	54	108	68.5	80	95	69	1 1/4

Note) After the orientation of the pressure adjusting handle has been changed, also modify the cover alignment surface O-ring (NBR-90 P6).

CG-G\*\*-\*-21 (Gasket Mounting)

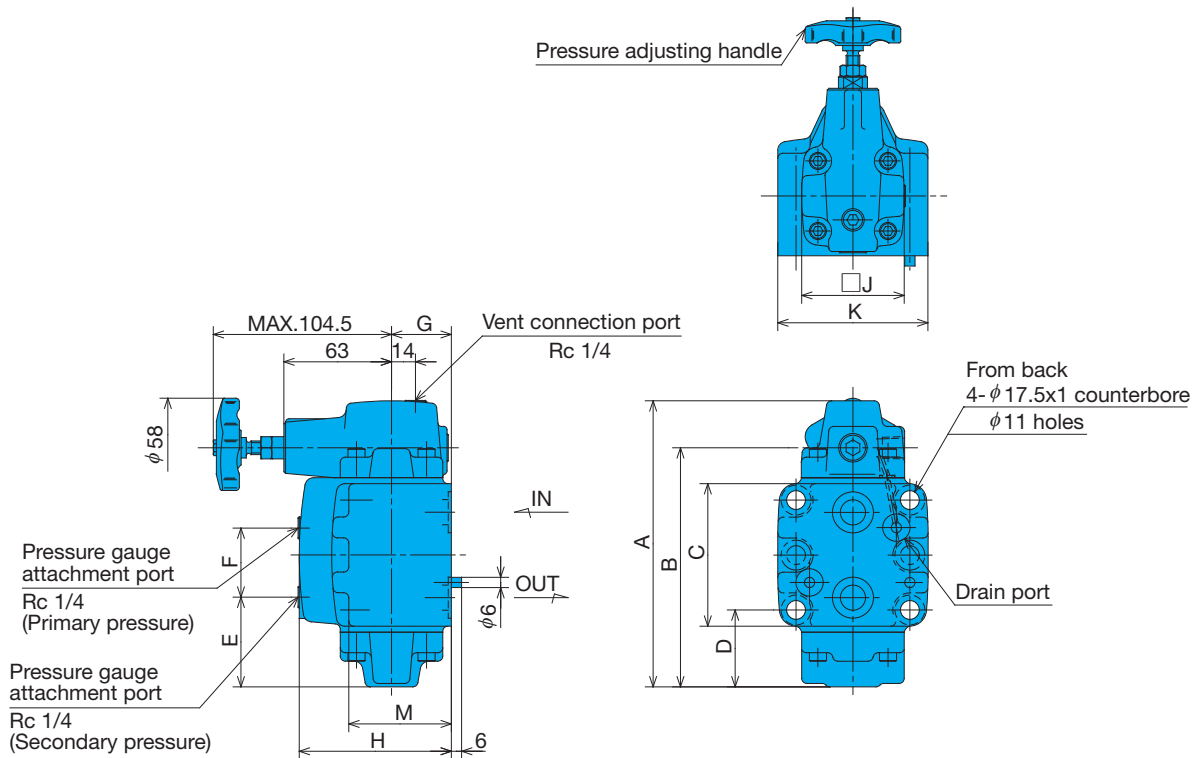

Model No.	Dimensions (mm)											
	A	B	C	D	E	F	G	H	J	K	L	M
CG-G03-*-21	146	118.5	62	45.1	52.5	19	35	89	60	88	4	60
CG-G06-*-21	174	148	82	51.4	64	24	40	100	70	102	4	70
CG-G10-*-21	203.5	178.5	102	54	73	30	51	131	92	122	6	92

Note) The orientation of the pressure adjusting handle cannot be change.

Sub Plate MG-\*\*\*-20

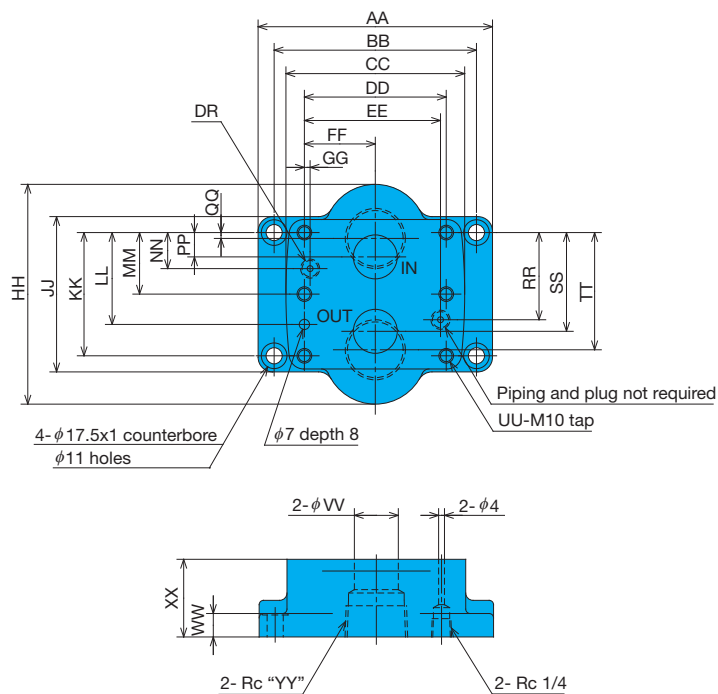

Model No.	Dimensions (mm)																						
	AA	BB	CC	DD	EE	FF	GG	HH	JJ	KK	LL	MM	NN	PP	QQ	RR	SS	TT	UU	VV	WW	XX	YY
MG-03-20	128	106.4	88	66.6	58.7	33.3	7.9	76	62	42.9	31.8	-	21.4	7.2	3.5	21.5	35.7	39.5	4	14	11	30	3/8
MG-03X-20																							1/2
MG-06-20	146	123.8	102	79.3	72.9	39.7	6.4	110	82	60.3	44.5	-	20.6	11.1	3.7	39.7	49.2	56.7	4	22	16	40	3/4
MG-06X-20																							1
MG-10-20	160	138.1	122	96.8	92.9	48.4	3.9	150	102	84.1	62.7	42.1	24.6	16.7	4.1	59.5	67.5	80.1	6	30	16	53	1/4
MG-10X-20																							1/2

# Performance Curves

Hydraulic Operating Fluid Kinematic Viscosity 32mm<sup>2</sup>/s

## Pressure Loss Characteristics

(C) G-G03-\*<sup>-</sup>-21

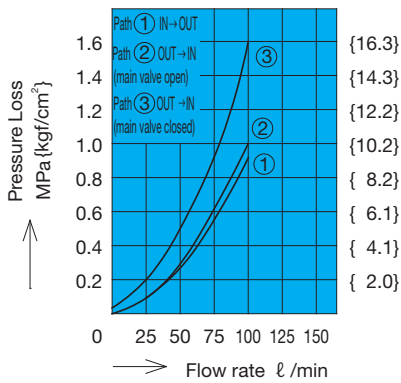

(C) G-G03-\*<sup>-</sup>-21

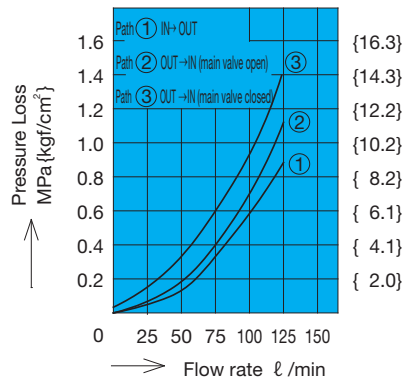

## Pressure – Drain Flow Rate Characteristics

(C) G-\*\*\*-\*<sup>-</sup>-21

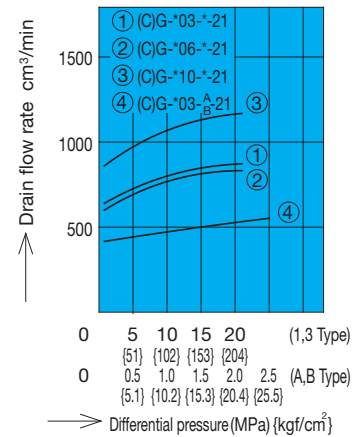

(C) G-G06-\*<sup>-</sup>-21

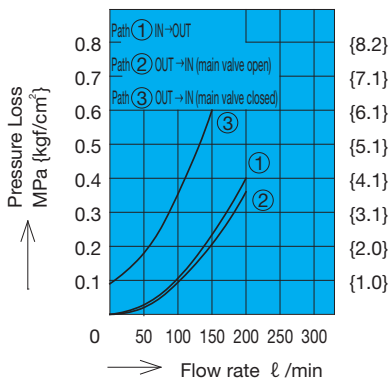

(C) G-T06-\*<sup>-</sup>-21

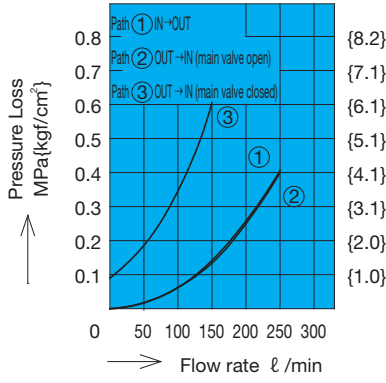

## Secondary Pressure – Flow Rate Characteristics

(C) G-\*03<sup>A</sup><sub>B</sub>-21

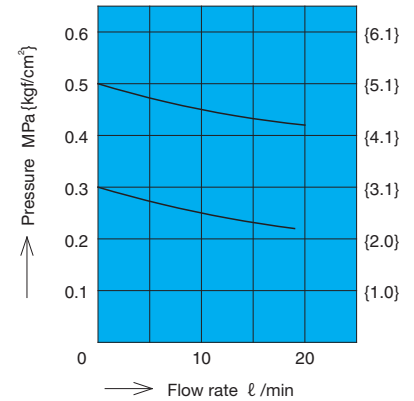

(C) G-G10-\*<sup>-</sup>-21

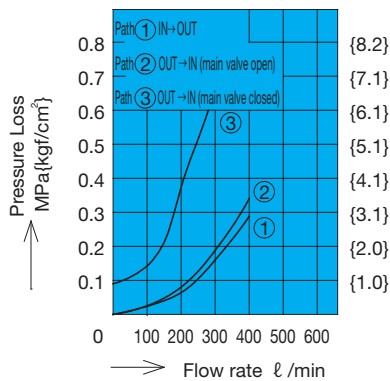

(C) G-T10-\*<sup>-</sup>-21

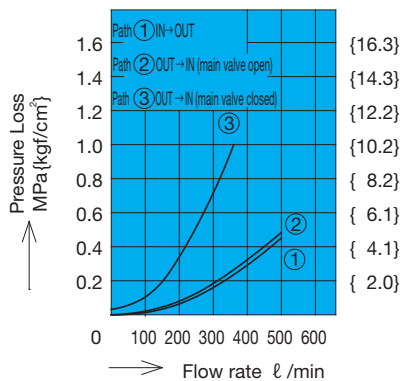

Pressure Control Valve

## Cross-sectional Drawings

(C) G-G\*\*<sup>A</sup><sub>B</sub>-21

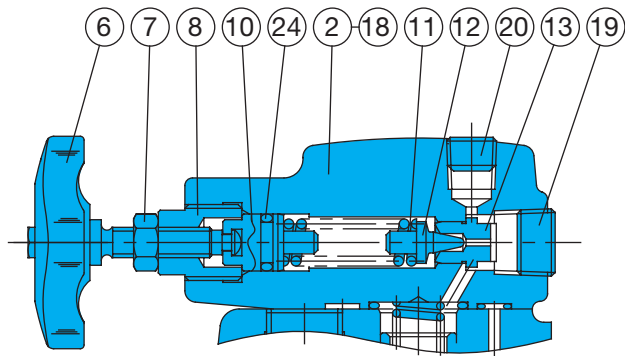

CG-G\*\*-\*-21

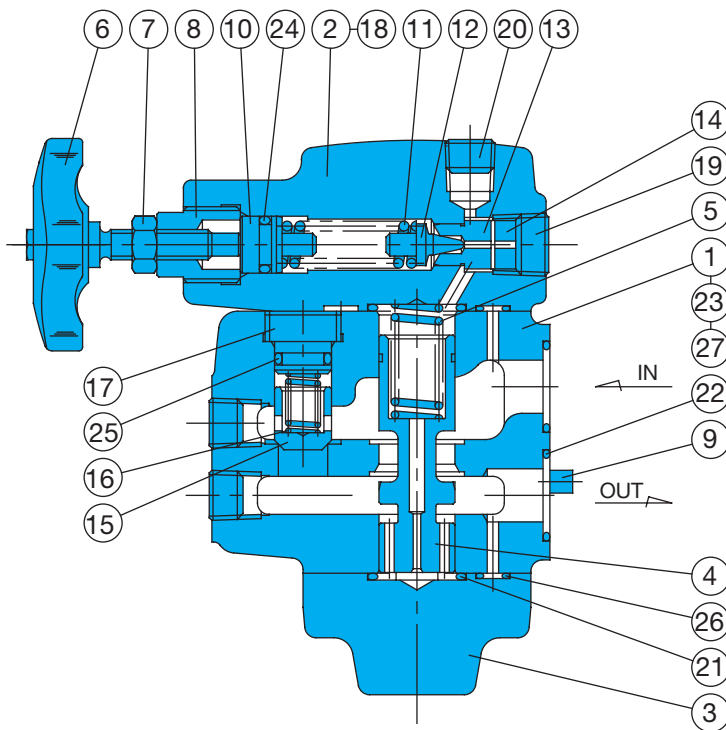

Part No.	Part Name
1	Body
2	Cover
3	Cover
4	Piston
5	Spring
6	Handle
7	Nut
8	Retainer
9	Spring pin
10	Push rod
11	Spring
12	Poppet
13	Seat
14	Collar
15	Poppet
16	Spring
17	Spring guide
18	Screw
19	Plug
20	Plug
21	O-ring
22	O-ring
23	O-ring
24	O-ring
25	O-ring
26	O-ring
27	Nameplate

Note) Part numbers 15, 16, 17, and 25 are not required when there is no check valve.

### Seal Part List (Kit Model Number RGSB-\*\*\*C)

Part No.	Part Name	Type/Part Number						Q'ty
		CG-G03-*-21	CG-T03-*-21	CG-G06-*-21	CG-T06-*-21	CG-G10-*-21	CG-T10-*-21	
21	O-ring	NBR-90 P22	NBR-90 P22	NBR-90 G30	NBR-90 G30	NBR-90 G40	NBR-90 G40	2
22	O-ring	NBR-90 P20	-	NBR-90 P26	-	NBR-90 G35	-	2
23	O-ring	NBR-90 P12	-	NBR-90 P12	-	NBR-90 P12	-	2
24	O-ring	NBR-70-1 P11	NBR-70-1 P11	NBR-70-1 P11	NBR-70-1 P11	NBR-70-1 P11	NBR-70-1 P11	1
25	O-ring	NBR-90 P11	NBR-90 P11	NBR-90 P14	NBR-90 P14	NBR-90 P22	NBR-90 P22	1
26	O-ring	NBR-90 P6	NBR-90 P6	NBR-90 P6	NBR-90 P6	NBR-90 P6	NBR-90 P6	4

Note) The materials and hardness of the O-ring conforms with JIS B2401.

\*\*\* in the kit number is used for specification of the valve size (G03, T06, etc.) To specify inclusion of a check valve, add C to the end.