

FT Type Flow Control (and Check) Valve (With Pressure and Temperature Compensation)

0.05 to 106ℓ/min
21MPa

Features

- ① Pressure compensation and temperature compensation mechanisms provide a stable control flow rate, even when oil temperature fluctuates.
- ② A wider control flow rate range as well as easier minute flow rate adjustability than previous products.

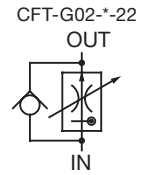

Specifications

Model No.	Nominal Diameter (Size)	Volume control flow rate ℓ/min	Maximum Working Pressure MPa(kgf/cm ²)	Reverse Flow Rate ℓ/min	Cracking pressure MPa(kgf/cm ²)	Weight kg	Gasket Surface Dimensions
(C)FT-G02- 8-22 30-22	1/4	0.05 to 8 0.1 to 30	21{214}	50	0.1{1.0}	3.7	ISO 6263-06-05-0-97
FT-G03- 42-22 106-22	3/8	0.1 to 42 0.2 to 106		*120		7.9	ISO 6263-07-09-0-97

Asterisk (*) indicates values for auxiliary plate with check valve.

● Handling

- ① In the temperature range of 20°C to 60°C, flow rate fluctuation is within ±5% of the standard flow rate at 40°C.
- ② In the pressure range of 1.0 to 21MPa {10.2 to 214kgf/cm²}, flow rate fluctuation is within ±5% of the setting flow rate.
- ③ Note that flow rate fluctuation exceeds the rated fluctuation amount slightly in the vicinity of the minimum control flow rate, due to changes in operating temperature and hydraulic fluid viscosity.
- ④ When controlling flow rates that are less than 0.2ℓ/min, use with a filter that does not exceed 10μm.
- ⑤ For flow rate control, make sure that the pressure differential between the input port and output port is at least 1MPa {10.2kgf/cm²}.
- ⑥ The control flow rate is increased by clockwise (rightward) rotation of the control handle.

- ⑦ See the table below for installation hex socket bolts.

- ⑧ Use the following table for specification when a sub plate is required.

● Sub Plate and Auxiliary Plate Application Table

Name	Model No.	Pipe Diameter	Recommended Flow Rate ℓ/min	Weight kg	Applicable Valve Type	Use With Sub Plate
Sub Plate	MF-02X-10	3/8	30	2.2	(C)FT-G02*-**-22	-
	MF-02Y-20	1/2	50			
Sub Plate	MF-03-10	3/8	42	3.3	FT-G03*-**-22	-
	MF-03Y-20	3/4	75			
	MF-03Z-20	1	120			
Sub Plate with Check Valve	MF-03Y-C-22	3/4	75	5.7		
	MF-03Z-C-22	1	120	5.6		
Auxiliary Plate A with Check Valve	MCF-03-A-22	φ 23	120	3.2		

- ⑨ Though FT-G03 does not have a built-in check valve, a sub plate with check valve and auxiliary plate with check

valve is used in addition to the normal sub-plate. (Use the auxiliary plate in combination with the sub plate.)

Applicable Model	Bolt Size	Q'ty	Tightening Torque N·m(kgf·cm)
(G)FT-G02*-**-22	M8 × 55ℓ	4	20 to 25{205 to 255}
FT-G03*-**-22	M10 × 75ℓ	4	45 to 55{460 to 560}
With FT-G03 Auxiliary Plate	M10 × 110ℓ	4	45 to 55{460 to 560}

Note) For mounting bolts, use bolts of 12.9 strength classification or equivalent.

Explanation of model No.

(C) FT - G 02 - 8 - (F) - 22

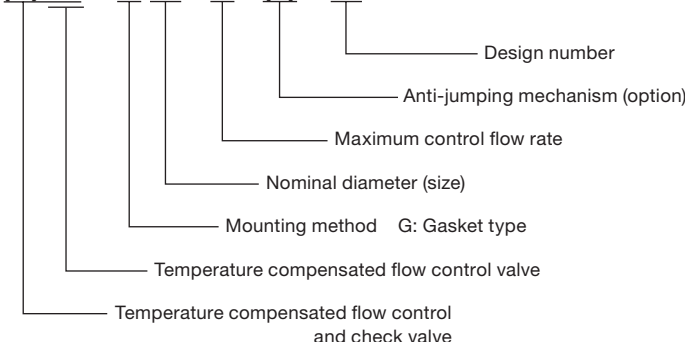

Installation Dimension Drawings

(C)FT-G02-**-22

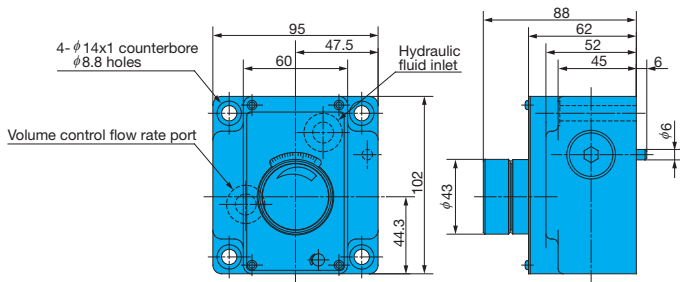

Sub Plate MF-02*-*

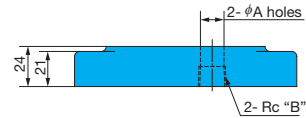
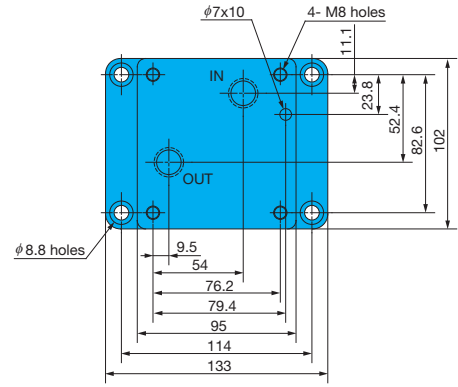

Sub Plate	A	B
MF-02X-10	14.7	3/8
MF-02Y-20	17	1/2

FT-G03-**-22

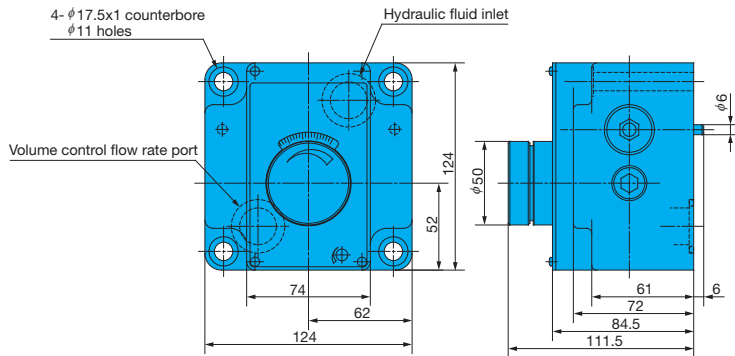

Anti-jumping mechanism

(C)FT-G02-*-F-22

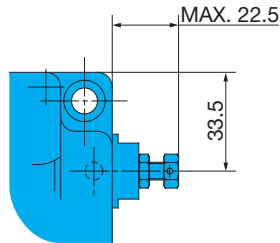

(C)FT-G03-*-F-22

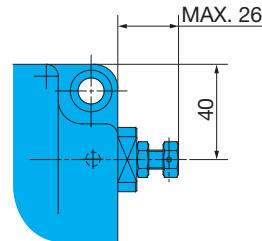

Sub Plate MF-03-10
MF-03Y-20

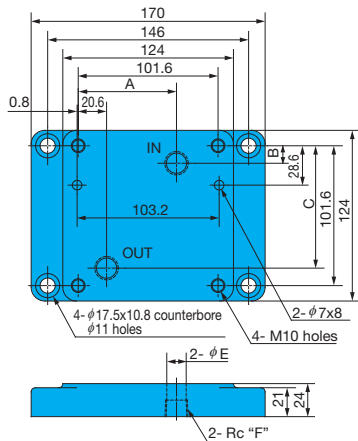

MF-03Z-20

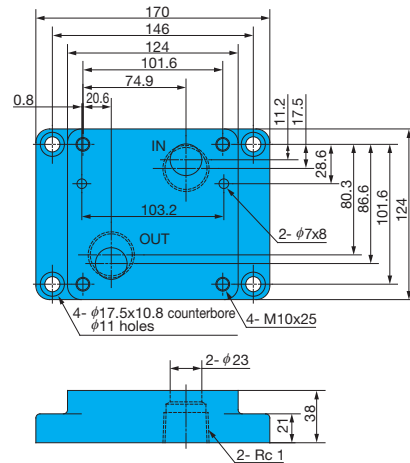

Sub Plate	A	B	C	E	F
MF-03-10	71.4	12.7	88.9	14.7	3/8
MF-03Y-20	74.9	11.2	86.6	23.0	3/4

Sub Plate with Check Valve MF-03*-C-22

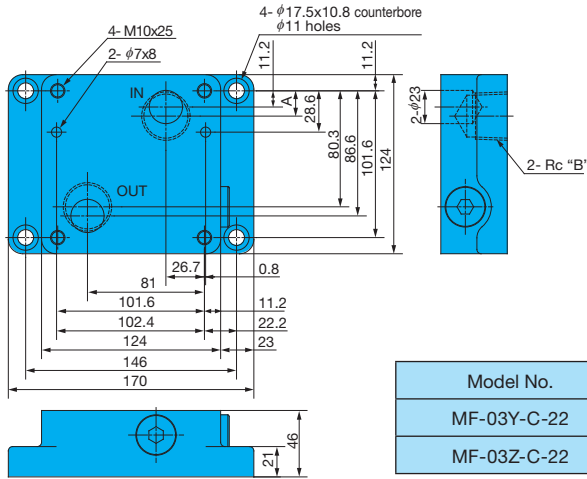

Auxiliary Plate with Check Valve MCF-03-A-22

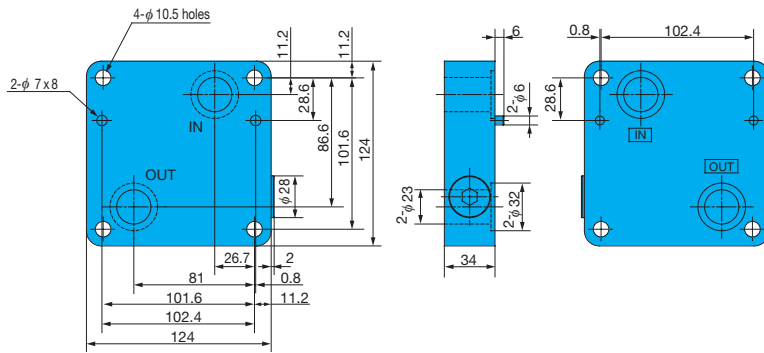

Performance Curves

Hydraulic Operating Fluid Kinematic Viscosity 32mm²/s

Oil Temperature – Control Flow Rate Characteristics

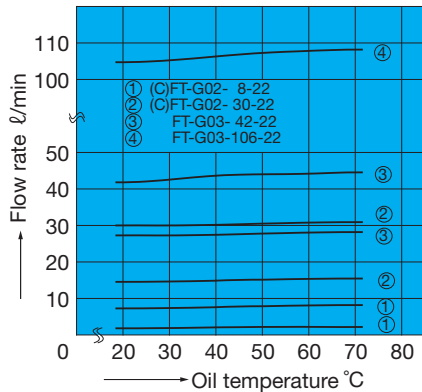

Pressure – Control Flow Rate Characteristics

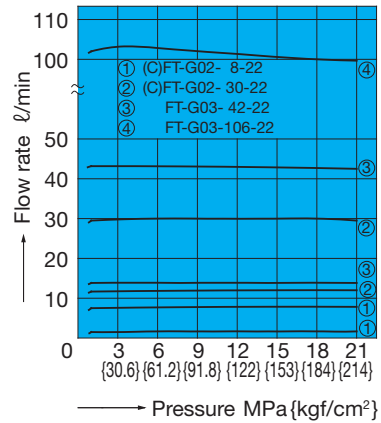

Scale – Control Flow Rate Characteristics

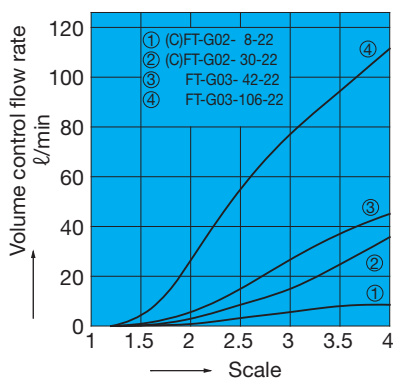

Pressure Loss Characteristics

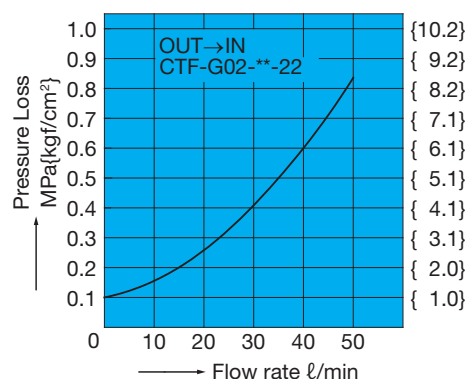

Cross-sectional Drawings

CFT-G02-*-22

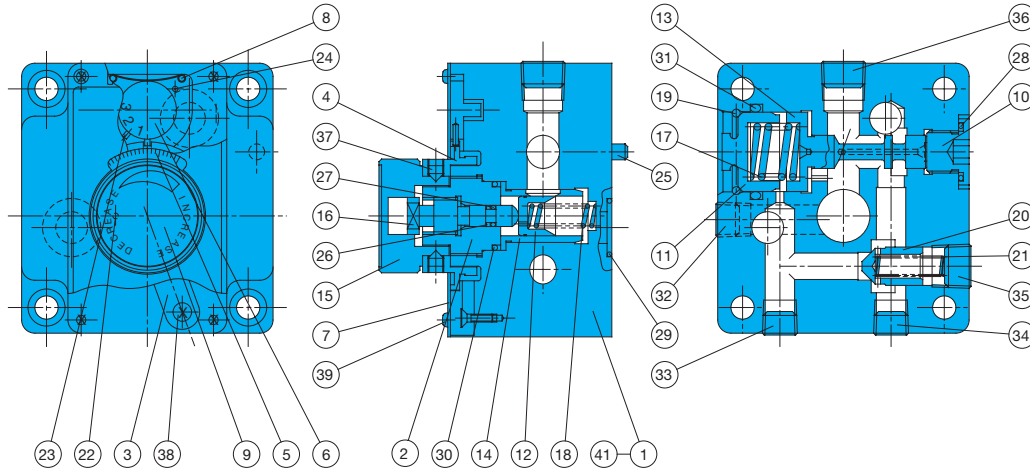

Part No.	Part Name	Part No.	Part Name	Part No.	Part Name
1	Body	15	Knob	29	O-ring
2	Retainer	16	Screw	30	O-ring
3	Stopper	17	Spring	31	O-ring
4	Dial	18	Spring	32	Plug
5	Plate	19	Snap ring	33	Plug
6	Plate	20	Poppet	34	Plug
7	Plate	21	Spring	35	Plug
8	Spring	22	Pin	36	Plug
9	Plate	23	Pin	37	Screw
10	Plug	24	Pin	38	Screw
11	Plug	25	Pin	39	Screw
12	Throttle	26	Backup ring	40	Washer
13	Piston	27	O-ring	41	O-ring
14	Sleeve	28	O-ring		

List of Sealing Parts

Part No.	Part Name	(C)FT-G02-*-22		FT-G03-*-22	
		Part Number	Q'ty	Part Number	Q'ty
26	Backup ring	T2-P5	1	T2-P5	1
27	O-ring	NBR-90 P5	1	NBR-90 P5	1
28	O-ring	NBR-90 P18	1	NBR-90 P20	1
29	O-ring	NBR-90 P18	2	NBR-90 P26	2
30	O-ring	NBR-90 P22	1	NBR-90 P26	1
31	O-ring	NBR-90 P30	1	NBR-90 P38	1
41	O-ring	-	-	NBR-90 P20	1
Seal Kit Number		FBBS-G02-1A		FBBS-G03	

Note) 1. The materials and hardness of the O-ring conforms with JIS B2401.
2. Backup ring indicates JIS B2407-T2**.

Anti-jumping mechanism

(C)FT-G02-*-F-22

(C)FT-G03-*-22

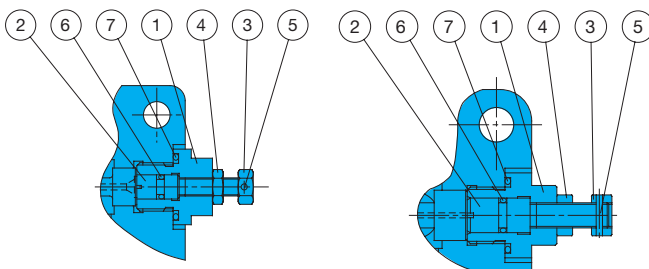

Anti-jumping mechanism

Part No.	Part Name
1	Retainer
2	Bolt
3	Nut
4	Nut
5	Spring pin
6	O-ring
7	O-ring

Sub Plate MF-03*-C-22

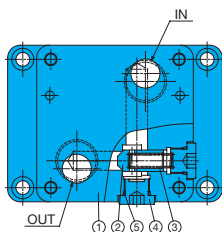

Part No.	Part Name	Part No.	Part Name
1	Sub Plate	4	Plug
2	Poppet	5	O-ring
3	Spring		

List of Sealing Parts

Part No.	Part Name	Part Number	Q'ty
5	O-ring	NBR-90 P18	2

MCF-03-A-22

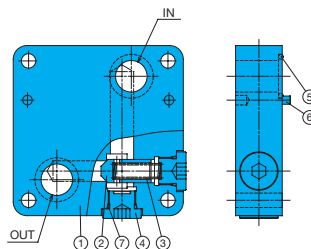

Part No.	Part Name
1	Sub Plate
2	Poppet
3	Spring
4	Plug
5	O-ring
6	Pin
7	O-ring
8	Screw

List of Sealing Parts

Part No.	Part Name	Part Number	Q'ty
5	O-ring	NBR-90 P26	2
7	O-ring	NBR-90 P18	2