

### Electro-hydraulic Proportional Flow Control Valve

0.5 to 500ℓ/min  
21MPa

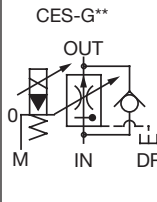
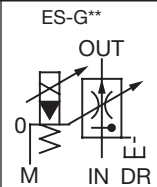

### Features

This valve controls actuator speed in response to the size of input current. Pressure and control oil temperature fluctuation has little effect on setting pressure, which enables high-precision

speed control. This valve is the perfect choice for actuator acceleration and deceleration control, and remote control.

#### ● Handling

##### 1 Air Bleeding

To enable proper pressure control, loosen the air vent when starting up the pump in order to bleed any air from the pump, and fill the inside of the solenoid with hydraulic operating fluid. The position of the air vent can change by loosening the M4 screw and rotating the cover.

##### 2 Manual Flow Rate Adjusting Screw

For the initial adjustment or when there is no input current to the valve due to an electrical problem or some other reason, the flow rate can be increased by rotating the manual adjustment screw clockwise (rightward). Normally, this adjusting screw should be returned completely to its original position and secured with the lock nut.

##### 3 Drain Port

Make sure that back pressure is no greater than 0.2MPa {2kgf/cm<sup>2</sup>}, and that this port is connected directly to the fluid tank at a point that is below the oil surface.

### Specifications

Item	Model No.	(C)ES-G02-10 30(F)-12	ES-G03-60 125(F)-12	(C)ES-G06-250-11	ES-G10-500(F)-11
Maximum Operating Pressure MPa(kgf/cm <sup>2</sup> )		21{214}	21{214}	21{214}	21{214}
Flow Rate Control Range ℓ/min		0.5 to 10/0.5 to 30	2 to 60/2 to 125	5 to 250	15 to 500
Minimum Allowable Valve Pressure Differential MPa(kgf/cm <sup>2</sup> )		1.0{10}(Note1)	1.3{13.3}(Note1)	1.5{15.3}(Note1)	2{20.4}(Note1)
Reverse Flow Rate ℓ/min (With check valve only)		50	(125)(Note3)	200	-
Hysteresis %		3 max. (Note 2)	3 max. (Note 2)	3 max. (Note 2)	3 max. (Note 2)
Rated Current mA		800	800	800	800
Coil Resistance Ω		20 (20°C)	20 (20°C)	20 (20°C)	20 (20°C)
Weight kg		8.5	13	25	55

Note) 1. Control valve inlet and outlet pressure differential required to obtain favorable pressure compensation.  
2. Value when a Nachi-Fujikoshi special amplifier is used (with dithering).  
3. ES-G03 does not have a built-in check valve, but a sub plate with check valve (Model No. MCF-03-D-22) is available for it.

### Explanation of model No.

**(C)ES - G 02 - 30 - (F) - 12**

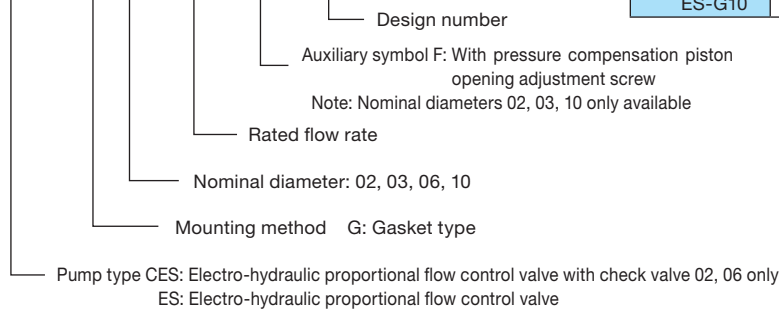

Model No.	Bolt Size	Q'ty	Tightening Torque N·m(kgf·cm)
(C)ES-G02	M 8× 80ℓ	4	20 to 25{ 205 to 255}
ES-G03	M10× 75ℓ	4	45 to 55{ 460 to 560}
(C)ES-G06	M16×140ℓ	4	190 to 235{1940 to 2400}
ES-G10	M20×160ℓ	4	370 to 460{3770 to 4690}

##### 4 Bundled Accessories (Valve Mounting Bolts)

5 The loss coefficient and control valve can cause resonance when there is a great distance between the flow control valve and actuator (when the pipe internal volume is large). Be sure to keep the distance between the flow control valve and actuator as small as possible, and to avoid the use of flexible hose as much as possible.

##### 6 Sub Plate

See the next page for more information about sub plates.

7 Use an operating fluid that conforms to the both of the following. Oil temperature: -20 to 70°C Kinematic Viscosity: 12 to 400mm<sup>2</sup>/s. The recommended kinematic viscosity range is 15 to 60mm<sup>2</sup>/s.

8 Since this valve has a built-in pressure compensation valve, changing of the inertial load (using a high inertial oil motor, etc.) can create the risk of hunching under certain conditions. Contact your sales agent before changing the inertial load.

Note) Use a hex wrench that has a width across flats of 8 to adjust the aperture adjustment screw of nominal diameter 10.

### Installation Dimension Drawings

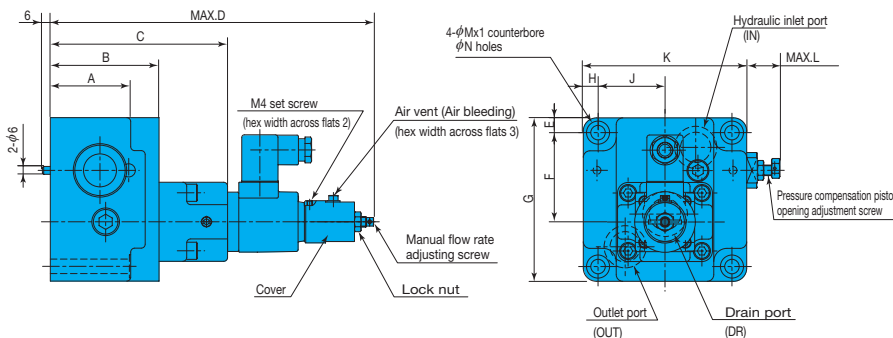

Model No.	A	B	C	D	E	F	G	H	J	K	L	M	N
(C)ES-G02	66	80	132	242.8	9.7	48	102	9.4	38.1	95	22.5	14	8.8
ES-G03	61	82.5	134.5	245.3	11.2	67.8	124	11.2	50.8	124	26	17.5	11
(C)ES-G06	115	130	182	292.8	16.8	104.8	167	17	73	180	-	26	18
ES-G10	137	160	215	326.3	25	148	228	23.5	98.5	244	18	32	22

The gasket surface dimensions comply with the ISO standard shown below.

(C) ES-G02...ISO 6263-06-05-0-97  
ES-G03...ISO 6263-07-09-0-97  
(C) ES-G06...ISO 6263-08-13-0-97

Sub Plate  
MES-02\*-10

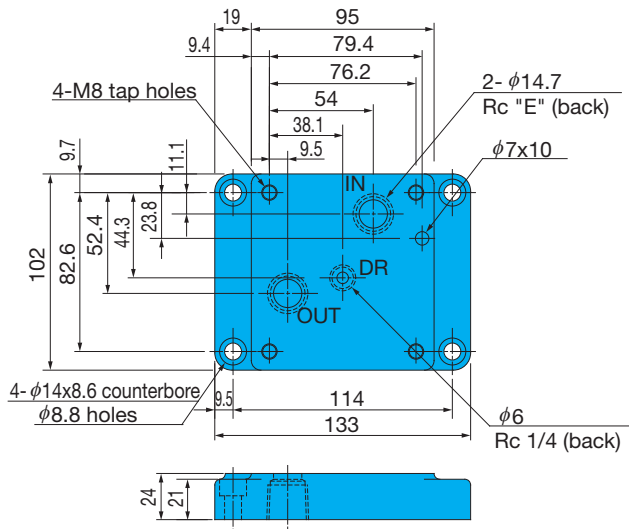

MES-03\*-10

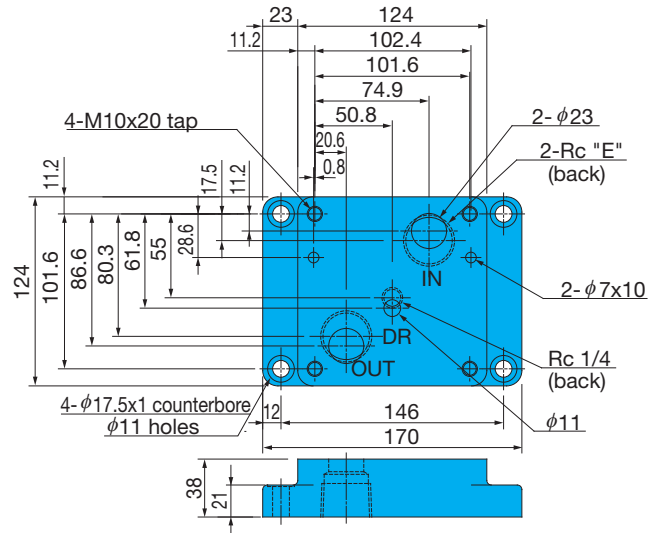

Model No.	E
MES-02X-10	3/8
MES-02Y-10	1/2

Model No.	E
MES-03Y-10	3/4
MES-03Z-10	1

MES-06\*-10

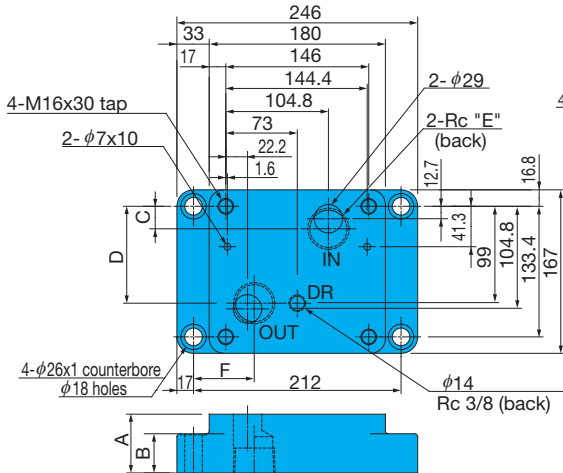

Model No.	A	B	C	D	E	F
MES-06X-10	45	25	16	104.8	1	55.2
MES-06Y-10	60	40	23	99	1 1/4	62

Auxiliary Plate with Check Valve  
MCF-03-D-22

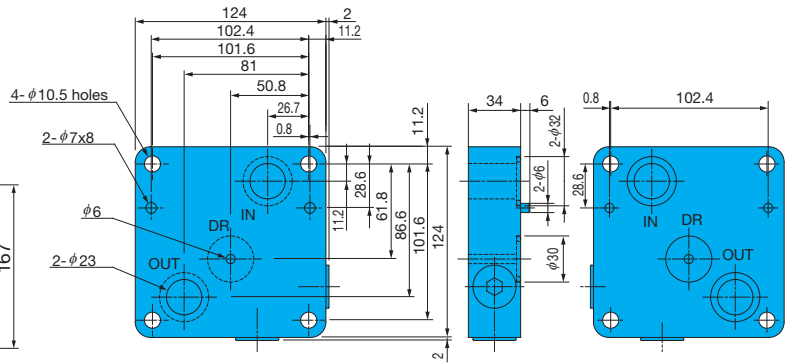

Bundled Items (Mounting Bolts) M10 x 110ℓ (Four)

ES-G10 Mounting Gasket Surface Dimensions

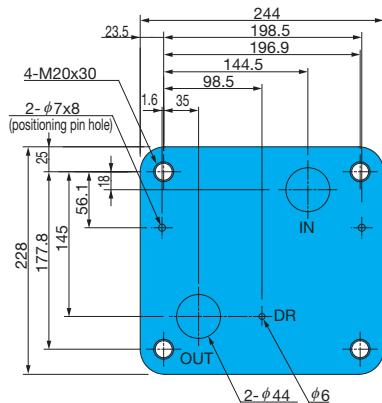

# Performance Curves

Hydraulic Operating Fluid Kinematic Viscosity 32mm<sup>2</sup>/s

## Input Current – Flow Rate Characteristics

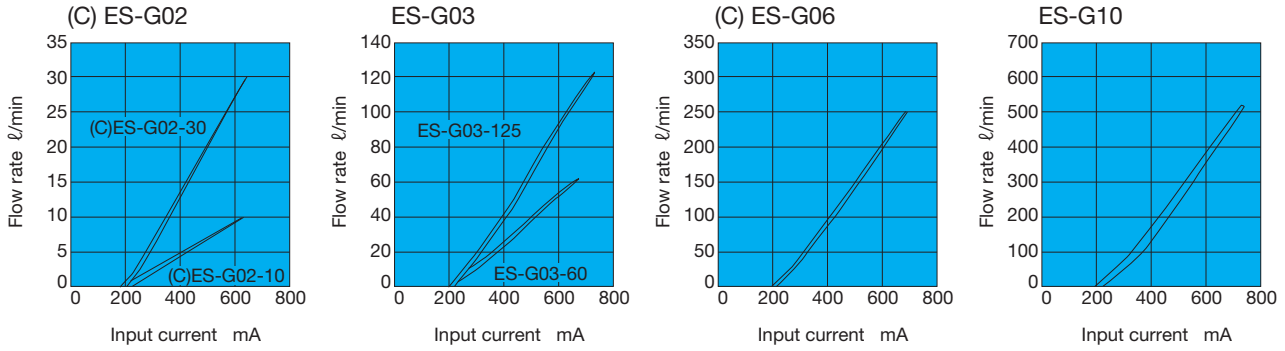

## Oil Temperature – Control Flow Rate Characteristics

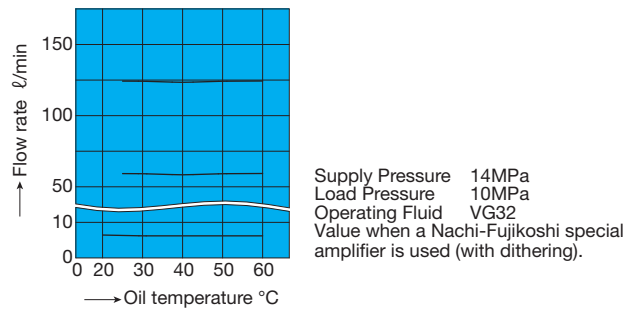

## Pressure – Control Flow Rate Characteristics

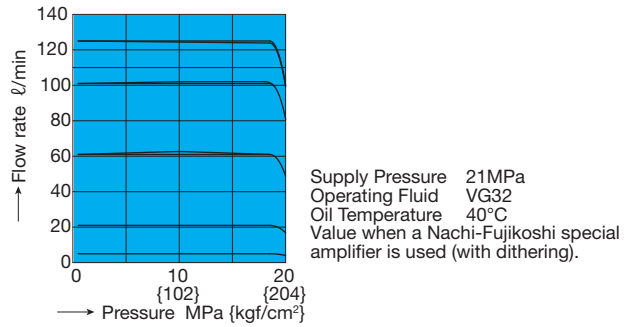

# Cross-sectional Drawing

ES-G\*\*-\*-11 (12)

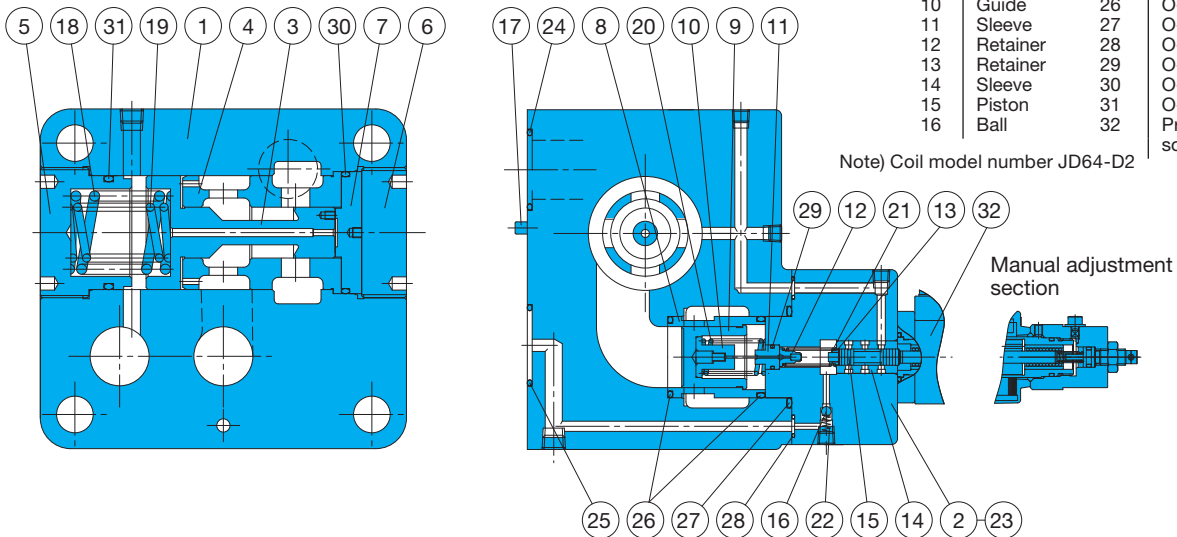

Part No.	Part Name	Part No.	Part Name
1	Body	17	Pin
2	Cover	18	Spring
3	Piston	19	Spring
4	Sleeve	20	Spring
5	Plug	21	Spring
6	Plug	22	Spring
7	Retainer	23	Spring
8	Sleeve	24	O-ring
9	Spool	25	O-ring
10	Guide	26	O-ring
11	Sleeve	27	O-ring
12	Retainer	28	O-ring
13	Retainer	29	O-ring
14	Sleeve	30	O-ring
15	Piston	31	O-ring
16	Ball	32	Proportional solenoid

Note) Coil model number JD64-D2

Manual adjustment section

## List of Sealing Parts

Part No.	Part Name	(C) ES-G02		ES-G03		(C) ES-G06		ES-G10	
		Part Number	Q'ty	Part Number	Q'ty	Part Number	Q'ty	Part Number	Q'ty
24	O-ring	NBR-90 P18	2	NBR-90 P26	2	NBR-90 G35	2	NBR-90 P48	2
25	O-ring	NBR-90 P24	1	NBR-90 P28	1	NBR-90 G35	1	NBR-90 P48	1
26	O-ring	-	-	-	-	NBR-90 G35	2	NBR-90 G50	2
27	O-ring	NBR-90 P29	1	NBR-90 P29	1	NBR-90 G45	1	NBR-90 G60	1
28	O-ring	NBR-90 P5	4	NBR-90 P5	4	NBR-90 P8	3	NBR-90 P9	3
29	O-ring	NBR-90 P9	1	NBR-90 P9	1	NBR-90 P9	1	NBR-90 P9	1
30	O-ring	NBR-90 P18	1	NBR-90 P20	1	NBR-90 G55	1	NBR-90 G75	2
31	O-ring	NBR-90 P30	1	NBR-90 P38	1	NBR-90 P50	1	NBR-90 G75	1
Seal Kit Number		JFS-G02		JFS-G03		JFS-G06		JFS-G10	

Note) The materials and hardness of the O-ring conforms with JIS B2401.