

Plunger and hand lever

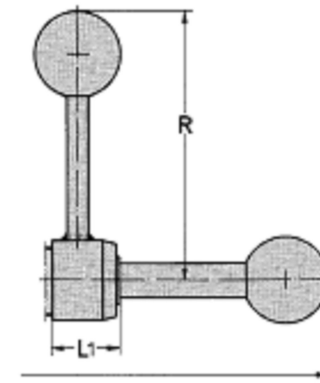

A	50	D4	36
A1~	75	D5	M12
A2~	13	E	35
A3~	20	H~	71
A4	15	L1	35
B	90	R	197
B1~	115	S2	3
B2	69	S3	3
D(h8)	22	T	25
D1	60	T1	1
D3	11	S1	4

NOTES :

1. MAX. HOLDING CAPACITY : [4045 lbs] 18000 N
2. CLAMPING FORCE (FS) : [675 lbs] 3000 N
3. OPERATING FORCE (FB) : [22 lbs] 100 N
4. WEIGHT : [5.85 lbs] 2,655 N
5. OPERATING METHOD : PLUNGER AND HAND LEVER
6. PLUNGER ORDER SEPARATELY
7. DIMENSIONS AND TOLERANCES SUBJECT TO CHANGE WITHOUT PRIOR NOTICE

RAPID STROKES (S)	100	200	300
STROKES (L)	295	395	495
FOR PLUNGER WEIGHT [lbs] Kg	[2.20] 1,000	[2.40] 1,090	[3.06] 1,390

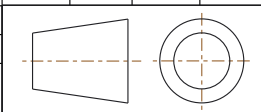

COMPONENT Variable Stroke Straight Line Action Clamps



15 Corporate Drive,
Auburn Hills, MI 48326, USA
Phone: 888-337-8226, Fax: 800-682-9689
www.destaco.com

This Drawing is the Property of DESTACO.
It contains confidential, proprietary information that is DESTACO property. Do not disclose to or duplicate for others except as authorized by DESTACO.

DIMENSIONS : [IN] MM

TOLERANCES : \pm [0.020] 0.51

FO-220

FO-SERIES

REV

02/20/19

SHEET

1 of 1