

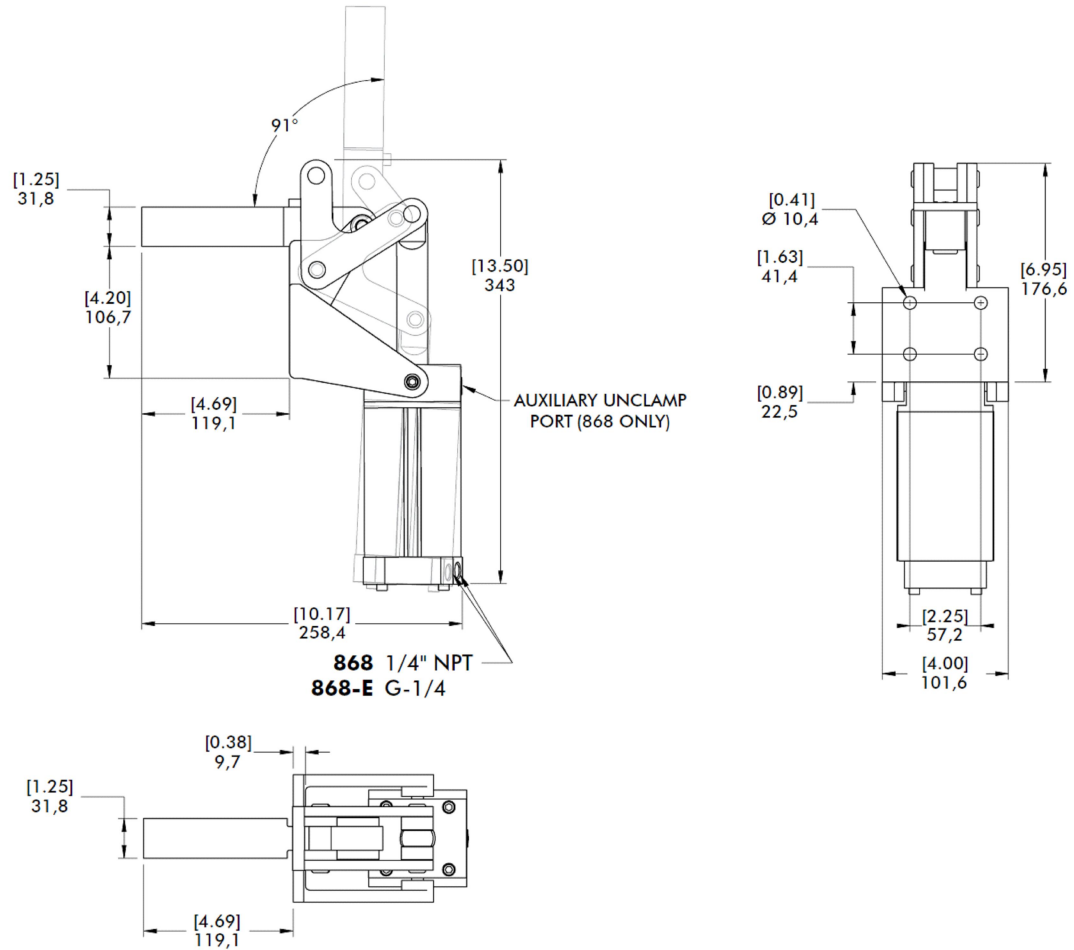

CLOSED POSITION

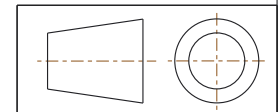

NOTES :

1. MAX. HOLDING CAPACITY INNER : [4,000 lbf] 17800 N
2. MAX. HOLDING CAPACITY OUTER : [2400 lbf] 10675 N
3. MAXIMUM EXERTING FORCE INNER @ [72 PSI] 5 bar : [1704 lbf] 7637 N
4. MAXIMUM EXERTING FORCE OUTER @ [72 PSI] 5 bar : [800 lbf] 3585 N
5. WEIGHT : [17.0 lb] 7,71 kg
6. BORE SIZE : [2.48] 63
7. AIR CONSUMPTION : [0.109 ft³] 3,08 dm³
8. PORT SIZE : 1/4 NPT
9. REFER CATALOG PAGE FOR MORE DETAILS
10. DIMENSIONS AND TOLERANCES SUBJECT TO CHANGE WITHOUT PRIOR NOTICE



 <p>15 Corporate Drive, Auburn Hills, MI 48326, USA Phone: 888-337-8226, Fax: 800-682-9689 www.destaco.com</p>	<p>This Drawing is the Property of DESTACO. It contains confidential, proprietary information that is DESTACO property. Do not disclose to or duplicate for others except as authorized by DESTACO.</p>	COMPONENT		Pneumatic Toggle Clamps		
		DIMENSIONS : [IN] MM		868		REV
		TOLERANCES : ±[0.020] 0.51		868-SERIES		11/04/19
						SHEET
				1 of 1		