

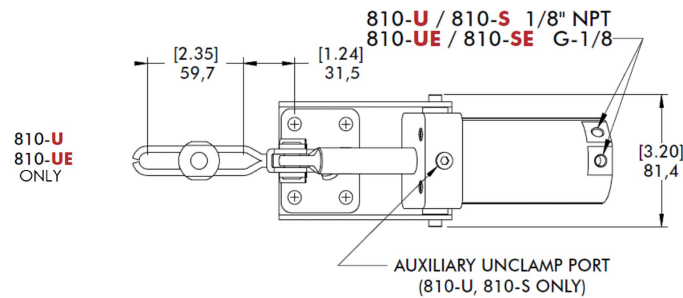

CLOSED POSITION

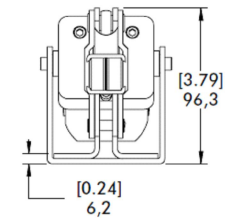
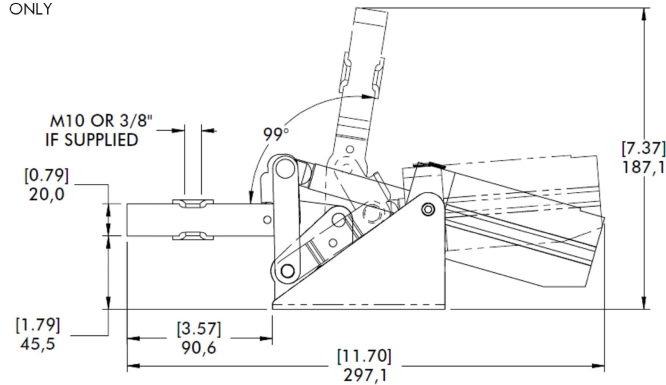
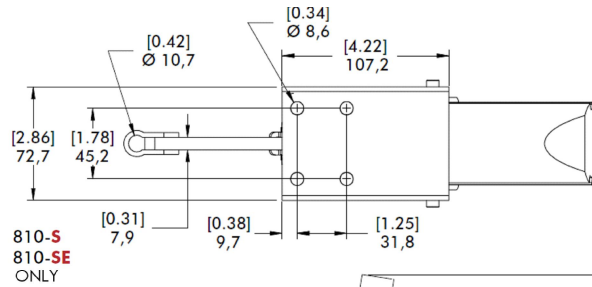
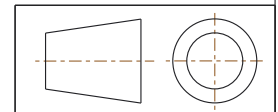

NOTES :

1. MAX. HOLDING CAPACITY INNER : [600 lbf] 2670 N
2. MAX. HOLDING CAPACITY OUTER : [290 lbf] 1290 N
3. MAXIMUM EXERTING FORCE INNER @ [72 PSI] 5 bar : [856 lbf] 3834 N
4. MAXIMUM EXERTING FORCE OUTER @ [72 PSI] 5 bar : [407 lbf] 1823 N
5. WEIGHT : [4.07 lb] 1,85 kg
6. BORE SIZE : [1.57] 40
7. AIR CONSUMPTION : [0.029 ft³] 0,83 dm³
8. PORT SIZE : 1/8 NPT
9. REFER CATALOG PAGE FOR MORE DETAILS
10. DIMENSIONS AND TOLERANCES SUBJECT TO CHANGE WITHOUT PRIOR NOTICE



 <p> 15 Corporate Drive, Auburn Hills, MI 48326, USA Phone: 888-337-8226, Fax: 800-682-9689 www.destaco.com </p>	<p>This Drawing is the Property of DESTACO. It contains confidential, proprietary information that is DESTACO property. Do not disclose to or duplicate for others except as authorized by DESTACO.</p>	<p>COMPONENT Pneumatic Toggle Clamps</p>		
		<p>810-U</p>		<p>REV</p>
		<p>810-SERIES</p>		<p>11/04/19</p>
		<p>DIMENSIONS : [IN] MM</p>		<p>SHEET</p>
<p>TOLERANCES : \pm[0.020] 0.51</p>		<p>1 of 1</p>		