

CLOSED POSITION

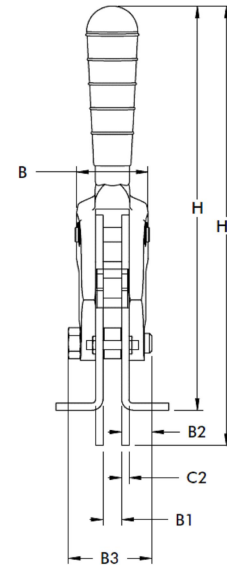

A	[1.77] 45	C3	[0.59] 15
A1	[2.95] 74,9	C4	[0.79] 20,1
A3	[0.59] 15	C5	[2.95] 74,9
A4	N/A	C6	N/A
A8	[0.18] 4,6	C7	[3.44] 87,4
B	[1.89] 48	D	[0.30] 7,6
B1	[0.47] 11,9	D1	[0.41] 10,4
B2	[0.89] 22,6	D2	[0.43] 10,9
B3	[2.13] 54,1	D3	[0.79] 20,1
B4	N/A	F1	[0.47] 11,9
B5	N/A	H	N/A
C	N/A	H1	[11.26] 286
C1	[0.98] 24,9	L	[6.30] 160
C2	[0.19] 4,8	L1	[3.35] 85,1

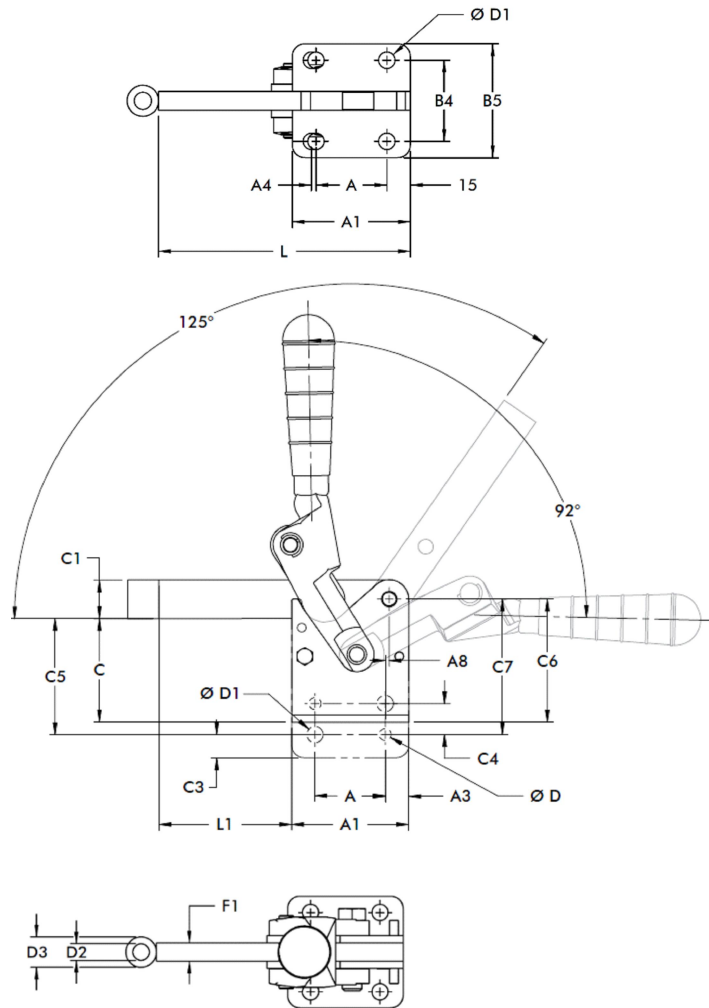
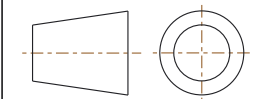

NOTES :

1. MAX. HOLDING CAPACITY : 10000 N [2250 lbf]
2. CLAMP BAR OPENING (+ 10°) : 120°
3. HANDLE OPENING (+ 10°) : 90°
4. WEIGHT : 1,85 kg [4.087 lbs]
5. DIMENSIONS AND TOLERANCES SUBJECT TO CHANGE WITHOUT PRIOR NOTICE

COMPONENT

Heavy-Duty Vertical Hold Down Clamps

DIMENSIONS : [IN] MM

535-LB

REV

01/28/19

TOLERANCES : ±[0.020] 0.51

535-SERIES

SHEET

1 of 1



15 Corporate Drive,
Auburn Hills, MI 48326, USA
Phone: 888-337-8226, Fax: 800-682-9689
www.destaco.com

This Drawing is the Property of DESTACO.
It contains confidential, proprietary
information that is DESTACO property. Do
not disclose to or duplicate for others
except as authorized by DESTACO.