

CLOSED POSITION

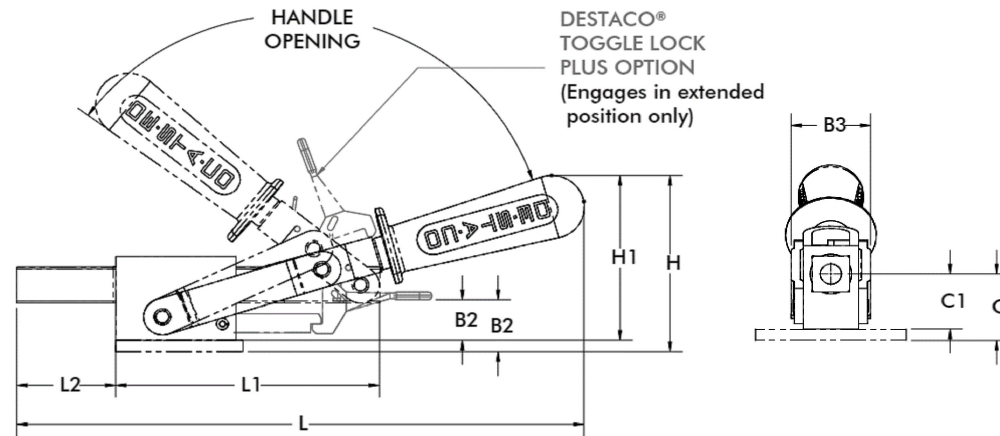

A	44.5 [1.75]	C1	N/A
A1	64 [2.52]	D	10.5 [0.41]
A3	9.8 [0.38]	D1	19 [0.75]
B	58.7 [2.31]	H	97.5 [3.84]
B1	76 [2.99]	H1	N/A
B2	N/A	L	331.4 [13.05]
B3	39 [1.54]	L1	167 [6.58]
C	35 [1.38]	L2	82.2 [3.24]

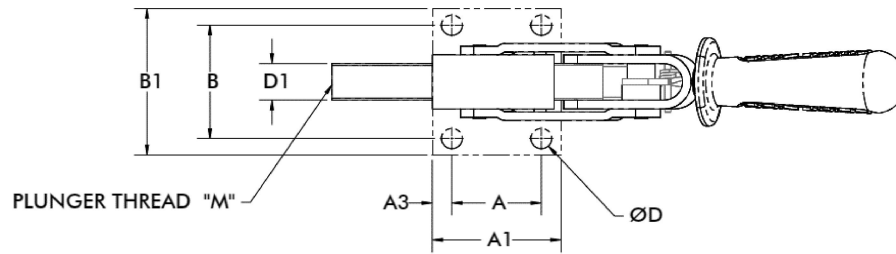
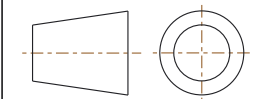

NOTES :

1. MAX. HOLDING CAPACITY : [5800 lbf] 25800 N
2. WEIGHT : [2.68 lbs] 1,22 kg
3. PLUNGER TRAVEL : [1.91] 48,4
4. HANDLE OPENING : 125°
5. DIMENSIONS AND TOLERANCES SUBJECT TO CHANGE WITHOUT PRIOR NOTICE

COMPONENT

Heavy-Duty Straight Line Action Clamps



15 Corporate Drive,
Auburn Hills, MI 48326, USA
Phone: 888-337-8226, Fax: 800-682-9689
www.destaco.com

This Drawing is the Property of DESTACO.
It contains confidential, proprietary
information that is DESTACO property. Do
not disclose to or duplicate for others
except as authorized by DESTACO.

DIMENSIONS : [IN] MM

TOLERANCES : ±[0.020] 0.51

5150-MBR

5150-SERIES

REV

03/19/19

SHEET

1 of 1