

CLOSED POSITION

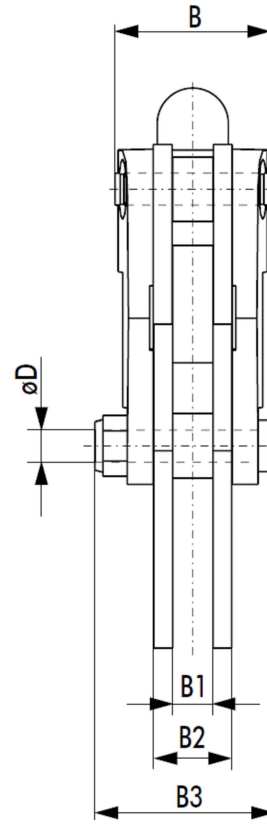

LSC-VERSION

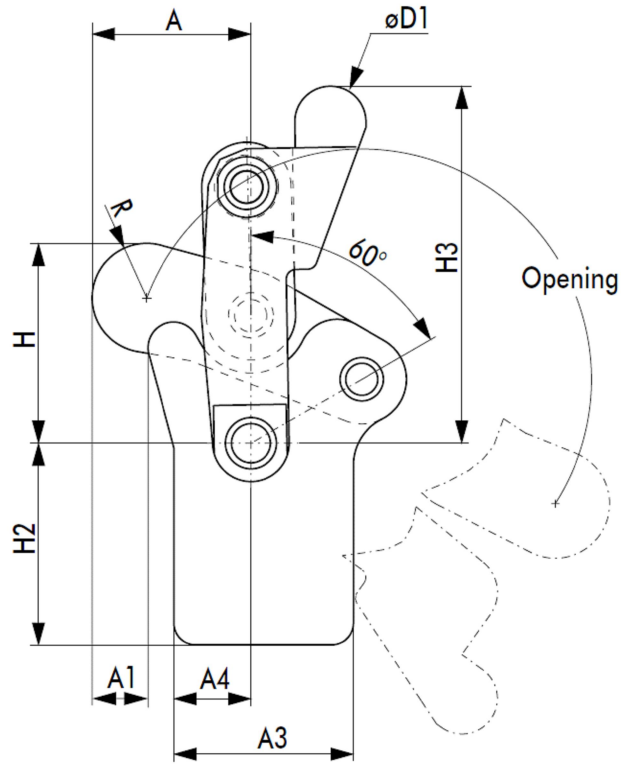
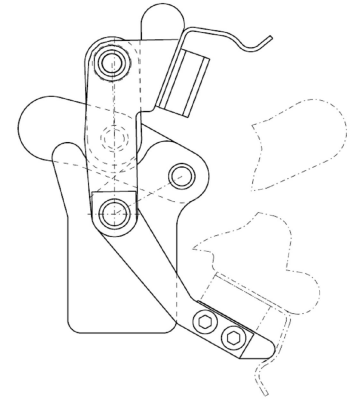

NOTES :

1. MAX. HOLDING CAPACITY : 11000 N [2475 lbf]
2. CLAMP BAR OPENING (+ 10°) : 200°
3. WEIGHT : 1,60 Kg [3.53 lbs]
4. DIMENSIONS AND TOLERANCES SUBJECT TO CHANGE WITHOUT PRIOR NOTICE

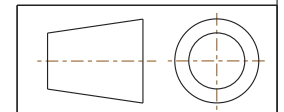

15 Corporate Drive,
Auburn Hills, MI 48326, USA
Phone: 888-337-8226, Fax: 800-682-9689
www.destaco.com

This Drawing is the Property of DESTACO.
It contains confidential, proprietary
information that is DESTACO property. Do
not disclose to or duplicate for others
except as authorized by DESTACO.

COMPONENT	Vertical Hold Down Clamps	
DIMENSIONS : [IN] MM	505-MLBLSC	REV
TOLERANCES : ±[0.020] 0.51		01/30/19
	500-SERIES	SHEET
		1 of 1