

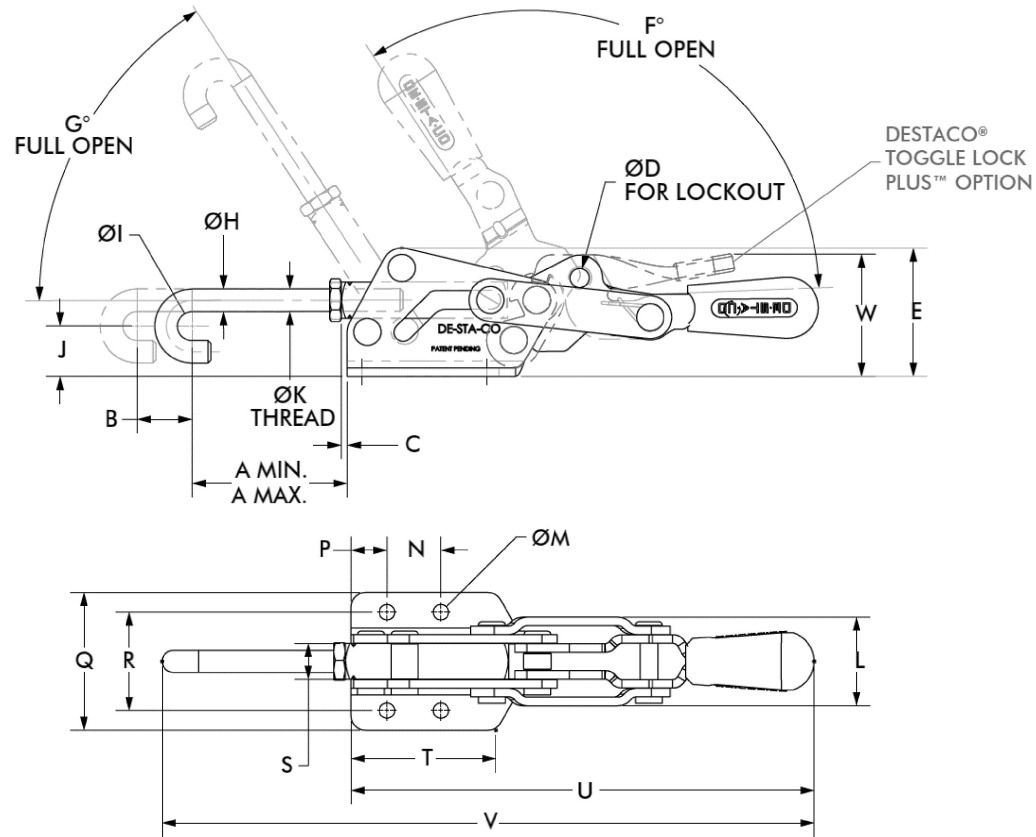

CLOSED POSITION

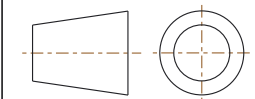

A MIN.	[1.99] 50,6	L	[1.24] 31,4
A MAX.	[2.50] 63,6	Ø M	[0.22] Ø5,5
B	[0.75] 19,1	N	[0.75] 19,1
C	[0.08] 2,1	P	[0.50] 12,7
Ø D	[0.27] Ø6,7	Q	[1.93] 49
E	[1.77] 44,9	R	[1.38] 35
F	123°	S	[0.50] 12,7
G	57°	T	[2.03] 51,5
Ø H	[0.31] Ø8,0	U	[6.47] 164,4
Ø I	[0.39] Ø10	V	[8.98] 228
J	[0.69] 17,6	W	-
K	M8x1.25	-	-



NOTES :

1. MAX. HOLDING CAPACITY : [1500lbf] 6700N
2. WEIGHT : [1.0lb] 0,50kg
3. DRAWING MOVEMENT : [0.75] 19,1
4. HOOK ADJUSTMENT RANGE : [0.55] 14
5. DIMENSIONS AND TOLERANCES SUBJECT TO CHANGE WITHOUT PRIOR NOTICE



15 Corporate Drive,
Auburn Hills, MI 48326, USA
Phone: 888-337-8226, Fax: 800-682-9689
www.destaco.com

This Drawing is the Property of DESTACO.
It contains confidential, proprietary
information that is DESTACO property. Do
not disclose to or duplicate for others
except as authorized by DESTACO.

COMPONENT

Pull Action Latch Clamps

DIMENSIONS : [IN] MM

3051-SS

REV

TOLERANCES : ±[0.020] 0.51

3051-SERIES

03/20/19

SHEET

1 of 1