

CLOSED POSITION

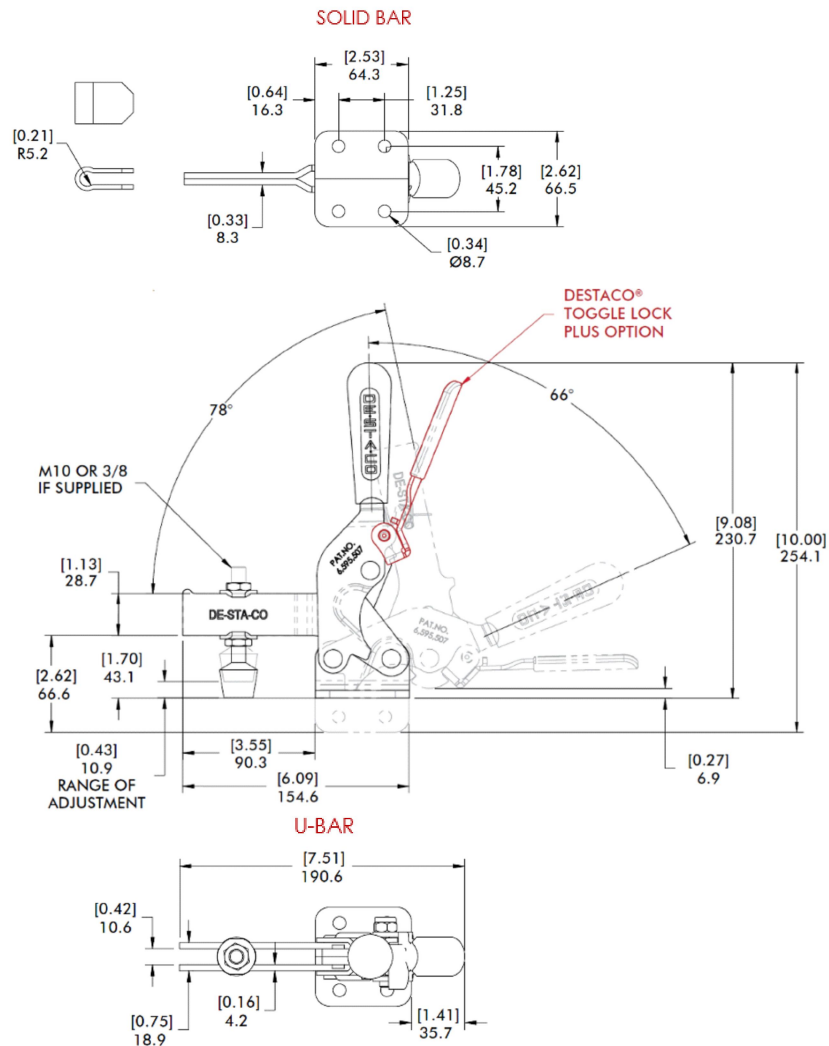

**NOTES :**

1. MAX. HOLDING CAPACITY : 6230 N [1400 lbf]
2. CLAMP BAR OPENING (+ 10°) : 78°
3. HANDLE OPENING (+ 10°) : 66°
4. WEIGHT : 1,16 kg [2.56 lbs]
5. DIMENSIONS AND TOLERANCES SUBJECT TO CHANGE WITHOUT PRIOR NOTICE

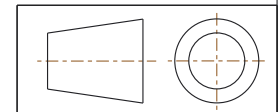

COMPONENT	Vertical Hold Down Clamps	
DIMENSIONS : [IN] MM	<b>2010-UBR</b>	REV
TOLERANCES : ±[0.020] 0.51		03/25/19
	<b>2010-SERIES</b>	SHEET
		1 of 1



15 Corporate Drive,  
Auburn Hills, MI 48326, USA  
Phone: 888-337-8226, Fax: 800-682-9689  
www.destaco.com

This Drawing is the Property of DESTACO.  
It contains confidential, proprietary information that is DESTACO property. Do not disclose to or duplicate for others except as authorized by DESTACO.