

Pneumatic Toggle Clamps

01/28/2025



info@cesehsa.com.mx

cesehsa.com.mx

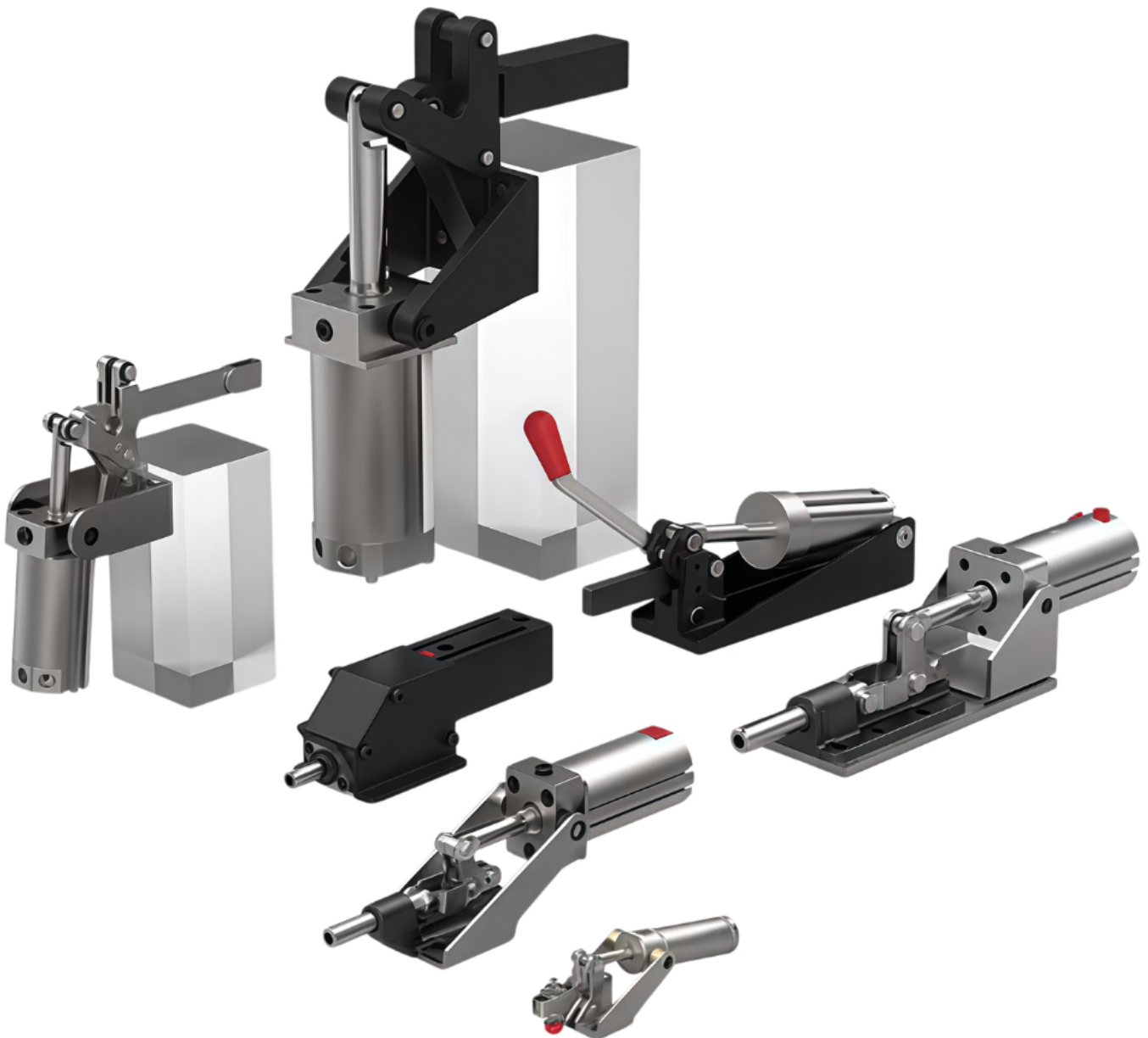

812 SERIES

Pneumatic Toggle Clamps | Product Overview

Features:

- Smallest of the pneumatic hold down series
- Pneumatic version of Model 201-U

Applications:

- Assembly
- Welding

Also Available:

See page MC-ACC-1
for spindle accessories

See page MC-PSC-38
for sensing options

High temperature version available
upon request as Model 812-**U-HT**

812-U



Technical Information | Holding Capacities

Model	Maximum Holding Capacity		Maximum Exerting Force @ 5 bar [72 PSI]		Weight	Bore Size	Air Consumption† dm ³ [ft ³]	Port Size	Accessories (Supplied)	
	Inner	Outer	Inner	Outer					Spindle Accessory	Flanged Washers
812-U	[100 lbf] 440 N	[55 lbf] 245 N	[136 lbf] 613 N	[92 lbf] 413 N	[0.46 lbs] 0,21 kg	[0.75] 19,1	[0.003] 0,09	M5	305208-M	102111

†Per double stroke at 5 bar [72 PSI]

Max. Operating Temp: -23°C to 74°C [-10°F to 165°F]

Optional Sensors: 810156, 810158

Replacement Clamp Assembly: 812-U-LC

Replacement Cylinder Assembly: 812CYL

In no case should the inlet pressure be high enough to create an exerting force that exceeds the clamp's holding capacity. See Technical Appendix Section for details.

812 SERIES

Pneumatic Toggle Clamps | Dimensions | -U

812-U

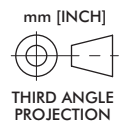
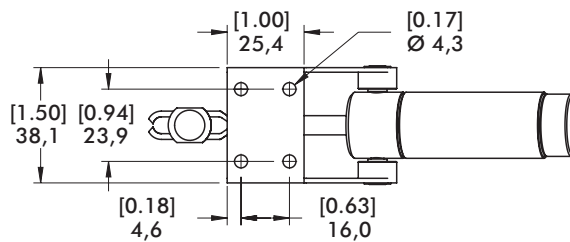
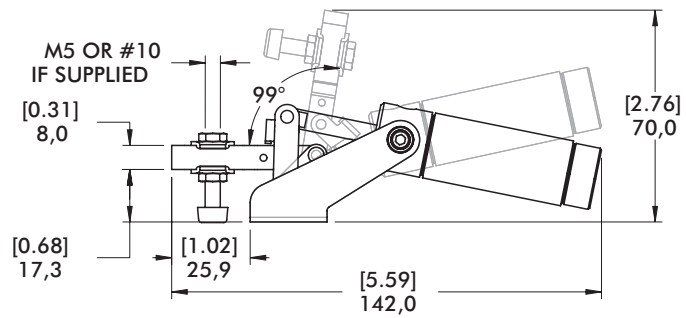
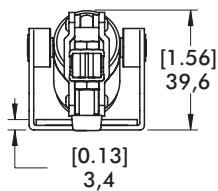
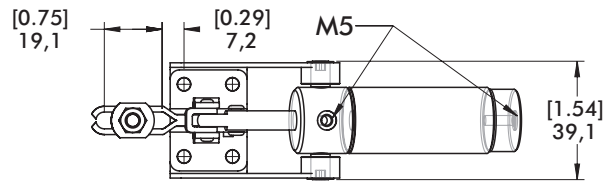

Note:

Model 812-U requires either 810156 or 810158 sensors. Two (2) sensors are required if detecting both open and closed positions. These sensors use 810156-1 (included with sensors) band clamp to mount the sensor to the cylinder wall.



802 SERIES

Pneumatic Toggle Clamps | Product Overview

Features:

- Pneumatic version of Model 202-U
- Sensor ready for T-slot or round sensors
- Optional handle version allows for manual operation during setup and positioning

Applications:

- Assembly
- Welding

Also Available:

See page MC-ACC-1 for spindle accessories
See page MC-PSC-38 for sensing options

802-U
802-UE

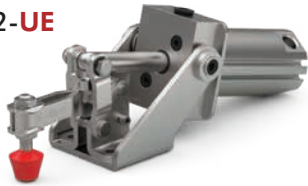

802-UH
802-UEH

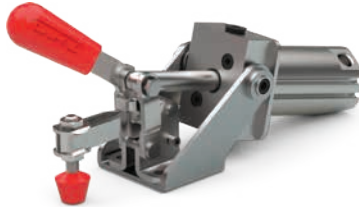

Technical Information | Holding Capacities

Model	Maximum Holding Capacity		Max. Exerting Force @ 5 bar [72 PSI]		Weight	Bore Size	Air Consumption† dm ³ [ft ³]	Port Size	Accessories (Supplied)	
	Inner	Outer	Inner	Outer					Spindle Accessory	Flanged Washers
802-U								1/8 NPT	202208-M	215105
802-UE	[200 lbf]	[110 lbf]	[200 lbf]	[110 lbf]	[1.52 lbs]	[0.79]	[0.0006]	G-1/8		
802-UH	890 N	490 N	890 N	490 N	0,69 kg	20	0,02	1/8 NPT		
802-UEH								G-1/8		

†Per double stroke at 5 bar [72 PSI]

Max Cylinder Pressure: 10bar [145psig]*

Max Operating Temp: -10°C to 90°C [-14°F to 194°F]

Replacement Seal Kit: 802550-20-1-00

Replacement Clamp Assembly: 802-U-LC

Replacement Cylinder Assembly: 802CYL

*In no case should the inlet pressure be high enough to create an exerting force that exceeds the clamp's holding capacity. See Technical Appendix for details.

Sensor Accessories

Round Reed Switch with Quick Disconnect

T-slot Reed Switch with Quick Disconnect

Quick Disconnect 2M Extension Cable

Quick Disconnect 5M Extension Cable

Item Number

810169

8EA-109-1

CABL-010

CABL-013

See Pneumatic Accessories section for more options

802 SERIES

Pneumatic Toggle Clamps | Dimensions | -U/-UE/-UH/-UEH

802-U
802-UE

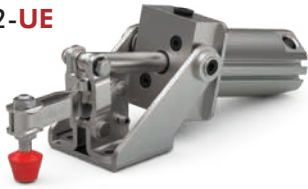

802-UH
802-UEH

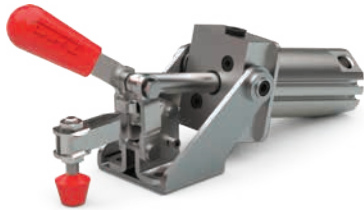

802-U / UH 1/8" NPT
802-UE / UEH G-1/8

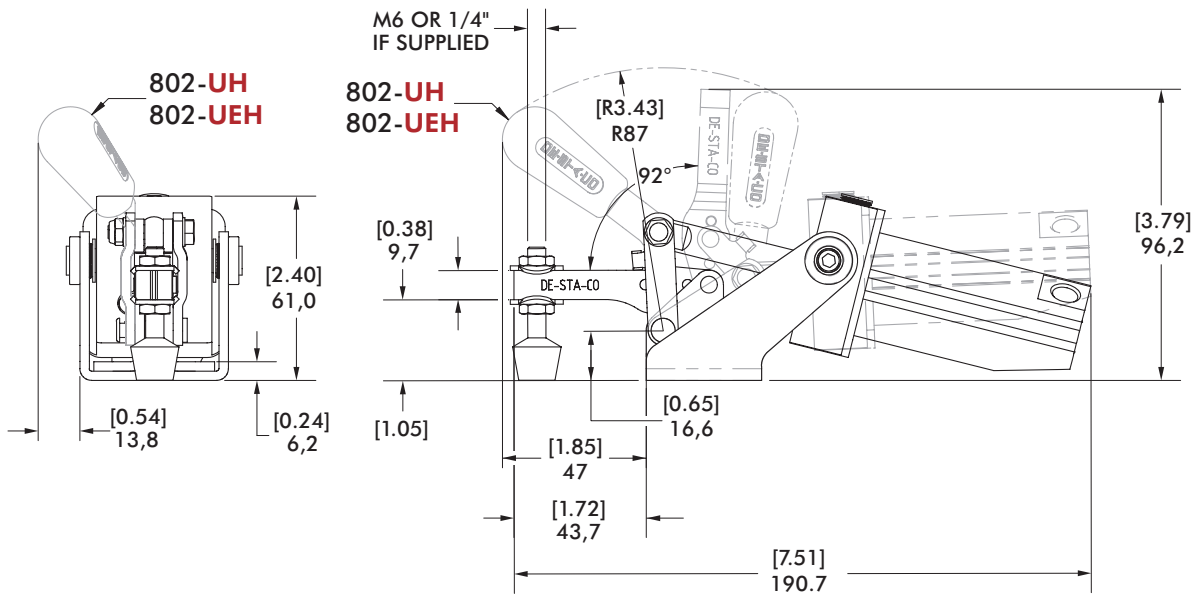
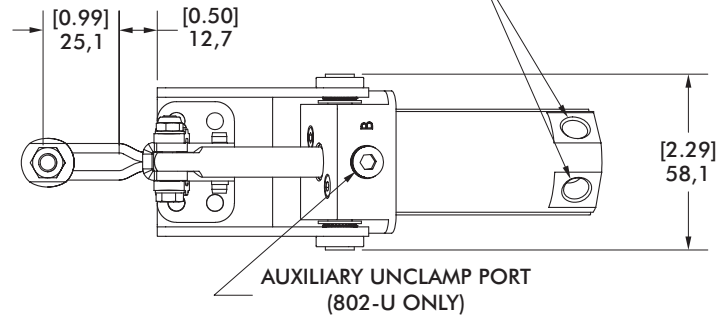

mm [INCH]
THIRD ANGLE PROJECTION

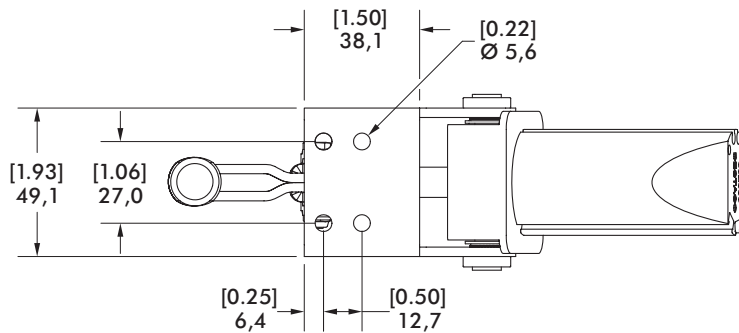

807 SERIES

Pneumatic Toggle Clamps | Product Overview

Features:

- Pneumatic version of Series 207 manual clamps
- Sensor ready for round or T-slot sensors.
- Built-in flow restriction eliminates need for external flow controls
- Optional handle version allows for manual operation during setup and positioning (U-bar only)

Applications:

- Assembly
- Welding

Also Available:

See page MC-ACC-1 for spindle accessories
See page MC-PSC-38 for sensing options

807-U
807-UE



807-UH
807-UEH



807-S
807-SE



Technical Information | Holding Capacities

Model	Maximum Holding Capacity		Maximum Exerting Force @ 5 bar [72 PSI]		Weight	Bore Size	Air Consumption [†] dm ³ [ft ³]	Port Size	Accessories (Supplied)		
	Inner	Outer	Inner	Outer					Spindle Accessory	Flanged Washers	Bolt Retainer
807-U								1/8 NPT			
807-UH	[375 lbf]	[275 lbf]	[576 lbf]	[297 lbf]				G-1/8	--	507107	--
807-UE	1670 N	1220 N	2573 N	1327 N	[1.66 lbs]	[1.26]	[0.015]		2007208-M		
807-UEH					0,75 kg	32	0,42				
807-S	[500 lbf]	[260 lbf]	[540 lbf]	[180 lbf]				1/8 NPT			207105
807-SE	2220 N	1160 N	2412 N	804 N				G-1/8	--	--	

[†]Per double stroke at 5 bar [72 PSI]

Max Cylinder Pressure: 10bar [145psig]*

Max Operating Temp: -10°C to 90°C [-14°F to 194°F]

Replacement Seal Kit: 802450-32-1-00

Replacement Clamp Assembly: 807-U-LC, 807-S-LC

Replacement Cylinder Assembly: 807CYL

*In no case should the inlet pressure be high enough to create an exerting force that exceeds the clamp's holding capacity. See Technical Appendix for details.

Sensor Accessories

	Item Number
Round Reed Switch with Quick Disconnect	810169
T-slot Reed Switch with Quick Disconnect	8EA-109-1
Quick Disconnect 2M Extension Cable	CABL-010
Quick Disconnect 5M Extension Cable	CABL-013

See Pneumatic Accessories section for more options

807 SERIES

Pneumatic Toggle Clamps | Dimensions | -U/-UE/-UH/-UEH/-S/-SE

807-U
807-UE



802-UH
802-UEH



807-U / 807-UH / 807-S 1/8" NPT
807-UE / 807-UEH / 807-SE G-1/8

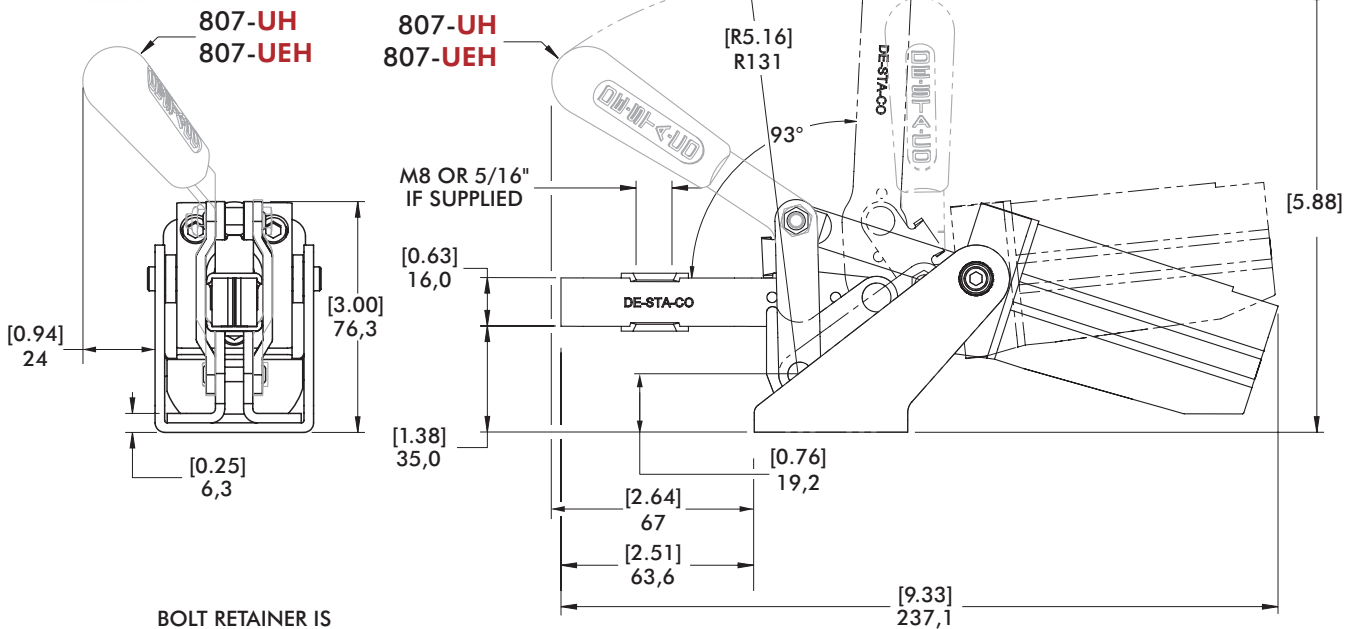
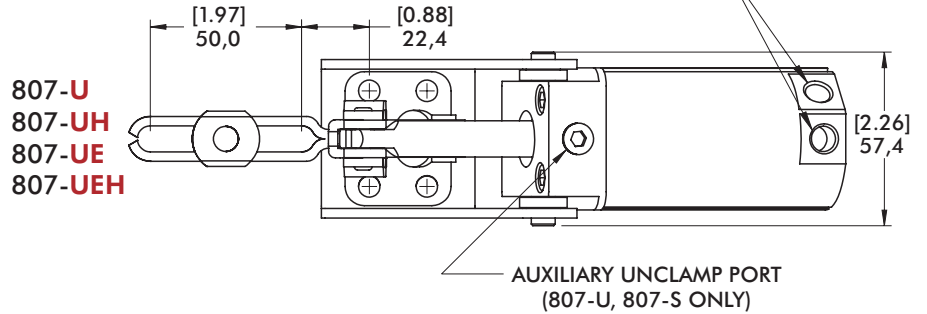

BOLT RETAINER IS SUPPLIED LOOSE AND NEEDS TO BE ATTACHED BY CUSTOMER

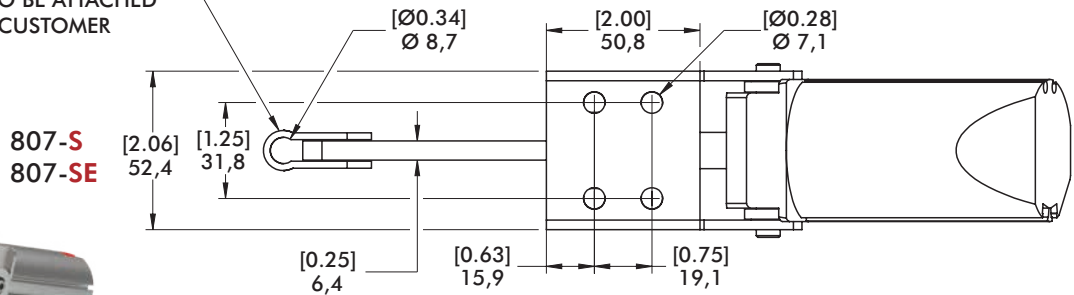

807-S
807-SE

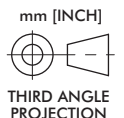

810 SERIES

Pneumatic Toggle Clamps | Product Overview

Features:

- Pneumatic version of Series 210 manual clamps
- Sensor ready for round or T-slot style sensors
- Built-in flow restriction eliminates need for external flow controls
- Optional handle version allows for manual operation during setup and positioning (U-bar only)

Applications:

- Assembly
- Welding

Also Available:

See page MC-ACC-1 for spindle accessories

See page MC-PSC-38 for sensing options

810-U
810-UE



810-UH
810-UEH



810-S
810-SE



Technical Information | Holding Capacities

Model	Maximum Holding Capacity		Maximum Exerting Force @ 5 bar [72 PSI]		Weight	Bore Size	Air Consumption† dm³ [ft³]	Port Size	Accessories (Supplied)		
	Inner	Outer	Inner	Outer					Spindle Accessory	Flanged Washers	Bolt Retainer
810-U								1/8 NPT	--		
810-UH	[600 lbf]	[290 lbf]	[856 lbf]							235106	--
810-UE	2670 N	1290 N	3834 N	[407 lbf]	[4.07 lbs]	[1.57]	[0.029]	G-1/8	240208-M		
810-UEH				1823 N	1,85 kg	40	0,83				
810-S	[750 lbf]	[500 lbf]	[702 lbf]					1/8 NPT	--	--	210114
810-SE	3340 N	2220 N	3143 N					G-1/8			

†Per double stroke at 5 bar [72 PSI]

Max Cylinder Pressure: 10bar [145psig]*

Max Operating Temp: -10°C to 90°C [-14°F to 194°F]

Replacement Seal Kit: 810450-40-1-00

Replacement Clamp Assembly: 810-U-LC, 810-S-LC

Replacement Cylinder Assembly: 810CYL

*In no case should the inlet pressure be high enough to create an exerting force that exceeds the clamp's holding capacity.

Sensor Accessories

	Item Number
Round Reed Switch with Quick Disconnect	810169
T-slot Reed Switch with Quick Disconnect	8EA-109-1
Quick Disconnect 2M Extension Cable	CABL-010
Quick Disconnect 5M Extension Cable	CABL-013

See Pneumatic Accessories section for more options

810 SERIES

Pneumatic Toggle Clamps | Dimensions | -U/-UE/-UH/-UEH/-S/-SE

810-U
810-UE



810-UH
810-UEH



810-U / 810-UH / 810-S 1/8" NPT
810-UE / 810-UEH / 810-SE G-1/8

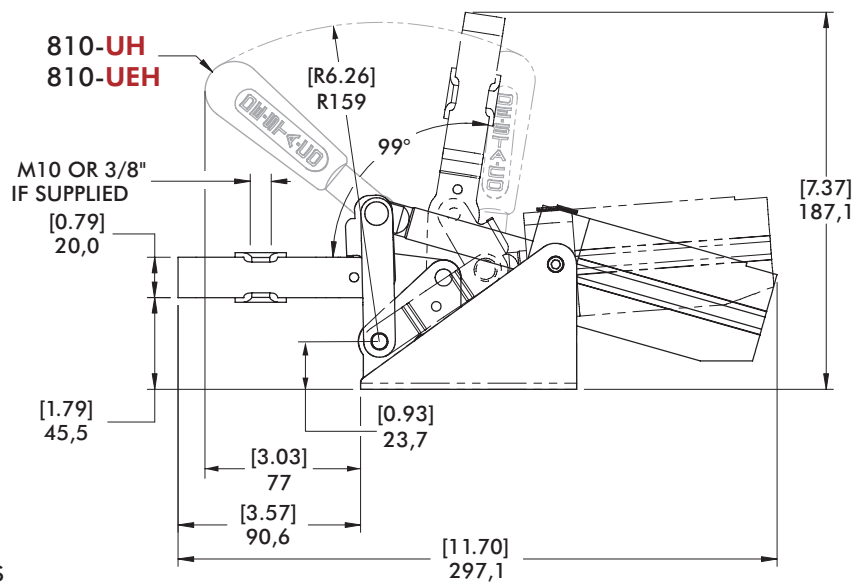
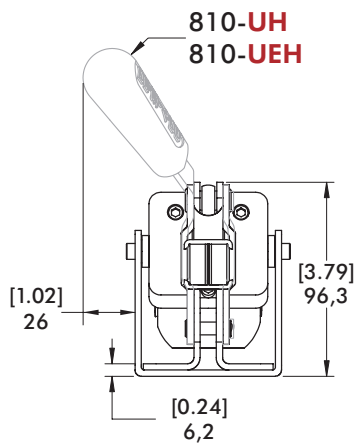
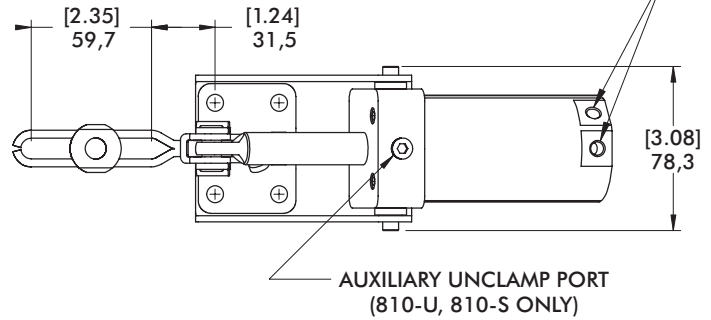

BOLT RETAINER IS SUPPLIED LOOSE AND NEEDS TO BE ATTACHED BY CUSTOMER

810-S
810-SE



810-S
810-SE

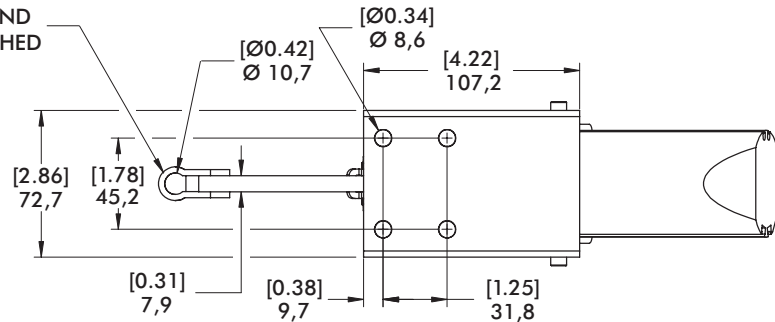

mm [INCH]
THIRD ANGLE PROJECTION

846 SERIES

Pneumatic Toggle Clamps | Product Overview

Features:

- Similar in size to 807 but with higher holding capacity
- Large, solid clamping arm is easily modified to suit application requirements
- Sensor ready for round or T-slot style sensors

Applications:

- Assembly
- Welding

Also Available:

See page MC-PSC-38 for sensing options

846 ⓘ



Technical Information | Holding Capacities

Model	Maximum Holding Capacity		Max. Exerting Force @ 5 bar [72 PSI]		Weight	Bore Size	Air Consumption† dm ³ [ft ³]	Port Size
	Inner	Outer	Inner	Outer				
846 ⓘ	[750 lbf] 3340 N	[520 lbf] 2310 N	[786 lbf] 3520 N	[491 lbf] 2200 N	[4.18 lbs] 1,90 kg	[1.57] 40	[0.029] 0,83	1/8 NPT

ⓘ This item is available upon request. †Per double stroke at 5 bar [72 PSI]

Max Cylinder Pressure: 10bar [145psig]*

Max Operating Temp: -10°C to 90°C [-14°F to 194°F]

Replacement Seal Kit: 810450-40-1-00

Replacement Clamp Assembly: 846-LC

Replacement Cylinder Assembly: 846CYL

*In no case should the inlet pressure be high enough to create an exerting force that exceeds the clamp's holding capacity. See Technical Appendix Section for details.

Sensor Accessories

	Item Number
Round Reed Switch with Quick Disconnect	810169
T-slot Reed Switch with Quick Disconnect	8EA-109-1
Quick Disconnect 2M Extension Cable	CABL-010
Quick Disconnect 5M Extension Cable	CABL-013

See Pneumatic Accessories section for more options

846 SERIES

Pneumatic Toggle Clamps | Dimensions

846 ①

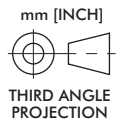
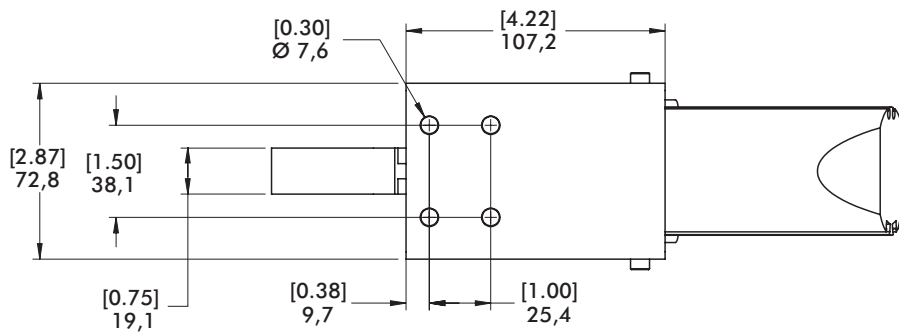
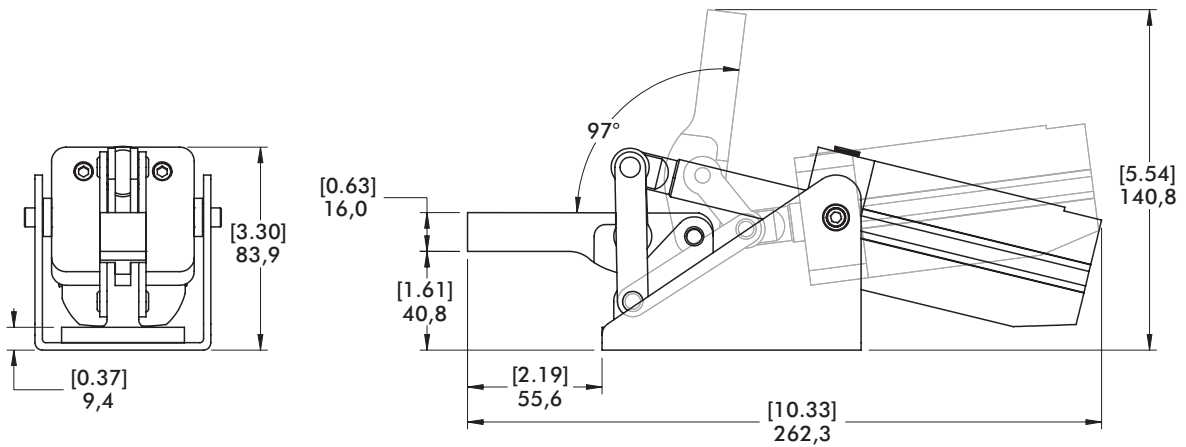
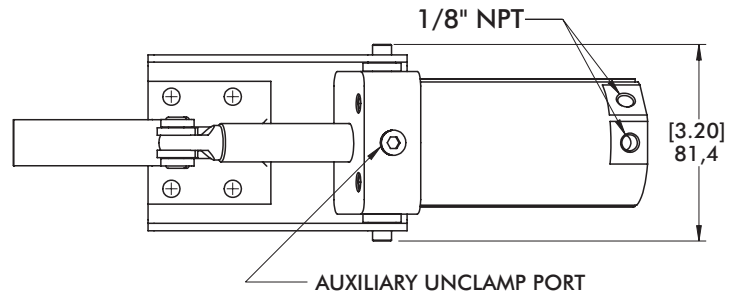

847 SERIES

Pneumatic Toggle Clamps | Product Overview

Features:

- Pneumatic version of Series 247 manual clamps
- Switch ready for Ø4mm or 6,5mmX5mm sensors
- Built-in flow restriction eliminates need for external flow controls

Applications:

- Assembly
- Welding

Also Available:

See page MC-ACC-1 for spindle accessories

See page MC-PSC-38 for sensing options

847-U



847-S



Technical Information | Holding Capacities

Model	Maximum Holding Capacity		Max. Exerting Force @ 5 bar [72 PSI]		Weight	Bore Size	Air Consumption† dm ³ [ft ³]	Port Size	Accessories (Supplied)		
	Inner	Outer	Inner	Outer					Spindle Accessory	Flanged Washers	Bolt Retainer
847-U	[1000 lbf] 4450 N	[480 lbf] 2135 N	[948 lbf] 4248 N	[450 lbf] 2018 N	[8.93 lbs] 4,05 kg	[1.97] 50	[0.044] 1,25	1/4 NPT	--	247109	--
847-S	[1000 lbf] 4450 N	[650 lbf] 2890 N		[426 lbf] 1912 N				1/4 NPT	--	--	247110

†Per double stroke at 5 bar [72 PSI]

Max Cylinder Pressure: 10bar [145psig]*

Max Operating Temp: -10°C to 90°C [-14°F to 194°F]

Replacement Seal Kit: 847450-50-1-00

Replacement Clamp Assembly: 847-U-LC, 847-S-LC

Replacement Cylinder Assembly: 847CYL

*In no case should the inlet pressure be high enough to create an exerting force that exceeds the clamp's holding capacity. See Technical Appendix Section for details.

Sensor Accessories

Round Reed Switch with Quick Disconnect

T-slot Reed Switch with Quick Disconnect

Quick Disconnect 2M Extension Cable

Quick Disconnect 5M Extension Cable

Item Number

810169

8EA-109-1

CABL-010

CABL-013

See Pneumatic Accessories section for more options

847 SERIES

Pneumatic Toggle Clamps | Dimensions | -U/-S

847-U

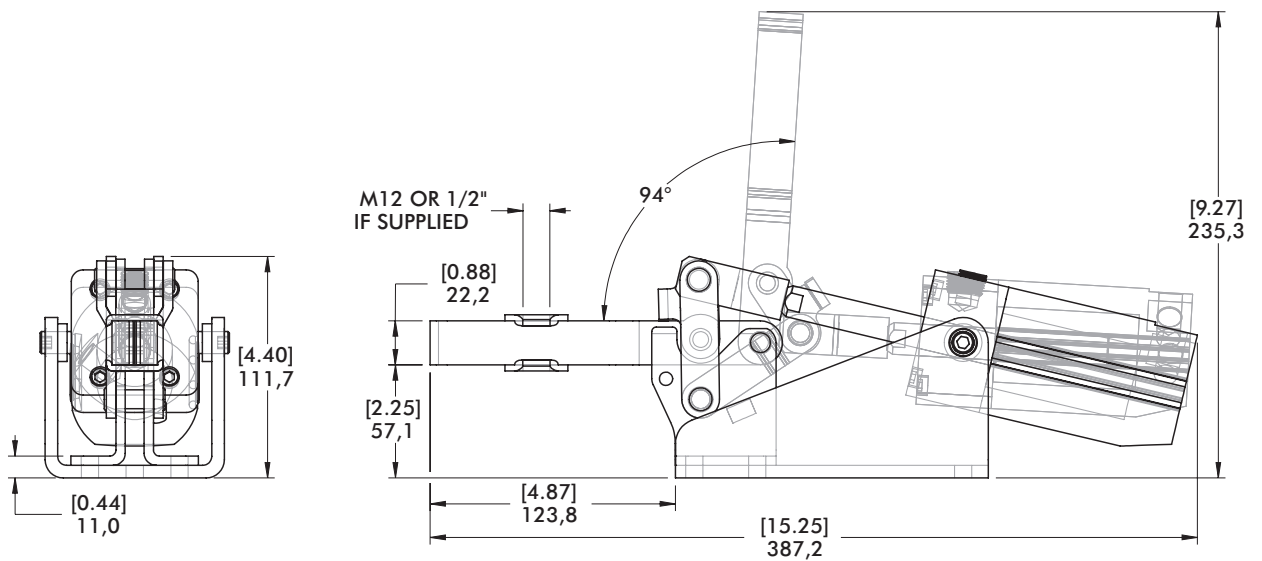
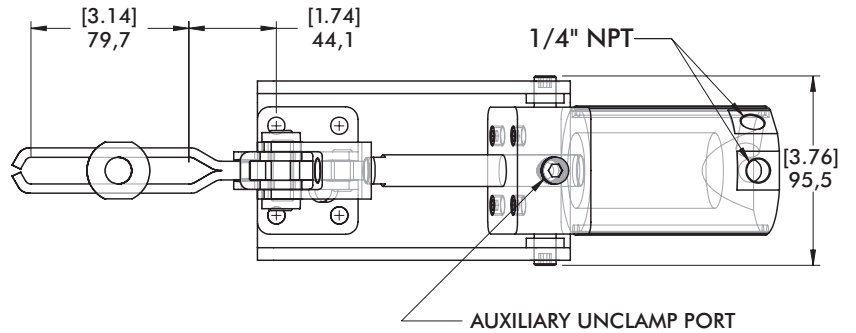

847-S

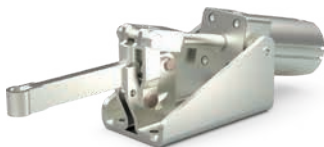

BOLT RETAINER IS SUPPLIED LOOSE AND NEEDS TO BE ATTACHED BY CUSTOMER

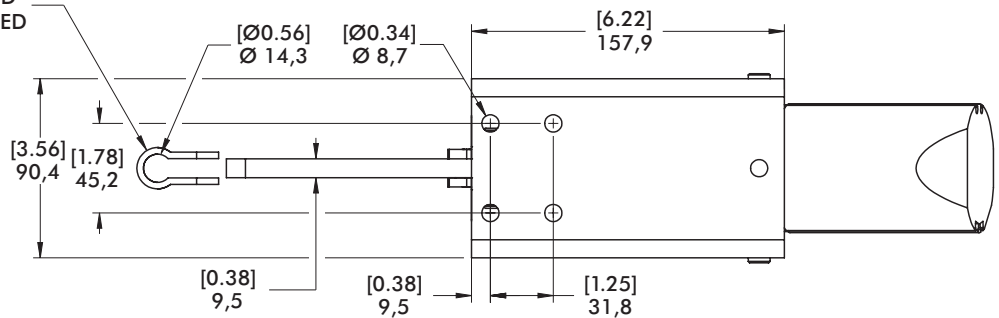

mm [INCH]
THIRD ANGLE PROJECTION

8007 SERIES

Pneumatic Toggle Clamps | Product Overview

Features:

- Hardened pins and bushing at all pivot points for long life cycle
- Solid clamping bar may be modified to suit application requirements
- Sensor ready for round or T-slot style sensors

Applications:

- Assembly
- Welding

Also Available:

See page MC-PSC-38 for sensing options

8007-E



8007-EHL



8007-EHR



Technical Information | Holding Capacities

Model	Maximum Holding Capacity		Max. Exerting Force @ 5 bar [72 PSI]		Weight	Bore Size	Air Consumption† dm ³ [ft ³]	Port Size
	Inner	Outer	Inner	Outer				
8007-E					1,6 kg [3.53 lbs]			
8007-EHL	[830 lbf] 3700 N	[405 lbf] 1800 N	[606 lbf] 2700 N	[225 lbf] 1000 N		[1.26] 32	[0.016] 0,44	G-1/8
8007-EHR					1,7 kg [3.75 lbs]			

†Per double stroke at 5 bar [72 PSI]

Max Cylinder Pressure: 10bar [145psig]*

Max Operating Temp: -10°C to 90°C [-14°F to 194°F]

Replacement Clamp Assembly: 8007-LC

*In no case should the inlet pressure be high enough to create an exerting force that exceeds the clamp's holding capacity. See Technical Appendix Section for details.

Sensor Accessories

Round Reed Switch with Quick Disconnect

T-slot Reed Switch with Quick Disconnect

Quick Disconnect 2M Extension Cable

Quick Disconnect 5M Extension Cable

Item Number

810169

8EA-109-1

CABL-010

CABL-013

See Pneumatic Accessories section for more options

8007 SERIES

Pneumatic Toggle Clamps | Dimensions | -E/-EHL/-EHR



8007-EHR

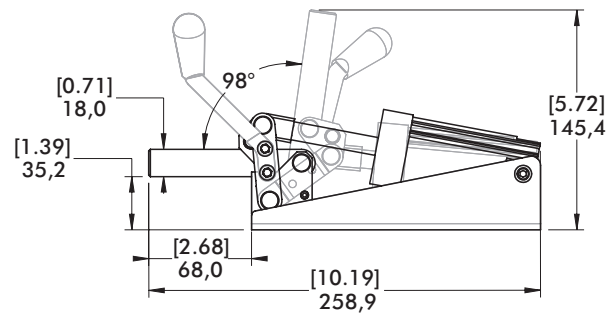
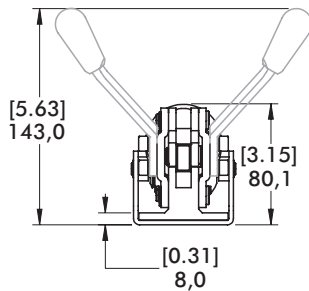
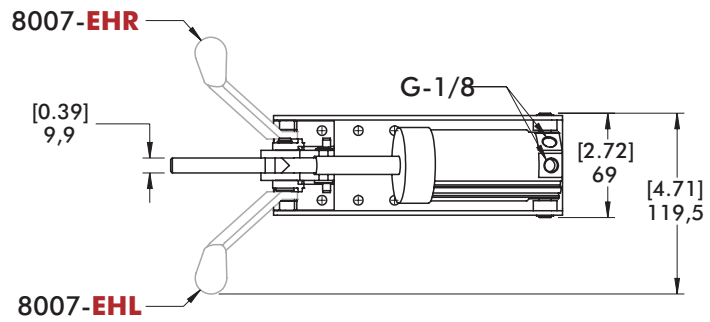

8007-E

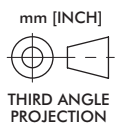
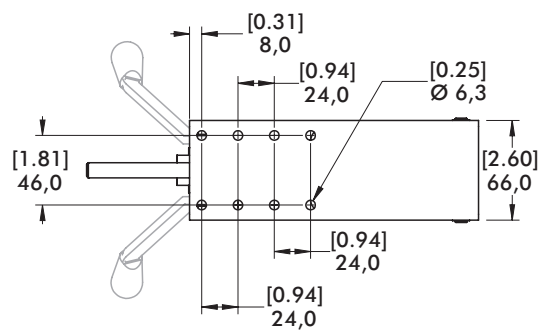

858 SERIES

Pneumatic Toggle Clamps | Product Overview

Features:

- Hardened pins and bushing at all pivot points for long lifecycle
- Large, solid clamping arm is easily modified to suit application requirements
- Sensor ready for round or T-slot style sensors

Applications:

- Assembly
- Welding

Also Available:

See page MC-PSC-38 for sensing options

858
858-E



Technical Information | Holding Capacities

Model	Maximum Holding Capacity		Max. Exerting Force @ 5 bar [72 PSI]		Weight	Bore Size	Air Consumption† dm ³ [ft ³]	Port Size
	Inner	Outer	Inner	Outer				
858	[4,000 lbf]	[2,000 lbf]	[1,530 lbf]	[800 lbf]	[16.11 lbs]	[2.48]	[0.109]	1/4 NPT
858-E	17800 N	8900 N	6857 N	3585 N	7.31 kg	63	3,08	G-1/4

†Per double stroke at 5 bar [72 PSI]

Max Cylinder Pressure: 10bar [145psig]*

Max Operating Temp: -10°C to 90°C [-14°F to 194°F]

Replacement Seal Kit: 850450-63-1-00

Replacement Clamp Assembly: 858-LC

Replacement Cylinder Assembly: 858CYL

*In no case should the inlet pressure be high enough to create an exerting force that exceeds the clamp's holding capacity. See Technical Appendix Section for details.

Sensor Accessories

Round Reed Switch with Quick Disconnect

T-slot Reed Switch with Quick Disconnect

Quick Disconnect 2M Extension Cable

Quick Disconnect 5M Extension Cable

Item Number

810169

8EA-109-1

CABL-010

CABL-013

See Pneumatic Accessories section for more options

858 SERIES

Pneumatic Toggle Clamps | Dimensions | -E

858
858-E

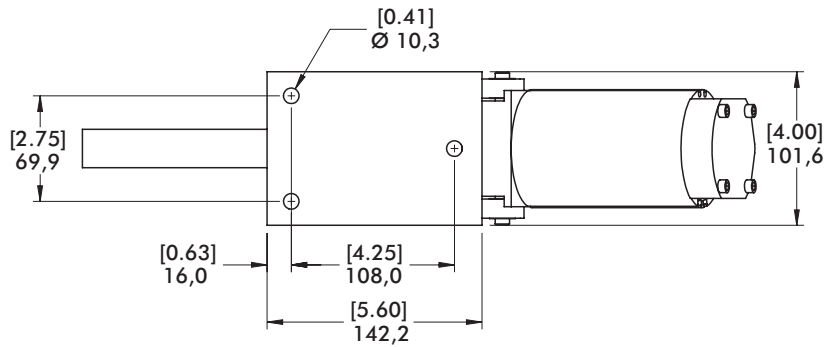
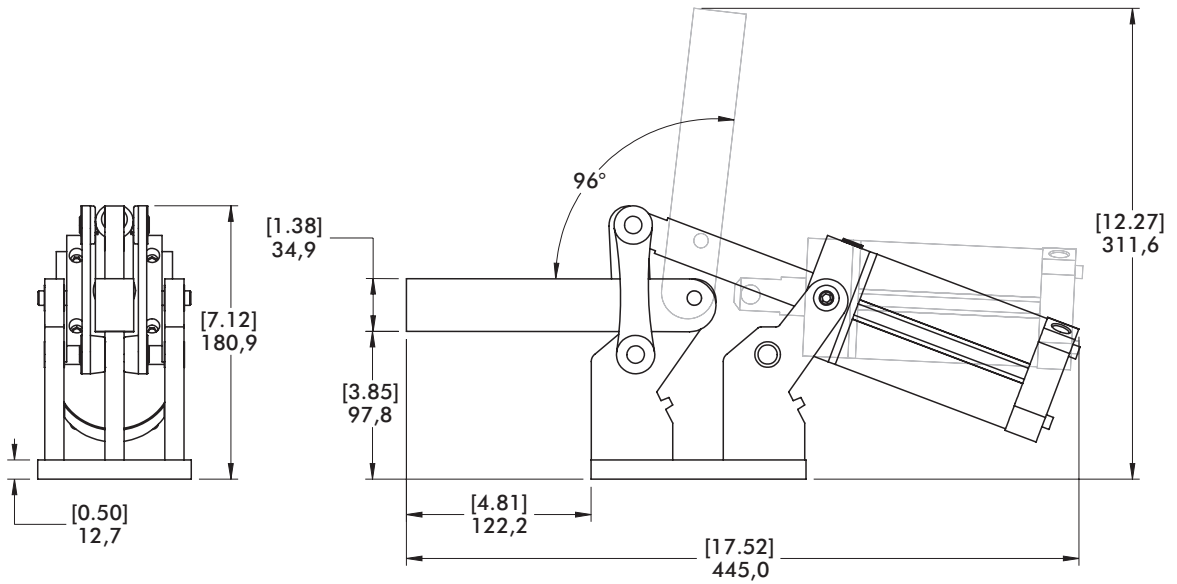
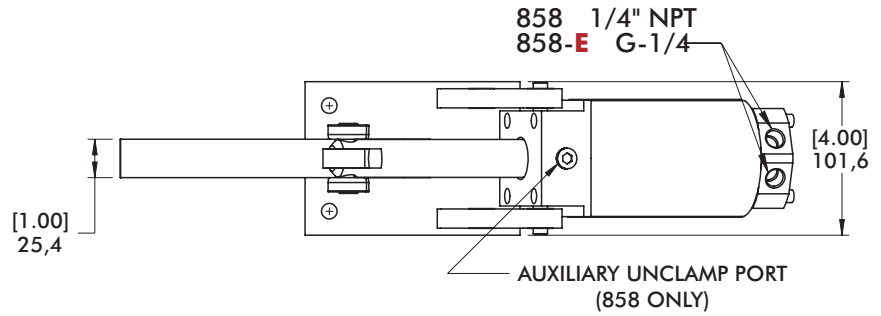

mm [INCH]
THIRD ANGLE
PROJECTION

8021, 8071 SERIES

Pneumatic Toggle Clamps | Product Overview

Features:

- Enclosed clamp for dirty environments such as spot and MIG welding
- Non-pivoting cylinder can be hard-piped into fixtures
- Sensor ready for round or T-slot style sensors

Applications:

- Assembly
- Welding

Also Available:

See page MC-ACC-1 for spindle accessories

See page MC-PSC-38 for sensing options

8021 ⓘ
8021-UE ⓘ



8071
8071-UE



Technical Information | Holding Capacities

Model	Maximum Holding Capacity		Max. Exerting Force @ 5 bar [72 PSI]		Weight	Bore Size	Air Consumption† dm ³ [ft ³]	Port Size	Accessories (Supplied)	
	Inner	Outer	Inner	Outer					Spindle Accessory	Flanged Washer
8021 ⓘ	[390 lbf]	[255 lbf]	[169 lbf]	[100 lbf]	[2.30 lbs]	[1.26]	[0.015]	1/8 NPT	--	8021122
8021-UE ⓘ	1735 N	1135 N	760 N	449 N	1,04 kg	32	0,42	G-1/8		
8071	[450 lbf]	[310 lbf]	[496 lbf]	[283 lbf]	[2.80 lbs]	[1.57]	[0.020]	1/8 NPT	--	507107
8071-UE	2000 N	1380 N	2218 N	1267 N	1,27 kg	40	0,58	G-1/8		

ⓘ This item is available upon request. †Per double stroke at 5 bar [72 PSI]

Max Cylinder Pressure: 10bar [145psig]*

Max Operating Temp: -10°C to 90°C [-14°F to 194°F]

Replacement Seal Kit: 8021: 802450-32-1-00

8071: 810450-40-1-00

*In no case should the inlet pressure be high enough to create an exerting force that exceeds the clamp's holding capacity. See Technical Appendix Section for details.

Sensor Accessories

	Item Number
Round Reed Switch with Quick Disconnect	810169
T-slot Reed Switch with Quick Disconnect	8EA-109-1
Quick Disconnect 2M Extension Cable	CABL-010
Quick Disconnect 5M Extension Cable	CABL-013

See Pneumatic Accessories section for more options

8021, 8071 SERIES

Pneumatic Toggle Clamps | Dimensions | -UE

8021
8021-UE

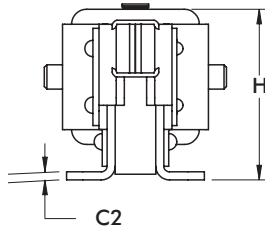

8071
8071-UE

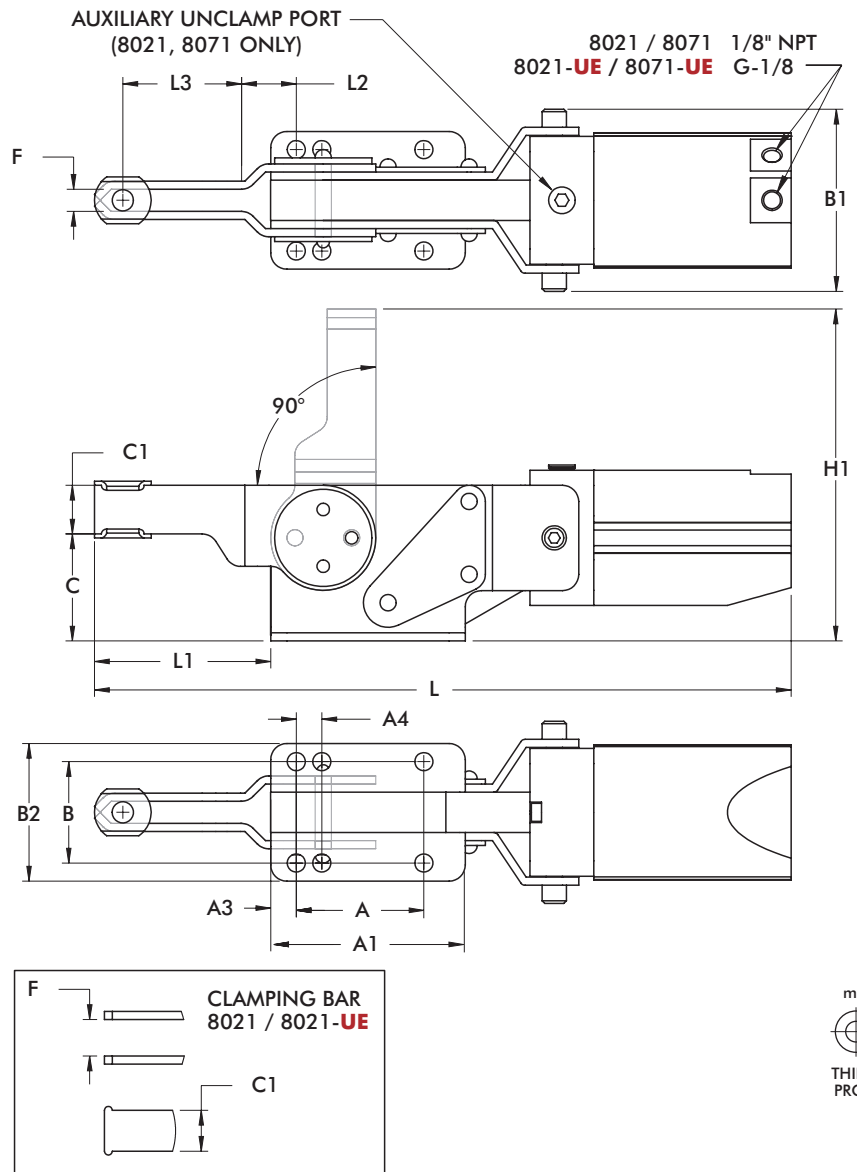

Model	A	A1	A3	A4	B	B1	B2	C	C1	C2	ØD	F
8021	[0.79]	[1.97]	[0.47]	-	[1.50]	[2.26]	[1.88]	[1.56]	[0.63]	[0.13]	[0.21]	[0.56]
8021-UE	20	50	12	-	38,2	57,4	47,9	39,6	16	3,2	5,3	14,3
8071	[1.97]	[3.00]	[0.39]	[0.39]	[1.56]	[2.81]	[2.12]	[1.65]	[0.75]	[0.13]	[0.28]	[0.34]
8071-UE	50	76,2	10	10	39,7	71,4	53,9	41,9	19,1	3,2	7,1	8,7

Model	H	H1	L	L1	L2	L3	M
8021	[2.40]	[4.44]	[9.86]	[2.25]	[0.44]	[1.31]	1/4
8021-UE	60,9	112,8	250,4	57,2	11	33,2	M6
8071	[2.63]	[5.12]	[10.74]	[2.72]	[0.40]	[1.83]	5/16
8071-UE	66,9	130	272,9	69	10,1	46,5	M8

817, 827 SERIES

Pneumatic Toggle Clamps | Product Overview

Features:

- Dual mounting surfaces for maximum flexibility
- Sensor ready for round or T-slot style sensors
- Built-in flow restriction eliminates need for external flow controls

Applications:

- Assembly
- Welding

Also Available:

See page MC-ACC-1 for spindle accessories

See page MC-PSC-38 for sensing options

817-U
817-UE



817-S
817-SE



827-U
827-UE



827-S
827-SE



Technical Information | Holding Capacities

Model	Maximum Holding Capacity		Max. Exerting Force @ 5 bar [72 PSI]		Weight	Bore Size	Air Consumption† dm ³ [ft ³]	Port Size	Accessories (Supplied)		
	Inner	Outer	Inner	Outer					Spindle Accessory	Flanged Washers	Bolt Retainer
817-U	[375 lbf] 1670 N		[369 lbf] 1648 N					1/8NPT	--	507107	--
817-UE		[200 lbf] 890 N		[225 lbf] 1005 N	1,05 kg [2.31 lbs]	[1.26] 32	[0.015] 0,42	G-1/8	225208-M		
817-S	[450 lbf] 2000 N		[360 lbf] 1608 N					1/8 NPT	--	--	207107
817-SE								G-1/8			
827-U	[600 lbf] 2670 N	[390 lbf] 1735 N		[309 lbf] 1383 N				1/8 NPT	--	235106	--
827-UE			[491 lbf] 2200 N		2,14 kg [4.71 lbs]	[1.57] 40	[0.029] 0,83	G-1/8	240208-M		
827-S	[700 lbf] 3110 N	[330 lbf] 1470 N		[281 lbf] 1257 N				1/8 NPT	--	--	210114
827-SE								G-1/8			

†Per double stroke at 5 bar [72 PSI]

Max Cylinder Pressure: 10bar [145psig]*

Max Operating Temp: -10°C to 90°C [-14°F to 194°F]

Replacement Seal Kit: 817: 802450-32-1-00
827: 810450-40-1-00

Replacement Clamp Assembly: 817-U-LC, 817-S-LC, 827-U-LC, 827-S-LC

Replacement Cylinder Assembly: 817: 807CYL, 827: 810CYL

*In no case should the inlet pressure be high enough to create an exerting force that exceeds the clamp's holding capacity. See Technical Appendix Section for details.

Sensor Accessories

	Item Number
Round Reed Switch with Quick Disconnect	810169
T-slot Reed Switch with Quick Disconnect	8EA-109-1
Quick Disconnect 2M Extension Cable	CABL-010
Quick Disconnect 5M Extension Cable	CABL-013

See Pneumatic Accessories section for more options

817, 827 SERIES

Pneumatic Toggle Clamps | Dimensions | -U/-UE/-S/-SE

817-U
817-UE



817-U / 817-S / 827-U / 827-S 1/8" NPT
817-UE / 817-SE / 827-UE / 827-SE G-1/8

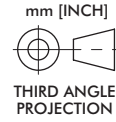
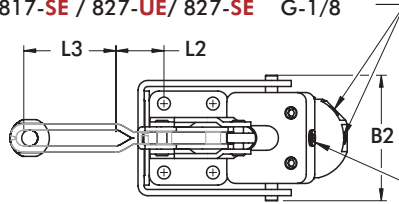

AUXILIARY UNCLAMP PORT
(817-U, 817-S, 827-U, 827-S ONLY)

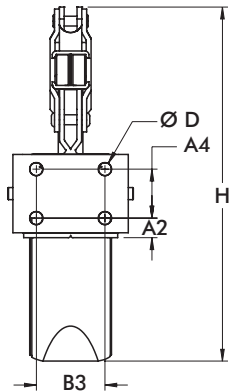

BOLT RETAINER IS SUPPLIED LOOSE AND NEEDS TO BE ATTACHED BY CUSTOMER

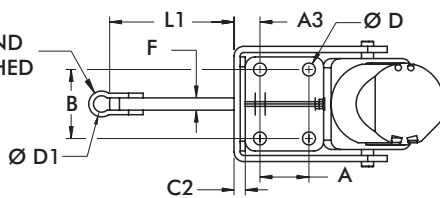
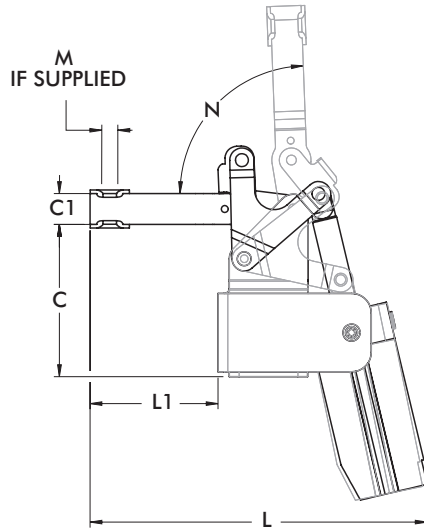

Mounting Options:

Use two bolts in the "side" mounting holes, to secure mounting bracket, when "top" mounting.

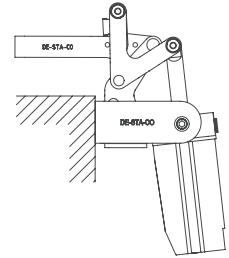
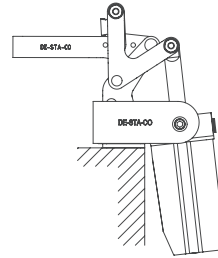
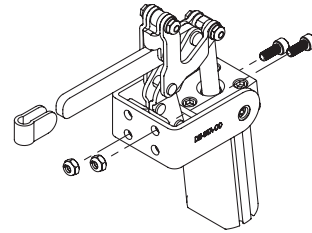

Top Mounting

Side Mounting

Model	A	A2	A3	A4	B	B2	B3	C	C1	C2	C3	C4
817-U												
817-UE	[0.63]	[0.44]	[0.60]	[0.63]	[1.00]	[2.44]	[1.00]	[2.69]	[0.63]	[0.12]	[1.25]	[1.31]
817-S	16	11,2	15,1	16	25,4	62	25,4	68,3	16	3,1	31,8	33,3
817-SE												
827-U								[3.89]	[0.79]			[1.76]
827-UE	[1.25]	[0.51]	[0.66]	[1.25]	[1.75]	[3.08]	[1.75]	98,8	20	[0.12]	[2.00]	44,8
827-S	31,8	12,8	16,8	31,8	44,45	78,3	44,45	[3.91]	[0.75]	3,1	50,8	[1.78]
827-SE								99,2	19,1			45,3

Model	ØD	ØD1	F	H	L	L1	L2	L3	M	N
817-U					[6.24]	[2.37]	[0.19]	[1.90]		
817-UE	[0.27]	-	-	[7.51]	158,6	60,3	4,8	48,4	5/16	90°
817-S	6,7	[0.34]	[0.25]	190,7	[6.97]	[3.04]	-	-	M8	
817-SE		8,7	6,4		175,5	77,2				
827-U					[8.61]	[3.27]	[1.23]	[2.35]		
827-UE	[0.33]	-	-	[9.04]	218,7	83,1	31,2	59,7	3/8	88°
827-S	8,4	[0.42]	[0.31]	229,7	[8.49]	[3.18]	-	-	M10	
827-SE		10,7	7,9		215,6	80,7				

868 SERIES

Pneumatic Toggle Clamps | Product Overview

Features:

- Hardened pins and bushing at all pivot points for long lifecycle
- Large, solid clamping arm is easily modified to suit application requirements
- Sensor ready for round or T-slot style sensors

Applications:

- Assembly
- Welding

Also Available:

See page MC-PSC-38 for sensing options

868
868-E



Technical Information | Holding Capacities

Model	Maximum Holding Capacity		Max. Exerting Force @ 5 bar [72 PSI]		Weight	Bore Size	Air Consumption† dm ³ [ft ³]	Port Size
	Inner	Outer	Inner	Outer				
868	[4000 lbf] 17800 N	[2400 lbf] 10675 N	[1704 lbf] 7637 N	[800 lbf] 3585 N	[17.0 lbs] 7,71 kg	[2.48] 63	[0.109] 3,08	1/4 NPT
868-E								G-1/4

†Per double stroke at 5 bar [72 PSI]

Max Cylinder Pressure: 10bar [145psig]*

Max Operating Temp: -10°C to 90°C [-14°F to 194°F]

Replacement Seal Kit: 850450-63-1-00

Replacement Clamp Assembly: 868-LC

Replacement Cylinder Assembly: 868CYL

*In no case should the inlet pressure be high enough to create an exerting force that exceeds the clamp's holding capacity. See Technical Appendix Section for details.

Sensor Accessories

	Item Number
Round Reed Switch with Quick Disconnect	810169
T-slot Reed Switch with Quick Disconnect	8EA-109-1
Quick Disconnect 2M Extension Cable	CABL-010
Quick Disconnect 5M Extension Cable	CABL-013

See Pneumatic Accessories section for more options

868 SERIES

Pneumatic Toggle Clamps | Dimensions | -E

868
868-E

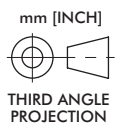
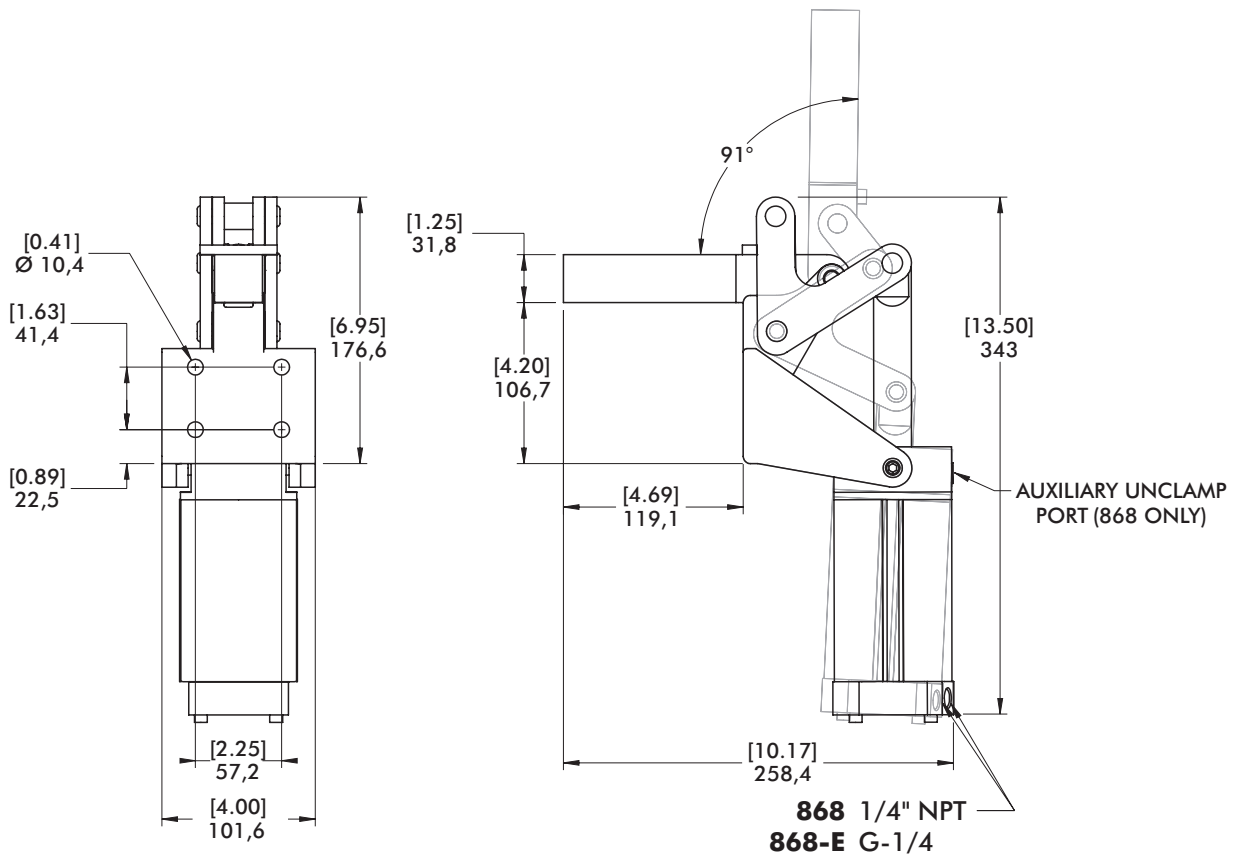
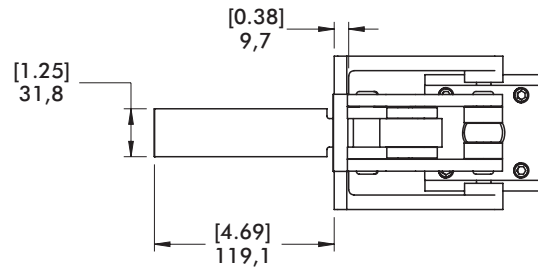

803 SERIES

Pneumatic Toggle Clamps | Product Overview

Features:

- Pneumatic version of Model 603 manual straight line action clamp
- Sensor ready for round or T-slot style sensors

Applications:

- Assembly
- Welding

Also Available:

See page MC-ACC-1 for spindle accessories

See page MC-PSC-38 for sensing options

High temperature version available
Upon Request, add **-HT** to model number. Example: 803-U-**HT**

803
803-ME



Technical Information | Holding Capacities | Dimensions | -ME

Model	Maximum Holding Capacity	Maximum Exerting Force @ 5 bar [72 PSI]	Plunger Travel	Plunger Thread	Weight	Bore Size	Air Consumption† dm³ [ft³]	Port Size
803	[600 lbf] 2670 N	[675 lbf] 3015 N	[0.75] 19,1	5/16-18	[1.86 lbs] 0,84 kg	[1.26] 32	[0.015] 0,42	1/8 NPT
803-ME				M8				G-1/8

†Per double stroke at 5 bar [72 PSI]

Max Cylinder Pressure: 10bar [145psig]

Max Operating Temp: -10°C to 90°C [-14°F to 194°F]

Replacement Seal Kit: 802450-32-1-00

Replacement Clamp Assembly: 803-LC, 803-M-LC

Replacement Cylinder Assembly: 807CYL

*In no case should the inlet pressure be high enough to create an exerting force that exceeds the clamp's holding capacity. See Technical Appendix Section for details.

Sensor Accessories

Round Reed Switch with Qk Disconnect

Item Number

810169

T-slot Reed Switch with Qk Disconnect

8EA-109-1

Quick Disconnect 2M Extension Cable

CABL-010

Quick Disconnect 5M Extension Cable

CABL-013

See Pneumatic Accessories section for more options

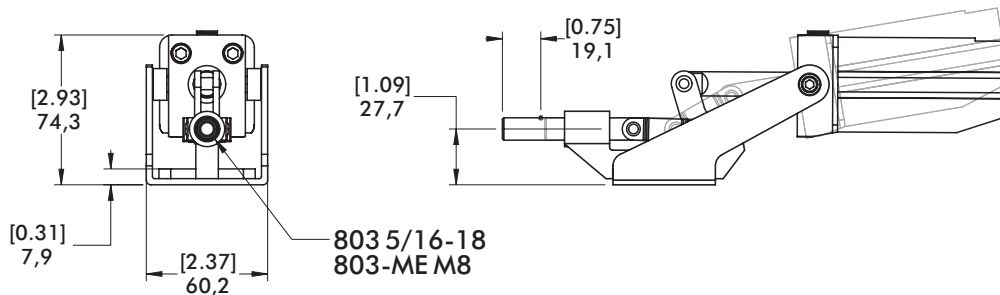
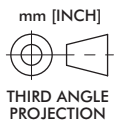
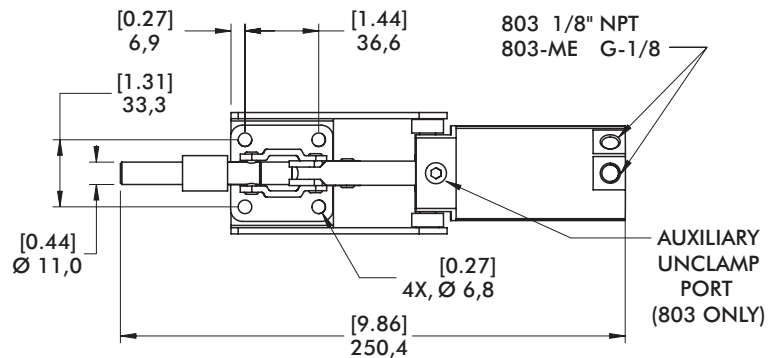

8031 SERIES

Pneumatic Toggle Clamps | Product Overview

Features:

- Fully enclosed straight line action clamp for the dirtiest environments
- Compact design with high holding capacity
- Sensor ready for round style sensors

Applications:

- Assembly
- Welding

Also Available:

See page MC-ACC-1 for spindle accessories

See page MC-PSC-38 for sensing options

8031 ⓘ



Technical Information | Holding Capacities | Dimensions

Model	Maximum Holding Capacity	Maximum Exerting Force @ 5 bar [72 PSI]	Plunger Travel	Plunger Thread	Weight	Bore Size	Air Consumption† dm³ [ft³]	Port Size
8031 ⓘ	[2000 lbf] 8900 N	[731 lbf] 3285 N	[0.75] 19,1	M8	[1.17 lbs] 2,58 kg	[1.26] 32	[0.006] 0,18	1/8 NPT

Max Cylinder Pressure: 10bar [145psig]*

Max Operating Temp: -10°C to 90°C [-14°F to 194°F]

*In no case should the inlet pressure be high enough to create an exerting force that exceeds the clamp's holding capacity. See Technical Appendix Section for details.

Sensor Accessories

	Item Number
Round Reed Switch with Quick Disconnect	810169
Quick Disconnect 2M Extension Cable	CABL-010
Quick Disconnect 5M Extension Cable	CABL-013

See Pneumatic Accessories section for more options

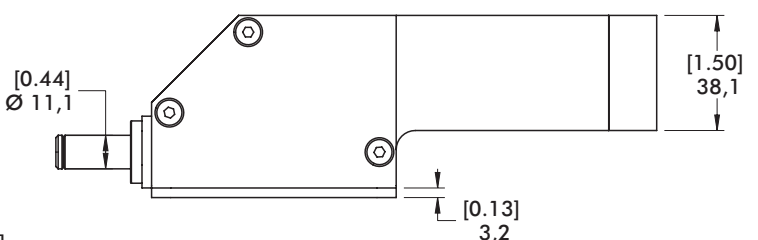
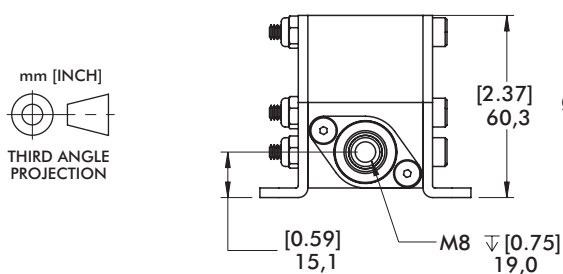
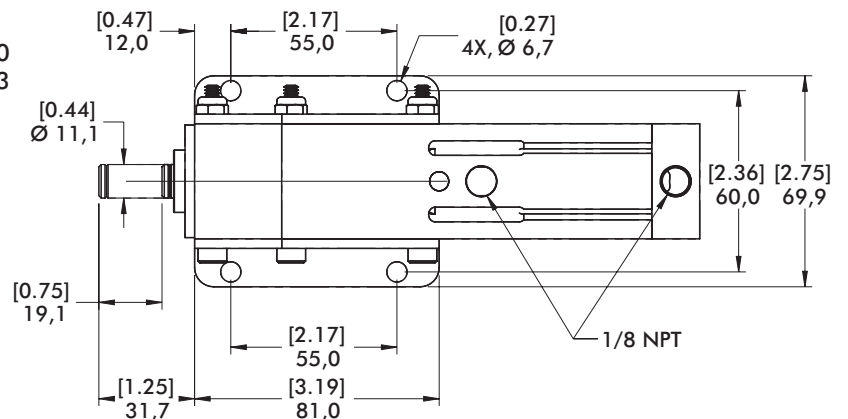

830 SERIES

Pneumatic Toggle Clamps | Product Overview

Features:

- Pneumatic version of Model 630 manual straight line action clamp
- Sensor ready for round or T-slot style sensors
- Built-in flow restriction eliminates need for external flow controls

Applications:

- Assembly
- Welding

Also Available:

See page MC-ACC-1 for spindle accessories

See page MC-PSC-38 for sensing options

830
830-ME



Technical Information | Holding Capacities | Dimensions | -ME

Model	Maximum Holding Capacity	Maximum Exerting Force @ 5 bar [72 PSI]	Plunger Travel	Plunger Thread	Weight	Bore Size	Air Consumption† dm³ [ft³]	Port Size
830	[2500 lbf] 11100 N	[800 lbf] 3582 N	[0.75] 19,1	3/8-16	2,79 kg [6.14 lbs]	[1.57] 40	[0.029] 0,83	1/8 NPT
830-ME				M10				G-1/8

†Per double stroke at 5 bar [72 PSI]

Max Cylinder Pressure: 10bar [145psig]
Max Operating Temp: -10°C to 90°C [-14°F to 194°F]
Replacement Seal Kit: 810450-40-1-00
Replacement Clamp Assembly: 830-LC, 830-M-LC
Replacement Cylinder Assembly: 810CYL

*In no case should the inlet pressure be high enough to create an exerting force that exceeds the clamp's holding capacity. See Technical Appendix Section for details.

Sensor Accessories

Round Reed Switch with Quick Disconnect
 T-slot Reed Switch with Quick Disconnect
 Quick Disconnect 2M Extension Cable
 Quick Disconnect 5M Extension Cable

Item Number

810169
 8EA-109-1
 CABL-010
 CABL-013

See Pneumatic Accessories section for more options

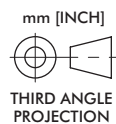
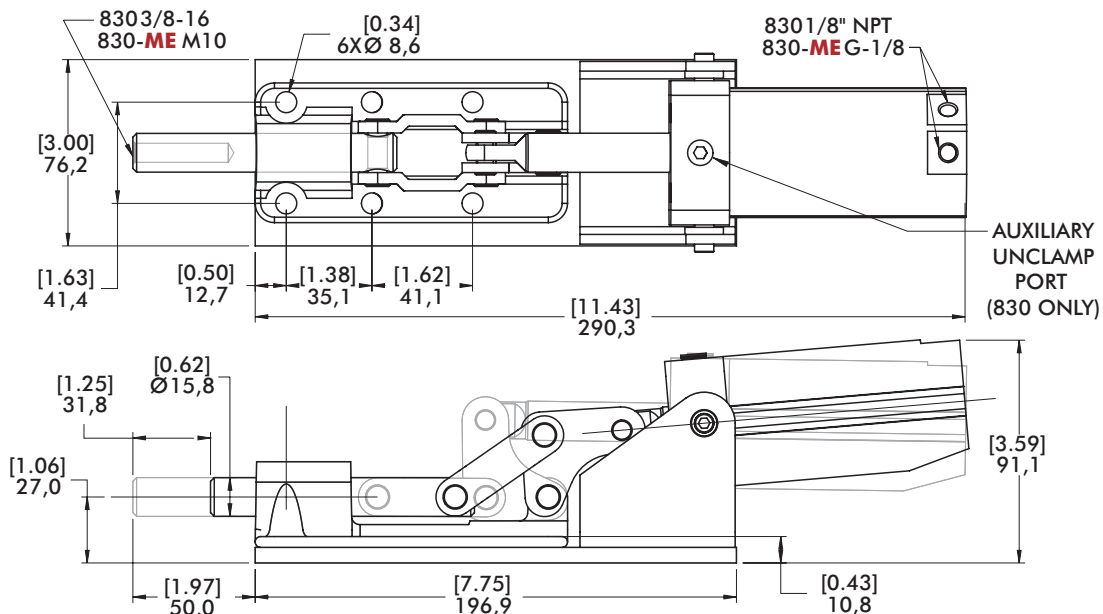

Features:

- Pneumatic version of Model 650 manual straight line action clamp
- Sensor ready for round or T-slot style sensors
- Built-in flow restriction eliminates need for external flow controls

Applications:

- Assembly
- Welding
- Light press operations

Also Available:

See page MC-ACC-1 for spindle accessories
See page MC-PSC-38 for sensing options

850 ⓘ
850-ME ⓘ

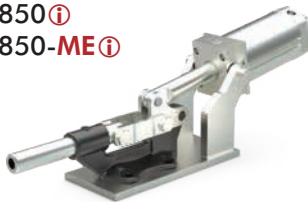

Technical Information | Holding Capacities | Dimensions | -ME

Model	Maximum Holding Capacity	Maximum Exerting Force @ 5 bar [72 PSI]	Plunger Travel	Plunger Thread	Weight	Bore Size	Air Consumption† dm³ [ft³]	Port Size
850 ⓘ	[16000 lbf] 71200 N	[1232 lbf] 5522 N	[2.00] 50,8	5/8-11	[16.66 lbs] 7,56 kg	[2.48] 63	[0.109] 3,08	1/4 NPT
850-ME ⓘ				M16				G-1/4

ⓘ This item is available upon request. †Per double stroke at 5 bar [72 PSI]

Max Cylinder Pressure: 10bar [145psig]
Max Operating Temp: -10°C to 90°C [-14°F to 194°F]
Replacement Seal Kit: 850450-63-1-00
Replacement Clamp Assembly: 850-LC, 850-M-LC
Replacement Cylinder Assembly: 868CYL

*In no case should the inlet pressure be high enough to create an exerting force that exceeds the clamp's holding capacity. See Technical Appendix Section for details.

Sensor Accessories

Round Reed Switch with Quick Disconnect
T-slot Reed Switch with Quick Disconnect
Quick Disconnect 2M Extension Cable
Quick Disconnect 5M Extension Cable

Item Number

810169
8EA-109-1
CABL-010
CABL-013

See Pneumatic Accessories section for more options

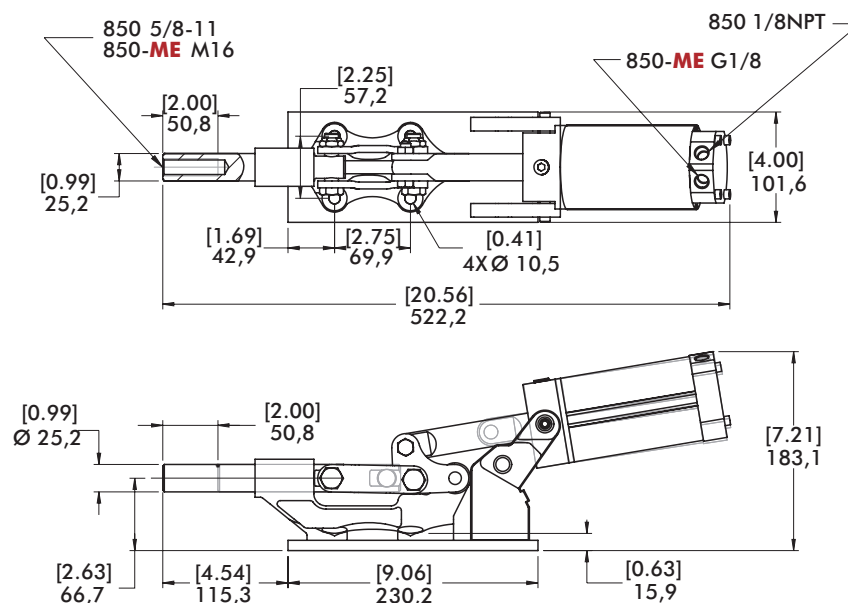

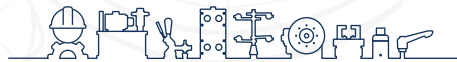

inf @ /CESEHSA.com.mx

