



Alfa Laval AlfaNova 66

Fusion-bonded plate heat exchanger in 100% stainless steel

Introduction

Alfa Laval AlfaNova fusion-bonded plate heat exchangers are made of 100% stainless steel. They are suitable for applications which place high demand on cleanliness, applications where aggressive media like ammonia are used or where copper and nickel contamination is unacceptable.

AlfaNova provides efficient heat transfer with a small footprint, has an extreme pressure fatigue resistance and covers high temperatures, up to 550°C/1022°F.

Applications

Suitable for a wide range of applications, such as:

- HVAC heating and cooling
- Refrigeration
- Oil cooling
- Industrial heating and cooling
- Process heating and cooling

Benefits

- Compact
- Easy to install
- Self-cleaning
- Low level of service and maintenance is required
- All units are pressure and leak tested
- Gasket free
- Copper free

Branded Features



AlfaNova

100% stainless steel



PressureSecure

Unparalleled strength for demanding duties



REFuture

A future-proof investment for tomorrow's refrigerants



ValuePlus

Total support – with value-adding options to fit your needs

Design

The fusion-bonding seals and holds the plates together at the contact points ensuring optimal heat transfer efficiency and pressure resistance. Using advanced design technologies and



extensive verification guarantees the highest performance and longest possible service life.

Different pressure ratings are available for different needs.

Based on standard components and a modular concept, each unit is custom-built to meet the specific requirements of each individual installation.

Examples of connections

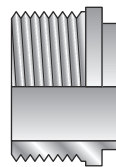

External thread

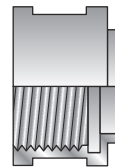

Internal thread

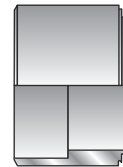

Soldering

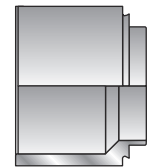

Welding

Technical Data

Standard materials

Cover plates	Stainless steel
Connections	Stainless steel
Plates	Stainless steel
AlfaFusion filler	Stainless steel

Dimensions and weight ¹

A-measurement (mm)	$12.3 + (2.18 * n)$
A-measurement (inches)	$0.48 + (0.09 * n)$
Weight (kg) ²	$2.94 + (0.22 * n)$
Weight (lb) ²	$6.48 + (0.49 * n)$

¹ n = number of plates

² Excluding connections

Standard data

Volume per channel, litres (gal)	0.147 (0.0388)
Max. particle size, mm (inch)	1 (0.039)
Max. flowrate ¹ m ³ /h (gpm)	14 (61.6)
Flow directions	Parallel
Min. number of plates	10
Max. number of plates	150

¹ Water at 5 m/s (16.4 ft/s) (connection velocity)

Dimensional Drawing

Measurements in mm (inches)

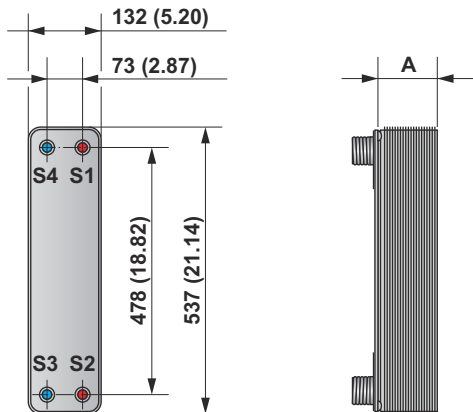

Design pressure and temperature

AlfaNova 66 - PED approved pressure/temperature graph

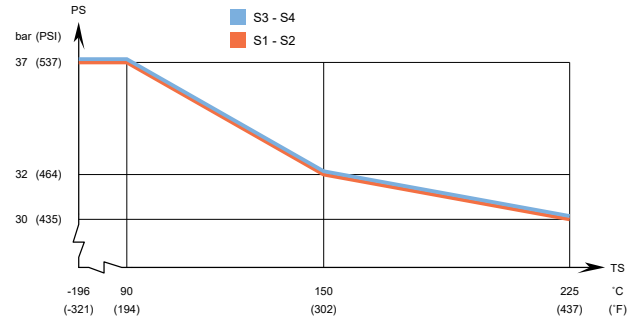

Designed for full vacuum.

Alfa Laval plate heat exchangers are available with a wide range of pressure vessel approvals. Please contact your Alfa Laval representative for more information.

NOTE: Values above are to be used as an indication. For exact values, please use the drawing generated by the Alfa Laval configurator or contact your local Alfa Laval representative.

Marine approvals

AlfaNova 66 can be delivered with marine classification certificate (ABS, BV, CCS, ClassNK, DNV-GL, KR, LR, RINA)

This document and its contents are subject to copyrights and other intellectual property rights owned by Alfa Laval AB (publ) or any of its affiliates (jointly "Alfa Laval"). No part of this document may be copied, re-produced or transmitted in any form or by any means, or for any purpose, without Alfa Laval's prior express written permission. Information and services provided in this document are made as a benefit and service to the user, and no representations or warranties are made about the accuracy or suitability of this information and these services for any purpose. All rights are reserved.

How to contact Alfa Laval

Up-to-date Alfa Laval contact details for all countries are always available on our website at www.alfalaval.com

Alfa Laval AlfaNova 14 / HP 14

Fusion-bonded plate heat exchanger in 100% stainless steel

Introduction

Alfa Laval AlfaNova fusion-bonded plate heat exchangers are made of 100% stainless steel. They are suitable for applications which place high demand on cleanliness, applications where aggressive media like ammonia are used or where copper and nickel contamination is unacceptable.

AlfaNova provides efficient heat transfer with a small footprint, has an extreme pressure fatigue resistance and covers high temperatures, up to 550°C/1022°F.

Applications

Suitable for a wide range of applications, such as:

- HVAC heating and cooling
- Refrigeration
- Oil cooling
- Industrial heating and cooling
- Process heating and cooling

Benefits

- Compact
- Easy to install
- Self-cleaning
- Low level of service and maintenance is required
- All units are pressure and leak tested
- Gasket free
- Copper free

Branded Features



AlfaNova

100% stainless steel



PressureSecure

Unparalleled strength for demanding duties



REFuture

A future-proof investment for tomorrow's refrigerants



ValuePlus

Total support – with value-adding options to fit your needs

Design

The AlfaFusion filler material seals and holds the plates together at the contact points ensuring optimal heat transfer efficiency and pressure resistance. Using advanced design



technologies and extensive verification guarantees the highest performance and longest possible service life.

Based on standard components and a modular concept, each unit is custom-built to meet the specific requirements of each individual installation.

Examples of connections

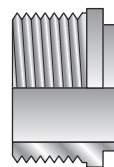

External thread

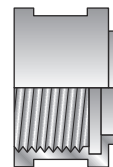

Internal thread

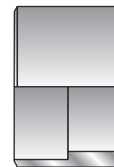

Soldering

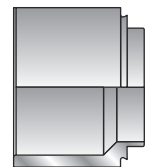

Welding

Technical Data

Standard materials

Cover plates	Stainless steel
Connections	Stainless steel
Plates	Stainless steel
AlfaFusion filler	Stainless steel

Dimensions and weight ¹

A measure (mm)	$8 + (2.48 * n)$
A measure (inches)	$0.31 + (0.10 * n)$
Weight (kg) ²	$0.4 + (0.07 * n)$
Weight (lb) ²	$0.88 + (0.15 * n)$

¹ n = number of plates

² Excluding connections

Standard data

Volume per channel, litres (gal)	0.02 (0.0053)
Max. particle size, mm (inch)	1.2 (0.047)
Max. flowrate ¹ m ³ /h (gpm)	4.6 (20.3)
Flow directions	Parallel
Min. number of plates	4
Max. number of plates	50

¹ Water at 5 m/s (16.4 ft/s) (connection velocity)

Dimensional Drawing

Measurements in mm (inches)

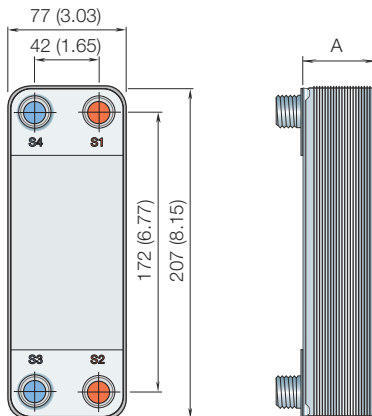

Design pressure and temperature

AlfaNova 14 - PED approved pressure/temperature graph

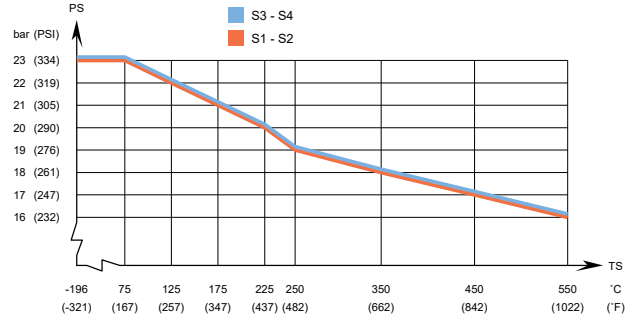

AlfaNova HP 14 - PED approved pressure/temperature graph

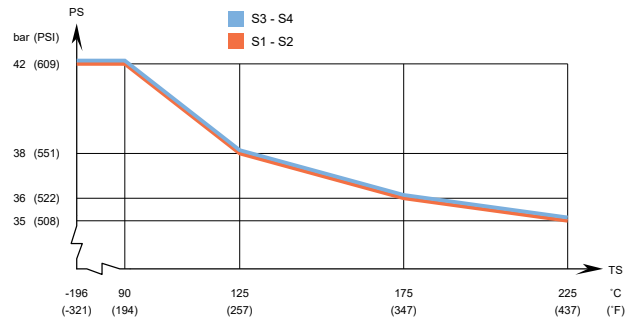

AlfaNova 14 - UL approved pressure/temperature graph

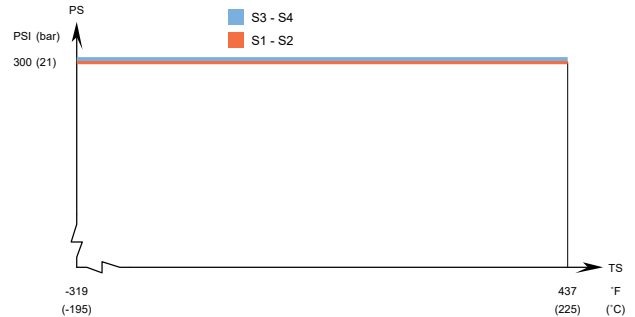

Designed for full vacuum.

Alfa Laval plate heat exchangers are available with a wide range of pressure vessel approvals. Please contact your Alfa Laval representative for more information.

NOTE: Values above are to be used as an indication. For exact values, please use the drawing generated by the Alfa Laval configurator or contact your local Alfa Laval representative.

This document and its contents are subject to copyrights and other intellectual property rights owned by Alfa Laval Corporate AB. No part of this document may be copied, re-produced or transmitted in any form or by any means, or for any purpose, without Alfa Laval Corporate AB's prior express written permission. Information and services provided in this document are made as a benefit and service to the user, and no representations or warranties are made about the accuracy or suitability of this information and these services for any purpose. All rights are reserved.

How to contact Alfa Laval

Up-to-date Alfa Laval contact details for all countries are always available on our website at www.alfalaval.com



Alfa Laval AlfaNova 27 / HP 27 / XP27

Fusion-bonded plate heat exchanger in 100% stainless steel

Introduction

Alfa Laval AlfaNova fusion-bonded plate heat exchangers are made of 100% stainless steel. They are suitable for applications which place high demand on cleanliness, applications where aggressive media like ammonia are used or where copper and nickel contamination is unacceptable.

AlfaNova provides efficient heat transfer with a small footprint, has an extreme pressure fatigue resistance and covers high temperatures, up to 550°C/1022°F.

Applications

Suitable for a wide range of applications, such as:

- HVAC heating and cooling
- Refrigeration
- Oil cooling
- Industrial heating and cooling
- Process heating and cooling

Benefits

- Compact
- Easy to install
- Self-cleaning
- Low level of service and maintenance is required
- All units are pressure and leak tested
- Gasket free
- Copper free

Branded Features



AlfaNova

100% stainless steel



PressureSecure

Unparalleled strength for demanding duties



REFuture

A future-proof investment for tomorrow's refrigerants



ValuePlus

Total support – with value-adding options to fit your needs

Design

The AlfaFusion filler material seals and holds the plates together at the contact points ensuring optimal heat transfer efficiency and pressure resistance. Using advanced design



technologies and extensive verification guarantees the highest performance and longest possible service life.

Different pressure ratings are available for different needs.

The XP design is particularly suited to CO₂ applications.

Based on standard components and a modular concept, each unit is custom-built to meet the specific requirements of each individual installation.

Examples of connections

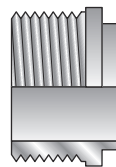

External thread

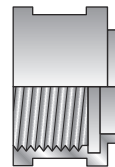

Internal thread



Soldering

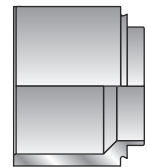

Welding

Technical Data

Standard materials

Cover plates	Stainless steel
Connections	Stainless steel
Plates	Stainless steel
AlfaFusion filler	Stainless steel

Dimensions and weight ¹

A-measurement (mm)	11 + (2.42 * n) HP: 13 + (2.42 * n) XP: 15 + (2.42 * n)
A-measurement (inches)	0.43 + (0.10 * n) HP: 0.51 + (0.10 * n) XP: 0.59 + (0.10 * n)
Weight (kg) ²	1 + (0.13 * n) HP: 1.5 + (0.13 * n) XP: 2 + (0.13 * n)
Weight (lb) ²	2.20 + (0.29 * n) HP: 3.31 + (0.29 * n) XP: 4.41 + (0.29 * n)

¹ n = number of plates

² Excluding connections

Standard data

Volume per channel, litres (gal)	0.05 (0.0132)
Max. particle size, mm (inch)	1.2 (0.047)
Max. flowrate ¹ m ³ /h (gpm)	14 (61.6)
Flow directions	Parallel
Min. number of plates	6
Max. number of plates	100

¹ Water at 5 m/s (16.4 ft/s) (connection velocity)

Dimensional Drawing

Measurements in mm (inches)

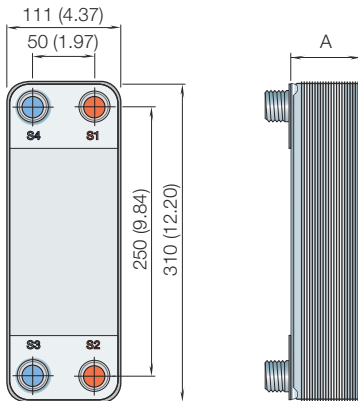

Design pressure and temperature

AlfaNova 27 - PED approved pressure/temperature graph

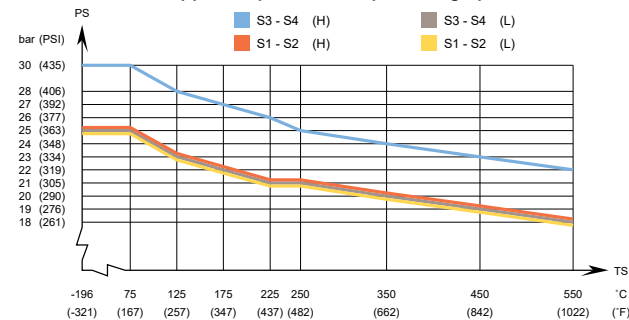

AlfaNova HP 27 - PED approved pressure/temperature graph

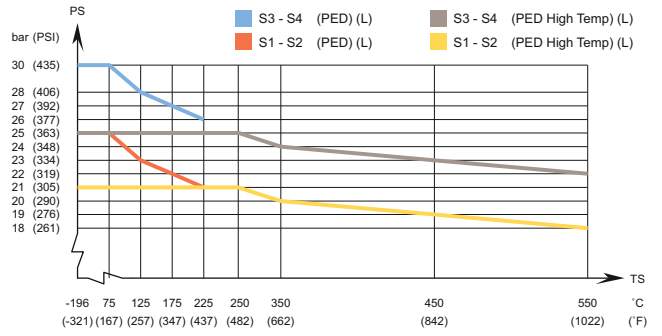

AlfaNova HP 27 - PED high temperature approved pressure/temperature graph

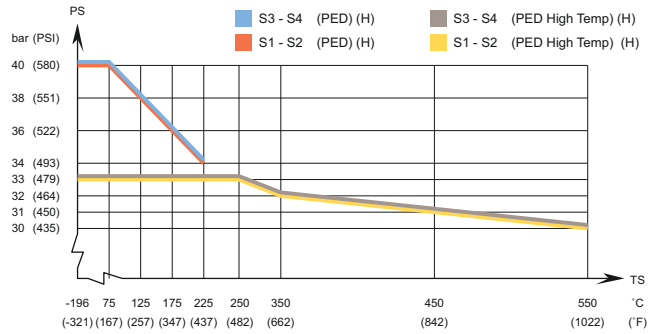

AlfaNova XP27 - PED approved pressure/temperature graph

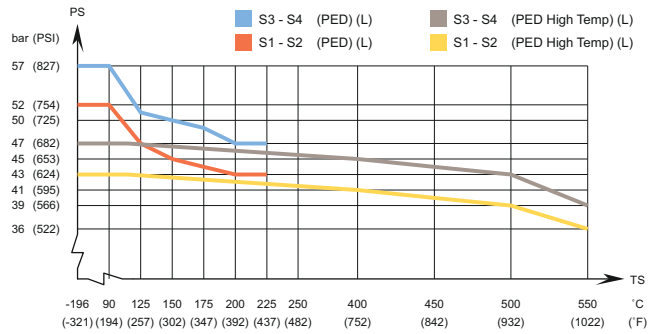

AlfaNova XP27 - PED high temperature approved pressure/temperature graph

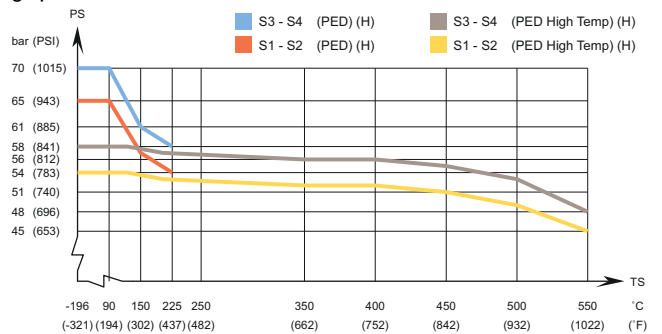

Designed for full vacuum.

Alfa Laval plate heat exchangers are available with a wide range of pressure vessel approvals. Please contact your Alfa Laval representative for more information.

NOTE: Values above are to be used as an indication. For exact values, please use the drawing generated by the Alfa Laval configurator or contact your local Alfa Laval representative.



Alfa Laval AlfaNova 52 / HP 52 / XP52

Fusion-bonded plate heat exchanger in 100% stainless steel

Introduction

Alfa Laval AlfaNova fusion-bonded plate heat exchangers are made of 100% stainless steel. They are suitable for applications which place high demand on cleanliness, applications where aggressive media like ammonia are used or where copper and nickel contamination is unacceptable.

AlfaNova provides efficient heat transfer with a small footprint, has an extreme pressure fatigue resistance and covers high temperatures, up to 550°C/1022°F.

Applications

Suitable for a wide range of applications, such as:

- HVAC heating and cooling
- Refrigeration
- Oil cooling
- Industrial heating and cooling
- Process heating and cooling

Benefits

- Compact
- Easy to install
- Self-cleaning
- Low level of service and maintenance is required
- All units are pressure and leak tested
- Gasket free
- Copper free

Branded Features



AlfaNova

100% stainless steel



PressureSecure

Unparalleled strength for demanding duties



REFuture

A future-proof investment for tomorrow's refrigerants



ValuePlus

Total support – with value-adding options to fit your needs

Design

The AlfaFusion filler material seals and holds the plates together at the contact points ensuring optimal heat transfer efficiency and pressure resistance. Using advanced design



technologies and extensive verification guarantees the highest performance and longest possible service life.

Different pressure ratings are available for different needs.

The XP design is particularly suited to CO₂ applications.

Based on standard components and a modular concept, each unit is custom-built to meet the specific requirements of each individual installation.

Examples of connections

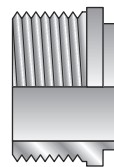

External thread

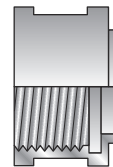

Internal thread

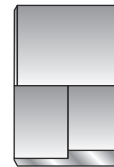

Soldering

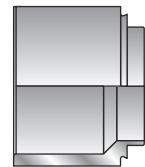

Welding

Technical Data

Standard materials

Cover plates	Stainless steel
Connections	Stainless steel
Plates	Stainless steel
AlfaFusion filler	Stainless steel

Dimensions and weight ¹

A measure (mm)	$11 + (2.48 * n)$
A measure (inches)	$0.43 + (0.10 * n)$
Weight (kg) ²	$1.9 + (0.22 * n)$
Weight (lb) ²	$4.19 + (0.49 * n)$

¹ n = number of plates

² Excluding connections

Standard data

Volume per channel, litres (gal)	0.095 (0.0251)
Max. particle size, mm (inch)	1.2 (0.047)
Max. flowrate ¹ m ³ /h (gpm)	14 (61.6)
Flow directions	Parallel
Min. number of plates	6
Max. number of plates	150

¹ Water at 5 m/s (16.4 ft/s) (connection velocity)

Dimensional Drawing

Measurements in mm (inches)

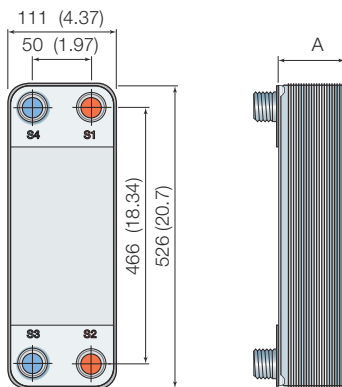

AlfaNova HP 52- PED approved pressure/temperature graph ¹

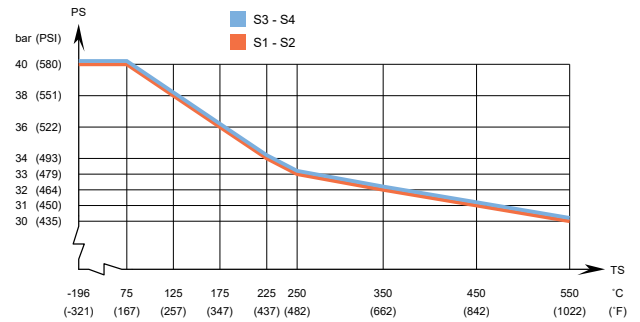

¹ Min. temperature -10°C (14°F) with connection tube made of carbon steel.

AlfaNova XP52 - PED approved pressure/temperature graph

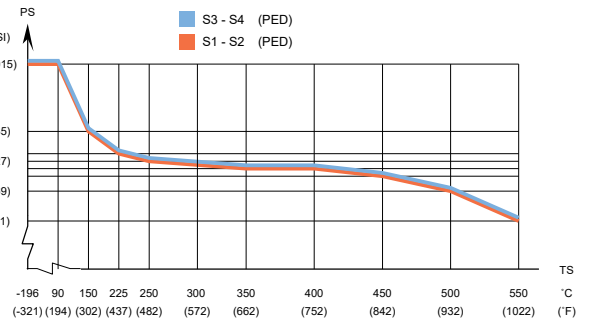

Designed for full vacuum.

Alfa Laval plate heat exchangers are available with a wide range of pressure vessel approvals. Please contact your Alfa Laval representative for more information.

NOTE: Values above are to be used as an indication. For exact values, please use the drawing generated by the Alfa Laval configurator or contact your local Alfa Laval representative.

Design pressure and temperature

AlfaNova 52 - PED approved pressure/temperature graph

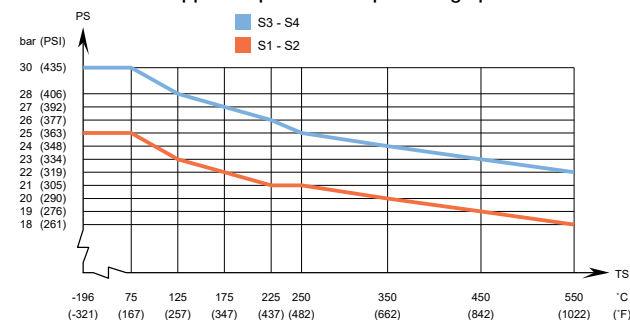

This document and its contents are subject to copyrights and other intellectual property rights owned by Alfa Laval Corporate AB. No part of this document may be copied, re-produced or transmitted in any form or by any means, or for any purpose, without Alfa Laval Corporate AB's prior express written permission. Information and services provided in this document are made as a benefit and service to the user, and no representations or warranties are made about the accuracy or suitability of this information and these services for any purpose. All rights are reserved.

How to contact Alfa Laval

Up-to-date Alfa Laval contact details for all countries are always available on our website at www.alfalaval.com



Alfa Laval AlfaNova 76 / HP 76

Fusion-bonded plate heat exchanger in 100% stainless steel

Introduction

Alfa Laval AlfaNova fusion-bonded plate heat exchangers are made of 100% stainless steel. They are suitable for applications which place high demand on cleanliness, applications where aggressive media like ammonia are used or where copper and nickel contamination is unacceptable.

AlfaNova provides efficient heat transfer with a small footprint, has an extreme pressure fatigue resistance and covers high temperatures, up to 550°C/1022°F.

Applications

Suitable for a wide range of applications, such as:

- HVAC heating and cooling
- Refrigeration
- Oil cooling
- Industrial heating and cooling
- Process heating and cooling

Benefits

- Compact
- Easy to install
- Self-cleaning
- Low level of service and maintenance is required
- All units are pressure and leak tested
- Gasket free
- Copper free

Branded Features



AlfaNova

100% stainless steel



PressureSecure

Unparalleled strength for demanding duties



REFuture

A future-proof investment for tomorrow's refrigerants



ValuePlus

Total support – with value-adding options to fit your needs

Design

The AlfaFusion filler material seals and holds the plates together at the contact points ensuring optimal heat transfer efficiency and pressure resistance. Using advanced design



technologies and extensive verification guarantees the highest performance and longest possible service life.

Different pressure ratings are available for different needs.

Based on standard components and a modular concept, each unit is custom-built to meet the specific requirements of each individual installation.

Examples of connections

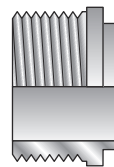

External thread

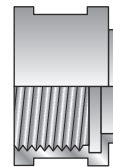

Internal thread

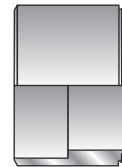

Soldering

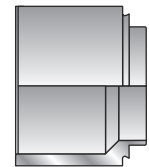

Welding

Technical Data

Standard materials

Cover plates	Stainless steel
Connections	Stainless steel
Plates	Stainless steel
AlfaFusion filler	Stainless steel

Dimensions and weight ¹

A-measurement (mm)	11 + (2.85 * n)
A-measurement (inches)	0.43 + (0.11 * n)
Weight (kg) ²	8 + (0.49 * n)
Weight (lb) ²	17.64 + (1.08 * n)

¹ n = number of plates

² Excluding connections

Standard data

Volume per channel, litres (gal)	(A) S1-S2: 0.25 (0.0660) (A) S3-S4: 0.18 (0.0476) (H, L): 0.25 (0.0660) (E): 0.18 (0.0476)
Max. particle size, mm (inch)	1.2 (0.047)
Max. flowrate ¹ m ³ /h (gpm)	37 (162.9)
Flow directions	Parallel
Min. number of plates	10
Max. number of plates	150

¹ Water at 5 m/s (16.4 ft/s) (connection velocity)

Dimensional Drawing

Measurements in mm (inches)

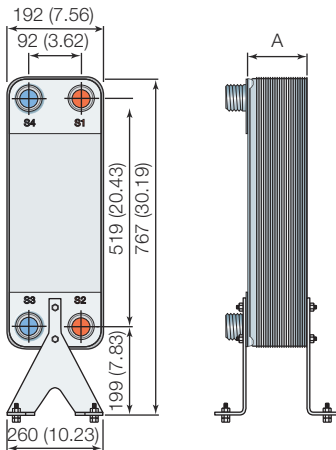

Design pressure and temperature

AlfaNova 76 – PED approval pressure/temperature graph ¹

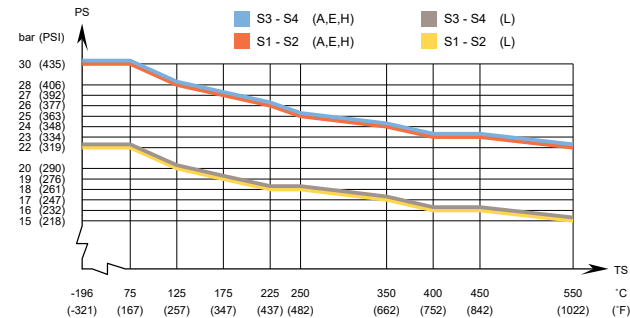

¹ Min. temperature -10°C (14°F) with connection tube made of carbon steel.

AlfaNova HP 76 – PED approval pressure/temperature graph ¹

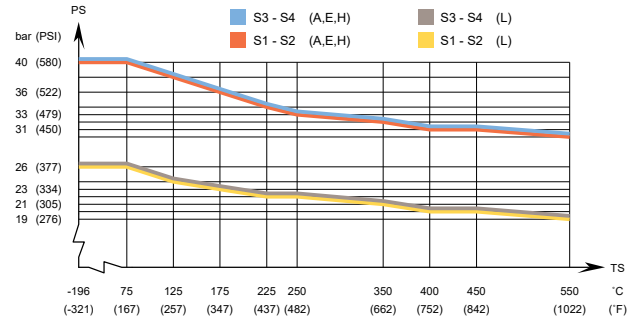

¹ Min. temperature -10°C (14°F) with connection tube made of carbon steel.

AlfaNova HP 76 – UL approval pressure/temperature graph

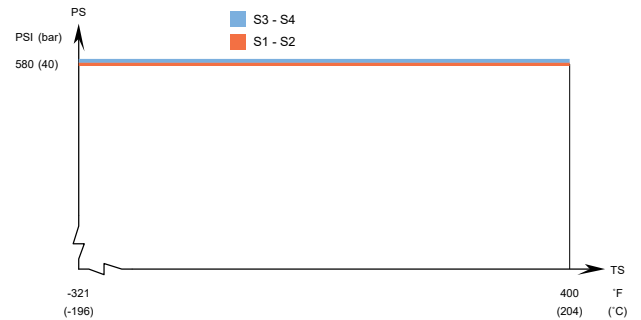

Designed for full vacuum.

Alfa Laval plate heat exchangers are available with a wide range of pressure vessel approvals. Please contact your Alfa Laval representative for more information.

NOTE: Values above are to be used as an indication. For exact values, please use the drawing generated by the Alfa Laval configurator or contact your local Alfa Laval representative.

Marine approvals

AlfaNovaM HP 76 can be delivered with marine classification certificate (ABS, BV, CCS, ClassNK, DNV-GL, KR, LR, RINA)



Alfa Laval AlfaNova 200 / HP 200

Fusion-bonded plate heat exchanger in 100% stainless steel

Introduction

Alfa Laval AlfaNova fusion-bonded plate heat exchangers are made of 100% stainless steel. They are suitable for applications which place high demand on cleanliness, applications where aggressive media like ammonia are used or where copper and nickel contamination is unacceptable.

AlfaNova provides efficient heat transfer with a small footprint, has an extreme pressure fatigue resistance and covers high temperatures, up to 550°C/1022°F.

Applications

Suitable for a wide range of applications, such as:

- HVAC heating and cooling
- Refrigeration
- Oil cooling
- Industrial heating and cooling
- Process heating and cooling

Benefits

- Compact
- Easy to install
- Self-cleaning
- Low level of service and maintenance is required
- All units are pressure and leak tested
- Gasket free
- Copper free

Branded Features



AlfaNova

100% stainless steel



PressureSecure

Unparalleled strength for demanding duties



REFuture

A future-proof investment for tomorrow's refrigerants



ValuePlus

Total support – with value-adding options to fit your needs

Design

The AlfaFusion filler material seals and holds the plates together at the contact points ensuring optimal heat transfer efficiency and pressure resistance. Using advanced design



technologies and extensive verification guarantees the highest performance and longest possible service life.

Different pressure ratings are available for different needs.

Based on standard components and a modular concept, each unit is custom-built to meet the specific requirements of each individual installation.

Examples of connections

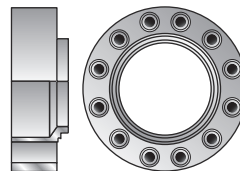

Compact flange

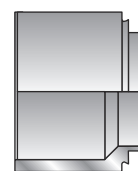

Welding



Clamp

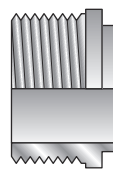

External thread

Technical Data

Standard materials

Cover plates	Stainless steel
Connections	Stainless steel
Plates	Stainless steel
AlfaFusion filler	Stainless steel

Dimensions and weight ¹

A measure (mm)	$9.3 + (2.85 * n)$
A measure (inches)	$0.37 + (0.11 * n)$
Weight (kg) ²	$12 + (0.75 * n)$
Weight (lb) ²	$26.46 + (1.65 * n)$

¹ n = number of plates

² Excluding connections

Standard data

Volume per channel, litres (gal)	0.51 (0.1347)
Max. particle size, mm (inch)	1 (0.039)
Max. flowrate ¹ m ³ /h (gpm)	112 (493.1)
Flow directions	Parallel
Min. number of plates	10
Max. number of plates	230

¹ Water at 5 m/s (16.4 ft/s) (connection velocity)

Dimensional Drawing

Measurements in mm (inches)

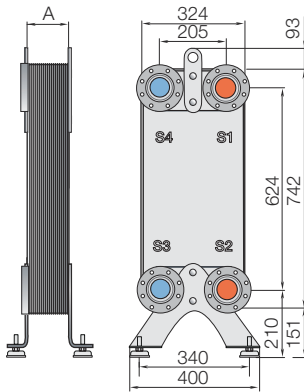

Design pressure and temperature

AlfaNova 200 – PED approval pressure/temperature graph

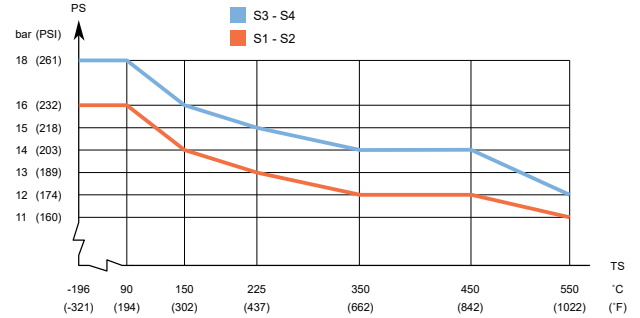

AlfaNova HP 200 – PED approval pressure/temperature graph

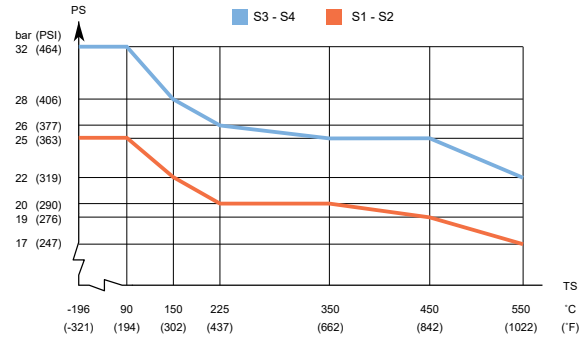

AlfaNova 200 – UL approval pressure/temperature graph

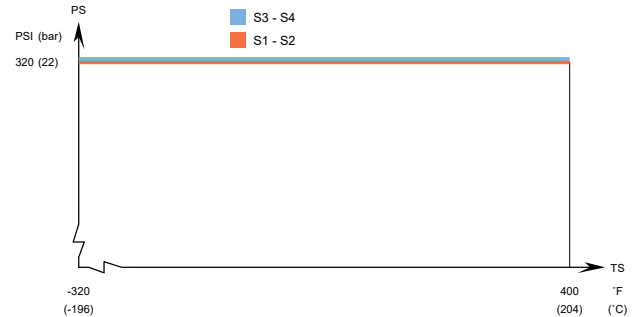

Designed for full vacuum.

Alfa Laval plate heat exchangers are available with a wide range of pressure vessel approvals. Please contact your Alfa Laval representative for more information.

NOTE: Values above are to be used as an indication. For exact values, please use the drawing generated by the Alfa Laval configurator or contact your local Alfa Laval representative.

This document and its contents are subject to copyrights and other intellectual property rights owned by Alfa Laval Corporate AB. No part of this document may be copied, re-produced or transmitted in any form or by any means, or for any purpose, without Alfa Laval Corporate AB's prior express written permission. Information and services provided in this document are made as a benefit and service to the user, and no representations or warranties are made about the accuracy or suitability of this information and these services for any purpose. All rights are reserved.

How to contact Alfa Laval

Up-to-date Alfa Laval contact details for all countries are always available on our website at www.alfalaval.com



Alfa Laval AlfaNova 400 / HP 400

Fusion-bonded plate heat exchanger in 100% stainless steel

Introduction

Alfa Laval AlfaNova fusion-bonded plate heat exchangers are made of 100% stainless steel. They are suitable for applications which place high demand on cleanliness, applications where aggressive media like ammonia are used or where copper and nickel contamination is unacceptable.

AlfaNova provides efficient heat transfer with a small footprint, has an extreme pressure fatigue resistance and covers high temperatures, up to 550°C/1022°F.

Applications

Suitable for a wide range of applications, such as:

- HVAC heating and cooling
- Refrigeration
- Oil cooling
- Industrial heating and cooling
- Process heating and cooling

Benefits

- Compact
- Easy to install
- Self-cleaning
- Low level of service and maintenance is required
- All units are pressure and leak tested
- Gasket free
- Copper free

Branded Features



AlfaNova

100% stainless steel



PressureSecure

Unparalleled strength for demanding duties



REFuture

A future-proof investment for tomorrow's refrigerants



ValuePlus

Total support – with value-adding options to fit your needs

Design

The AlfaFusion filler material seals and holds the plates together at the contact points ensuring optimal heat transfer efficiency and pressure resistance. Using advanced design



technologies and extensive verification guarantees the highest performance and longest possible service life.

Different pressure ratings are available for different needs.

Based on standard components and a modular concept, each unit is custom-built to meet the specific requirements of each individual installation.

Examples of connections



Compact flange

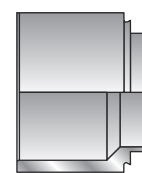
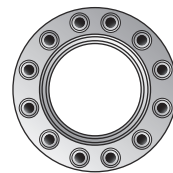

Welding



Clamp

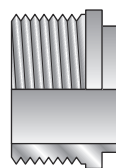

External thread

Technical Data

Standard materials

Cover plates	Stainless steel
Connections	Stainless steel
Plates	Stainless steel
AlfaFusion filler	Stainless steel

Dimensions and weight ¹

A-measurement (mm)	14 + (2.65 * n)
A-measurement (inches)	0.55 + (0.10 * n)
Weight (kg) ²	22 + (1.40 * n)
Weight (lb) ²	48.50 + (3.09 * n)

¹ n = number of plates

² Excluding connections

Standard data

Volume per channel, litres (gal)	0.74 (0.1955)
Max. particle size, mm (inch)	1.8 (0.071)
Max. flowrate ¹ m ³ /h (gpm)	200 (880.6)
Flow directions	Parallel
Min. number of plates	10
Max. number of plates	270

¹ Water at 5 m/s (16.4 ft/s) (connection velocity)

Dimensional Drawing

Measurements in mm (inches)

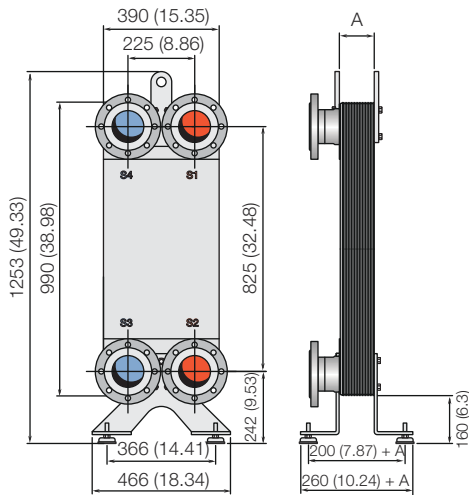

Design pressure and temperature

AlfaNova 400 – PED approval pressure/temperature graph ¹

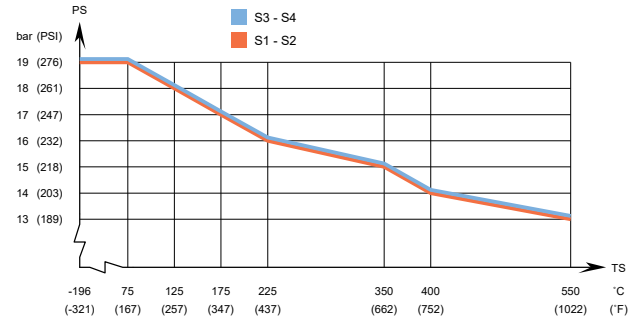

¹ Min. temperature -45°C (-49°F) with connection tube made of carbon steel.

AlfaNova HP 400 – PED approval pressure/temperature graph ¹

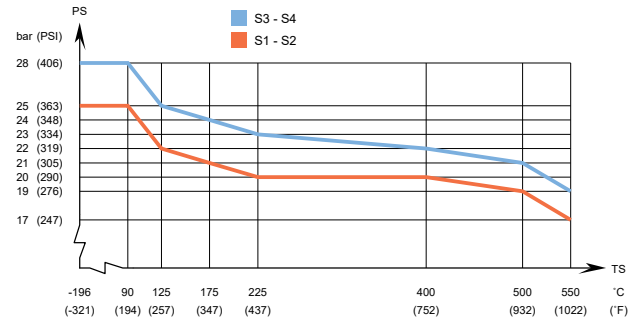

¹ Min. temperature -50°C (-58°F) with connection tube made of carbon steel.

Designed for full vacuum.

Alfa Laval plate heat exchangers are available with a wide range of pressure vessel approvals. Please contact your Alfa Laval representative for more information.

NOTE: Values above are to be used as an indication. For exact values, please use the drawing generated by the Alfa Laval configurator or contact your local Alfa Laval representative.

Marine approvals

AlfaNovaM HP 400 can be delivered with marine classification certificate (ABS, BV, CCS, ClassNK, DNV-GL, KR, LR, RINA)

This document and its contents are subject to copyrights and other intellectual property rights owned by Alfa Laval AB (publ) or any of its affiliates (jointly "Alfa Laval"). No part of this document may be copied, re-produced or transmitted in any form or by any means, or for any purpose, without Alfa Laval's prior express written permission. Information and services provided in this document are made as a benefit and service to the user, and no representations or warranties are made about the accuracy or suitability of this information and these services for any purpose. All rights are reserved.

How to contact Alfa Laval

Up-to-date Alfa Laval contact details for all countries are always available on our website at www.alfalaval.com

Alfa Laval AXP 27 AN

Fusion-bonded plate heat exchanger for extreme high-pressure applications

Introduction

Alfa Laval AXP AN is specially designed for high-pressure applications with requirements for 100% stainless steel, for example, high pressure ammonia systems or compressor cooling.

Applications

Designed for applications requiring 100% stainless steel.

Because of their high-pressure performance, they are particularly well-suited to CO₂ applications, such as transcritical gas cooling.

Benefits

- Tolerates extremely high operating pressures
- Compact
- Easy to install
- Self-cleaning
- Low level of service and maintenance is required
- All units are pressure and leak tested
- Gasket free
- Copper free

Design

The AlfaFusion filler material seals and holds the plates together at the contact points ensuring optimal heat transfer efficiency and pressure resistance. Using advanced design technologies and extensive verification guarantees the highest performance and longest possible service life.

AXP AN are fusion-bonded plate heat exchangers with thin external frames in carbon steel that are able to withstand extremely high operating pressures.

Always delivered with lifting lug for easy handling.

Examples of connections

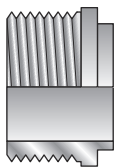

External thread

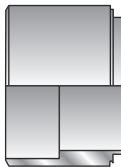

Soldering

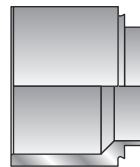

Welding



Technical Data

Standard materials

Cover plates	Stainless steel
Connections	Stainless steel
Plates	Stainless steel
AlfaFusion filler	Stainless steel
External frame	Carbon steel, Zinc electroplated

Dimensions and weight ¹

A measure (mm)	$15 + (2.42 * n)$
A measure (inches)	$0.59 + (0.10 * n)$
Weight (kg) ²	$21 + (0.13 * n)$
Weight (lb) ²	$46.30 + (0.29 * n)$

¹ n = number of plates

² Excluding connections

Standard data

Volume per channel, litres (gal)	0.05 (0.0132)
Max. particle size, mm (inch)	1.2 (0.047)
Max. flowrate ¹ m ³ /h (gpm)	14 (61.6)
Flow directions	Parallel
Min. number of plates	6
Max. number of plates	100

¹ Water at 5 m/s (16.4 ft/s) (connection velocity)

Dimensional Drawing

Measurements in mm (inches)

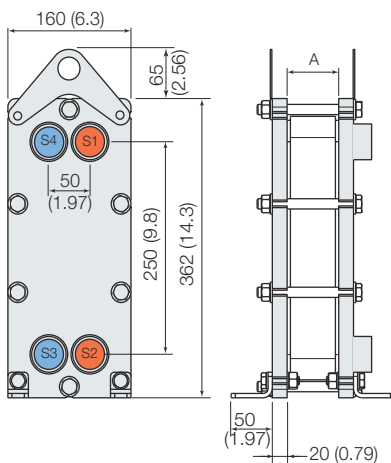

Design pressure and temperature

AXP27 AN - PED approved pressure/temperature graph

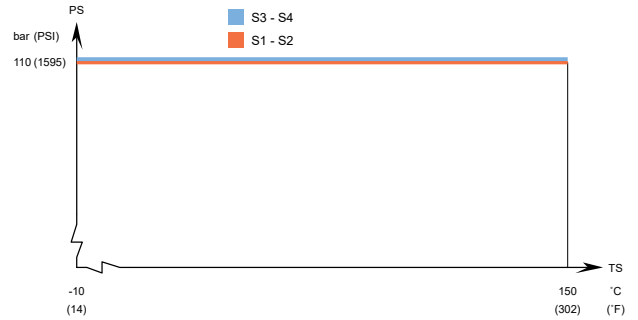

Designed for full vacuum.

Alfa Laval plate heat exchangers are available with a wide range of pressure vessel approvals. Please contact your Alfa Laval representative for more information.

NOTE: Values above are to be used as an indication. For exact values, please use the drawing generated by the Alfa Laval configurator or contact your local Alfa Laval representative.

This document and its contents are subject to copyrights and other intellectual property rights owned by Alfa Laval Corporate AB. No part of this document may be copied, re-produced or transmitted in any form or by any means, or for any purpose, without Alfa Laval Corporate AB's prior express written permission. Information and services provided in this document are made as a benefit and service to the user, and no representations or warranties are made about the accuracy or suitability of this information and these services for any purpose. All rights are reserved.

How to contact Alfa Laval

Up-to-date Alfa Laval contact details for all countries are always available on our website at www.alfalaval.com

Alfa Laval AXP 52 AN

Fusion-bonded plate heat exchanger for extreme high-pressure applications

Introduction

Alfa Laval AXP AN is specially designed for high-pressure applications with requirements for 100% stainless steel, for example, high pressure ammonia systems or compressor cooling.

Applications

Designed for applications requiring 100% stainless steel.

Because of their high-pressure performance, they are particularly well-suited to CO₂ applications, such as transcritical gas cooling.

Benefits

- Tolerates extremely high operating pressures
- Compact
- Easy to install
- Self-cleaning
- Low level of service and maintenance is required
- All units are pressure and leak tested
- Gasket free
- Copper free

Design

The AlfaFusion filler material seals and holds the plates together at the contact points ensuring optimal heat transfer efficiency and pressure resistance. Using advanced design technologies and extensive verification guarantees the highest performance and longest possible service life.

AXP AN are fusion-bonded plate heat exchangers with thin external frames in carbon steel that are able to withstand extremely high operating pressures.

Always delivered with lifting lug for easy handling.

Examples of connections

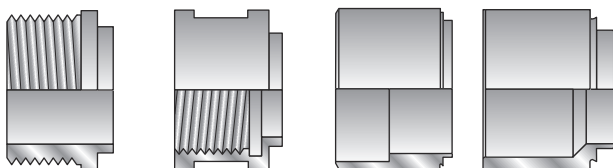

External thread

Internal thread

Soldering

Welding



Technical Data

Standard materials

Cover plates	Stainless steel
Connections	Stainless steel
Plates	Stainless steel
AlfaFusion filler	Stainless steel
External frame	Carbon steel, Zinc electroplated

Dimensions and weight ¹

A measure (mm)	$15 + (2.48 * n)$
A measure (inches)	$0.59 + (0.10 * n)$
Weight (kg) ²	$38 + (0.22 * n)$
Weight (lb) ²	$83.77 + (0.49 * n)$

¹ n = number of plates

² Excluding connections

Standard data

Volume per channel, litres (gal)	0.095 (0.0251)
Max. particle size, mm (inch)	1.2 (0.047)
Max. flowrate ¹ m ³ /h (gpm)	14 (61.6)
Flow directions	Parallel
Min. number of plates	6
Max. number of plates	150

¹ Water at 5 m/s (16.4 ft/s) (connection velocity)

Dimensional Drawing

Measurements in mm (inches)

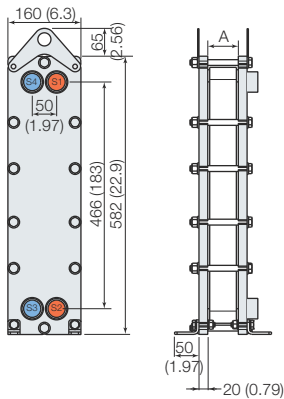

Design pressure and temperature

AXP52 AN - PED approved pressure/temperature graph

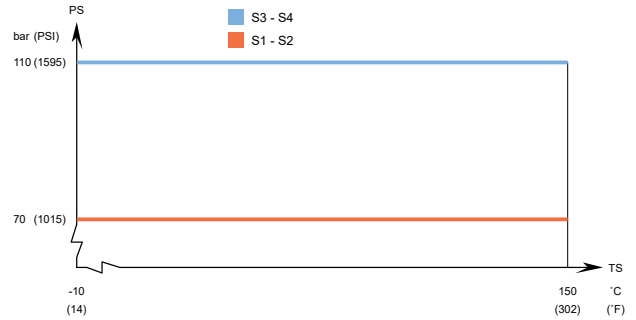

Designed for full vacuum.

Alfa Laval plate heat exchangers are available with a wide range of pressure vessel approvals. Please contact your Alfa Laval representative for more information.

NOTE: Values above are to be used as an indication. For exact values, please use the drawing generated by the Alfa Laval configurator or contact your local Alfa Laval representative.

This document and its contents are subject to copyrights and other intellectual property rights owned by Alfa Laval Corporate AB. No part of this document may be copied, re-produced or transmitted in any form or by any means, or for any purpose, without Alfa Laval Corporate AB's prior express written permission. Information and services provided in this document are made as a benefit and service to the user, and no representations or warranties are made about the accuracy or suitability of this information and these services for any purpose. All rights are reserved.

How to contact Alfa Laval

Up-to-date Alfa Laval contact details for all countries are always available on our website at www.alfalaval.com

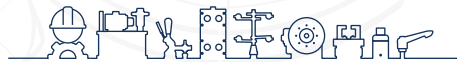

inf @ /CESEHSA.com.mx

