

SDS 10/12/14 Series



Engineering Data

Model	Stroke(mm)	Max.Energy / Cycle (Nm)	Max.Energy / Hour (Nm / h)	Effective Weight (kg)			Recoil Force (N)		Weight (g)
				S	M	H	Ext.	Comp.	
SDS10-08(B)	8	10	13,200	1.6-5.0	3.2-14	10.2-41	2.6	7	15
SDS12-10(B)	10	16	30,000	1.3-8	6.6-22	16-65	3.8	9.8	23
SDS14-15(B)	15	30	51,000	3.8-15	12-42	31-1,500	3.8	13	43

Dimensions

Model	Stroke	A	B	C	D	E	F	G	H	M	Dr
SDS10-08(B)	8	64.5	7.5	42	7	57.5	Ø 8.6	Ø 8.6	8	M10 X 1.0	Ø 3
SDS12-10(B)	10	80.5	6.5	54	10	70.5	Ø 10.8	Ø 10.5	10	M12 X 1.0	Ø 4
SDS14-15(B) SDS14-15F(B)	15	100.5	6.5	69	10	90.5	Ø 11.8	Ø 10.5	12	M14 X 1.5 M14 X 1.0	Ø 4

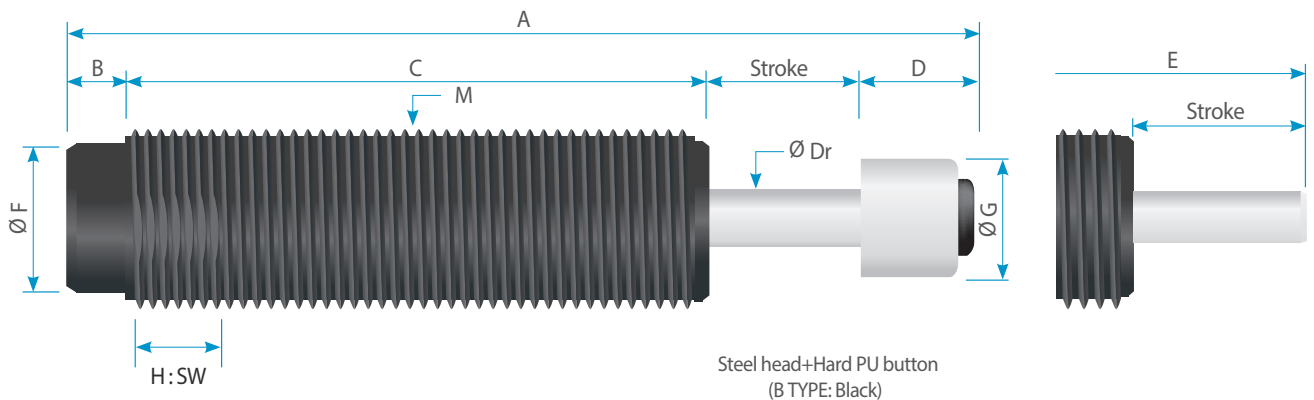

Accessories

Model	Stop Collar				Clamp Mount						Lock Nut		
	A1	A2	A3	A4	C1	C2	C3	C4	C5	C6	D1	D2	D3
SDS10-08(B)	20	8	Ø 12.8	M10 X 1.0	16	14	25	10	M10 X 1.0	M4 X 16L	13	M10 X 1.0	4
SDS12-10(B)	20	8	Ø 13.8	M12 X 1.0	20	16	32	12	M12 X 1.0	M5 X 18L	14	M12 X 1.0	4
SDS14-15(B) SDS14-15F(B)	27	12	Ø 18	M14 X 1.5 M14X1.0	20	20	32	12	M14 X 1.5 M14X1.0	M5 X 25L	19	M14 X 1.5 M14X1.0	5

