

SDA 36 Series



Engineering Data

Model	Stroke(mm)	Max.Energy / Cycle (Nm)	Max.Energy / Hour [Nm / h]	Effective Weight (kg)	Recoil Force (N)		Weight (g)
					Ext.	Comp.	
SDA36-25(B)	25	300	108,000	24-6,667	25	56.2	725
SDA36-50(B)	50	615	142,000	49-13,667	22.5	60	885

Dimensions

Model	Stroke	A	B	C	D	E	F	G	H	M	Dr
SDA36-25(B)	25	158.5	2	116	15.5	143	Ø 31	Ø 28	34	M36 X 1.5	Ø 10
SDA36-50(B)	50	218	2	150.5	15.5	202.5	Ø 31	Ø 28	34	M36 X 1.5	Ø 10

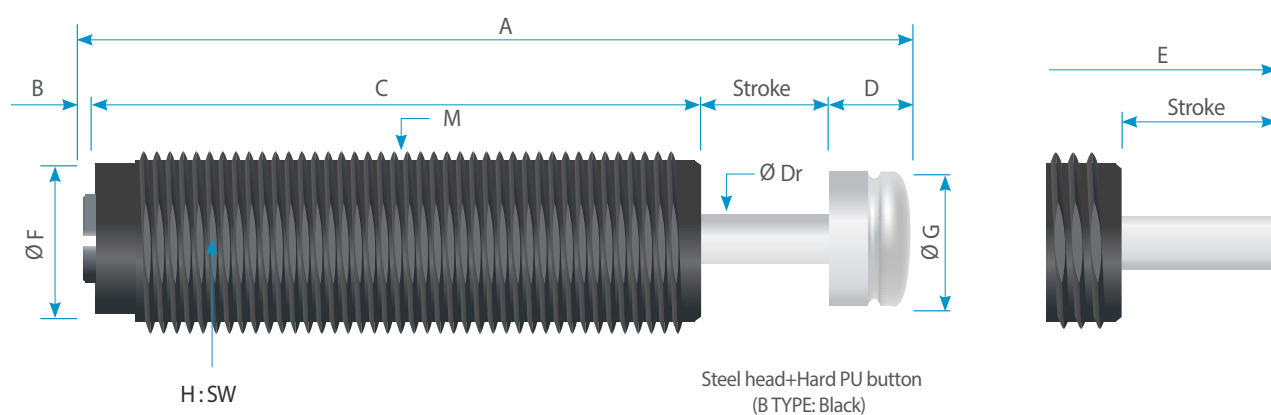

Accessories

Model	Stop Collar				Rectangular Flange						Clamp Mount						Lock Nut		
	A1	A2	A3	A4	B1	B2	B3	B4	B5	B6	C1	C2	C3	C4	C5	C6	D1	D2	D3
SDA36-25(B)	62	26	Ø 45	M36 X 15	51	41	45	29	10	4-Ø20	45	42	61	25	M36 X 1.5	M6 X 45L	46	M36 X 1.5	10

