



INDEXING PLUNGERS



Table of Contents

Indexing Plungers



Indexing Plungers Grub Screws Thrust Pads

Indexing Plungers pull knob K0338		INCH Parts	Page 330
		METRIC Parts	

Indexing Plungers pull knob K0338		INCH Parts	Page 334
		METRIC Parts	

Indexing Plungers pull knob, with extended locking pin K0630		INCH Parts	Page 338
		METRIC Parts	

Indexing Plungers pull knob, short version K0631		INCH Parts	Page 342
		METRIC Parts	

Indexing Plungers pull knob, stainless steel K0632		 INCH Parts	Page 344
		METRIC Parts	

Indexing Plungers pull knob K0339		INCH Parts	Page 346
		METRIC Parts	

Indexing plunger for thin-walled parts K0735		METRIC Parts	Page 348

Indexing Plungers K0340		INCH Parts	Page 349
		METRIC Parts	

Indexing Plungers threaded pin K0341		INCH Parts	Page 350
		METRIC Parts	

Indexing Plungers K0342		METRIC Parts	Page 354

Indexing Plungers without collar K0343		METRIC Parts	Page 356
		INCH Parts	

Indexing Plungers without collar with extended locking pin K0633		INCH Parts	Page 360
		METRIC Parts	

Indexing Plungers without collar, stainless steel K0634		 INCH Parts	Page 364
		METRIC Parts	

Indexing Plungers without collar K0345		INCH Parts	Page 366
		METRIC Parts	

Cam Action Indexing Plungers K0348		INCH Parts	Page 370
		METRIC Parts	

Cam Action Indexing Plungers stainless steel K0637		 INCH Parts	Page 372
		METRIC Parts	

Mounting brackets aluminum K0638		METRIC Parts	Page 374

Table of Contents

Indexing Plungers



Mounting brackets
K0638

New Item



METRIC
Parts

Page 376

Precision Indexing Plungers
with tapered pins
K0359



METRIC
Parts

Page 378

Tapered Bushings
K0360



METRIC
Parts

Page 379

Precision Indexing Plungers
with cylindrical pins
K0361



METRIC
Parts

Page 380

Cylindrical Bushings
K0362



METRIC
Parts

INCH
Parts

Page 381

Grub Screws
with thrust point to DIN 6332
K0390



METRIC
Parts

Page 382, 436

Grub Screws
with ball thrust point
K0391



METRIC
Parts

Page 383, 437

Thrust Screws stainless steel
K0667



METRIC
Parts

Page 384

Thrust Pads
DIN 6311 extended
K0392



METRIC
Parts

Page 385

Thrust Pads
K0393



METRIC
Parts

Page 386

Ball head position adjusters
K0691



METRIC
Parts

Page 387

Indexing Plungers

pull knob

INCH
Parts



Style A
non-lockout type
without locknut

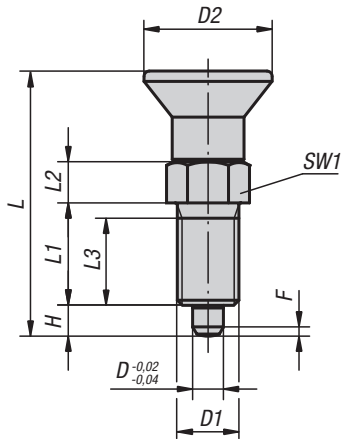

Style B
non-lockout type
with locknut

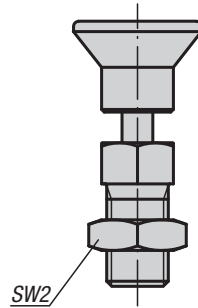

Style C
lockout type
without locknut

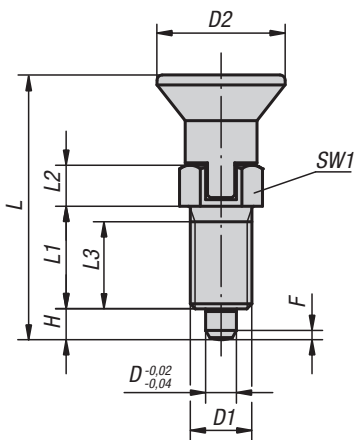

Style D
lockout type
with locknut

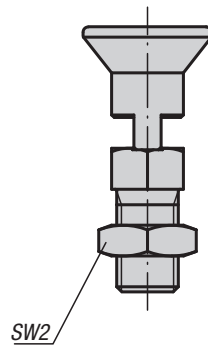

Material:

- Steel version, locking pin hardened: quality class 5.8
- Stainless steel version, locking pin hardened: threaded sleeve 1.4305 locking pin 1.4034
- Stainless steel version, locking pin not hardened: threaded sleeve 1.4305 locking pin 1.4305

Mushroom knob in black gray thermoplastic

Type:

- Steel version, locking pin hardened: black oxide finish, locking pin ground
- Stainless steel version, locking pin hardened: natural finish, locking pin ground
- Stainless steel version, locking pin not hardened: natural finish, locking pin ground

Part Number Example:

K0338.1903AJ

Note:

Indexing Plungers are used to prevent any change in locking position due to lateral forces. A new locking position can only be set after the bolt has been manually disengaged. Style C or D is recommended for applications in which gradual disengagement of the locking bolt is desired where a springing back of the pin should be prevented.

On request:

Special versions and spacer rings.

KIPP Indexing Plungers, pull knob, steel, locking pin hardened, inch

Item No. Style A	Item No. Style B	Item No. Style C	Item No. Style D	D	D1	D2	L	L1	L2	L3	H	SW1	SW2	F x 30°	Spring force initial pressure F1 approx. N	Spring force final pressure F2 approx. N
K0338.1903AJ	K0338.2903AJ	K0338.3903AJ	K0338.4903AJ	3	1/4-28	14	31,5	12	5	10	3,5	8	-7/16/-7/16	0,8	4,5	10
K0338.1004AK	K0338.2004AK	K0338.3004AK	K0338.4004AK	4	5/16-24	18	38,5	15	6	13	4	10	-1/2/-1/2	1	6	12
K0338.1105AL	K0338.2105AL	K0338.3105AL	K0338.4105AL	5	3/8-24	21	43,5	17	7	15	5	13	-9/16/-9/16	1,3	5	12
K0338.1206A5	K0338.2206A5	K0338.3206A5	K0338.4206A5	6	1/2-13	25	51,7	20	8	16	6	14	-3/4/-3/4	1,8	6	14
K0338.1308A6	K0338.2308A6	K0338.3308A6	K0338.4308A6	8	5/8-11	33	68	26	10	21	8	19	-15/16/-15/16	2,3	15	35
K0338.1410A7	K0338.2410A7	K0338.3410A7	K0338.4410A7	10	3/4-10	33	74	28	12	23	10	22	-1,125/-1,125	2,8	15	40
K0338.1412A0	K0338.2412A0	K0338.3412A0	K0338.4412A0	12	3/4-16	33	78	28	14	25	12	22	-1,125/-1,125	2,8	15	39
K0338.1516A8	K0338.2516A8	K0338.3516A8	K0338.4516A8	16	1-8	40	96	32	18	28	16	27	-1,5/-1,5	3,2	20	46

Indexing Plungers

pull knob

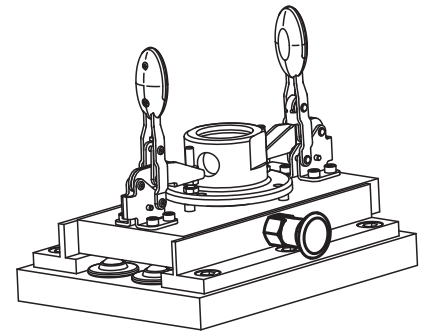

KIPP Indexing Plungers, pull knob, stainless steel, locking pin hardened, inch

Item No. Style A	Item No. Style B	Item No. Style C	Item No. Style D	D	D1	D2	L	L1	L2	L3	H	SW1	SW2	F x 30°	Spring force initial pressure F1 approx. N	Spring force final pressure F2 approx. N
K0338.01903AJ	K0338.02903AJ	K0338.03903AJ	K0338.04903AJ	3	1/4-28	14	31,5	12	5	10	3,5	8	-7/16/-7/16	0,8	4,5	10
K0338.01004AK	K0338.02004AK	K0338.03004AK	K0338.04004AK	4	5/16-24	18	38,5	15	6	13	4	10	-1/2/-1/2	1	6	12
K0338.01105AL	K0338.02105AL	K0338.03105AL	K0338.04105AL	5	3/8-24	21	43,5	17	7	15	5	13	-9/16/-9/16	1,3	5	12
K0338.01206A5	K0338.02206A5	K0338.03206A5	K0338.04206A5	6	1/2-13	25	51,7	20	8	16	6	14	-3/4/-3/4	1,8	6	14
K0338.01308A6	K0338.02308A6	K0338.03308A6	K0338.04308A6	8	5/8-11	33	68	26	10	21	8	19	-15/16/-15/16	2,3	15	35
K0338.01410A7	K0338.02410A7	K0338.03410A7	K0338.04410A7	10	3/4-10	33	74	28	12	23	10	22	-1,125/-1,125	2,8	15	40
K0338.01412A0	K0338.02412A0	K0338.03412A0	K0338.04412A0	12	3/4-16	33	78	28	14	25	12	22	-1,125/-1,125	2,8	15	39
K0338.01516A8	K0338.02516A8	K0338.03516A8	K0338.04516A8	16	1-8	40	96	32	18	28	16	27	-1,5/-1,5	3,2	20	46

KIPP Indexing Plungers, pull knob, stainless steel, locking pin not hardened, inch

Item No. Style A	Item No. Style B	Item No. Style C	Item No. Style D	D	D1	D2	L	L1	L2	L3	H	SW1	SW2	F x 30°	Spring force initial pressure F1 approx. N	Spring force final pressure F2 approx. N
K0338.11903AJ	K0338.12903AJ	K0338.13903AJ	K0338.14903AJ	3	1/4-28	14	31,5	12	5	10	3,5	8	-7/16/-7/16	0,8	4,5	10
K0338.11004AK	K0338.12004AK	K0338.13004AK	K0338.14004AK	4	5/16-24	18	38,5	15	6	13	4	10	-1/2/-1/2	1	6	12
K0338.11105AL	K0338.12105AL	K0338.13105AL	K0338.14105AL	5	3/8-24	21	43,5	17	7	15	5	13	-9/16/-9/16	1,3	5	12
K0338.11206A5	K0338.12206A5	K0338.13206A5	K0338.14206A5	6	1/2-13	25	51,7	20	8	16	6	14	-3/4/-3/4	1,8	6	14
K0338.11308A6	K0338.12308A6	K0338.13308A6	K0338.14308A6	8	5/8-11	33	68	26	10	21	8	19	-15/16/-15/16	2,3	15	35
K0338.11410A7	K0338.12410A7	K0338.13410A7	K0338.14410A7	10	3/4-10	33	74	28	12	23	10	22	-1,125/-1,125	2,8	15	40
K0338.11412A0	K0338.12412A0	K0338.13412A0	K0338.14412A0	12	3/4-16	33	78	28	14	25	12	22	-1,125/-1,125	2,8	15	39
K0338.11516A8	K0338.12516A8	K0338.13516A8	K0338.14516A8	16	1-8	40	96	32	18	28	16	27	-1,5/-1,5	3,2	20	46

Indexing Plungers

pull knob

METRIC
Parts



Style A
non-lockout type
without locknut

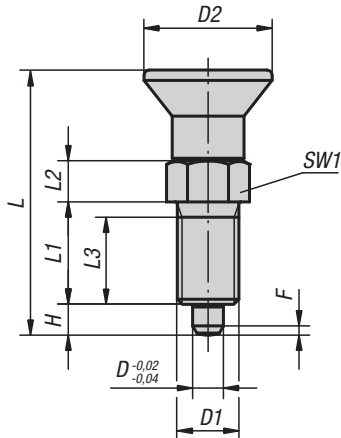

Style B
non-lockout type
with locknut

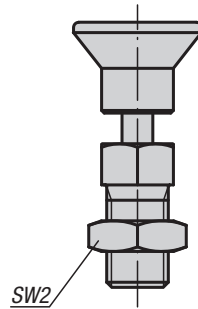

Style C
lockout type
without locknut

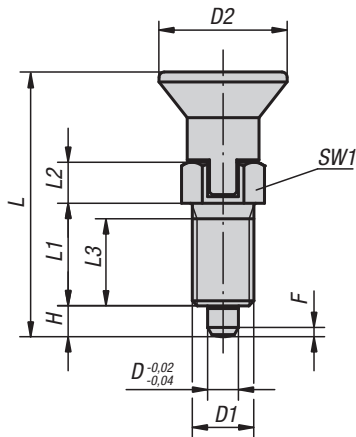

Style D
lockout type
with locknut

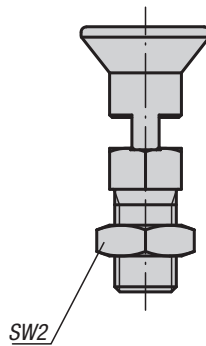

Material:

- Steel version, locking pin hardened: quality class 5.8
- Stainless steel version, locking pin hardened: threaded sleeve 1.4305 locking pin 1.4034
- Stainless steel version, locking pin not hardened: threaded sleeve 1.4305 locking pin 1.4305

Mushroom knob in black gray thermoplastic

Type:

- Steel version, locking pin hardened: black oxide finish, locking pin ground
- Stainless steel version, locking pin hardened: natural finish, locking pin ground
- Stainless steel version, locking pin not hardened: natural finish, locking pin ground

Part Number Example:

K0338.1903AJ

Note:

Indexing Plungers are used to prevent any change in locking position due to lateral forces. A new locking position can only be set after the bolt has been manually disengaged. Style C or D is recommended for applications in which gradual disengagement of the locking bolt is desired where a springing back of the pin should be prevented.

On request:

Special versions and spacer rings.

KIPP Indexing Plungers, pull knob, steel, locking pin hardened, metric

Item No. Style A	Item No. Style B	Item No. Style C	Item No. Style D	D	D1	D2	L	L1	L2	L3	H	SW1	SW2	F x 30°	Spring force initial pressure F1 approx. N	Spring force final pressure F2 approx. N
K0338.1903	K0338.2903	K0338.3903	K0338.4903	3	M6x0,75	14	31,5	12	5	10	3,5	8	-10/-10	0,8	4,5	10
K0338.1004	K0338.2004	K0338.3004	K0338.4004	4	M8x1	18	38,5	15	6	13	4	10	-13/-13	1	6	12
K0338.1105	K0338.2105	K0338.3105	K0338.4105	5	M10x1	21	43,5	17	7	15	5	13	-17/-17	1,3	5	12
K0338.1206	K0338.2206	K0338.3206	K0338.4206	6	M12x1,5	25	51,7	20	8	17	6	14	-19/-19	1,8	6	14
K0338.1308	K0338.2308	K0338.3308	K0338.4308	8	M16x1,5	33	68	26	10	23	8	19	-24/-24	2,3	15	35
K0338.1410	K0338.2410	K0338.3410	K0338.4410	10	M20x1,5	33	74	28	12	25	10	22	-30/-30	2,8	15	34
K0338.1412	K0338.2412	K0338.3412	K0338.4412	12	M20x1,5	33	78	28	14	25	12	22	-30/-30	2,8	15	39
K0338.1516	K0338.2516	K0338.3516	K0338.4516	16	M24x2	40	96	32	18	28	16	27	-36/-36	3,2	20	46

Indexing Plungers

pull knob

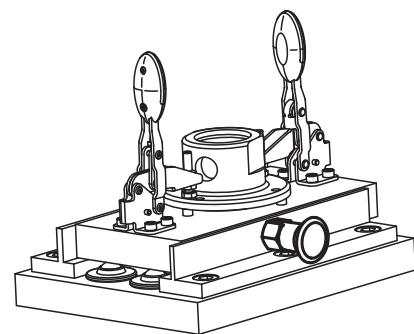

KIPP Indexing Plungers, pull knob, stainless steel, locking pin hardened, metric

Item No. Style A	Item No. Style B	Item No. Style C	Item No. Style D	D	D1	D2	L	L1	L2	L3	H	SW1	SW2	F x 30°	Spring force initial pressure F1 approx. N	Spring force final pressure F2 approx. N
K0338.01903	K0338.02903	K0338.03903	K0338.04903	3	M6x0,75	14	31,5	12	5	10	3,5	8	-/10-/10	0,8	4,5	10
K0338.01004	K0338.02004	K0338.03004	K0338.04004	4	M8x1	18	38,5	15	6	13	4	10	-/13-/13	1	6	12
K0338.01105	K0338.02105	K0338.03105	K0338.04105	5	M10x1	21	43,5	17	7	15	5	13	-/17-/17	1,3	5	12
K0338.01206	K0338.02206	K0338.03206	K0338.04206	6	M12x1,5	25	51,7	20	8	17	6	14	-/19-/19	1,8	6	14
K0338.01308	K0338.02308	K0338.03308	K0338.04308	8	M16x1,5	33	68	26	10	23	8	19	-/24-/24	2,3	15	35
K0338.01410	K0338.02410	K0338.03410	K0338.04410	10	M20x1,5	33	74	28	12	25	10	22	-/30-/30	2,8	15	34
K0338.01412	K0338.02412	K0338.03412	K0338.04412	12	M20x1,5	33	78	28	14	25	12	22	-/30-/30	2,8	15	39
K0338.01516	K0338.02516	K0338.03516	K0338.04516	16	M24x2	40	96	32	18	28	16	27	-/36-/36	3,2	20	46

KIPP Indexing Plungers, pull knob, stainless steel, locking pin not hardened, metric

Item No. Style A	Item No. Style B	Item No. Style C	Item No. Style D	D	D1	D2	L	L1	L2	L3	H	SW1	SW2	F x 30°	Spring force initial pressure F1 approx. N	Spring force final pressure F2 approx. N
K0338.11903	K0338.12903	K0338.13903	K0338.14903	3	M6x0,75	14	31,5	12	5	10	3,5	8	-/10-/10	0,8	4,5	10
K0338.11004	K0338.12004	K0338.13004	K0338.14004	4	M8x1	18	38,5	15	6	13	4	10	-/13-/13	1	6	12
K0338.11105	K0338.12105	K0338.13105	K0338.14105	5	M10x1	21	43,5	17	7	15	5	13	-/17-/17	1,3	5	12
K0338.11206	K0338.12206	K0338.13206	K0338.14206	6	M12x1,5	25	51,7	20	8	17	6	14	-/19-/19	1,8	6	14
K0338.11308	K0338.12308	K0338.13308	K0338.14308	8	M16x1,5	33	68	26	10	23	8	19	-/24-/24	2,3	15	35
K0338.11410	K0338.12410	K0338.13410	K0338.14410	10	M20x1,5	33	74	28	12	25	10	22	-/30-/30	2,8	15	34
K0338.11412	K0338.12412	K0338.13412	K0338.14412	12	M20x1,5	33	78	28	14	25	12	22	-/30-/30	2,8	15	39
K0338.11516	K0338.12516	K0338.13516	K0338.14516	16	M24x2	40	96	32	18	28	16	27	-/36-/36	3,2	20	46

Indexing Plungers

pull knob

INCH
Parts

New Item



Style A
non-lockout type
without locknut

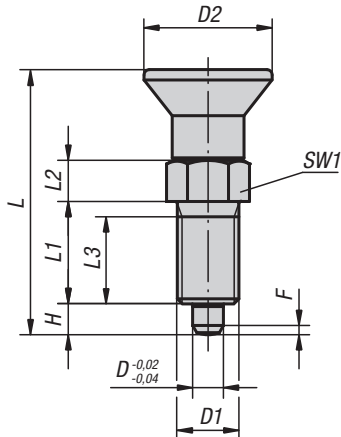

Style B
non-lockout type
with locknut

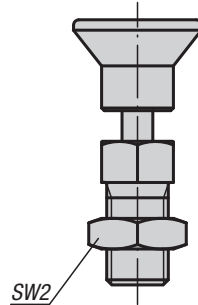

Style C
lockout type
without locknut

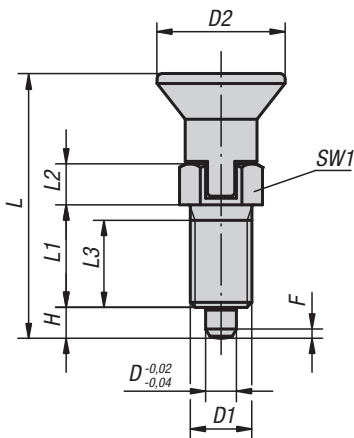

Style D
lockout type
with locknut

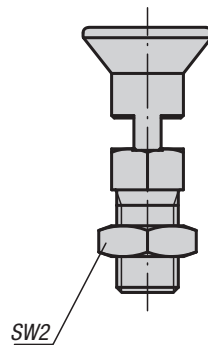

Material:

- Steel version, locking pin hardened: quality class 5.8
- Stainless steel version, locking pin hardened: threaded sleeve 1.4305 locking pin 1.4034
- Stainless steel version, locking pin not hardened: threaded sleeve 1.4305 locking pin 1.4305

Mushroom knob in red thermoplastic

Type:

- Steel version, locking pin hardened: black oxide finish, locking pin ground
- Stainless steel version, locking pin hardened: natural finish, locking pin ground
- Stainless steel version, locking pin not hardened: natural finish, locking pin ground

Order information:

K0338.0420684

Note:

Indexing Plungers are used to prevent any change in locking position due to lateral forces. A new locking position can only be set after the bolt has been manually disengaged. Style C or D is recommended for applications in which gradual disengagement of the locking bolt is desired where a springing back of the pin should be prevented.

On request:

Special versions.

Accessories:

Spacer rings K0665

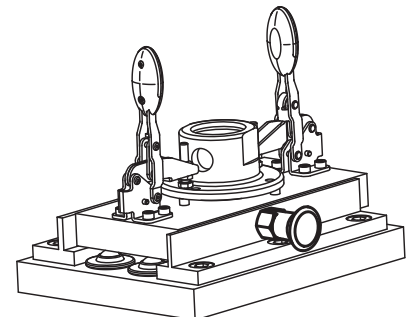

Indexing Plungers

pull knob



KIPP Indexing plungers, steel, indexing pin hardened, inch

Item No. Style A	Item No. Style B	Item No. Style C	Item No. Style D	D	D1	D2	L	L1	L2	L3	H	SW1	SW2	F x 30°	Spring force initial pressure F1 approx. N	Spring force final pressure F2 approx. N
K0338.1903AJ84	K0338.2903AJ84	K0338.3903AJ84	K0338.4903AJ84	3	1/4-28	14	31,5	12	5	10	3,5	8	-7/16/-7/16	0,8	4,5	10
K0338.1004AK84	K0338.2004AK84	K0338.3004AK84	K0338.4004AK84	4	5/16-24	18	38,5	15	6	13	4	10	-1/2/-1/2	1	6	12
K0338.1105AL84	K0338.2105AL84	K0338.3105AL84	K0338.4105AL84	5	3/8-24	21	43,5	17	7	15	5	13	-9/16/-9/16	1,3	5	12
K0338.1206A584	K0338.2206A584	K0338.3206A584	K0338.4206A584	6	1/2-13	25	51,7	20	8	16	6	14	-3/4/-3/4	1,8	6	14
K0338.1308A684	K0338.2308A684	K0338.3308A684	K0338.4308A684	8	5/8-11	33	68	26	10	21	8	19	-15/16/-15/16	2,3	15	35
K0338.1410A784	K0338.2410A784	K0338.3410A784	K0338.4410A784	10	3/4-10	33	74	28	12	23	10	22	-1,125/-1,125	2,8	15	40
K0338.1412A084	K0338.2412A084	K0338.3412A084	K0338.4412A084	12	3/4-16	33	78	28	14	25	12	22	-1,125/-1,125	2,8	15	39
K0338.1516A884	K0338.2516A884	K0338.3516A884	K0338.4516A884	16	1-8	40	96	32	18	28	16	27	-1,5/-1,5	3,2	20	46

KIPP Indexing plungers, stainless steel, indexing pin hardened, inch

Item No. Style A	Item No. Style B	Item No. Style C	Item No. Style D	D	D1	D2	L	L1	L2	L3	H	SW1	SW2	F x 30°	Spring force initial pressure F1 approx. N	Spring force final pressure F2 approx. N
K0338.01903AJ84	K0338.02903AJ84	K0338.03903AJ84	K0338.04903AJ84	3	1/4-28	14	31,5	12	5	10	3,5	8	-7/16/-7/16	0,8	4,5	10
K0338.01004AK84	K0338.02004AK84	K0338.03004AK84	K0338.04004AK84	4	5/16-24	18	38,5	15	6	13	4	10	-1/2/-1/2	1	6	12
K0338.01105AL84	K0338.02105AL84	K0338.03105AL84	K0338.04105AL84	5	3/8-24	21	43,5	17	7	15	5	13	-9/16/-9/16	1,3	5	12
K0338.01206A584	K0338.02206A584	K0338.03206A584	K0338.04206A584	6	1/2-13	25	51,7	20	8	16	6	14	-3/4/-3/4	1,8	6	14
K0338.01308A684	K0338.02308A684	K0338.03308A684	K0338.04308A684	8	5/8-11	33	68	26	10	21	8	19	-15/16/-15/16	2,3	15	35
K0338.01410A784	K0338.02410A784	K0338.03410A784	K0338.04410A784	10	3/4-10	33	74	28	12	23	10	22	-1,125/-1,125	2,8	15	40
K0338.01412A084	K0338.02412A084	K0338.03412A084	K0338.04412A084	12	3/4-16	33	78	28	14	25	12	22	-1,125/-1,125	2,8	15	39
K0338.01516A884	K0338.02516A884	K0338.03516A884	K0338.04516A884	16	1-8	40	96	32	18	28	16	27	-1,5/-1,5	3,2	20	46

KIPP Indexing plungers, stainless steel, indexing pin not hardened, inch

Item No. Style A	Item No. Style B	Item No. Style C	Item No. Style D	D	D1	D2	L	L1	L2	L3	H	SW1	SW2	F x 30°	Spring force initial pressure F1 approx. N	Spring force final pressure F2 approx. N
K0338.11903AJ84	K0338.12903AJ84	K0338.13903AJ84	K0338.14903AJ84	3	1/4-28	14	31,5	12	5	10	3,5	8	-7/16/-7/16	0,8	4,5	10
K0338.11004AK84	K0338.12004AK84	K0338.13004AK84	K0338.14004AK84	4	5/16-24	18	38,5	15	6	13	4	10	-1/2/-1/2	1	6	12
K0338.11105AL84	K0338.12105AL84	K0338.13105AL84	K0338.14105AL84	5	3/8-24	21	43,5	17	7	15	5	13	-9/16/-9/16	1,3	5	12
K0338.11206A584	K0338.12206A584	K0338.13206A584	K0338.14206A584	6	1/2-13	25	51,7	20	8	16	6	14	-3/4/-3/4	1,8	6	14
K0338.11308A684	K0338.12308A684	K0338.13308A684	K0338.14308A684	8	5/8-11	33	68	26	10	21	8	19	-15/16/-15/16	2,3	15	35
K0338.11410A784	K0338.12410A784	K0338.13410A784	K0338.14410A784	10	3/4-10	33	74	28	12	23	10	22	-1,125/-1,125	2,8	15	40
K0338.11412A084	K0338.12412A084	K0338.13412A084	K0338.14412A084	12	3/4-16	33	78	28	14	25	12	22	-1,125/-1,125	2,8	15	39
K0338.11516A884	K0338.12516A884	K0338.13516A884	K0338.14516A884	16	1-8	40	96	32	18	28	16	27	-1,5/-1,5	3,2	20	46

Indexing Plungers

pull knob

METRIC
Parts

New Item



Style A
non-lockout type
without locknut

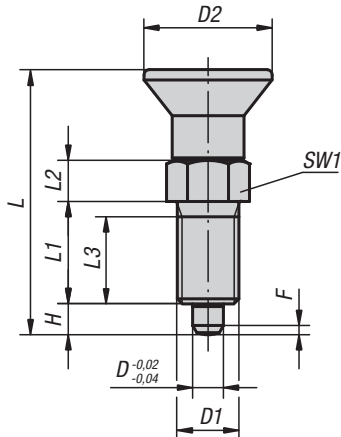

Style B
non-lockout type
with locknut

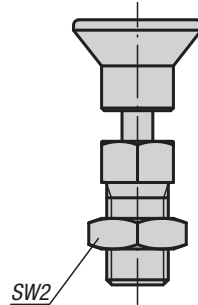

Style C
lockout type
without locknut

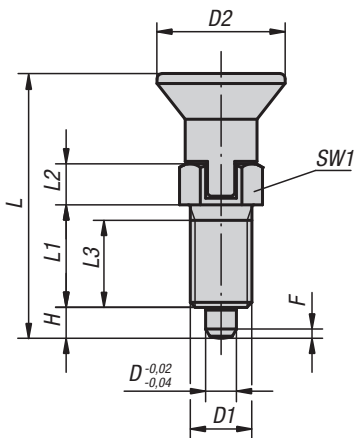

Style D
lockout type
with locknut

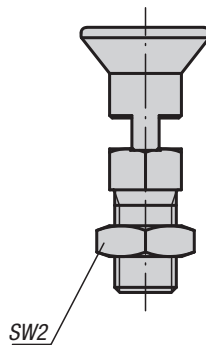

Material:

- Steel version, locking pin hardened: quality class 5.8
- Stainless steel version, locking pin hardened: threaded sleeve 1.4305 locking pin 1.4034
- Stainless steel version, locking pin not hardened: threaded sleeve 1.4305 locking pin 1.4305

Mushroom knob in red thermoplastic

Type:

- Steel version, locking pin hardened: black oxide finish, locking pin ground
- Stainless steel version, locking pin hardened: natural finish, locking pin ground
- Stainless steel version, locking pin not hardened: natural finish, locking pin ground

Order information:

K0338.0420684

Note:

Indexing Plungers are used to prevent any change in locking position due to lateral forces. A new locking position can only be set after the bolt has been manually disengaged. Style C or D is recommended for applications in which gradual disengagement of the locking bolt is desired where a springing back of the pin should be prevented.

On request:

Special versions.

Accessories:

Spacer rings K0665

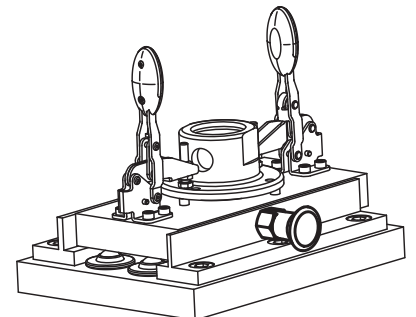

Indexing Plungers

pull knob



KIPP Indexing plungers, steel, indexing pin hardened, metric

Item No. Style A	Item No. Style B	Item No. Style C	Item No. Style D	D	D1	D2	L	L1	L2	L3	H	SW1	SW2	F x 30°	Spring force initial pressure F1 approx. N	Spring force final pressure F2 approx. N
K0338.190384	K0338.290384	K0338.390384	K0338.490384	3	M6x0,75	14	31,5	12	5	10	3,5	8	-/10-/10	0,8	4,5	10
K0338.100484	K0338.200484	K0338.300484	K0338.400484	4	M8x1	18	38,5	15	6	13	4	10	-/13-/13	1	6	12
K0338.110584	K0338.210584	K0338.310584	K0338.410584	5	M10x1	21	43,5	17	7	15	5	13	-/17-/17	1,3	5	12
K0338.120684	K0338.220684	K0338.320684	K0338.420684	6	M12x1,5	25	51,7	20	8	17	6	14	-/19-/19	1,8	6	14
K0338.130884	K0338.230884	K0338.330884	K0338.430884	8	M16x1,5	33	68	26	10	23	8	19	-/24-/24	2,3	15	35
K0338.141084	K0338.241084	K0338.341084	K0338.441084	10	M20x1,5	33	74	28	12	25	10	22	-/30-/30	2,8	15	34
K0338.141284	K0338.241284	K0338.341284	K0338.441284	12	M20x1,5	33	78	28	14	25	12	22	-/30-/30	2,8	15	39
K0338.151684	K0338.251684	K0338.351684	K0338.451684	16	M24x2	40	96	32	18	28	16	27	-/36-/36	3,2	20	46

KIPP Indexing plungers, stainless steel, indexing pin hardened, metric

Item No. Style A	Item No. Style B	Item No. Style C	Item No. Style D	D	D1	D2	L	L1	L2	L3	H	SW1	SW2	F x 30°	Spring force initial pressure F1 approx. N	Spring force final pressure F2 approx. N
K0338.0190384	K0338.0290384	K0338.0390384	K0338.0490384	3	M6x0,75	14	31,5	12	5	10	3,5	8	-/10-/10	0,8	4,5	10
K0338.0100484	K0338.0200484	K0338.0300484	K0338.0400484	4	M8x1	18	38,5	15	6	13	4	10	-/13-/13	1	6	12
K0338.0110584	K0338.0210584	K0338.0310584	K0338.0410584	5	M10x1	21	43,5	17	7	15	5	13	-/17-/17	1,3	5	12
K0338.0120684	K0338.0220684	K0338.0320684	K0338.0420684	6	M12x1,5	25	51,7	20	8	17	6	14	-/19-/19	1,8	6	14
K0338.0130884	K0338.0230884	K0338.0330884	K0338.0430884	8	M16x1,5	33	68	26	10	23	8	19	-/24-/24	2,3	15	35
K0338.0141084	K0338.0241084	K0338.0341084	K0338.0441084	10	M20x1,5	33	74	28	12	25	10	22	-/30-/30	2,8	15	34
K0338.0141284	K0338.0241284	K0338.0341284	K0338.0441284	12	M20x1,5	33	78	28	14	25	12	22	-/30-/30	2,8	15	39
K0338.0151684	K0338.0251684	K0338.0351684	K0338.0451684	16	M24x2	40	96	32	18	28	16	27	-/36-/36	3,2	20	46

KIPP Indexing plungers, stainless steel, indexing pin not hardened, metric

Item No. Style A	Item No. Style B	Item No. Style C	Item No. Style D	D	D1	D2	L	L1	L2	L3	H	SW1	SW2	F x 30°	Spring force initial pressure F1 approx. N	Spring force final pressure F2 approx. N
K0338.1100484	K0338.1200484	K0338.1300484	K0338.1400484	4	M8x1	18	38,5	15	6	13	4	10	-/13-/13	1	6	12
K0338.1190384	K0338.1290384	K0338.1390384	K0338.1490384	3	M6x0,75	14	31,5	12	5	10	3,5	8	-/10-/10	0,8	4,5	10
K0338.1110584	K0338.1210584	K0338.1310584	K0338.1410584	5	M10x1	21	43,5	17	7	15	5	13	-/17-/17	1,3	5	12
K0338.1120684	K0338.1220684	K0338.1320684	K0338.1420684	6	M12x1,5	25	51,7	20	8	17	6	14	-/19-/19	1,8	6	14
K0338.1130884	K0338.1230884	K0338.1330884	K0338.1430884	8	M16x1,5	33	68	26	10	23	8	19	-/24-/24	2,3	15	35
K0338.1141084	K0338.1241084	K0338.1341084	K0338.1441084	10	M20x1,5	33	74	28	12	25	10	22	-/30-/30	2,8	15	34
K0338.1141284	K0338.1241284	K0338.1341284	K0338.1441284	12	M20x1,5	33	78	28	14	25	12	22	-/30-/30	2,8	15	39
K0338.1151684	K0338.1251684	K0338.1351684	K0338.1451684	16	M24x2	40	96	32	18	28	16	27	-/36-/36	3,2	20	46

Indexing Plungers

pull knob, with extended locking pin

INCH
Parts



Style A
non-lockout type
without locknut

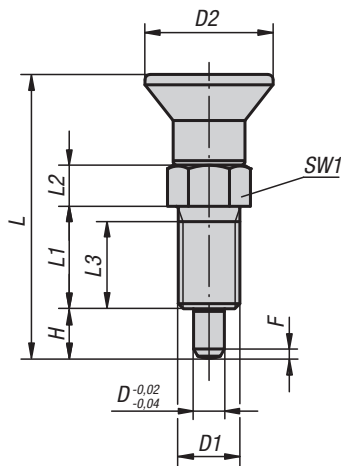

Style B
non-lockout type
with locknut

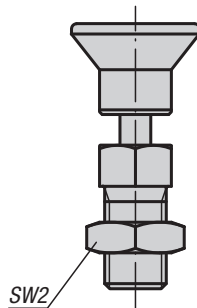

Material:

- Steel version, locking pin hardened: quality class 5.8
- Stainless steel version, locking pin hardened: threaded sleeve 1.4305 locking pin 1.4034
- Stainless steel version, locking pin not hardened: threaded sleeve 1.4305 locking pin 1.4305

Mushroom knob in black gray thermoplastic

Type:

- Steel version, locking pin hardened: black oxide finish, locking pin ground
- Stainless steel version, locking pin hardened: natural finish, locking pin ground
- Stainless steel version, locking pin not hardened: natural finish, locking pin ground

Part Number Example:

K0630.21903AJ

Note:

Indexing plungers are used to prevent any change in locking position due to lateral forces. A new locking position can only be set after the pin has been manually disengaged.

On request:

Special versions and spacer rings.

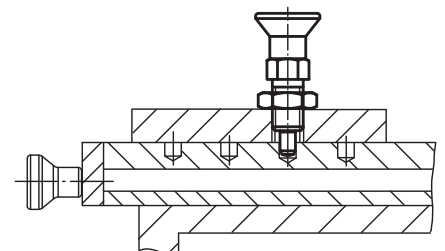

Indexing Plungers

pull knob, with extended locking pin

KIPP Indexing Plungers with extended locking pin, pull knob, steel, locking pin hardened, inch

Item No. Style A	Item No. Style B	D	D1	D2	L	L1	L2	L3	H	SW1	SW2	F x 30°	Spring force initial pressure F1 approx. N	Spring force final pressure F2 approx. N
K0630.21903AJ	K0630.22903AJ	3	1/4-28	14	33	12	5	10	5	8	- 7/16	0,8	4,5	12
K0630.21004AK	K0630.22004AK	4	5/16-24	18	40,5	15	6	13	6	10	- 1/2	1	6	15
K0630.21105AL	K0630.22105AL	5	3/8-24	21	46,5	17	7	15	8	13	- 9/16	1,3	5	16
K0630.21206A5	K0630.22206A5	6	1/2-13	25	55	20	8	17	9	14	- 3/4	1,8	6	18
K0630.21308A6	K0630.22308A6	8	5/8-11	33	72	26	10	23	12	19	- 15/16	2,3	15	45
K0630.21410A7	K0630.22410A7	10	3/4-10	33	79	28	12	25	15	22	- 11/8	2,8	15	43
K0630.21412A0	K0630.22412A0	12	3/4-16	33	84	28	14	25	18	22	- 11/8	2,8	15	51
K0630.21516A8	K0630.22516A8	16	1-8	40	104	32	18	28	24	27	- 11/2	3,2	20	60

KIPP Indexing Plungers with extended locking pin, pull knob, stainless steel, locking pin hardened, inch

Item No. Style A	Item No. Style B	D	D1	D2	L	L1	L2	L3	H	SW1	SW2	F x 30°	Spring force initial pressure F1 approx. N	Spring force final pressure F2 approx. N
K0630.201903AJ	K0630.202903AJ	3	1/4-28	14	33	12	5	10	5	8	- 7/16	0,8	4,5	12
K0630.201004AK	K0630.202004AK	4	5/16-24	18	40,5	15	6	13	6	10	- 1/2	1	6	15
K0630.201105AL	K0630.202105AL	5	3/8-24	21	46,5	17	7	15	8	13	- 9/16	1,3	5	16
K0630.201206A5	K0630.202206A5	6	1/2-13	25	55	20	8	17	9	14	- 3/4	1,8	6	18
K0630.201308A6	K0630.202308A6	8	5/8-11	33	72	26	10	23	12	19	- 15/16	2,3	15	45
K0630.201410A7	K0630.202410A7	10	3/4-10	33	79	28	12	25	15	22	- 11/8	2,8	15	43
K0630.201412A0	K0630.202412A0	12	3/4-16	33	84	28	14	25	18	22	- 11/8	2,8	15	51
K0630.201516A8	K0630.202516A8	16	1-8	40	104	32	18	28	24	27	- 11/2	3,2	20	60

KIPP Indexing Plungers with extended locking pin, pull knob, stainless steel, locking pin not hardened, inch

Item No. Style A	Item No. Style B	D	D1	D2	L	L1	L2	L3	H	SW1	SW2	F x 30°	Spring force initial pressure F1 approx. N	Spring force final pressure F2 approx. N
K0630.211903AJ	K0630.212903AJ	3	1/4-28	14	33	12	5	10	5	8	- 7/16	0,8	4,5	12
K0630.211004AK	K0630.212004AK	4	5/16-24	18	40,5	15	6	13	6	10	- 1/2	1	6	15
K0630.211105AL	K0630.212105AL	5	3/8-24	21	46,5	17	7	15	8	13	- 9/16	1,3	5	16
K0630.211206A5	K0630.212206A5	6	1/2-13	25	55	20	8	17	9	14	- 3/4	1,8	6	18
K0630.211308A6	K0630.212308A6	8	5/8-11	33	72	26	10	23	12	19	- 15/16	2,3	15	45
K0630.211410A7	K0630.212410A7	10	3/4-10	33	79	28	12	25	15	22	- 11/8	2,8	15	43
K0630.211412A0	K0630.212412A0	12	3/4-16	33	84	28	14	25	18	22	- 11/8	2,8	15	51
K0630.211516A8	K0630.212516A8	16	1-8	40	104	32	18	28	24	27	- 11/2	3,2	20	60

Indexing Plungers

pull knob, with extended locking pin

METRIC
Parts



Style A
non-lockout type
without locknut

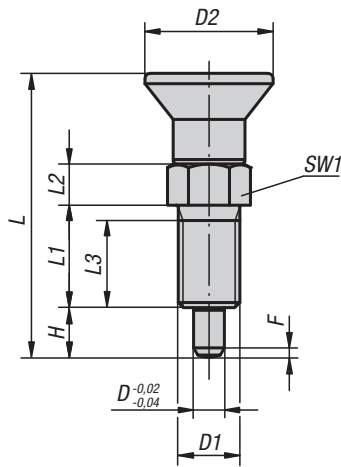

Style B
non-lockout type
with locknut

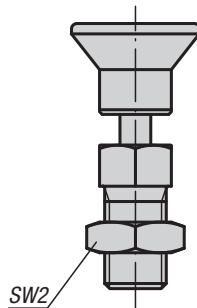

Material:

- Steel version, locking pin hardened: quality class 5.8
- Stainless steel version, locking pin hardened: threaded sleeve 1.4305 locking pin 1.4034
- Stainless steel version, locking pin not hardened: threaded sleeve 1.4305 locking pin 1.4305

Mushroom knob in black gray thermoplastic

Type:

- Steel version, locking pin hardened: black oxide finish, locking pin ground
- Stainless steel version, locking pin hardened: natural finish, locking pin ground
- Stainless steel version, locking pin not hardened: natural finish, locking pin ground

Part Number Example:

K0630.21903AJ

Note:

Indexing plungers are used to prevent any change in locking position due to lateral forces. A new locking position can only be set after the pin has been manually disengaged.

On request:

Special versions and spacer rings.

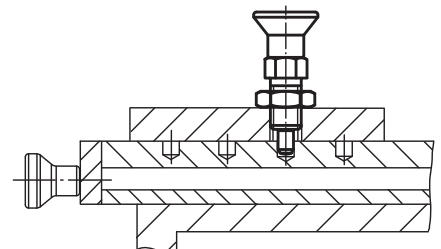

Indexing Plungers

pull knob, with extended locking pin

KIPP Indexing Plungers with extended locking pin, pull knob, steel, locking pin hardened, metric

Item No. Style A	Item No. Style B	D	D1	D2	L	L1	L2	L3	H	SW1	SW2	F x 30°	Spring force initial pressure F1 approx. N	Spring force final pressure F2 approx. N
K0630.21903	K0630.22903	3	M6x0,75	14	33	12	5	10	5	8	- / 10	0,8	4,5	12
K0630.21004	K0630.22004	4	M8x1	18	40,5	15	6	13	6	10	- / 13	1	6	15
K0630.21105	K0630.22105	5	M10x1	21	46,5	17	7	15	8	13	- / 17	1,3	5	16
K0630.21206	K0630.22206	6	M12x1,5	25	54,7	20	8	17	9	14	- / 19	1,8	6	18
K0630.21308	K0630.22308	8	M16x1,5	33	72	26	10	23	12	19	- / 24	2,3	15	45
K0630.21410	K0630.22410	10	M20x1,5	33	79	28	12	25	15	22	- / 30	2,8	15	43
K0630.21412	K0630.22412	12	M20x1,5	33	84	28	14	25	18	22	- / 30	2,8	15	51
K0630.21516	K0630.22516	16	M24x2	40	104	32	18	28	24	27	- / 36	3,2	20	60

KIPP Indexing Plungers with extended locking pin, pull knob, stainless steel, locking pin hardened, metric

Item No. Style A	Item No. Style B	D	D1	D2	L	L1	L2	L3	H	SW1	SW2	F x 30°	Spring force initial pressure F1 approx. N	Spring force final pressure F2 approx. N
K0630.201903	K0630.202903	3	M6x0,75	14	33	12	5	10	5	8	- / 10	0,8	4,5	12
K0630.201004	K0630.202004	4	M8x1	18	40,5	15	6	13	6	10	- / 13	1	6	15
K0630.201105	K0630.202105	5	M10x1	21	46,5	17	7	15	8	13	- / 17	1,3	5	16
K0630.201206	K0630.202206	6	M12x1,5	25	54,7	20	8	17	9	14	- / 19	1,8	6	18
K0630.201308	K0630.202308	8	M16x1,5	33	72	26	10	23	12	19	- / 24	2,3	15	45
K0630.201410	K0630.202410	10	M20x1,5	33	79	28	12	25	15	22	- / 30	2,8	15	43
K0630.201412	K0630.202412	12	M20x1,5	33	84	28	14	25	18	22	- / 30	2,8	15	51
K0630.201516	K0630.202516	16	M24x2	40	104	32	18	28	24	27	- / 36	3,2	20	60

KIPP Indexing Plungers with extended locking pin, pull knob, stainless steel, locking pin not hardened, metric

Item No. Style A	Item No. Style B	D	D1	D2	L	L1	L2	L3	H	SW1	SW2	F x 30°	Spring force initial pressure F1 approx. N	Spring force final pressure F2 approx. N
K0630.211903	K0630.212903	3	M6x0,75	14	33	12	5	10	5	8	- / 10	0,8	4,5	12
K0630.211004	K0630.212004	4	M8x1	18	40,5	15	6	13	6	10	- / 13	1	6	15
K0630.211105	K0630.212105	5	M10x1	21	46,5	17	7	15	8	13	- / 17	1,3	5	16
K0630.211206	K0630.212206	6	M12x1,5	25	54,7	20	8	17	9	14	- / 19	1,8	6	18
K0630.211308	K0630.212308	8	M16x1,5	33	72	26	10	23	12	19	- / 24	2,3	15	45
K0630.211410	K0630.212410	10	M20x1,5	33	79	28	12	25	15	22	- / 30	2,8	15	43
K0630.211412	K0630.212412	12	M20x1,5	33	84	28	14	25	18	22	- / 30	2,8	15	51
K0630.211516	K0630.212516	16	M24x2	40	104	32	18	28	24	27	- / 36	3,2	20	60

Indexing Plungers

pull knob, short version

INCH Parts METRIC Parts



Style A
non-lockout type
without locknut

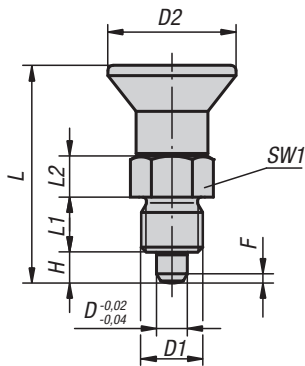

Style B
non-lockout type
with locknut

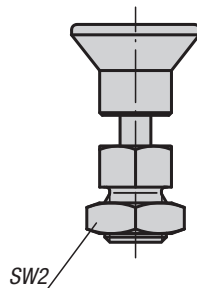

Style C
lockout type
without locknut

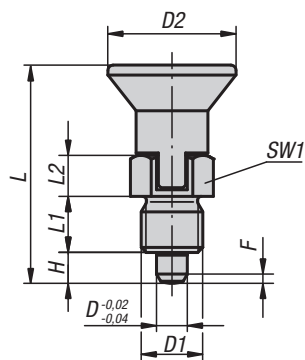

Style D
lockout type
with locknut

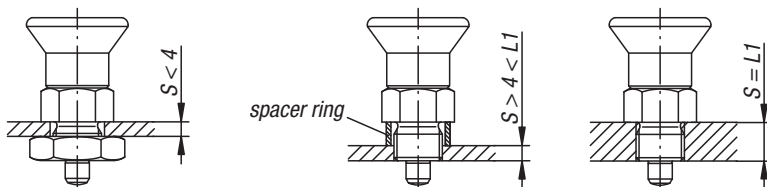
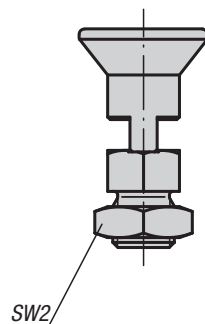

Material:

- Steel version, locking pin hardened: quality class 5.8
- Stainless steel version, locking pin not hardened: threaded sleeve 1.4305 locking pin 1.4305

Mushroom knob black gray thermoplastic.

Type:

- Steel version, locking pin hardened: black oxide finish, locking pin ground
- Stainless steel version, locking pin not hardened: natural finish, locking pin ground

Part Number Example:

K0631.5004AK

Note:

Indexing plungers are used to prevent any change in position due to lateral forces. A new locking position can only be set after the pin has been manually disengaged. Style C or D is recommended for applications in which the pin is disengaged over extended periods and should be prevented from springing back.

On request:

Special versions and spacer rings.

Indexing Plungers

pull knob, short version



KIPP Indexing Plungers short version, pull knob, steel, locking pin hardened, inch

Item No. Style A	Item No. Style B	Item No. Style C	Item No. Style D	D	D1	D2	L	L1	L2	H	SW1	SW2	F x 30°	Spring force initial pressure F1 approx. N	Spring force final pressure F2 approx. N
K0631.5004AK	K0631.6004AK	K0631.7004AK	K0631.8004AK	4	5/16-24	18	29,5	6	6	4	10	-1 1/2 -1 1/2	1	6	12
K0631.5105AL	K0631.6105AL	K0631.7105AL	K0631.8105AL	5	3/8-24	21	34,5	8	7	5	13	-1 9/16 -1 9/16	1,3	5	12
K0631.5206A5	K0631.6206A5	K0631.7206A5	K0631.8206A5	6	1/2-13	25	41,7	10	8	6	14	-1 3/4 -1 3/4	1,8	6	14
K0631.5308A6	K0631.6308A6	K0631.7308A6	K0631.8308A6	8	5/8-11	33	54	12	10	8	19	-1 15/16 -1 15/16	2,3	14	28
K0631.5410A7	K0631.6410A7	K0631.7410A7	K0631.8410A7	10	3/4-10	33	61	15	12	10	22	-1 1,125 -1 1,125	2,8	15	32

KIPP Indexing Plungers, short version, pull knob, stainless steel, locking pin not hardened, inch

Item No. Style A	Item No. Style B	Item No. Style C	Item No. Style D	D	D1	D2	L	L1	L2	H	SW1	SW2	F x 30°	Spring force initial pressure F1 approx. N	Spring force final pressure F2 approx. N
K0631.15004AK	K0631.16004AK	K0631.17004AK	K0631.18004AK	4	5/16-24	18	29,5	6	6	4	10	-1 1/2 -1 1/2	1	6	12
K0631.15105AL	K0631.16105AL	K0631.17105AL	K0631.18105AL	5	3/8-24	21	34,5	8	7	5	13	-1 9/16 -1 9/16	1,3	5	12
K0631.15206A5	K0631.16206A5	K0631.17206A5	K0631.18206A5	6	1/2-13	25	41,7	10	8	6	14	-1 3/4 -1 3/4	1,8	6	14
K0631.15308A6	K0631.16308A6	K0631.17308A6	K0631.18308A6	8	5/8-11	33	54	12	10	8	19	-1 15/16 -1 15/16	2,3	14	28
K0631.15410A7	K0631.16410A7	K0631.17410A7	K0631.18410A7	10	3/4-10	33	61	15	12	10	22	-1 1,125 -1 1,125	2,8	15	32

KIPP Indexing Plungers short version, pull knob, steel, locking pin hardened, metric

Item No. Style A	Item No. Style B	Item No. Style C	Item No. Style D	D	D1	D2	L	L1	L2	H	SW1	SW2	F x 30°	Spring force initial pressure F1 approx. N	Spring force final pressure F2 approx. N
K0631.5903	K0631.6903	K0631.7903	K0631.8903	3	M6x0,75	14	25,5	6	5	3,5	8	-10/-10	0,8	4	10
K0631.5004	K0631.6004	K0631.7004	K0631.8004	4	M8x1	18	29,5	6	6	4	10	-13/-13	1	4	12
K0631.5105	K0631.6105	K0631.7105	K0631.8105	5	M10x1	21	34,5	8	7	5	13	-17/-17	1,3	5	12
K0631.5206	K0631.6206	K0631.7206	K0631.8206	6	M12x1,5	25	41,7	10	8	6	14	-19/-19	1,8	6	14
K0631.5308	K0631.6308	K0631.7308	K0631.8308	8	M16x1,5	33	54	12	10	8	19	-24/-24	2,3	14	28
K0631.5410	K0631.6410	K0631.7410	K0631.8410	10	M20x1,5	33	61	15	12	10	22	-30/-30	2,8	15	32

KIPP Indexing Plungers, short version, pull knob, stainless steel, locking pin not hardened, metric

Item No. Style A	Item No. Style B	Item No. Style C	Item No. Style D	D	D1	D2	L	L1	L2	H	SW1	SW2	F x 30°	Spring force initial pressure F1 approx. N	Spring force final pressure F2 approx. N
K0631.15903	K0631.16903	K0631.17903	K0631.18903	3	M6x0,75	14	25,5	6	5	3,5	8	-10/-10	0,8	4	10
K0631.15004	K0631.16004	K0631.17004	K0631.18004	4	M8x1	18	29,5	6	6	4	10	-13/-13	1	4	12
K0631.15105	K0631.16105	K0631.17105	K0631.18105	5	M10x1	21	34,5	8	7	5	13	-17/-17	1,3	5	12
K0631.15206	K0631.16206	K0631.17206	K0631.18206	6	M12x1,5	25	41,7	10	8	6	14	-19/-19	1,8	6	14
K0631.15308	K0631.16308	K0631.17308	K0631.18308	8	M16x1,5	33	54	12	10	8	19	-24/-24	2,3	14	28
K0631.15410	K0631.16410	K0631.17410	K0631.18410	10	M20x1,5	33	61	15	12	10	22	-30/-30	2,8	15	32

Indexing Plungers

pull knob, stainless steel



Style A
non-lockout type
without locknut

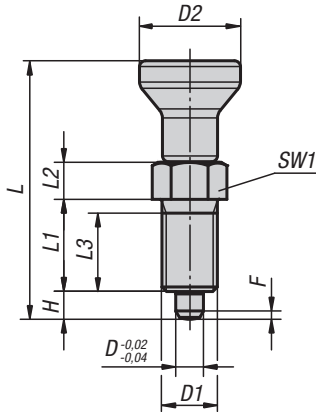

Style B
non-lockout type
with locknut

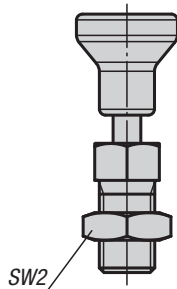

Style C
lockout type
without locknut

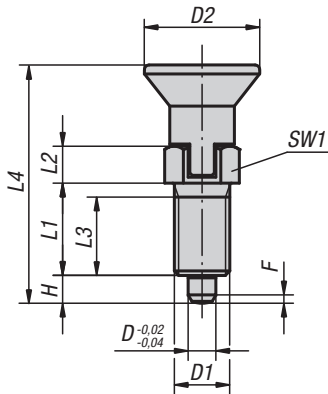

Style D
lockout type
with locknut

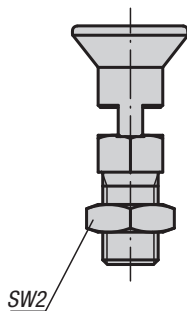

Material:

- Locking pin hardened:
threaded sleeve 1.4305
locking pin 1.4034
- Locking pin not hardened:
threaded sleeve 1.4305
locking pin 1.4305

Mushroom knob 1.4305, electrolytic-polish

Type:

Natural finish; locking pin ground

Part Number Example:

K0632.001903AJ

Note:

Indexing plungers are used to prevent any change in locking position due to lateral forces. A new locking position can only be set after the pin has been manually disengaged.

Style C or D is recommended for applications in which the pin is disengaged over extended periods and should be prevented from springing back.

On request:

Special versions.

KIPP Measurements, Indexing Plungers pull knob, stainless steel

D	D2	L1	L2	L3	H	SW1	Spring force initial pressure F1 approx. N	Spring force final pressure F2 approx. N
3	14	12	5	10	3,5	8	4,5	10
4	18	15	6	13	4	10	6	12
5	21	17	7	15	5	13	4,5	12
6	25	20	8	17	6	14	6	14
8	33	26	10	23	8	19	15	35
10	33	28	12	25	10	22	15	34
12	33	28	14	25	12	22	15	39
16	40	32	18	28	16	27	20	46

KIPP Indexing Plungers, pull knob, stainless steel, locking pin hardened, inch

Item No. Style A	Item No. Style B	Item No. Style C	Item No. Style D	D1	L	L4	SW2	F x 30°
K0632.001903AJ	K0632.002903AJ	K0632.003903AJ	K0632.004903AJ	1/4-28	34,5/34,5/-/-	-/-/31,5/31,5	- 7/16 - 7/16	0,8
K0632.001004AK	K0632.002004AK	K0632.003004AK	K0632.004004AK	5/16-24	43/43/-/-	-/-/38,5/38,5	- 1/2 - 1/2	1
K0632.001105AL	K0632.002105AL	K0632.003105AL	K0632.004105AL	3/8-24	50/50/-/-	-/-/43,5/43,5	- 9/16 - 9/16	1,3
K0632.001206A5	K0632.002206A5	K0632.003206A5	K0632.004206A5	1/2-13	59/59/-/-	-/-/52/52	- 3/4 - 3/4	1,8
K0632.001308A6	K0632.002308A6	K0632.003308A6	K0632.004308A6	5/8-11	77/77/-/-	-/-/68/68	- 15/16 - 15/16	2,3
K0632.001410A7	K0632.002410A7	K0632.003410A7	K0632.004410A7	3/4-10	83/83/-/-	-/-/74/74	- 1,125 - 1,125	2,6
K0632.001412A0	K0632.002412A0	K0632.003412A0	K0632.004412A0	3/4-16	87/87/-/-	-/-/78/78	- 1,125 - 1,125	2,8
K0632.001516A8	K0632.002516A8	K0632.003516A8	K0632.004516A8	1-8	106/106/-/-	-/-/96/96	- 1,5 - 1,5	3,2

KIPP Indexing Plungers, pull knob, stainless steel, locking pin not hardened, inch

Item No. Style A	Item No. Style B	Item No. Style C	Item No. Style D	D1	L	L4	SW2	F x 30°
K0632.111903AJ	K0632.112903AJ	K0632.113903AJ	K0632.114903AJ	1/4-28	34,5/34,5/-/-	-/-/31,5/31,5	- 7/16 - 7/16	0,8
K0632.111004AK	K0632.112004AK	K0632.113004AK	K0632.114004AK	5/16-24	43/43/-/-	-/-/38,5/38,5	- 1/2 - 1/2	1
K0632.111105AL	K0632.112105AL	K0632.113105AL	K0632.114105AL	3/8-24	50/50/-/-	-/-/43,5/43,5	- 9/16 - 9/16	1,3
K0632.111206A5	K0632.112206A5	K0632.113206A5	K0632.114206A5	1/2-13	59/59/-/-	-/-/52/52	- 3/4 - 3/4	1,8
K0632.111308A6	K0632.112308A6	K0632.113308A6	K0632.114308A6	5/8-11	77/77/-/-	-/-/68/68	- 15/16 - 15/16	2,3
K0632.111410A7	K0632.112410A7	K0632.113410A7	K0632.114410A7	3/4-10	83/83/-/-	-/-/74/74	- 1,125 - 1,125	2,6
K0632.111412A0	K0632.112412A0	K0632.113412A0	K0632.114412A0	3/4-16	87/87/-/-	-/-/78/78	- 1,125 - 1,125	2,8
K0632.111516A8	K0632.112516A8	K0632.113516A8	K0632.114516A8	1-8	106/106/-/-	-/-/96/96	- 1,5 - 1,5	3,2

KIPP Indexing Plungers, pull knob, stainless steel, locking pin hardened, metric

Item No. Style A	Item No. Style B	Item No. Style C	Item No. Style D	D1	L	L4	SW2	F x 30°
K0632.001903	K0632.002903	K0632.003903	K0632.004903	M6x0,75	34,5/34,5/-/-	-/-/31,5/31,5	- / 10 / - / 10	0,8
K0632.001004	K0632.002004	K0632.003004	K0632.004004	M8x1	43/43/-/-	-/-/38,5/38,5	- / 13 / - / 13	1
K0632.001105	K0632.002105	K0632.003105	K0632.004105	M10x1	50/50/-/-	-/-/43,5/43,5	- / 17 / - / 17	1,3
K0632.001206	K0632.002206	K0632.003206	K0632.004206	M12x1,5	59/59/-/-	-/-/51,7/51,7	- / 19 / - / 19	1,8
K0632.001308	K0632.002308	K0632.003308	K0632.004308	M16x1,5	77/77/-/-	-/-/68/68	- / 24 / - / 24	2,3
K0632.001410	K0632.002410	K0632.003410	K0632.004410	M20x1,5	83/83/-/-	-/-/74/74	- / 30 / - / 30	2,8
K0632.001412	K0632.002412	K0632.003412	K0632.004412	M20x1,5	87/87/-/-	-/-/78/78	- / 30 / - / 30	2,8
K0632.001516	K0632.002516	K0632.003516	K0632.004516	M24x2	106/106/-/-	-/-/96/96	- / 36 / - / 36	3,2

KIPP Indexing Plungers, pull knob, stainless steel, locking pin not hardened, metric

Item No. Style A	Item No. Style B	Item No. Style C	Item No. Style D	D1	L	L4	SW2	F x 30°
K0632.111903	K0632.112903	K0632.113903	K0632.114903	M6x0,75	34,5/34,5/-/-	-/-/31,5/31,5	- / 10 / - / 10	0,8
K0632.111004	K0632.112004	K0632.113004	K0632.114004	M8x1	43/43/-/-	-/-/38,5/38,5	- / 13 / - / 13	1
K0632.111105	K0632.112105	K0632.113105	K0632.114105	M10x1	50/50/-/-	-/-/43,5/43,5	- / 17 / - / 17	1,3
K0632.111206	K0632.112206	K0632.113206	K0632.114206	M12x1,5	59/59/-/-	-/-/51,7/51,7	- / 19 / - / 19	1,8
K0632.111308	K0632.112308	K0632.113308	K0632.114308	M16x1,5	77/77/-/-	-/-/68/68	- / 24 / - / 24	2,3
K0632.111410	K0632.112410	K0632.113410	K0632.114410	M20x1,5	83/83/-/-	-/-/74/74	- / 30 / - / 30	2,8
K0632.111412	K0632.112412	K0632.113412	K0632.114412	M20x1,5	87/87/-/-	-/-/78/78	- / 30 / - / 30	2,8
K0632.111516	K0632.112516	K0632.113516	K0632.114516	M24x2	106/106/-/-	-/-/96/96	- / 36 / - / 36	3,2

Indexing Plungers

pull knob



INCH Parts METRIC Parts

Style A
non-lockout type
without locknut

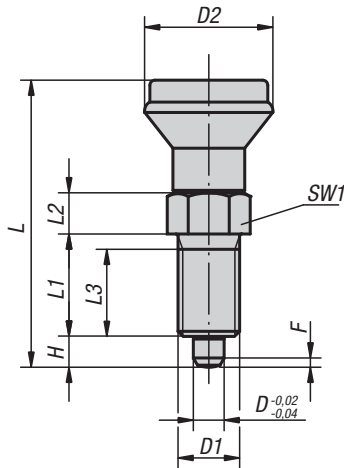

Style B
non-lockout type
with locknut

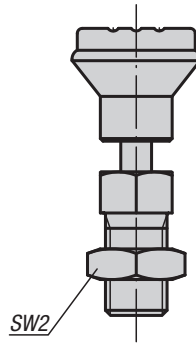

Style C
lockout type
without locknut

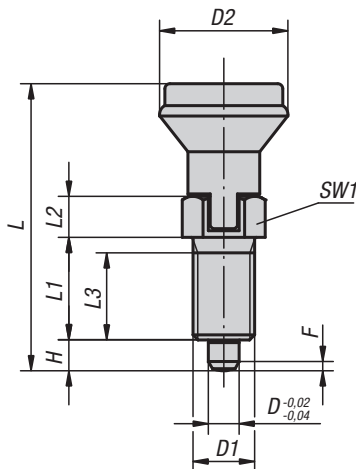

Style D
lockout type
with locknut

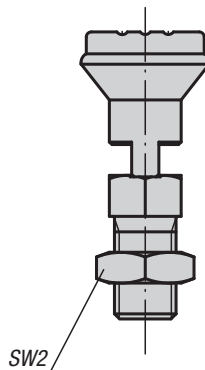

Material:

- Steel version, locking pin hardened: quality class 5.8
- Stainless steel version, locking pin hardened: threaded sleeve 1.4305 locking pin 1.4034
- Stainless steel version, locking pin not hardened: threaded sleeve 1.4305 locking pin 1.4305

Mushroom knob in black gray thermoplastic

Type:

- Steel version, locking pin hardened: black oxide finish, locking pin ground
- Stainless steel version, locking pin hardened: natural finish, locking pin ground
- Stainless steel version, locking pin not hardened: natural finish, locking pin ground

Part Number Example:

K0339.1005A4

Note:

Indexing plungers are used to prevent any change in locking position due to lateral forces. A new locking position can only be set after the pin has been manually disengaged.

Style C or D is recommended for applications in which the pin is disengaged over extended periods and should be prevented from springing back.

On request:

Special versions and spacer rings.

KIPP Indexing Plungers, pull knob, steel, locking pin hardened, inch

Item No. Style A	Item No. Style B	Item No. Style C	Item No. Style D	D	D1	D2	L	L1	L2	L3	H	SW1	SW2	F x 30°	Spring force initial pressure F1 approx. N	Spring force final pressure F2 approx. N
K0339.1005A4	K0339.2005A4	K0339.3005A4	K0339.4005A4	5	3/8-16	21	47	17	7	15	5	13	- 9/16 - 9/16	1,3	5	12
K0339.1105AL	K0339.2105AL	K0339.3105AL	K0339.4105AL	5	3/8-24	21	47	17	7	15	5	13	- 9/16 - 9/16	1,3	5	12
K0339.1206A5	K0339.2206A5	K0339.3206A5	K0339.4206A5	6	1/2-13	25	56	20	8	17	6	14	- 3/4 - 3/4	1,8	6	14
K0339.1308A6	K0339.2308A6	K0339.3308A6	K0339.4308A6	8	5/8-11	33	74	26	10	23	8	19	- 15/16 - 15/16	2,3	15	35
K0339.1410A7	K0339.2410A7	K0339.3410A7	K0339.4410A7	10	3/4-10	33	80	28	12	25	10	22	- 1,125 - 1,125	2,8	15	34

Indexing Plungers

pull knob

KIPP Indexing Plungers, pull knob, stainless steel, locking pin hardened, inch

Item No. Style A	Item No. Style B	Item No. Style C	Item No. Style D	D	D1	D2	L	L1	L2	L3	H	SW1	SW2	F x 30°	Spring force initial pressure F1 approx. N	Spring force final pressure F2 approx. N
K0339.01005A4	K0339.02005A4	K0339.03005A4	K0339.04005A4	5	3/8-16	21	47	17	7	15	5	13	- 9/16 - 9/16	1,3	5	12
K0339.01105AL	K0339.02105AL	K0339.03105AL	K0339.04105AL	5	3/8-24	21	47	17	7	15	5	13	- 9/16 - 9/16	1,3	5	12
K0339.01206A5	K0339.02206A5	K0339.03206A5	K0339.04206A5	6	1/2-13	25	56	20	8	17	6	14	- 3/4 - 3/4	1,8	6	14
K0339.01308A6	K0339.02308A6	K0339.03308A6	K0339.04308A6	8	5/8-11	33	74	26	10	23	8	19	- 15/16 - 15/16	2,3	15	35
K0339.01410A7	K0339.02410A7	K0339.03410A7	K0339.04410A7	10	3/4-10	33	80	28	12	25	10	22	- 1,125 - 1,125	2,8	15	34

KIPP Indexing Plungers, pull knob, stainless steel, locking pin not hardened, inch

Item No. Style A	Item No. Style B	Item No. Style C	Item No. Style D	D	D1	D2	L	L1	L2	L3	H	SW1	SW2	F x 30°	Spring force initial pressure F1 approx. N	Spring force final pressure F2 approx. N
K0339.11005A4	K0339.12005A4	K0339.13005A4	K0339.14005A4	5	3/8-16	21	47	17	7	15	5	13	- 9/16 - 9/16	1,3	5	12
K0339.11105AL	K0339.12105AL	K0339.13105AL	K0339.14105AL	5	3/8-24	21	47	17	7	15	5	13	- 9/16 - 9/16	1,3	5	12
K0339.11206A5	K0339.12206A5	K0339.13206A5	K0339.14206A5	6	1/2-13	25	56	20	8	17	6	14	- 3/4 - 3/4	1,8	6	14
K0339.11308A6	K0339.12308A6	K0339.13308A6	K0339.14308A6	8	5/8-11	33	74	26	10	23	8	19	- 15/16 - 15/16	2,3	15	35
K0339.11410A7	K0339.12410A7	K0339.13410A7	K0339.14410A7	10	3/4-10	33	80	28	12	25	10	22	- 1,125 - 1,125	2,8	15	34

KIPP Indexing Plungers, pull knob, steel, locking pin hardened, metric

Item No. Style A	Item No. Style B	Item No. Style C	Item No. Style D	D	D1	D2	L	L1	L2	L3	H	SW1	SW2	F x 30°	Spring force initial pressure F1 approx. N	Spring force final pressure F2 approx. N
K0339.1105	K0339.2105	K0339.3105	K0339.4105	5	M10x1	21	47	17	7	15	5	13	- 17 - 17	1,3	5	12
K0339.1206	K0339.2206	K0339.3206	K0339.4206	6	M12x1,5	25	56	20	8	17	6	14	- 19 - 19	1,8	6	14
K0339.1308	K0339.2308	K0339.3308	K0339.4308	8	M16x1,5	33	74	26	10	23	8	19	- 24 - 24	2,3	15	35
K0339.1410	K0339.2410	K0339.3410	K0339.4410	10	M20x1,5	33	80	28	12	25	10	22	- 30 - 30	2,8	15	34

KIPP Indexing Plungers, pull knob, stainless steel, locking pin hardened, metric

Item No. Style A	Item No. Style B	Item No. Style C	Item No. Style D	D	D1	D2	L	L1	L2	L3	H	SW1	SW2	F x 30°	Spring force initial pressure F1 approx. N	Spring force final pressure F2 approx. N
K0339.01105	K0339.02105	K0339.03105	K0339.04105	5	M10x1	21	47	17	7	15	5	13	- 17 - 17	1,3	5	12
K0339.01206	K0339.02206	K0339.03206	K0339.04206	6	M12x1,5	25	56	20	8	17	6	14	- 19 - 19	1,8	6	14
K0339.01308	K0339.02308	K0339.03308	K0339.04308	8	M16x1,5	33	74	26	10	23	8	19	- 24 - 24	2,3	15	35
K0339.01410	K0339.02410	K0339.03410	K0339.04410	10	M20x1,5	33	80	28	12	25	10	22	- 30 - 30	2,8	15	34

KIPP Indexing Plungers, pull knob, stainless steel, locking pin not hardened, metric

Item No. Style A	Item No. Style B	Item No. Style C	Item No. Style D	D	D1	D2	L	L1	L2	L3	H	SW1	SW2	F x 30°	Spring force initial pressure F1 approx. N	Spring force final pressure F2 approx. N
K0339.11105	K0339.12105	K0339.13105	K0339.14105	5	M10x1	21	47	17	7	15	5	13	- 17 - 17	1,3	5	12
K0339.11206	K0339.12206	K0339.13206	K0339.14206	6	M12x1,5	25	56	20	8	17	6	14	- 19 - 19	1,8	6	14
K0339.11308	K0339.12308	K0339.13308	K0339.14308	8	M16x1,5	33	74	26	10	23	8	19	- 24 - 24	2,3	15	35
K0339.11410	K0339.12410	K0339.13410	K0339.14410	10	M20x1,5	33	80	28	12	25	10	22	- 30 - 30	2,8	15	34

Indexing plunger

for thin-walled parts

New Item



Material:

- Steel version, locking pin hardened: quality class 5.8
- Stainless steel version, locking pin not hardened: threaded sleeve 1.4305 locking pin 1.4305

Mushroom knob black gray thermoplastic.

Type:

- Steel version, locking pin hardened: black oxide finish, locking pin ground
- Stainless steel version, locking pin not hardened: natural finish, locking pin ground

Part Number Example:

K0735.31105 (indexing plunger)
K0631.91416 (double-ended ring spanner)

Note:

These indexing plungers are especially well-suited for assembly in thin-walled parts. Indexing plungers are used where any change in locking position due to lateral forces should be prevented. A new locking position can be set only after the pin has been manually disengaged. Style C is recommended for applications where the locking pin should remain disengaged for an extended period and be prevented from springing back.

Accessories:

A double-ended ring spanner can be supplied as an accessory to tighten the nut.

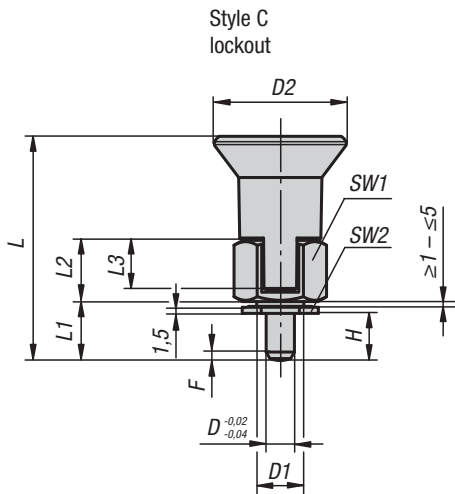
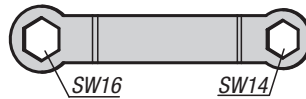
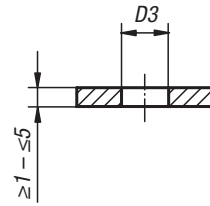
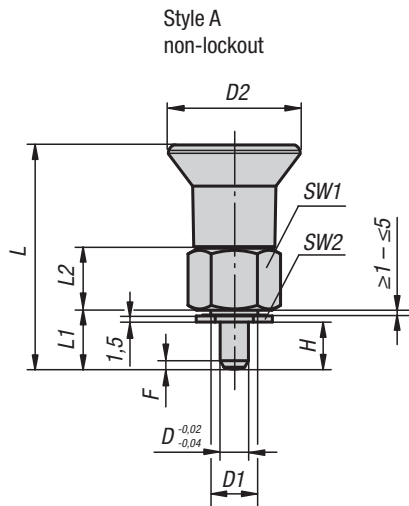

KIPP Indexing plungers for thin-walled parts, steel, indexing pin hardened, metric

Item No.	Style	D	D1	D2	D3	L	L1	L2	L3	H	SW1	SW2	F x 30°	Spring force initial pressure F1 approx. N	Spring force final pressure F2 approx. N	Article number double-ended ring spanner
K0735.31105	A	5	M10x1	28	10	46,5	11,5	13	10,5	5-9	17	14	1,3	6	15	K0631.91416
K0735.31206	A	6	M10x1	28	10	47,5	12,5	13	10,5	6-10	17	14	1,8	7	19	K0631.91416
K0735.33105	C	5	M10x1	28	10	46,5	11,5	13	10,5	5-9	17	14	1,3	6	15	K0631.91416
K0735.33206	C	6	M10x1	28	10	47,5	12,5	13	10,5	6-10	17	14	1,8	7	19	K0631.91416

KIPP Indexing plungers for thin-walled parts, stainless steel, indexing pin not hardened, metric

Item No.	Style	D	D1	D2	D3	L	L1	L2	L3	H	SW1	SW2	F x 30°	Spring force initial pressure F1 approx. N	Spring force final pressure F2 approx. N	Article number double-ended ring spanner
K0735.311105	A	5	M10x1	28	10	46,5	11,5	13	10,5	5-9	17	14	1,3	6	15	K0631.91416
K0735.311206	A	6	M10x1	28	10	47,5	12,5	13	10,5	6-10	17	14	1,8	7	19	K0631.91416
K0735.313105	C	5	M10x1	28	10	46,5	11,5	13	10,5	5-9	17	14	1,3	6	15	K0631.91416
K0735.313206	C	6	M10x1	28	10	47,5	12,5	13	10,5	6-10	17	14	1,8	7	19	K0631.91416

Indexing Plungers

INCH Parts METRIC Parts

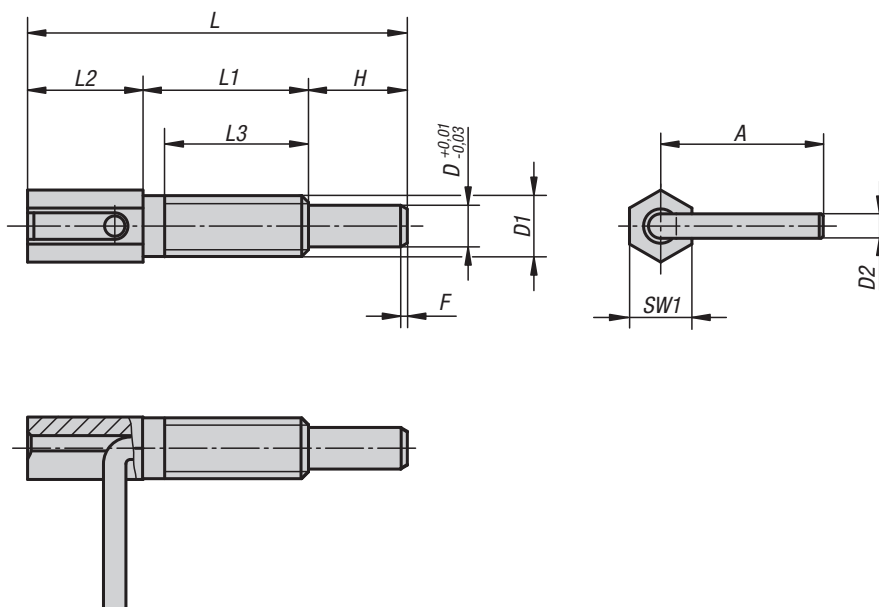

Material:
Steel quality class 5.8

Type:
Blue chromate.

Part Number Example:
K0340.11CWA2

Note:
Indexing plungers are used to prevent any change in locking position due to lateral forces. A new locking position can only be set after the pin has been manually disengaged.

On request:
Special versions.

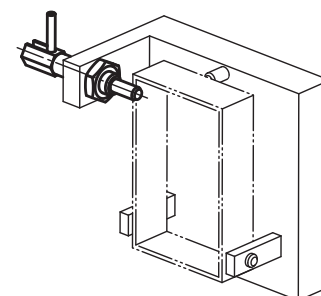

KIPP Indexing Plungers, inch (dimensions in inch)

Item No.	D	D1	D2	L	L1	L2	L3	H	A	SW1	F x 30°	Spring force initial pressure F1 approx. N	Spring force final pressure F2 approx. N	Max. tightening torque Nm
K0340.11CWA2	0,16	1/4-20	0,09	1,63	0,79	0,47	0,63	0,37	0,61	0,25	0,7	3	10	1,6
K0340.12CMA4	0,25	3/8-16	0,14	2,56	1,31	0,69	1,06	0,56	0,92	0,38	1,1	4	16	10
K0340.13CNA5	0,31	1/2-13	0,19	2,87	1,25	0,87	1,13	0,75	1,23	0,5	1,3	4	22	13
K0340.14COA6	0,38	5/8-11	0,19	4,05	1,99	1,06	1,75	1	1,29	0,63	1,6	4	23	42

KIPP Indexing Plungers, metric (dimensions in metric)

Item No.	D	D1	D2	L	L1	L2	L3	H	A	SW1	F x 30°	Spring force initial pressure F1 approx. N	Spring force final pressure F2 approx. N	Max. tightening torque Nm
K0340.1104	4	M6	2,3	41,5	20	12	17	9,5	15,5	6	0,7	3	10	1,6
K0340.1905	5	M8	3	54	27	15	24	12	19,2	8	0,9	3,5	13,5	4,5
K0340.1206	6	M10	3,5	65	33,5	17,5	30	14	22,9	10	1,1	4	16	10
K0340.1308	8	M12	4,7	73	31,8	22,2	28	19	31,2	12	1,3	4	22	13
K0340.1410	10	M16	4,7	102,5	50,5	27	44,5	25	32,7	16	1,6	4	23	42

Indexing Plungers

threaded pin

INCH
Parts

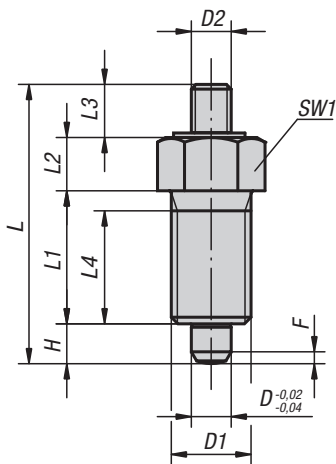

Style E
with threaded pin
without locknut

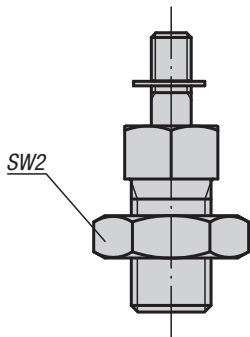

Style F
with threaded pin
with locknut

Material:

- Steel version, locking pin hardened: quality class 5.8
- Stainless steel version, locking pin hardened: threaded sleeve 1.4305 locking pin 1.4034
- Stainless steel version, locking pin not hardened: threaded sleeve 1.4305 locking pin 1.4305

Type:

- Steel version, locking pin hardened: black oxide finish, locking pin ground
- Stainless steel version, locking pin hardened: natural finish, locking pin ground
- Stainless steel version, locking pin not hardened: natural finish, locking pin ground

Part Number Example:

K0341.1903AJ

Note:

Indexing plungers are used to prevent any change in locking position due to lateral forces. A new locking position can only be set after the pin has been disengaged. Special grips can be fitted on the threaded head. This pin is also suitable for automatic actuation e.g. program controlled pneumatic cylinder or by remote control using bowden cables.

On request:

Special versions and spacer rings.

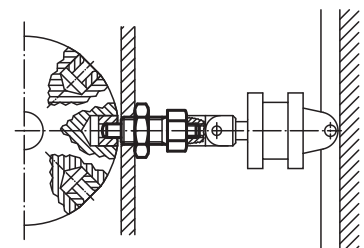

Indexing Plungers

threaded pin



KIPP Indexing Plungers, threaded pin, steel, locking pin hardened, inch

Item No. Style E	Item No. Style F	D	D1	D2	L	L1	L2	L3	L4	H	SW1	SW2	F x 30°	Spring force initial pressure F1 approx. N	Spring force final pressure F2 approx. N
K0341.1903AJ	K0341.2903AJ	3	1/4-28	M2	24	12	5	3,5	10	3,5	8	- 7/16	0,8	4,5	10
K0341.1004AK	K0341.2004AK	4	5/16-24	M3	32	15	6	7	13	4	10	- 1/2	1	6	12
K0341.1105AL	K0341.2105AL	5	3/8-24	M4	37	17	7	8	15	5	13	- 9/16	1,3	5	12
K0341.1206A5	K0341.2206A5	6	1/2-13	M6	42	20	8	8	17	6	14	- 3/4	1,8	6	14
K0341.1308A6	K0341.2308A6	8	5/8-11	M8	56	26	10	12	23	8	19	- 15/16	2,3	15	35
K0341.1410A7	K0341.2410A7	10	3/4-10	M8	62	28	12	12	25	10	22	- 1,125	2,8	15	34
K0341.1412A0	K0341.2412A0	12	3/4-16	M8	66	28	14	12	25	12	22	- 1,125	2,8	15	39
K0341.1516A8	K0341.2516A8	16	1-8	M10	80	32	18	14	28	16	27	- 1,5	3,2	20	46

KIPP Indexing Plungers, threaded pin, stainless steel, locking pin hardened, inch

Item No. Style E	Item No. Style F	D	D1	D2	L	L1	L2	L3	L4	H	SW1	SW2	F x 30°	Spring force initial pressure F1 approx. N	Spring force final pressure F2 approx. N
K0341.01903AJ	K0341.02903AJ	3	1/4-28	M2	24	12	5	3,5	10	3,5	8	- 7/16	0,8	4,5	10
K0341.01004AK	K0341.02004AK	4	5/16-24	M3	32	15	6	7	13	4	10	- 1/2	1	6	12
K0341.01105AL	K0341.02105AL	5	3/8-24	M4	37	17	7	8	15	5	13	- 9/16	1,3	5	12
K0341.01206A5	K0341.02206A5	6	1/2-13	M6	42	20	8	8	17	6	14	- 3/4	1,8	6	14
K0341.01308A6	K0341.02308A6	8	5/8-11	M8	56	26	10	12	23	8	19	- 15/16	2,3	15	35
K0341.01410A7	K0341.02410A7	10	3/4-10	M8	62	28	12	12	25	10	22	- 1,125	2,8	15	34
K0341.01412A0	K0341.02412A0	12	3/4-16	M8	66	28	14	12	25	12	22	- 1,125	2,8	15	39
K0341.01516A8	K0341.02516A8	16	1-8	M10	80	32	18	14	28	16	27	- 1,5	3,2	20	46

KIPP Indexing Plungers, threaded pin, stainless steel, locking pin not hardened, inch

Item No. Style E	Item No. Style F	D	D1	D2	L	L1	L2	L3	L4	H	SW1	SW2	F x 30°	Spring force initial pressure F1 approx. N	Spring force final pressure F2 approx. N
K0341.11903AJ	K0341.12903AJ	3	1/4-28	M2	24	12	5	3,5	10	3,5	8	- 7/16	0,8	4,5	10
K0341.11004AK	K0341.12004AK	4	5/16-24	M3	32	15	6	7	13	4	10	- 1/2	1	6	12
K0341.11105AL	K0341.12105AL	5	3/8-24	M4	37	17	7	8	15	5	13	1,3 9/16	1,3	5	12
K0341.11206A5	K0341.12206A5	6	1/2-13	M6	42	20	8	8	17	6	14	6 3/4	1,8	6	14
K0341.11308A6	K0341.12308A6	8	5/8-11	M8	56	26	10	12	23	8	19	2,3 15/16	2,3	15	35
K0341.11410A7	K0341.12410A7	10	3/4-10	M8	62	28	12	12	25	10	22	15 1,125	2,8	15	34
K0341.11412A0	K0341.12412A0	12	3/4-16	M8	66	28	14	12	25	12	22	- 1,125	2,8	15	39
K0341.11516A8	K0341.12516A8	16	1-8	M10	80	32	18	14	28	16	27	- 1,5	3,2	20	46

Indexing Plungers

threaded pin

METRIC
Parts

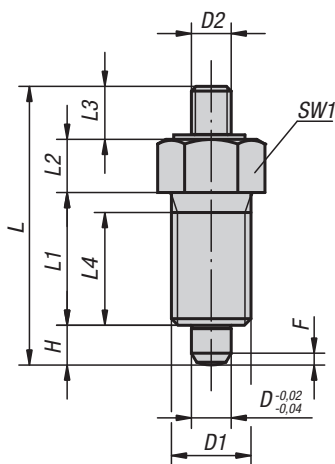

Style E
with threaded pin
without locknut

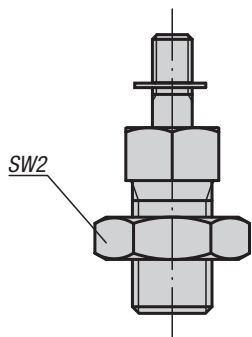

Style F
with threaded pin
with locknut

Material:

- Steel version, locking pin hardened: quality class 5.8
- Stainless steel version, locking pin hardened: threaded sleeve 1.4305 locking pin 1.4034
- Stainless steel version, locking pin not hardened: threaded sleeve 1.4305 locking pin 1.4305

Type:

- Steel version, locking pin hardened: black oxide finish, locking pin ground
- Stainless steel version, locking pin hardened: natural finish, locking pin ground
- Stainless steel version, locking pin not hardened: natural finish, locking pin ground

Part Number Example:

K0341.1903AJ

Note:

Indexing plungers are used to prevent any change in locking position due to lateral forces. A new locking position can only be set after the pin has been disengaged. Special grips can be fitted on the threaded head. This pin is also suitable for automatic actuation e.g. program controlled pneumatic cylinder or by remote control using bowden cables.

On request:

Special versions and spacer rings.

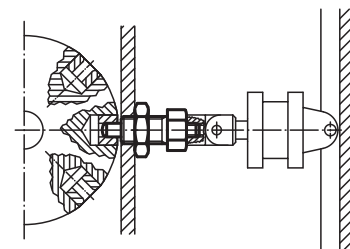

Indexing Plungers

threaded pin



KIPP Indexing Plungers, threaded pin, steel, locking pin hardened, metric

Item No. Style E	Item No. Style F	D	D1	D2	L	L1	L2	L3	L4	H	SW1	SW2	F x 30°	Spring force initial pressure F1 approx. N	Spring force final pressure F2 approx. N
K0341.1903	K0341.2903	3	M6x0,75	M2	24	12	5	3,5	10	3,5	8	- / 10	0,8	4,5	10
K0341.1004	K0341.2004	4	M8x1	M3	32	15	6	7	13	4	10	- / 13	1	6	12
K0341.1105	K0341.2105	5	M10x1	M4	37	17	7	8	15	5	13	- / 17	1,3	5	12
K0341.1206	K0341.2206	6	M12x1,5	M6	42	20	8	8	17	6	14	- / 19	1,8	6	14
K0341.1308	K0341.2308	8	M16X1,5	M8	56	26	10	12	23	8	19	- / 24	2,3	15	35
K0341.1410	K0341.2410	10	M20x1,5	M8	62	28	12	12	25	10	22	- / 30	2,8	15	34
K0341.1412	K0341.2412	12	M20x1,5	M8	66	28	14	12	25	12	22	- / 30	2,8	15	39
K0341.1516	K0341.2516	16	M24x2	M10	80	32	18	14	28	16	27	- / 36	3,2	20	46

KIPP Indexing Plungers, threaded pin, stainless steel, locking pin hardened, metric

Item No. Style E	Item No. Style F	D	D1	D2	L	L1	L2	L3	L4	H	SW1	SW2	F x 30°	Spring force initial pressure F1 approx. N	Spring force final pressure F2 approx. N
K0341.01903	K0341.02903	3	M6x0,75	M2	24	12	5	3,5	10	3,5	8	- / 10	0,8	4,5	10
K0341.01004	K0341.02004	4	M8x1	M3	32	15	6	7	13	4	10	- / 13	1	6	12
K0341.01105	K0341.02105	5	M10x1	M4	37	17	7	8	15	5	13	- / 17	1,3	5	12
K0341.01206	K0341.02206	6	M12x1,5	M6	42	20	8	8	17	6	14	- / 19	1,8	6	14
K0341.01308	K0341.02308	8	M16X1,5	M8	56	26	10	12	23	8	19	- / 24	2,3	15	35
K0341.01410	K0341.02410	10	M20x1,5	M8	62	28	12	12	25	10	22	- / 30	2,8	15	34
K0341.01412	K0341.02412	12	M20x1,5	M8	66	28	14	12	25	12	22	- / 30	2,8	15	39
K0341.01516	K0341.02516	16	M24x2	M10	80	32	18	14	28	16	27	- / 36	3,2	20	46

KIPP Indexing Plungers, threaded pin, stainless steel, locking pin not hardened, metric

Item No. Style E	Item No. Style F	D	D1	D2	L	L1	L2	L3	L4	H	SW1	SW2	F x 30°	Spring force initial pressure F1 approx. N	Spring force final pressure F2 approx. N
K0341.11903	K0341.12903	3	M6x0,75	M2	24	12	5	3,5	10	3,5	8	- / 10	0,8	4,5	10
K0341.11004	K0341.12004	4	M8x1	M3	32	15	6	7	13	4	10	- / 13	1	6	12
K0341.11105	K0341.12105	5	M10x1	M4	37	17	7	8	15	5	13	- / 17	1,3	5	12
K0341.11206	K0341.12206	6	M12x1,5	M6	42	20	8	8	17	6	14	- / 19	1,8	6	14
K0341.11308	K0341.12308	8	M16X1,5	M8	56	26	10	12	23	8	19	- / 24	2,3	15	35
K0341.11410	K0341.12410	10	M20x1,5	M8	62	28	12	12	25	10	22	- / 30	2,8	15	34
K0341.11412	K0341.12412	12	M20x1,5	M8	66	28	14	12	25	12	22	- / 30	2,8	15	39
K0341.11516	K0341.12516	16	M24x2	M10	80	32	18	14	28	16	27	- / 36	3,2	20	46

Indexing Plungers

METRIC
Parts

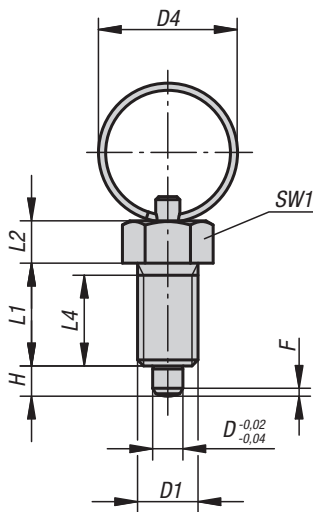
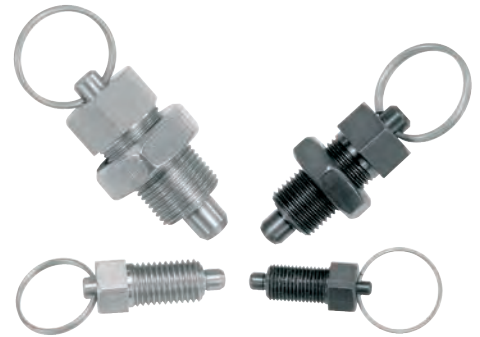

Style R
without locknut

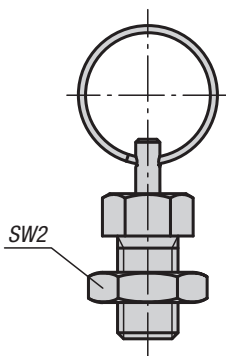

Style S
with locknut

Material:

- Steel version, locking pin hardened: quality class 5.8
- Stainless steel version, locking pin hardened: threaded sleeve 1.4305 locking pin 1.4034
- Stainless steel version, locking pin not hardened: threaded sleeve 1.4305 locking pin 1.4305

Key ring 1.4310, natural finish

Type:

- Steel version, locking pin hardened: black oxide finish, locking pin ground
- Stainless steel version, locking pin hardened: natural finish, locking pin ground
- Stainless steel version, locking pin not hardened: natural finish, locking pin ground

Part Number Example:

K0342.3004

Note:

Indexing plungers are used to prevent any change in locking position due to lateral forces. A new locking position can only be set after the pin has been disengaged. The key ring is also suitable for automatic actuation of the indexing plunger by e.g. programme-controlled pneumatic cylinder or by remote control using bowden cables.

On request:

Special versions and spacer rings.

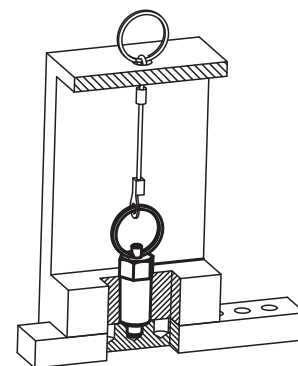

KIPP Indexing Plungers, steel, locking pin hardened, metric

Item No. Style R	Item No. Style S	D	D1	D4	L1	L2	L4	H	SW1	SW2	F x 30°	Spring force initial pressure F1 approx. N	Spring force final pressure F2 approx. N
K0342.3004	K0342.4004	4	M8x1	15	15	6	13	4	10	- / 13	1	6	12
K0342.3105	K0342.4105	5	M10x1	23	17	7	15	5	13	- / 17	1,3	5	12
K0342.3206	K0342.4206	6	M12x1,5	23	20	8	17	6	14	- / 19	1,8	6	14
K0342.3308	K0342.4308	8	M16X1,5	28	26	10	23	8	19	- / 24	2,3	15	35
K0342.3410	K0342.4410	10	M20x1,5	28	28	12	25	10	22	- / 30	2,8	15	34

KIPP Indexing Plungers, stainless steel, locking pin hardened, metric

Item No. Style R	Item No. Style S	D	D1	D4	L1	L2	L4	H	SW1	SW2	F x 30°	Spring force initial pressure F1 approx. N	Spring force final pressure F2 approx. N
K0342.03004	K0342.04004	4	M8x1	15	15	6	13	4	10	- / 13	1	6	12
K0342.03105	K0342.04105	5	M10x1	23	17	7	15	5	13	- / 17	1,3	5	12
K0342.03206	K0342.04206	6	M12x1,5	23	20	8	17	6	14	- / 19	1,8	6	14
K0342.03308	K0342.04308	8	M16X1,5	28	26	10	23	8	19	- / 24	2,3	15	35
K0342.03410	K0342.04410	10	M20x1,5	28	28	12	25	10	22	- / 30	2,8	15	34

KIPP Indexing Plungers, stainless steel, locking pin not hardened, metric

Item No. Style R	Item No. Style S	D	D1	D4	L1	L2	L4	H	SW1	SW2	F x 30°	Spring force initial pressure F1 approx. N	Spring force final pressure F2 approx. N
K0342.13004	K0342.14004	4	M8x1	15	15	6	13	4	10	- / 13	1	6	12
K0342.13105	K0342.14105	5	M10x1	23	17	7	15	5	13	- / 17	1,3	5	12
K0342.13206	K0342.14206	6	M12x1,5	23	20	8	17	6	14	- / 19	1,8	6	14
K0342.13308	K0342.14308	8	M16X1,5	28	26	10	23	8	19	- / 24	2,3	15	35
K0342.13410	K0342.14410	10	M20x1,5	28	28	12	25	10	22	- / 30	2,8	15	34

Indexing Plungers

without collar

INCH
Parts



Style G
without locknut

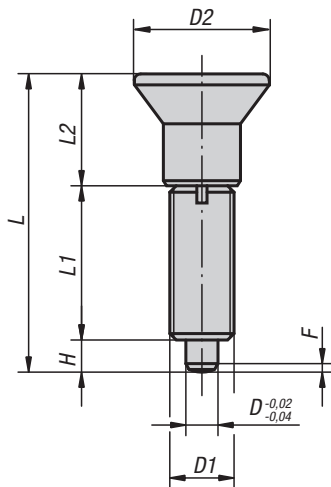

Style H
with locknut

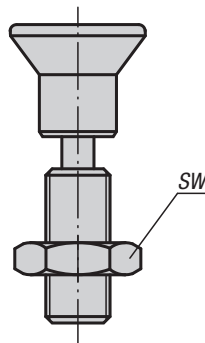

Indexing plunger
with screw-in washer

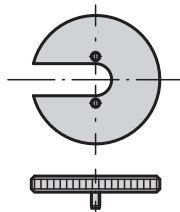
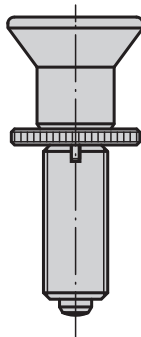

Material:

- Steel version, locking pin hardened: quality class 5.8
- Stainless steel version, locking pin hardened: threaded sleeve 1.4305 locking pin 1.4034
- Stainless steel version, locking pin not hardened: threaded sleeve 1.4305 locking pin 1.4305

Mushroom knob in black gray thermoplastic

Type:

- Steel version, locking pin hardened: black oxide finish, locking pin ground
- Stainless steel version, locking pin hardened: natural finish, locking pin ground
- Stainless steel version, locking pin not hardened: natural finish, locking pin ground

Part Number Example:

K0343.1903AJ

Note:

Indexing plungers are used to prevent any change in locking position due to lateral forces. A new locking position can only be set after the pin has been manually disengaged.

A washer is available to aid by screwing in the indexing plungers. The washer slides beneath the mushroom knob so that the carrier pins engage in the slot.

On request:

Special versions.

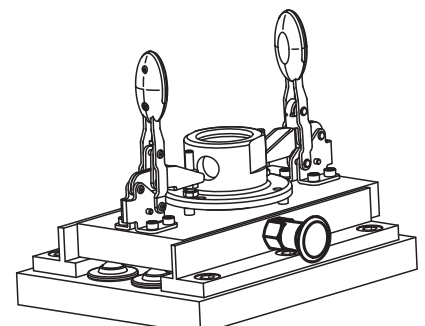

Indexing Plungers

without collar



KIPP Indexing Plungers without collar, in steel, locking pin hardened, inch

Item No. Style G	Item No. Style H	D	D1	D2	L	L1	L2	H	SW	F x 30°	Spring force initial pressure F1 approx. N	Spring force final pressure F2 approx. N	Item No. screw-in washer
K0343.1903AJ	K0343.2903AJ	3	1/4-28	14	31,5	17	11	3,5	-17/16	0,8	4,5	10	K0344.99
K0343.1004AK	K0343.2004AK	4	5/16-24	18	38,5	21	13,5	4	-11/2	1,3	6	12	K0344.90
K0343.1105AL	K0343.2105AL	5	3/8-24	21	43,5	24	14,5	5	-19/16	1,3	5	12	K0344.91
K0343.1206A5	K0343.2206A5	6	1/2-13	25	51,7	28	17,7	6	-13/4	1,8	6	14	K0344.92
K0343.1308A6	K0343.2308A6	8	5/8-11	33	68	36	24	8	-115/16	2,3	15	35	K0344.93
K0343.1410A7	K0343.2410A7	10	3/4-10	33	74	40	24	10	-11,125	2,8	15	34	K0344.94
K0343.1412A0	K0343.2412A0	12	3/4-16	33	78	42	24	12	-11,125	2,8	15	39	K0344.94
K0343.1516A8	K0343.2516A8	16	1-8	40	96	50	30	16	-11,5	3,2	20	46	K0344.95

KIPP Indexing Plungers without collar, in stainless steel, locking pin hardened, inch

Item No. Style G	Item No. Style H	D	D1	D2	L	L1	L2	H	SW	F x 30°	Spring force initial pressure F1 approx. N	Spring force final pressure F2 approx. N	Item No. screw-in washer
K0343.01903AJ	K0343.02903AJ	3	1/4-28	14	31,5	17	11	3,5	-17/16	0,8	4,5	10	K0344.99
K0343.01004AK	K0343.02004AK	4	5/16-24	18	38,5	21	13,5	4	-11/2	1,3	6	12	K0344.90
K0343.01105AL	K0343.02105AL	5	3/8-24	21	43,5	24	14,5	5	-19/16	1,3	5	12	K0344.91
K0343.01206A5	K0343.02206A5	6	1/2-13	25	51,7	28	17,7	6	-13/4	1,8	6	14	K0344.92
K0343.01308A6	K0343.02308A6	8	5/8-11	33	68	36	24	8	-115/16	2,3	15	35	K0344.93
K0343.01410A7	K0343.02410A7	10	3/4-10	33	74	40	24	10	-11,125	2,8	15	34	K0344.94
K0343.01412A0	K0343.02412A0	12	3/4-16	33	78	42	24	12	-11,125	2,8	15	39	K0344.94
K0343.01516A8	K0343.02516A8	16	1-8	40	96	50	30	16	-11,5	3,2	20	46	K0344.95

KIPP Indexing Plungers without collar, in stainless steel, locking pin not hardened, inch

Item No. Style G	Item No. Style H	D	D1	D2	L	L1	L2	H	SW	F x 30°	Spring force initial pressure F1 approx. N	Spring force final pressure F2 approx. N	Item No. screw-in washer
K0343.11903AJ	K0343.12903AJ	3	1/4-28	14	31,5	17	11	3,5	-17/16	0,8	4,5	10	K0344.99
K0343.11004AK	K0343.12004AK	4	5/16-24	18	38,5	21	13,5	4	-11/2	1,3	6	12	K0344.90
K0343.11105AL	K0343.12105AL	5	3/8-24	21	43,5	24	14,5	5	-19/16	1,3	5	12	K0344.91
K0343.11206A5	K0343.12206A5	6	1/2-13	25	51,7	28	17,7	6	-13/4	1,8	6	14	K0344.92
K0343.11308A6	K0343.12308A6	8	5/8-11	33	68	36	24	8	-115/16	2,3	15	35	K0344.93
K0343.11410A7	K0343.12410A7	10	3/4-10	33	74	40	24	10	-11,125	2,8	15	34	K0344.94
K0343.11412A0	K0343.12412A0	12	3/4-16	33	78	42	24	12	-11,125	2,8	15	39	K0344.94
K0343.11516A8	K0343.12516A8	16	1-8	40	96	50	30	16	-11,5	3,2	20	46	K0344.95

Indexing Plungers

without collar

METRIC
Parts



Style G
without locknut

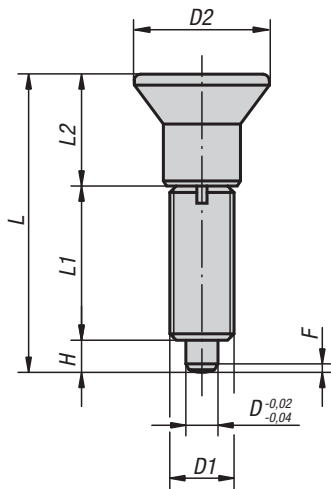

Style H
with locknut

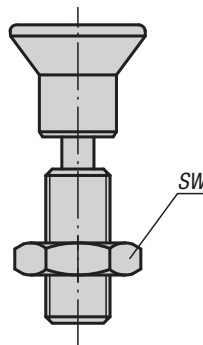

Indexing plunger
with screw-in washer

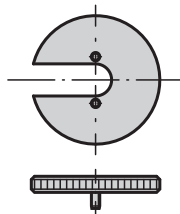
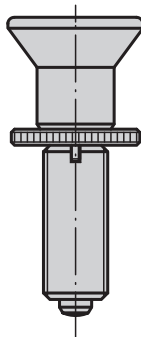

Material:

- Steel version, locking pin hardened: quality class 5.8
- Stainless steel version, locking pin hardened: threaded sleeve 1.4305 locking pin 1.4034
- Stainless steel version, locking pin not hardened: threaded sleeve 1.4305 locking pin 1.4305

Mushroom knob in black gray thermoplastic

Type:

- Steel version, locking pin hardened: black oxide finish, locking pin ground
- Stainless steel version, locking pin hardened: natural finish, locking pin ground
- Stainless steel version, locking pin not hardened: natural finish, locking pin ground

Part Number Example:

K0343.1903AJ

Note:

Indexing plungers are used to prevent any change in locking position due to lateral forces. A new locking position can only be set after the pin has been manually disengaged.

A washer is available to aid by screwing in the indexing plungers. The washer slides beneath the mushroom knob so that the carrier pins engage in the slot.

On request:

Special versions.

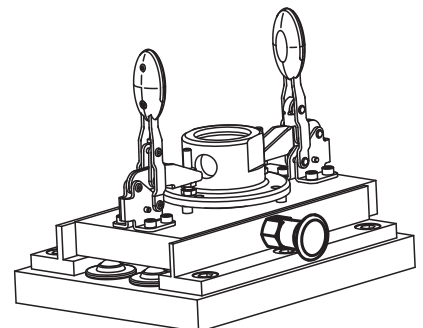

Indexing Plungers

without collar



KIPP Indexing Plungers without collar, in steel, locking pin hardened, metric

Item No. Style G	Item No. Style H	D	D1	D2	L	L1	L2	H	SW	F x 30°	Spring force initial pressure F1 approx. N	Spring force final pressure F2 approx. N	Item No. screw-in washer
K0343.1903	K0343.2903	3	M6x0,75	14	31,5	17	11	3,5	- / 10	0,8	4,5	10	K0344.99
K0343.1004	K0343.2004	4	M8x1	18	38,5	21	13,5	4	- / 13	1,3	6	12	K0344.90
K0343.1105	K0343.2105	5	M10x1	21	43,5	24	14,5	5	- / 17	1,3	5	12	K0344.91
K0343.1206	K0343.2206	6	M12x1,5	25	51,7	28	17,7	6	- / 19	1,8	6	14	K0344.92
K0343.1308	K0343.2308	8	M16x1,5	33	68	36	24	8	- / 24	2,3	15	35	K0344.93
K0343.1410	K0343.2410	10	M20x1,5	33	74	40	24	10	- / 30	2,8	15	34	K0344.94
K0343.1412	K0343.2412	12	M20x1,5	33	78	42	24	12	- / 30	2,8	15	39	K0344.94
K0343.1516	K0343.2516	16	M24x2	40	96	50	30	16	- / 36	3,2	20	46	K0344.95

KIPP Indexing Plungers without collar, in stainless steel, locking pin hardened, metric

Item No. Style G	Item No. Style H	D	D1	D2	L	L1	L2	H	SW	F x 30°	Spring force initial pressure F1 approx. N	Spring force final pressure F2 approx. N	Item No. screw-in washer
K0343.01903	K0343.02903	3	M6x0,75	14	31,5	17	11	3,5	- / 10	0,8	4,5	10	K0344.99
K0343.01004	K0343.02004	4	M8x1	18	38,5	21	13,5	4	- / 13	1,3	6	12	K0344.90
K0343.01105	K0343.02105	5	M10x1	21	43,5	24	14,5	5	- / 17	1,3	5	12	K0344.91
K0343.01206	K0343.02206	6	M12x1,5	25	51,7	28	17,7	6	- / 19	1,8	6	14	K0344.92
K0343.01308	K0343.02308	8	M16x1,5	33	68	36	24	8	- / 24	2,3	15	35	K0344.93
K0343.01410	K0343.02410	10	M20x1,5	33	74	40	24	10	- / 30	2,8	15	34	K0344.94
K0343.01412	K0343.02412	12	M20x1,5	33	78	42	24	12	- / 30	2,8	15	39	K0344.94
K0343.01516	K0343.02516	16	M24x2	40	96	50	30	16	- / 36	3,2	20	46	K0344.95

KIPP Indexing Plungers without collar, in stainless steel, locking pin not hardened, metric

Item No. Style G	Item No. Style H	D	D1	D2	L	L1	L2	H	SW	F x 30°	Spring force initial pressure F1 approx. N	Spring force final pressure F2 approx. N	Item No. screw-in washer
K0343.11903	K0343.12903	3	M6x0,75	14	31,5	17	11	3,5	- / 10	0,8	4,5	10	K0344.99
K0343.11004	K0343.12004	4	M8x1	18	38,5	21	13,5	4	- / 13	1,3	6	12	K0344.90
K0343.11105	K0343.12105	5	M10x1	21	43,5	24	14,5	5	- / 17	1,3	5	12	K0344.91
K0343.11206	K0343.12206	6	M12x1,5	25	51,7	28	17,7	6	- / 19	1,8	6	14	K0344.92
K0343.11308	K0343.12308	8	M16x1,5	33	68	36	24	8	- / 24	2,3	15	35	K0344.93
K0343.11410	K0343.12410	10	M20x1,5	33	74	40	24	10	- / 30	2,8	15	34	K0344.94
K0343.11412	K0343.12412	12	M20x1,5	33	78	42	24	12	- / 30	2,8	15	39	K0344.94
K0343.11516	K0343.12516	16	M24x2	40	96	50	30	16	- / 36	3,2	20	46	K0344.95

Indexing Plungers

without collar with extended locking pin

INCH
Parts



Style G
without locknut

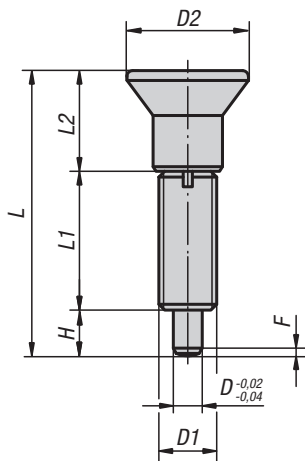

Style H
with locknut

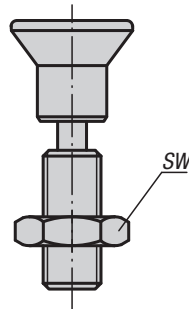

Indexing plunger
with screw-in washer

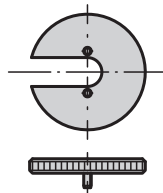
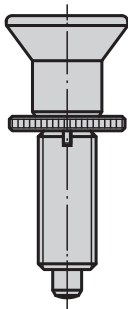

Material:

- Steel version, locking pin hardened: quality class 5.8
- Stainless steel version, locking pin hardened: threaded sleeve 1.4305 locking pin 1.4034
- Stainless steel version, locking pin not hardened: threaded sleeve 1.4305 locking pin 1.4305

Mushroom knob in black gray thermoplastic

Type:

- Steel version, locking pin hardened: black oxide finish, locking pin ground
- Stainless steel version, locking pin hardened: natural finish, locking pin ground
- Stainless steel version, locking pin not hardened: natural finish, locking pin ground

Part Number Example:

K0633.21903AJ

Note:

Indexing plungers are used to prevent any change in locking position due to lateral forces. A new locking position can only be set after the pin has been manually disengaged.

A washer is available to aid by screwing in the indexing plungers. The washer slides beneath the mushroom knob so that the carrier pins engage in the slot.

On request:

Special versions.

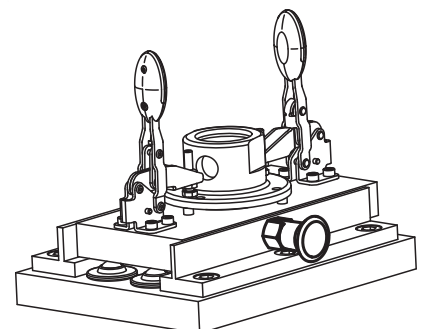

Indexing Plungers

without collar with extended locking pin

KIPP Indexing Plungers without collar and extended locking pin, in steel, locking pin hardened, inch

Item No. Style G	Item No. Style H	D	D1	D2	L	L1	L2	H	SW	F x 30°	Spring force initial pressure F1 approx. N	Spring force final pressure F2 approx. N	Item No. screw-in washer
K0633.21903AJ	K0633.22903AJ	3	1/4-28	14	33	17	11	5	- 7/16	0,8	4,5	12	K0344.99
K0633.21004AK	K0633.22004AK	4	5/16-24	18	40,5	21	13,5	6	- 1/2	1	6	15	K0344.90
K0633.21105AL	K0633.22105AL	5	3/8-24	21	46,5	24	14,5	8	- 9/16	1,3	5	16	K0344.91
K0633.21206A5	K0633.22206A5	6	1/2-13	25	54,7	28	17,7	9	- 3/4	1,8	6	18	K0344.92
K0633.21308A6	K0633.22308A6	8	5/8-11	33	72	36	24	12	- 15/16	2,3	15	45	K0344.93
K0633.21410A7	K0633.22410A7	10	3/4-10	33	79	40	24	15	- 1,125	2,8	15	43	K0344.94
K0633.21412A0	K0633.22412A0	12	3/4-16	33	84	42	24	18	- 1,125	2,8	15	51	K0344.94
K0633.21516A8	K0633.22516A8	16	1-8	40	104	50	30	24	- 1,5	3,2	20	60	K0344.95

KIPP Indexing Plungers without collar and extended locking pin, in stainless steel, locking pin hardened, inch

Item No. Style G	Item No. Style H	D	D1	D2	L	L1	L2	H	SW	F x 30°	Spring force initial pressure F1 approx. N	Spring force final pressure F2 approx. N	Item No. screw-in washer
K0633.201903AJ	K0633.202903AJ	3	1/4-28	14	33	17	11	5	- 7/16	0,8	4,5	12	K0344.99
K0633.201004AK	K0633.202004AK	4	5/16-24	18	40,5	21	13,5	6	- 1/2	1	6	15	K0344.90
K0633.201105AL	K0633.202105AL	5	3/8-24	21	46,5	24	14,5	8	- 9/16	1,3	5	16	K0344.91
K0633.201206A5	K0633.202206A5	6	1/2-13	25	54,7	28	17,7	9	- 3/4	1,8	6	18	K0344.92
K0633.201308A6	K0633.202308A6	8	5/8-11	33	72	36	24	12	- 15/16	2,3	15	45	K0344.93
K0633.201410A7	K0633.202410A7	10	3/4-10	33	79	40	24	15	- 1,125	2,8	15	43	K0344.94
K0633.201412A0	K0633.202412A0	12	3/4-16	33	84	42	24	18	- 1,125	2,8	15	51	K0344.94
K0633.201516A8	K0633.202516A8	16	1-8	40	104	50	30	24	- 1,5	3,2	20	60	K0344.95

KIPP Indexing Plungers without collar and extended locking pin, in stainless steel, locking pin not hardened, inch

Item No. Style G	Item No. Style H	D	D1	D2	L	L1	L2	H	SW	F x 30°	Spring force initial pressure F1 approx. N	Spring force final pressure F2 approx. N	Item No. screw-in washer
K0633.211903AJ	K0633.212903AJ	3	1/4-28	14	33	17	11	5	- 7/16	0,8	4,5	12	K0344.99
K0633.211004AK	K0633.212004AK	4	5/16-24	18	40,5	21	13,5	6	- 1/2	1	6	15	K0344.90
K0633.211105AL	K0633.212105AL	5	3/8-24	21	46,5	24	14,5	8	- 9/16	1,3	5	16	K0344.91
K0633.211206A5	K0633.212206A5	6	1/2-13	25	54,7	28	17,7	9	- 3/4	1,8	6	18	K0344.92
K0633.211308A6	K0633.212308A6	8	5/8-11	33	72	36	24	12	- 15/16	2,3	15	45	K0344.93
K0633.211410A7	K0633.212410A7	10	3/4-10	33	79	40	24	15	- 1,125	2,8	15	43	K0344.94
K0633.211412A0	K0633.212412A0	12	3/4-16	33	84	42	24	18	- 1,125	2,8	15	51	K0344.94
K0633.211516A8	K0633.212516A8	16	1-8	40	104	50	30	24	- 1,5	3,2	20	60	K0344.95

Indexing Plungers

without collar with extended locking pin

METRIC
Parts



Style G
without locknut

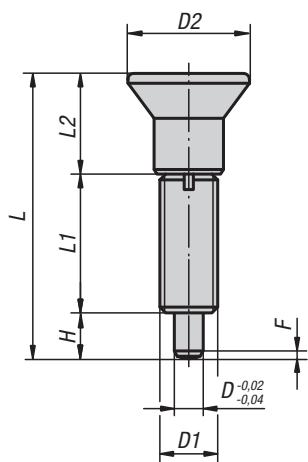

Indexing plunger
with screw-in washer

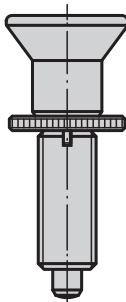

Style H
with locknut

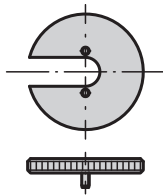
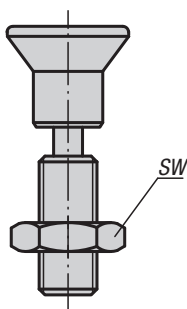

Material:

- Steel version, locking pin hardened: quality class 5.8
- Stainless steel version, locking pin hardened: threaded sleeve 1.4305 locking pin 1.4034
- Stainless steel version, locking pin not hardened: threaded sleeve 1.4305 locking pin 1.4305

Mushroom knob in black gray thermoplastic

Type:

- Steel version, locking pin hardened: black oxide finish, locking pin ground
- Stainless steel version, locking pin hardened: natural finish, locking pin ground
- Stainless steel version, locking pin not hardened: natural finish, locking pin ground

Part Number Example:

K0633.21903AJ

Note:

Indexing plungers are used to prevent any change in locking position due to lateral forces. A new locking position can only be set after the pin has been manually disengaged.

A washer is available to aid by screwing in the indexing plungers. The washer slides beneath the mushroom knob so that the carrier pins engage in the slot.

On request:

Special versions.

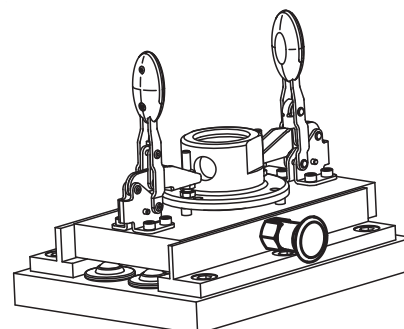

Indexing Plungers

without collar with extended locking pin

KIPP Indexing Plungers without collar and extended locking pin, in steel, locking pin hardened, metric

Item No. Style G	Item No. Style H	D	D1	D2	L	L1	L2	H	SW	F x 30°	Spring force initial pressure F1 approx. N	Spring force final pressure F2 approx. N	Item No. screw-in washer
K0633.21903	K0633.22903	3	M6x0,75	14	33	17	11	5	- / 10	0,8	4,5	12	K0344.99
K0633.21004	K0633.22004	4	M8x1	18	40,5	21	13,5	6	- / 13	1	6	15	K0344.90
K0633.21105	K0633.22105	5	M10x1	21	46,5	24	14,5	8	- / 17	1,3	5	16	K0344.91
K0633.21206	K0633.22206	6	M12x1,5	25	54,7	28	17,7	9	- / 19	1,8	6	18	K0344.92
K0633.21308	K0633.22308	8	M16x1,5	33	72	36	24	12	- / 24	2,3	15	45	K0344.93
K0633.21410	K0633.22410	10	M20x1,5	33	79	40	24	15	- / 30	2,8	15	43	K0344.94
K0633.21412	K0633.22412	12	M20x1,5	33	84	42	24	18	- / 30	2,8	15	51	K0344.94
K0633.21516	K0633.22516	16	M24x2	40	104	50	30	24	- / 36	3,2	20	60	K0344.95

KIPP Indexing Plungers without collar and extended locking pin, in stainless steel, locking pin hardened, metric

Item No. Style G	Item No. Style H	D	D1	D2	L	L1	L2	H	SW	F x 30°	Spring force initial pressure F1 approx. N	Spring force final pressure F2 approx. N	Item No. screw-in washer
K0633.201903	K0633.202903	3	M6x0,75	14	33	17	11	5	- / 10	0,8	4,5	12	K0344.99
K0633.201004	K0633.202004	4	M8x1	18	40,5	21	13,5	6	- / 13	1	6	15	K0344.90
K0633.201105	K0633.202105	5	M10x1	21	46,5	24	14,5	8	- / 17	1,3	5	16	K0344.91
K0633.201206	K0633.202206	6	M12x1,5	25	54,7	28	17,7	9	- / 19	1,8	6	18	K0344.92
K0633.201308	K0633.202308	8	M16x1,5	33	72	36	24	12	- / 24	2,3	15	45	K0344.93
K0633.201410	K0633.202410	10	M20x1,5	33	79	40	24	15	- / 30	2,8	15	43	K0344.94
K0633.201412	K0633.202412	12	M20x1,5	33	84	42	24	18	- / 30	2,8	15	51	K0344.94
K0633.201516	K0633.202516	16	M24x2	40	104	50	30	24	- / 36	3,2	20	60	K0344.95

KIPP Indexing Plungers without collar and extended locking pin, in stainless steel, locking pin not hardened, metric

Item No. Style G	Item No. Style H	D	D1	D2	L	L1	L2	H	SW	F x 30°	Spring force initial pressure F1 approx. N	Spring force final pressure F2 approx. N	Item No. screw-in washer
K0633.211903	K0633.212903	3	M6x0,75	14	33	17	11	5	- / 10	0,8	4,5	12	K0344.99
K0633.211004	K0633.212004	4	M8x1	18	40,5	21	13,5	6	- / 13	1	6	15	K0344.90
K0633.211105	K0633.212105	5	M10x1	21	46,5	24	14,5	8	- / 17	1,3	5	16	K0344.91
K0633.211206	K0633.212206	6	M12x1,5	25	54,7	28	17,7	9	- / 19	1,8	6	18	K0344.92
K0633.211308	K0633.212308	8	M16x1,5	33	72	36	24	12	- / 24	2,3	15	45	K0344.93
K0633.211410	K0633.212410	10	M20x1,5	33	79	40	24	15	- / 30	2,8	15	43	K0344.94
K0633.211412	K0633.212412	12	M20x1,5	33	84	42	24	18	- / 30	2,8	15	51	K0344.94
K0633.211516	K0633.212516	16	M24x2	40	104	50	30	24	- / 36	3,2	20	60	K0344.95

Indexing Plungers

without collar, stainless steel



Style G
without locknut

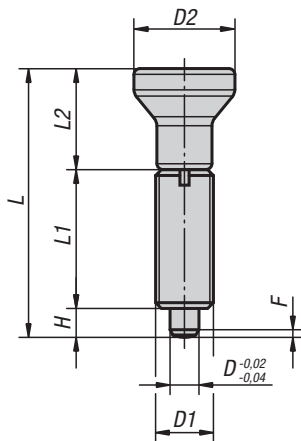

Style H
with locknut

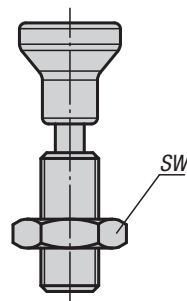

Indexing plunger
with screw-in washer

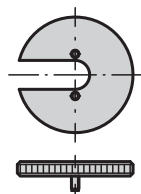
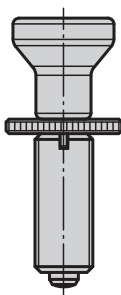

Material:

- Locking pin hardened:
threaded sleeve 1.4305
locking pin 1.4034
- Locking pin not hardened:
threaded sleeve 1.4305
locking pin 1.4305

Mushroom knob 1.4305, electrolytic-polish

Type:

Natural finish; locking pin ground

Part Number Example:

K0634.001903AJ

Note:

Indexing plungers are used to prevent any change in locking position due to lateral forces. A new locking position can only be set after the bolt has been manually disengaged. In order to screw in the Indexing Plungers, a screw-in washer can be supplied. The washer is slid beneath the disengaged mushroom knob so that the follower pins engage in the slot.

On request:

Special versions.

KIPP Indexing Plungers, without collar, in stainless steel, locking pin hardened, inch

Item No. Style G	Item No. Style H	D	D1	D2	L	L1	L2	H	SW	F x 30°	Spring force initial pressure F1 approx. N	Spring force final pressure F2 approx. N	Item No. screw-in washer
K0634.001903AJ	K0634.002903AJ	3	1/4-28	14	34,5	17	14	3,5	- 17/16	0,8	4,5	10	K0344.99
K0634.001004AK	K0634.002004AK	4	5/16-24	18	43	21	18	4	- 1 1/2	1	6	12	K0344.90
K0634.001105AL	K0634.002105AL	5	3/8-24	21	50	24	21	5	- 19/16	1,3	5	12	K0344.91
K0634.001206A5	K0634.002206A5	6	1/2-13	25	59	28	25	6	- 1 3/4	1,8	6	14	K0344.92
K0634.001308A6	K0634.002308A6	8	5/8-11	33	77	36	33	8	- 1 15/16	2,3	15	35	K0344.93
K0634.001410A7	K0634.002410A7	10	3/4-10	33	83	40	33	10	- 1 1,125	2,6	15	34	K0344.94
K0634.001412A0	K0634.002412A0	12	3/4-16	33	87	42	33	12	- 1 1,125	2,8	15	39	K0344.94
K0634.001516A8	K0634.002516A8	16	1-8	40	106	50	40	16	- 1 1,5	3,2	20	46	K0344.95

Indexing Plungers

without collar, stainless steel



KIPP Indexing Plungers, without collar, in stainless steel, locking pin not hardened, inch

Item No. Style G	Item No. Style H	D	D1	D2	L	L1	L2	H	SW	F x 30°	Spring force initial pressure F1 approx. N	Spring force final pressure F2 approx. N	Item No. screw-in washer
K0634.111903AJ	K0634.112903AJ	3	1/4-28	14	34,5	17	14	3,5	- 7/16	0,8	4,5	10	K0344.99
K0634.111004AK	K0634.112004AK	4	5/16-24	18	43	21	18	4	- 1/2	1	6	12	K0344.90
K0634.111105AL	K0634.112105AL	5	3/8-24	21	50	24	21	5	- 9/16	1,3	5	12	K0344.91
K0634.111206A5	K0634.112206A5	6	1/2-13	25	59	28	25	6	- 3/4	1,8	6	14	K0344.92
K0634.111308A6	K0634.112308A6	8	5/8-11	33	77	36	33	8	- 15/16	2,3	15	35	K0344.93
K0634.111410A7	K0634.112410A7	10	3/4-10	33	83	40	33	10	- 1,125	2,6	15	34	K0344.94
K0634.111412A0	K0634.112412A0	12	3/4-16	33	87	42	33	12	- 1,125	2,8	15	39	K0344.94
K0634.111516A8	K0634.112516A8	16	1-8	40	106	50	40	16	- 1,5	3,2	20	46	K0344.95

KIPP Indexing Plungers, without collar, in stainless steel, locking pin hardened, metric

Item No. Style G	Item No. Style H	D	D1	D2	L	L1	L2	H	SW	F x 30°	Spring force initial pressure F1 approx. N	Spring force final pressure F2 approx. N	Item No. screw-in washer
K0634.001903	K0634.002903	3	M6x0,75	14	34,5	17	14	3,5	- / 10	0,8	4,5	10	K0344.99
K0634.001004	K0634.002004	4	M8x1	18	43	21	18	4	- / 13	1	6	12	K0344.90
K0634.001105	K0634.002105	5	M10x1	21	50	24	21	5	- / 17	1,3	5	12	K0344.91
K0634.001206	K0634.002206	6	M12x1,5	25	59	28	25	6	- / 19	1,8	6	14	K0344.92
K0634.001308	K0634.002308	8	M16x1,5	33	77	36	33	8	- / 24	2,3	15	35	K0344.93
K0634.001410	K0634.002410	10	M20x1,5	33	83	40	33	10	- / 30	2,8	15	34	K0344.94
K0634.001412	K0634.002412	12	M20x1,5	33	87	42	33	12	- / 30	2,8	15	39	K0344.94
K0634.001516	K0634.002516	16	M24x2	40	106	50	40	16	- / 36	3,2	20	46	K0344.95

KIPP Indexing Plungers, without collar, in stainless steel, locking pin not hardened, metric

Item No. Style G	Item No. Style H	D	D1	D2	L	L1	L2	H	SW	F x 30°	Spring force initial pressure F1 approx. N	Spring force final pressure F2 approx. N	Item No. screw-in washer
K0634.111903	K0634.112903	3	M6x0,75	14	34,5	17	14	3,5	- / 10	0,8	4,5	10	K0344.99
K0634.111004	K0634.112004	4	M8x1	18	43	21	18	4	- / 13	1	6	12	K0344.90
K0634.111105	K0634.112105	5	M10x1	21	50	24	21	5	- / 17	1,3	5	12	K0344.91
K0634.111206	K0634.112206	6	M12x1,5	25	59	28	25	6	- / 19	1,8	6	14	K0344.92
K0634.111308	K0634.112308	8	M16x1,5	33	77	36	33	8	- / 24	2,3	15	35	K0344.93
K0634.111410	K0634.112410	10	M20x1,5	33	83	40	33	10	- / 30	2,8	15	34	K0344.94
K0634.111412	K0634.112412	12	M20x1,5	33	87	42	33	12	- / 30	2,8	15	39	K0344.94
K0634.111516	K0634.112516	16	M24x2	40	106	50	40	16	- / 36	3,2	20	46	K0344.95

Indexing Plungers

without collar

INCH
Parts

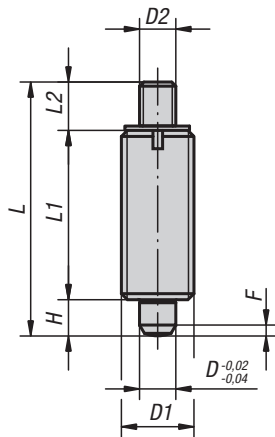

Style J
with threaded pin
without locknut

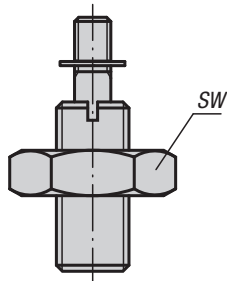

Style K
with threaded pin
with locknut

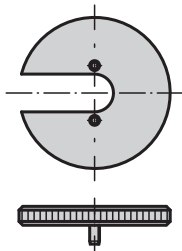

Material:

- Steel version, locking pin hardened:
quality class 5.8
- Stainless steel version, locking pin hardened:
threaded sleeve 1.4305
locking pin 1.4034
- Stainless steel version, locking pin not hardened:
threaded sleeve 1.4305
locking pin 1.4305

Type:

- Steel version, locking pin hardened:
black oxide finish, locking pin ground
- Stainless steel version, locking pin hardened:
natural finish, locking pin ground
- Stainless steel version, locking pin not hardened:
natural finish, locking pin ground

Part Number Example:

K0345.1903AJ

Note:

Indexing Plungers are used to prevent any change in locking position due to lateral forces. A new locking position can only be set after the bolt has been disengaged.

Special grips can be fitted on the projecting threaded pin. This pin is also suitable for automatic actuation by e.g. program controlled pneumatic cylinder or by remote control using bowden cables.

A washer is available to aid screwing in the indexing plungers. The washer is placed on the threaded sleeve so that the carrier pins engage in the slot.

On request:

Special versions.

Indexing Plungers

without collar



KIPP Indexing Plungers, without collar, threaded pin, steel, locking pin hardened, inch

Item No. Style J	Item No. Style K	D	D1	D2	L	L1	L2	H	SW	F x 30°	Spring force initial pressure F1 approx. N	Spring force final pressure F2 approx. N	Item No. screw-in washer
K0345.1903AJ	K0345.2903AJ	3	1/4-28	M2	24	17	3,5	3,5	- 17/16	0,8	4,5	10	K0344.99
K0345.1004AK	K0345.2004AK	4	5/16-24	M3	32	21	7	4	- 1 1/2	1	6	12	K0344.90
K0345.1105AL	K0345.2105AL	5	3/8-24	M4	37	24	8	5	- 19/16	1,3	5	12	K0344.91
K0345.1206A5	K0345.2206A5	6	1/2-13	M6	42	28	8	6	- 1 3/4	1,8	6	14	K0344.92
K0345.1308A6	K0345.2308A6	8	5/8-11	M8	56	36	12	8	- 1 15/16	2,3	15	35	K0344.93
K0345.1410A7	K0345.2410A7	10	3/4-10	M8	62	40	12	10	- 1 1,125	2,8	15	34	K0344.94
K0345.1412A0	K0345.2412A0	12	3/4-16	M8	66	42	12	12	- 1 1,125	2,8	15	39	K0344.94
K0345.1516A8	K0345.2516A8	16	1-8	M10	80	50	14	16	- 1 1,5	3,2	20	46	K0344.95

KIPP Indexing Plungers, without collar, threaded pin, stainless steel, locking pin hardened, inch

Item No. Style J	Item No. Style K	D	D1	D2	L	L1	L2	H	SW	F x 30°	Spring force initial pressure F1 approx. N	Spring force final pressure F2 approx. N	Item No. screw-in washer
K0345.01903AJ	K0345.02903AJ	3	1/4-28	M2	24	17	3,5	3,5	- 17/16	0,8	4,5	10	K0344.99
K0345.01004AK	K0345.02004AK	4	5/16-24	M3	32	21	7	4	- 1 1/2	1	6	12	K0344.90
K0345.01105AL	K0345.02105AL	5	3/8-24	M4	37	24	8	5	- 19/16	1,3	5	12	K0344.91
K0345.01206A5	K0345.02206A5	6	1/2-13	M6	42	28	8	6	- 1 3/4	1,8	6	14	K0344.92
K0345.01308A6	K0345.02308A6	8	5/8-11	M8	56	36	12	8	- 1 15/16	2,3	15	35	K0344.93
K0345.01410A7	K0345.02410A7	10	3/4-10	M8	62	40	12	10	- 1 1,125	2,8	15	34	K0344.94
K0345.01412A0	K0345.02412A0	12	3/4-16	M8	66	42	12	12	- 1 1,125	2,8	15	39	K0344.94
K0345.01516A8	K0345.02516A8	16	1-8	M10	80	50	14	16	- 1 1,5	3,2	20	46	K0344.95

KIPP Indexing Plungers, without collar, threaded pin, stainless steel, locking pin not hardened, inch

Item No. Style J	Item No. Style K	D	D1	D2	L	L1	L2	H	SW	F x 30°	Spring force initial pressure F1 approx. N	Spring force final pressure F2 approx. N	Item No. screw-in washer
K0345.11903AJ	K0345.12903AJ	3	1/4-28	M2	24	17	3,5	3,5	- 17/16	0,8	4,5	10	K0344.99
K0345.11004AK	K0345.12004AK	4	5/16-24	M3	32	21	7	4	- 1 1/2	1	6	12	K0344.90
K0345.11105AL	K0345.12105AL	5	3/8-24	M4	37	24	8	5	- 19/16	1,3	5	12	K0344.91
K0345.11206A5	K0345.12206A5	6	1/2-13	M6	42	28	8	6	- 1 3/4	1,8	6	14	K0344.92
K0345.11308A6	K0345.12308A6	8	5/8-11	M8	56	36	12	8	- 1 15/16	2,3	15	35	K0344.93
K0345.11410A7	K0345.12410A7	10	3/4-10	M8	62	40	12	10	- 1 1,125	2,8	15	34	K0344.94
K0345.11412A0	K0345.12412A0	12	3/4-16	M8	66	42	12	12	- 1 1,125	2,8	15	39	K0344.94
K0345.11516A8	K0345.12516A8	16	1-8	M10	80	50	14	16	- 1 1,5	3,2	20	46	K0344.95

Indexing Plungers

without collar

METRIC
Parts

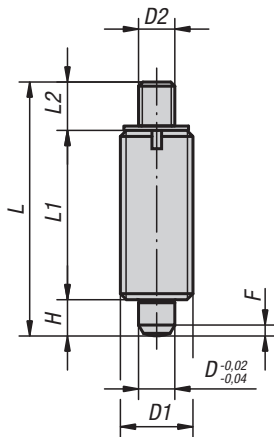

Style J
with threaded pin
without locknut

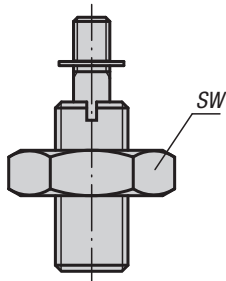

Style K
with threaded pin
with locknut

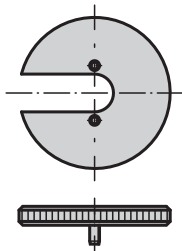

Material:

- Steel version, locking pin hardened: quality class 5.8
- Stainless steel version, locking pin hardened: threaded sleeve 1.4305 locking pin 1.4034
- Stainless steel version, locking pin not hardened: threaded sleeve 1.4305 locking pin 1.4305

Type:

- Steel version, locking pin hardened: black oxide finish, locking pin ground
- Stainless steel version, locking pin hardened: natural finish, locking pin ground
- Stainless steel version, locking pin not hardened: natural finish, locking pin ground

Part Number Example:

K0345.1903AJ

Note:

Indexing Plungers are used to prevent any change in locking position due to lateral forces. A new locking position can only be set after the bolt has been disengaged.

Special grips can be fitted on the projecting threaded pin. This pin is also suitable for automatic actuation by e.g. program controlled pneumatic cylinder or by remote control using bowden cables.

A washer is available to aid screwing in the indexing plungers. The washer is placed on the threaded sleeve so that the carrier pins engage in the slot.

On request:

Special versions.

Indexing Plungers

without collar



KIPP Indexing Plungers, without collar, threaded pin, steel, locking pin hardened, metric

Item No. Style J	Item No. Style K	D	D1	D2	L	L1	L2	H	SW	F x 30°	Spring force initial pressure F1 approx. N	Spring force final pressure F2 approx. N	Item No. screw-in washer
K0345.1903	K0345.2903	3	M6x0,75	M2	24	17	3,5	3,5	-/10	0,8	4,5	10	K0344.99
K0345.1004	K0345.2004	4	M8x1	M3	32	21	7	4	-/13	1	6	12	K0344.90
K0345.1105	K0345.2105	5	M10x1	M4	37	24	8	5	-/17	1,3	5	12	K0344.91
K0345.1206	K0345.2206	6	M12x1,5	M6	42	28	8	6	-/19	1,8	6	14	K0344.92
K0345.1308	K0345.2308	8	M16x1,5	M8	56	36	12	8	-/24	2,3	15	35	K0344.93
K0345.1410	K0345.2410	10	M20x1,5	M8	62	40	12	10	-/30	2,8	15	34	K0344.94
K0345.1412	K0345.2412	12	M20x1,5	M8	66	42	12	12	-/30	2,8	15	39	K0344.94
K0345.1516	K0345.2516	16	M24x2	M10	80	50	14	16	-/36	3,2	20	46	K0344.95

KIPP Indexing Plungers, without collar, threaded pin, stainless steel, locking pin hardened, metric

Item No. Style J	Item No. Style K	D	D1	D2	L	L1	L2	H	SW	F x 30°	Spring force initial pressure F1 approx. N	Spring force final pressure F2 approx. N	Item No. screw-in washer
K0345.01903	K0345.02903	3	M6x0,75	M2	24	17	3,5	3,5	-/10	0,8	4,5	10	K0344.99
K0345.01004	K0345.02004	4	M8x1	M3	32	21	7	4	-/13	1	6	12	K0344.90
K0345.01105	K0345.02105	5	M10x1	M4	37	24	8	5	-/17	1,3	5	12	K0344.91
K0345.01206	K0345.02206	6	M12x1,5	M6	42	28	8	6	-/19	1,8	6	14	K0344.92
K0345.01308	K0345.02308	8	M16x1,5	M8	56	36	12	8	-/24	2,3	15	35	K0344.93
K0345.01410	K0345.02410	10	M20x1,5	M8	62	40	12	10	-/30	2,8	15	34	K0344.94
K0345.01412	K0345.02412	12	M20x1,5	M8	66	42	12	12	-/30	2,8	15	39	K0344.94
K0345.01516	K0345.02516	16	M24x2	M10	80	50	14	16	-/36	3,2	20	46	K0344.95

KIPP Indexing Plungers, without collar, threaded pin, stainless steel, locking pin not hardened, metric

Item No. Style J	Item No. Style K	D	D1	D2	L	L1	L2	H	SW	F x 30°	Spring force initial pressure F1 approx. N	Spring force final pressure F2 approx. N	Item No. screw-in washer
K0345.11903	K0345.12903	3	M6x0,75	M2	24	17	3,5	3,5	-/10	0,8	4,5	10	K0344.99
K0345.11004	K0345.12004	4	M8x1	M3	32	21	7	4	-/13	1	6	12	K0344.90
K0345.11105	K0345.12105	5	M10x1	M4	37	24	8	5	-/17	1,3	5	12	K0344.91
K0345.11206	K0345.12206	6	M12x1,5	M6	42	28	8	6	-/19	1,8	6	14	K0344.92
K0345.11308	K0345.12308	8	M16x1,5	M8	56	36	12	8	-/24	2,3	15	35	K0344.93
K0345.11410	K0345.12410	10	M20x1,5	M8	62	40	12	10	-/30	2,8	15	34	K0344.94
K0345.11412	K0345.12412	12	M20x1,5	M8	66	42	12	12	-/30	2,8	15	39	K0344.94
K0345.11516	K0345.12516	16	M24x2	M10	80	50	14	16	-/36	3,2	20	46	K0344.95

Cam Action Indexing Plungers



INCH Parts METRIC Parts

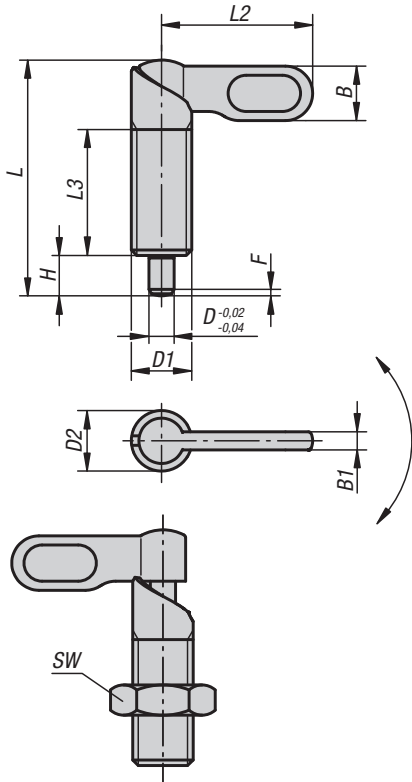

Style C
grip powder-coated
without nut

Style D
grip powder-coated
with nut



Material:
Steel quality class 5.8

Type:
Black oxide finish.
Pin hardened and ground.

Part Number Example:
K0348.0604A4

Note:
Cam-Action Indexing Plungers are used when the indexing pin should not project all the time. Turning the handle through 180° retracts the pin. A notch ensures that the handle remains in this position.

KIPP Cam Action Indexing Plungers, inch

Item No. Style C	Item No. Style D	D	D1	D2	L	L2	L3	B	B1	H	SW	F x 30°	Spring force initial pressure F1 approx. N	Spring force final pressure F2 approx. N
K0348.0604A4	K0348.0704A4	4	3/8-16	10	38	25	20	9	3	6	-1 9/16	1	8	14
K0348.0605A4	K0348.0705A4	5	3/8-16	10	38	25	20	9	3	6	-1 9/16	1,3	8	14
K0348.0606A4	K0348.0706A4	6	3/8-16	10	38	25	20	9	3	6	-1 9/16	1,8	8	14
K0348.0604AL	K0348.0704AL	4	3/8-24	10	38	25	20	9	3	6	-1 9/16	1	8	14
K0348.0605AL	K0348.0705AL	5	3/8-24	10	38	25	20	9	3	6	-1 9/16	1,3	8	14
K0348.0606AL	K0348.0706AL	6	3/8-24	10	38	25	20	9	3	6	-1 9/16	1,8	8	14
K0348.0605A5	K0348.0705A5	5	1/2-13	12	46,8	30	25	10,8	3,6	8	-1 3/4	1,3	8	15
K0348.0606A5	K0348.0706A5	6	1/2-13	12	46,8	30	25	10,8	3,6	8	-1 3/4	1,8	8	15
K0348.0608A5	K0348.0708A5	8	1/2-13	12	46,8	30	25	10,8	3,6	8	-1 3/4	2,3	8	15
K0348.0605AM	K0348.0705AM	5	1/2-20	12	46,8	30	25	10,8	3,6	8	-1 3/4	1,3	8	15
K0348.0606AM	K0348.0706AM	6	1/2-20	12	46,8	30	25	10,8	3,6	8	-1 3/4	1,8	8	15
K0348.0608AM	K0348.0708AM	8	1/2-20	12	46,8	30	25	10,8	3,6	8	-1 3/4	2,3	8	15
K0348.0606A6	K0348.0706A6	6	5/8-11	16	60,4	40	32	14,4	4,8	10	-1 15/16	1,8	15	35
K0348.0608A6	K0348.0708A6	8	5/8-11	16	60,4	40	32	14,4	4,8	10	-1 15/16	2,3	15	35
K0348.0610A6	K0348.0710A6	10	5/8-11	16	60,4	40	32	14,4	4,8	10	-1 15/16	2,8	15	35
K0348.0606AN	K0348.0706AN	6	5/8-28	16	60,4	40	32	14,4	4,8	10	-1 15/16	1,8	15	35
K0348.0608AN	K0348.0708AN	8	5/8-28	16	60,4	40	32	14,4	4,8	10	-1 15/16	2,3	15	35
K0348.0610AN	K0348.0710AN	10	5/8-28	16	60,4	40	32	14,4	4,8	10	-1 1-1/8	2,8	15	35
K0348.0608A7	K0348.0708A7	8	3/4-10	20	70	50	35	18	6	12	-1 1-1/8	2,3	20	60
K0348.0610A7	K0348.0710A7	10	3/4-10	20	70	50	35	18	6	12	-1 1-1/8	2,8	20	60
K0348.0612A7	K0348.0712A7	12	3/4-10	20	70	50	35	18	6	12	-1 1-1/8	3	20	60
K0348.0608A0	K0348.0708A0	8	3/4-16	20	70	50	35	18	6	12	-1 1-1/8	2,3	20	60
K0348.0610A0	K0348.0710A0	10	3/4-16	20	70	50	35	18	6	12	-1 1-1/8	2,8	20	60
K0348.0612A0	K0348.0712A0	12	3/4-16	20	70	50	35	18	6	12	-1 1-1/8	3	20	60

Cam Action Indexing Plungers



KIPP Cam Action Indexing Plungers, metric

Item No. Style C	Item No. Style D	D	D1	D2	L	L2	L3	B	B1	H	SW	F x 30°	Spring force initial pressure F1 approx. N	Spring force final pressure F2 approx. N
K0348.060410	K0348.070410	4	M10	10	38	25	20	9	3	6	-/17	1	8	14
K0348.060510	K0348.070510	5	M10	10	38	25	20	9	3	6	-/17	1,3	8	14
K0348.060610	K0348.070610	6	M10	10	38	25	20	9	3	6	-/17	1,8	8	14
K0348.0604101	K0348.0704101	4	M10x1	10	38	25	20	9	3	6	-/17	1	8	14
K0348.0605101	K0348.0705101	5	M10x1	10	38	25	20	9	3	6	-/17	1,3	8	14
K0348.0606101	K0348.0706101	6	M10x1	10	38	25	20	9	3	6	-/17	1,8	8	14
K0348.060512	K0348.070512	5	M12	12	46,8	30	25	10,8	3,6	8	-/19	1,3	8	15
K0348.060612	K0348.070612	6	M12	12	46,8	30	25	10,8	3,6	8	-/19	1,8	8	15
K0348.060812	K0348.070812	8	M12	12	46,8	30	25	10,8	3,6	8	-/19	2,3	8	15
K0348.0605121	K0348.0705121	5	M12x1,5	12	46,8	30	25	10,8	3,6	8	-/19	1,3	8	15
K0348.0606121	K0348.0706121	6	M12x1,5	12	46,8	30	25	10,8	3,6	8	-/19	1,8	8	15
K0348.0608121	K0348.0708121	8	M12x1,5	12	46,8	30	25	10,8	3,6	8	-/19	2,3	8	15
K0348.060616	K0348.070616	6	M16	16	60,4	40	32	14,4	4,8	10	-/24	1,8	15	35
K0348.060816	K0348.070816	8	M16	16	60,4	40	32	14,4	4,8	10	-/24	2,3	15	35
K0348.061016	K0348.071016	10	M16	16	60,4	40	32	14,4	4,8	10	-/24	2,8	15	35
K0348.0606161	K0348.0706161	6	M16x1,5	16	60,4	40	32	14,4	4,8	10	-/24	1,8	15	35
K0348.0608161	K0348.0708161	8	M16x1,5	16	60,4	40	32	14,4	4,8	10	-/24	2,3	15	35
K0348.0610161	K0348.0710161	10	M16x1,5	16	60,4	40	32	14,4	4,8	10	-/24	2,8	15	35
K0348.060820	K0348.070820	8	M20	20	70	50	35	18	6	12	-/30	2,3	20	60
K0348.061020	K0348.071020	10	M20	20	70	50	35	18	6	12	-/30	2,8	20	60
K0348.061220	K0348.071220	12	M20	20	70	50	35	18	6	12	-/30	3	20	60
K0348.0608201	K0348.0708201	8	M20x1,5	20	70	50	35	18	6	12	-/30	2,3	20	60
K0348.0610201	K0348.0710201	10	M20x1,5	20	70	50	35	18	6	12	-/30	2,8	20	60
K0348.0612201	K0348.0712201	12	M20x1,5	20	70	50	35	18	6	12	-/30	3	20	60

Cam Action Indexing Plungers

stainless steel

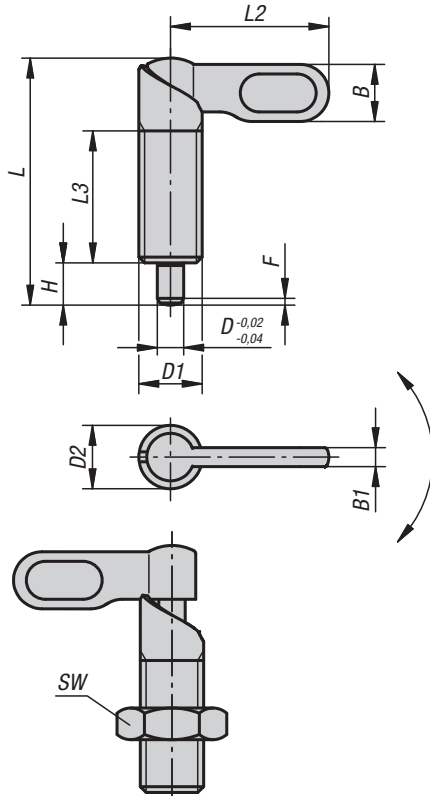

Style A
grip uncoated
without nut

Style B
grip uncoated
with nut



Material:
Stainless steel 1.4305.

Type:
Natural finish; pin ground, not hardened

Part Number Example:
K0637.10404A4

Note:
Cam Action Indexing Plungers are used when the locking pin should not project at certain times. Turning the bolt through 180° retracts the pin. A locking notch ensures that the cam action indexing plunger is held in this position.

KIPP Cam Action Indexing Plungers in stainless steel, inch

Item No. Style A	Item No. Style B	D	D1	D2	L	L2	L3	B	B1	H	SW	F x 30°	Spring force initial pressure F1 approx. N	Spring force final pressure F2 approx. N
K0637.10404A4	K0637.10504A4	4	3/8-16	10	38	25	20	9	3	6	-1 9/16	1	8	14
K0637.10405A4	K0637.10505A4	5	3/8-16	10	38	25	20	9	3	6	-1 9/16	1,3	8	14
K0637.10406A4	K0637.10506A4	6	3/8-16	10	38	25	20	9	3	6	-1 9/16	1,8	8	14
K0637.10404AL	K0637.10504AL	4	3/8-24	10	38	25	20	9	3	6	-1 9/16	1	8	14
K0637.10405AL	K0637.10505AL	5	3/8-24	10	38	25	20	9	3	6	-1 9/16	1,3	8	14
K0637.10406AL	K0637.10506AL	6	3/8-24	10	38	25	20	9	3	6	-1 9/16	1,8	8	14
K0637.10405A5	K0637.10505A5	5	1/2-13	12	46,8	30	25	10,8	3,6	8	-1 3/4	1,3	8	15
K0637.10406A5	K0637.10506A5	6	1/2-13	12	46,8	30	25	10,8	3,6	8	-1 3/4	1,8	8	15
K0637.10408A5	K0637.10508A5	8	1/2-13	12	46,8	30	25	10,8	3,6	8	-1 3/4	2,3	8	15
K0637.10405AM	K0637.10505AM	5	1/2-20	12	46,8	30	25	10,8	3,6	8	-1 3/4	1,3	8	15
K0637.10406AM	K0637.10506AM	6	1/2-20	12	46,8	30	25	10,8	3,6	8	-1 3/4	1,8	8	15
K0637.10408AM	K0637.10508AM	8	1/2-20	12	46,8	30	25	10,8	3,6	8	-1 3/4	2,3	8	15
K0637.10406A6	K0637.10506A6	6	5/8-11	16	60,4	40	32	14,4	4,8	10	-1 15/16	1,8	15	35
K0637.10408A6	K0637.10508A6	8	5/8-11	16	60,4	40	32	14,4	4,8	10	-1 15/16	2,3	15	35
K0637.10410A6	K0637.10510A6	10	5/8-11	16	60,4	40	32	14,4	4,8	10	-1 15/16	2,8	15	35
K0637.10406AN	K0637.10506AN	6	5/8-28	16	60,4	40	32	14,4	4,8	10	-1 15/16	1,8	15	35
K0637.10408AN	K0637.10508AN	8	5/8-28	16	60,4	40	32	14,4	4,8	10	-1 15/16	2,3	15	35
K0637.10410AN	K0637.10510AN	10	5/8-28	16	60,4	40	32	14,4	4,8	10	-1 15/16	2,8	15	35
K0637.10408A7	K0637.10508A7	8	3/4-10	20	70	50	35	18	6	12	-1 1-1/8	2,3	20	60
K0637.10410A7	K0637.10510A7	10	3/4-10	20	70	50	35	18	6	12	-1 1-1/8	2,8	20	60
K0637.10412A7	K0637.10512A7	12	3/4-10	20	70	50	35	18	6	12	-1 1-1/8	3	20	60
K0637.10408A0	K0637.10508A0	8	3/4-16	20	70	50	35	18	6	12	-1 1-1/8	2,3	20	60
K0637.10410A0	K0637.10510A0	10	3/4-16	20	70	50	35	18	6	12	-1 1-1/8	2,8	20	60
K0637.10412A0	K0637.10512A0	12	3/4-16	20	70	50	35	18	6	12	-1 1-1/8	3	20	60

Cam Action Indexing Plungers

stainless steel



KIPP Cam Action Indexing Plungers in stainless steel, metric

Item No. Style A	Item No. Style B	D	D1	D2	L	L2	L3	B	B1	H	SW	F x 30°	Spring force initial pressure F1 approx. N	Spring force final pressure F2 approx. N
K0637.1040410	K0637.1050410	4	M10	10	38	25	20	9	3	6	-/17	1	8	14
K0637.1040510	K0637.1050510	5	M10	10	38	25	20	9	3	6	-/17	1,3	8	14
K0637.1040610	K0637.1050610	6	M10	10	38	25	20	9	3	6	-/17	1,8	8	14
K0637.10404101	K0637.10504101	4	M10x1	10	38	25	20	9	3	6	-/17	1	8	14
K0637.10405101	K0637.10505101	5	M10x1	10	38	25	20	9	3	6	-/17	1,3	8	14
K0637.10406101	K0637.10506101	6	M10x1	10	38	25	20	9	3	6	-/17	1,8	8	14
K0637.1040512	K0637.1050512	5	M12	12	46,8	30	25	10,8	3,6	8	-/19	1,3	8	15
K0637.1040612	K0637.1050612	6	M12	12	46,8	30	25	10,8	3,6	8	-/19	1,8	8	15
K0637.1040812	K0637.1050812	8	M12	12	46,8	30	25	10,8	3,6	8	-/19	2,3	8	15
K0637.10405121	K0637.10505121	5	M12x1,5	12	46,8	30	25	10,8	3,6	8	-/19	1,3	8	15
K0637.10406121	K0637.10506121	6	M12x1,5	12	46,8	30	25	10,8	3,6	8	-/19	1,8	8	15
K0637.10408121	K0637.10508121	8	M12x1,5	12	46,8	30	25	10,8	3,6	8	-/19	2,3	8	15
K0637.1040616	K0637.1050616	6	M16	16	60,4	40	32	14,4	4,8	10	-/24	1,8	15	35
K0637.1040816	K0637.1050816	8	M16	16	60,4	40	32	14,4	4,8	10	-/24	2,3	15	35
K0637.1041016	K0637.1051016	10	M16	16	60,4	40	32	14,4	4,8	10	-/24	2,8	15	35
K0637.10406161	K0637.10506161	6	M16x1,5	16	60,4	40	32	14,4	4,8	10	-/24	1,8	15	35
K0637.10408161	K0637.10508161	8	M16x1,5	16	60,4	40	32	14,4	4,8	10	-/24	2,3	15	35
K0637.10410161	K0637.10510161	10	M16x1,5	16	60,4	40	32	14,4	4,8	10	-/24	2,8	15	35
K0637.1040820	K0637.1050820	8	M20	20	70	50	35	18	6	12	-/30	2,3	20	60
K0637.1041020	K0637.1051020	10	M20	20	70	50	35	18	6	12	-/30	2,8	20	60
K0637.1041220	K0637.1051220	12	M20	20	70	50	35	18	6	12	-/30	3	20	60
K0637.10408201	K0637.10508201	8	M20x1,5	20	70	50	35	18	6	12	-/30	2,3	20	60
K0637.10410201	K0637.10510201	10	M20x1,5	20	70	50	35	18	6	12	-/30	2,8	20	60
K0637.10412201	K0637.10512201	12	M20x1,5	20	70	50	35	18	6	12	-/30	3	20	60

Mounting brackets

aluminum

METRIC
Parts

New Item

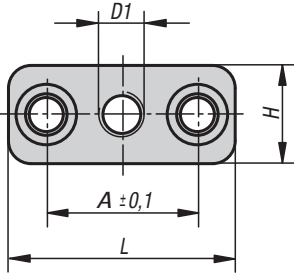

Style A
Fastening hole
parallel to thread

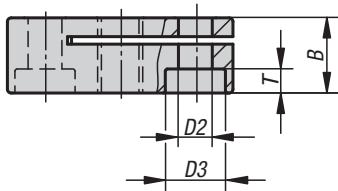

Material:
Aluminum 3.2163

Type:
Black anodized

Part Number Example:
K0638.308

Note:
Mounting brackets are an assembly aid for
cam-action and other indexing plungers and expand
the application field. For use with socket head screws
DIN 912 / ISO 4762.

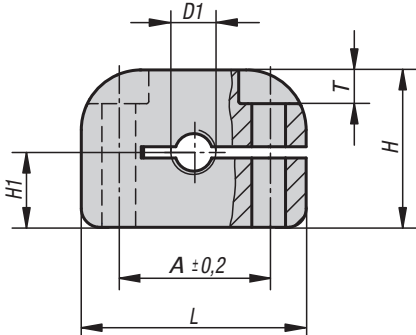

Style B
Fastening hole
perpendicular to thread

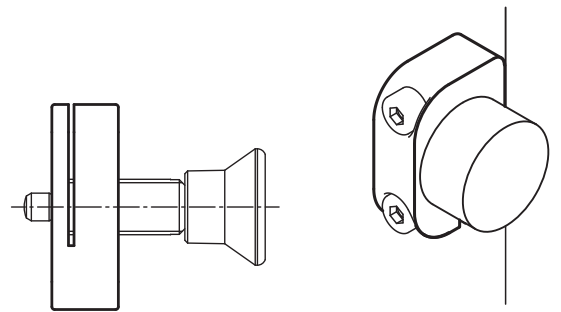
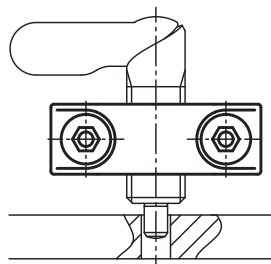
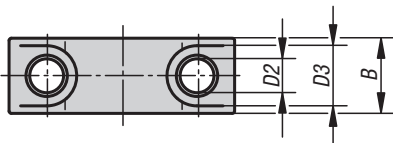

Mounting brackets

aluminum



KIPP Mounting brackets aluminum, metric

Item No.	Style	D1	D2	D3	A	B	H	H1	L	T
K0638.306	A	M6	4,5	8	20	10	13	-	30	3,2
K0638.3061	A	M6x0,75	4,5	8	20	10	13	-	30	3,2
K0638.308	A	M8	4,5	8	20	10	13	-	30	3,2
K0638.3081	A	M8x1	4,5	8	20	10	13	-	30	3,2
K0638.310	A	M10	5,5	10	24	12	18	-	37	3,9
K0638.3101	A	M10x1	5,5	10	24	12	18	-	37	3,9
K0638.312	A	M12	5,5	10	24	12	18	-	37	3,9
K0638.3121	A	M12x1,5	5,5	10	24	12	18	-	37	3,9
K0638.316	A	M16	5,5	10	32	15	25	-	46	3,9
K0638.3161	A	M16x1,5	5,5	10	32	15	25	-	46	3,9
K0638.320	A	M20	5,5	10	32	15	25	-	46	3,9
K0638.3201	A	M20x1,5	5,5	10	32	15	25	-	46	3,9
K0638.406	B	M6	4,5	8	20	10	21	10	30	4,5
K0638.4061	B	M6x0,75	4,5	8	20	10	21	10	30	4,5
K0638.408	B	M8	4,5	8	20	10	21	10	30	4,5
K0638.4081	B	M8x1	4,5	8	20	10	21	10	30	4,5
K0638.410	B	M10	5,5	10	24	12	26	13	36	5,5
K0638.4101	B	M10x1	5,5	10	24	12	26	13	36	5,5
K0638.412	B	M12	5,5	10	24	12	26	13	36	5,5
K0638.4121	B	M12x1,5	5,5	10	24	12	26	13	36	5,5
K0638.416	B	M16	5,5	10	32	15	29	17	46	5,5
K0638.4161	B	M16x1,5	5,5	10	32	15	29	17	46	5,5
K0638.420	B	M20	5,5	10	32	15	29	17	46	5,5
K0638.4201	B	M20x1,5	5,5	10	32	15	29	17	46	5,5

Mounting brackets

METRIC
Parts

New Item

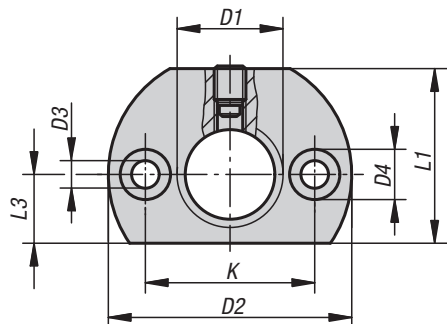

Style A
fastening hole parallel
to indexing plunger

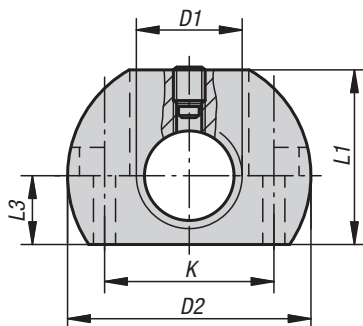
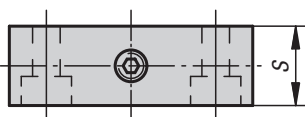

Style B
fastening hole perpendicular
to indexing plunger

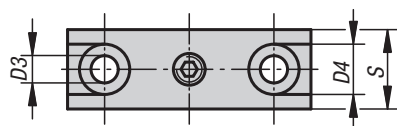

Material:

Steel.

Type:

Black oxide finish.

Part Number Example:

K0638.116

Note:

Mounting brackets are assembly aids for cam-action indexing plungers and extend their application field. They can also be used for other indexing plungers.

KIPP Mounting brackets, metric

Item No.	Style	D1	D2	D3	D4	K	L1	L3	S
K0638.112	A	M12	36	5,5	10	24	25	10	12
K0638.1121	A	M12x1,5	36	5,5	10	24	25	10	12
K0638.116	A	M16	46	5,5	10	32	33	13	15
K0638.1161	A	M16x1,5	46	5,5	10	32	33	13	15
K0638.120	A	M20	46	5,5	10	32	33	13	15
K0638.1201	A	M20x1,5	46	5,5	10	32	33	13	15
K0638.212	B	M12	36	5,5	10	24	25	10	12
K0638.2121	B	M12x1,5	36	5,5	10	24	25	10	12
K0638.216	B	M16	46	5,5	10	32	33	13	15
K0638.2161	B	M16x1,5	46	5,5	10	32	33	13	15
K0638.220	B	M20	46	5,5	10	32	33	13	15
K0638.2201	B	M20x1,5	46	5,5	10	32	33	13	15

Assembly and Installation Instructions for Precision Indexing Plungers



**Precision Indexing Plungers
with tapered pin**

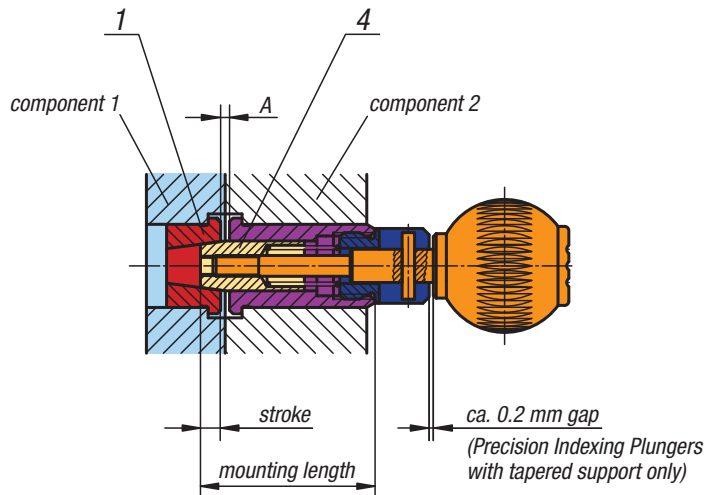

**Precision Indexing Plungers
with cylindrical pin**

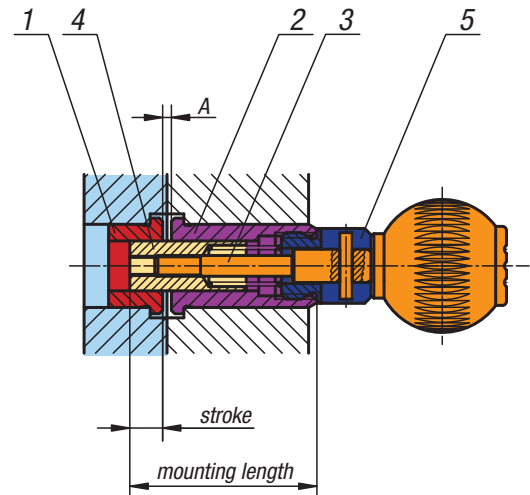

Assembly Instructions:

1. Fit tapered or cylindrical bushing (No. 1) into component 1.
2. Fit bushing (No. 2) into component 2.
3. Determine the mounting length (actual dimension). Mounting length = A + stroke + length of No. 2. Note the graticule of 0.2 mm with models with tapered support.
4. Glue threaded bolt (No. 3) and centering pin (No. 4) together grease-free with anaerobic adhesive. We recommend Loctite 638.
5. Screw centering pin with nut (No. 4) and handle into the mounted bushing (No. 2). If necessary glue together grease-free with anaerobic adhesive.
6. Check whether the product is operational. Adhere to the release stroke in the catalog with locking device versions.

Note:

The Precision Indexing Plunger is only ready for operation after the stated adhesive hardening time. When gluing the components, ensure that no adhesive enters into contact with movable parts.



Precision Indexing Plungers

with tapered pins



METRIC
Parts

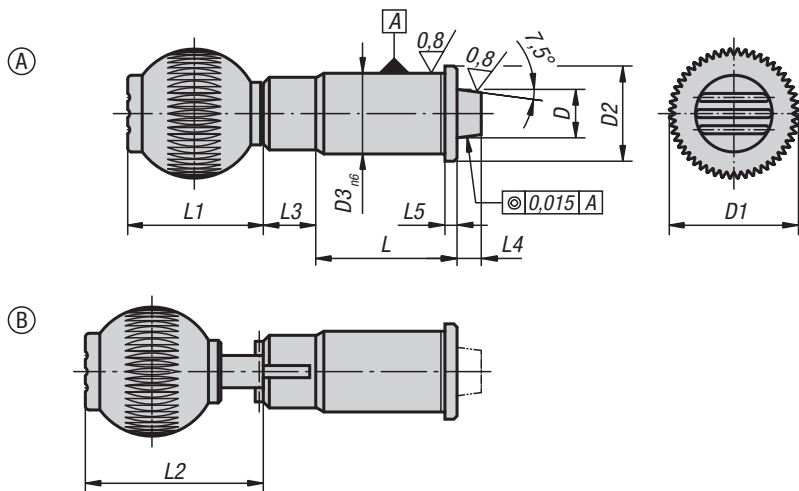

Material:

Steel, grip ball thermoplastic

Type:

Hardened and ground, grip ball black gray

Part Number Example:

K0359.010

Note:

The Indexing Plungers with bushings are a perfect combination for rapid positioning and fixing. The precise design of both the Indexing Plunger and the bushing guarantees high repeating accuracy when assembling two elements.

Technical information see assembly and installation instructions.

Drawing reference:

Style A: standard version

Style B: locking version

KIPP Precision indexing plungers with tapered pins, metric

Item No. Style A Standard	Item No. Style B lockable	D	D1	D2	D3	L	L1	L2	L3	L4 min.	L5	Spring force initial pressure F1 approx. N	Spring force final pressure F2 approx. N	Internal thread Grip Ball
K0359.010	K0359.110	10	25	19	16	31	25	-/32,5	13	6	2,5	19	29	M6
K0359.012	K0359.112	12	32	23	20	35	33	-/40,5	13	6	3	22	35	M8
K0359.016	K0359.116	16	40	28	25	42	41,5	-/49	13	6	3	30	50	M10
K0359.020	K0359.120	20	40	33	30	50	41,5	-/49	13	6	3	46	63	M10
K0359.025	K0359.125	25	50	42	38	60	51	-/58,5	13	6	3	39	73	M10

Tapered Bushings

METRIC
Parts

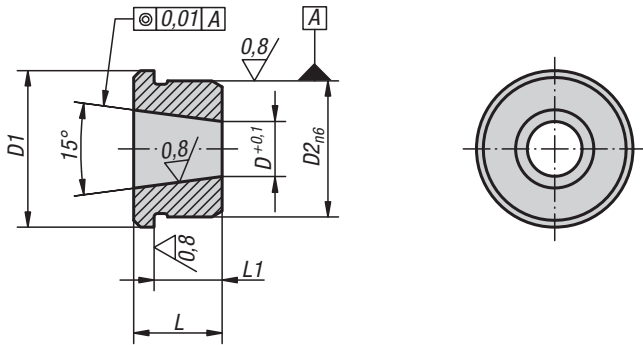

Material:
Steel.

Type:
Hardened and ground

Part Number Example:
K0360.10

Note:
Bushings for Precision Indexing Plungers K0359.

KIPP Tapered Bushings, metric

Item No.	D	D1	D2	L	L1
K0360.10	7,1	19	16	11	8,5
K0360.12	8,28	23	20	13	10
K0360.16	11,52	28	25	17	14
K0360.20	15,49	33	30	16	13
K0360.25	19,7	42	38	19	16

Precision Indexing Plungers

with cylindrical pins



METRIC
Parts

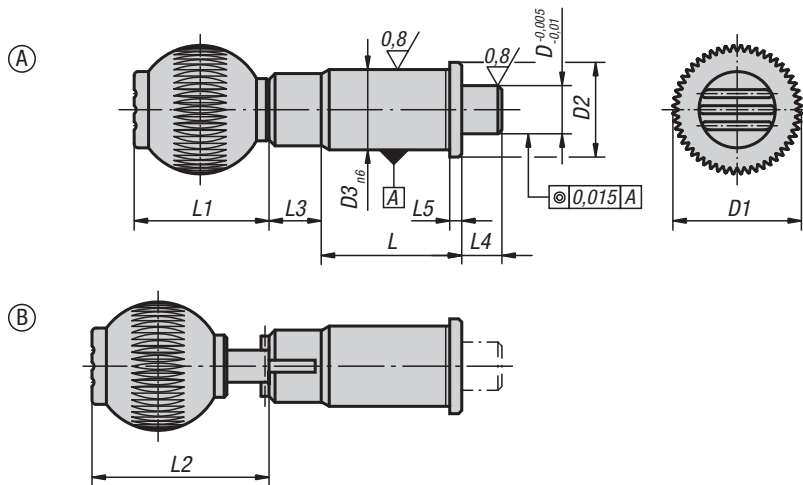

Material:

Steel, grip ball thermoplastic

Type:

Hardened and ground, grip ball black gray

Part Number Example:

K0361.010

Note:

The Indexing Plungers with bushings are a perfect combination for rapid positioning and fixing. The precise design of both the Indexing Plungers and the bushing guarantees high repeating accuracy when assembling two elements.

Technical Information see assembly and installation instructions.

Drawing reference:

Style A: standard version

Style B: locking version

KIPP Precision Indexing Plungers with cylindrical pins, metric

Item No. Style A Standard	Item No. Style B lockable	D	D1	D2	D3	L	L1	L2	L3	L4	L5	Spring force initial pressure F1 approx. N	Spring force final pressure F2 approx. N	Internal thread Grip Ball
K0361.010	K0361.110	10	25	19	16	31	25	-/36,5	13	10	2,5	15	30	M6
K0361.012	K0361.112	12	32	23	20	35	33	-/44,5	13	10	3	15	35	M8
K0361.016	K0361.116	16	40	28	25	42	41,5	-/53	13	10	3	20	50	M10
K0361.020	K0361.120	20	40	33	30	50	41,5	-/53	13	10	3	36	63	M10
K0361.025	K0361.125	25	50	42	38	60	51	-/62,5	13	10	3	20	73	M10

Cylindrical Bushings

METRIC
Parts

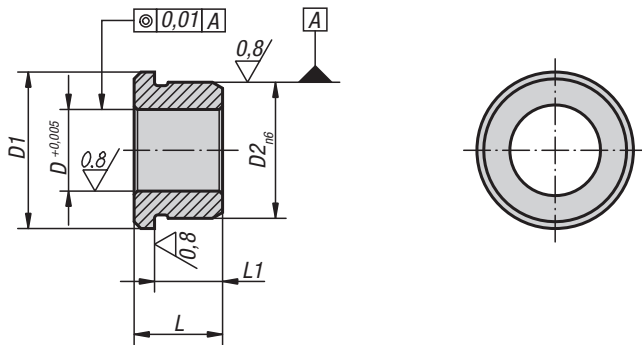

Material:
Steel.

Type:
Hardened and ground

Part Number Example:
K0362.10

Note:
Bushings for Precision Indexing Plungers K0361.

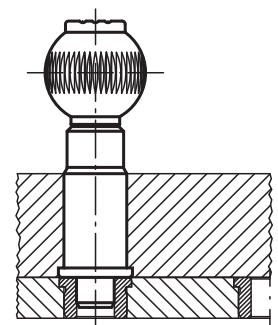

KIPP Cylindrical Bushings, metric

Item No.	D	D1	D2	L	L1
K0362.10	10	19	16	11	8,5
K0362.12	12	23	20	13	10
K0362.16	16	28	25	17	14
K0362.20	20	33	30	16	13
K0362.25	25	42	38	19	16

Grub Screws

with thrust point to DIN 6332

METRIC
Parts

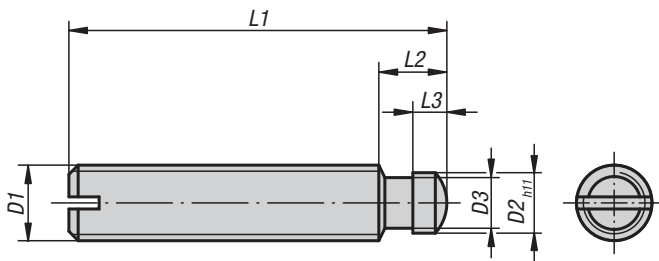

Material:
Steel or stainless steel

Type:
Steel: thrust point case-hardened, black.
Stainless steel: natural finish.

Part Number Example:
K0390.12X60
(include length L1)

Note:
The thrust journal of the Grub Screws to DIN 6332 is designed for direct clamping as well as for use in conjunction with a Thrust Pad K0392.

Drawing reference:
1) snap ring

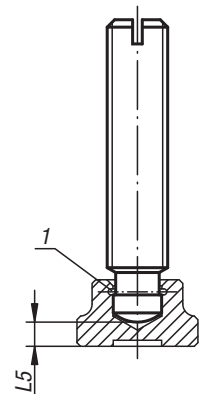

KIPP Grub Screws with thrust points to DIN 6332, metric

Item No. Steel	Item No. Stainless steel	D1	L1	D2	D3	L2	L3	L5
K0390.06X	K0390.061X	M6	30/35/40/50	4,5	4	6	2,5	2,2
K0390.08X	K0390.081X	M8	35/40/45/50/60	6	5,4	7,5	3	3
K0390.10X	K0390.101X	M10	50/55/60/65/80	8	7,2	9	4,5	3,6
K0390.12X	K0390.121X	M12	60/65/70/80/100	8	7,2	10	4,5	4,5
K0390.14X	K0390.141X	M14	60/80/100	10	9	12	5	5
K0390.16X	K0390.161X	M16	65/70/80/100/125	12	11	12	5	5,3
K0390.20X	K0390.201X	M20	80/90/100/125/150	15,5	14,4	14	5,5	5,6

Grub Screws

with ball thrust point

METRIC
Parts

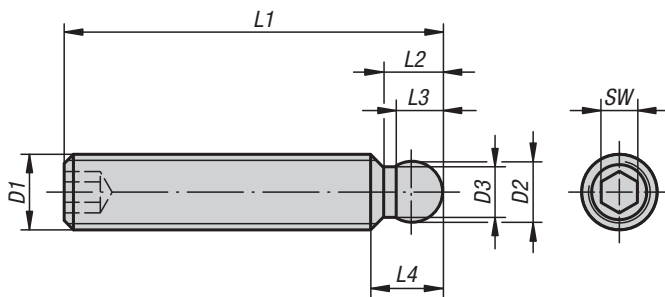

Material:

Quality class 5.8.

Type:

Black oxide finish.

Part Number Example:

K0391.06X50
(include length L1)

Note:

The Grub Screws are used in conjunction with a Thrust Pad K0393.

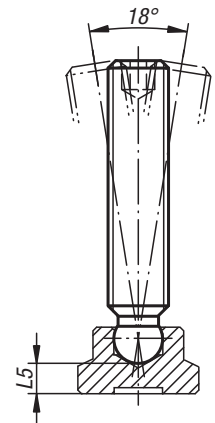

KIPP Grub Screws with ball thrust point, metric

Item No.	D1	L1	D2	D3	L2	L3	L4	L5	SW
K0391.06X	M6	30/35/40/50	4,5	3,5	4,3	3,7	5,5	3,8	3
K0391.08X	M8	35/40/45/50/60	6	4,8	5,8	4,8	7,4	4,4	4
K0391.10X	M10	50/55/60/65/80	8	6,5	7,2	6,3	9	5	5
K0391.12X	M12	60/65/70/80	8	6,5	7,2	6,3	9,8	6,9	6

Thrust Screws stainless steel

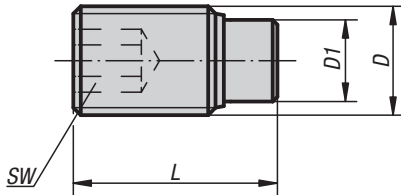

Material:

Screw stainless steel.
Bolts brass or POM.

Type:

Screw natural finish.

Part Number Example:

K0667.041X105 (include length L)

Note:

Thrust Screws are ideal for clamping or exerting pressure on threaded spindles, axles, shafts and treated surfaces without marring. Longer versions are specially designed to be glued in. They allow small to medium series of mechanical external thread fastening elements to be made cost-effectively.

KIPP Thrust Screws, stainless steel, metric

Item No.	Component material	D	D1	L	SW
K0667.041X	brass	M4	2,5	6,5/10,5/16,5/30,5/40,5	2
K0667.051X	brass	M5	3	8,5/12,5/20,5/30,5/40,5	2,5
K0667.061X	brass	M6	4	11,5/13,5/17,5/21,5/26,5/41,5/51,5/61,5	3
K0667.081X	brass	M8	5,5	12/22/32/52/62/82	4
K0667.101X	brass	M10	7	14/18/27/37	5
K0667.121X	brass	M12	8,5	22,5/32,5/42,5	6

Item No.	Component material	D	D1	L	SW
K0667.1041X	Polyacetal	M4	2	7/9/11/13/17/31/41	2
K0667.1051X	Polyacetal	M5	3	9/11/13/17/21/31/41	2,5
K0667.1061X	Polyacetal	M6	3,5	11,3/13,3/17,3/21,3/26,3/41,3/51,3/61,3	3
K0667.1081X	Polyacetal	M8	5	13,6/17,6/21,6/26,6/33,6/51,6/61,6/81,6	4
K0667.1101X	Polyacetal	M10	6,5	17,9/21,9/26,9/36,9	5
K0667.1121X	Polyacetal	M12	8	22,1/32,1/42,1	6

Thrust Pads

DIN 6311 extended

METRIC
Parts

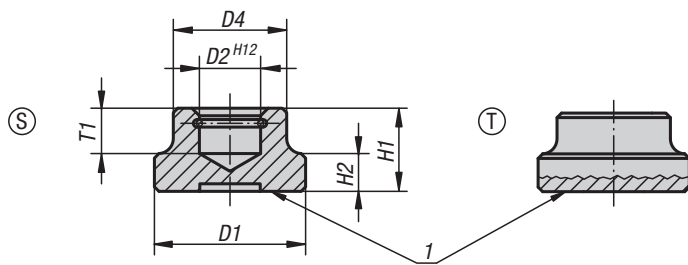

Material:

Steel case-hardened, snap ring in spring steel

Type:

Black oxide finish.

Part Number Example:

K0392.12

Note:

When fitting the Thrust Pad, ensure that it is inclined as far as possible in the direction of the snap ring opening. The snap ring is supplied assembled.

Drawing reference:

Style S: thrust pad with snap ring
Style T: low design, large clamping surface with snap ring

1) Pressure surface

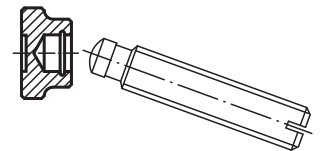

KIPP Thrust Pads DIN 6311 extended, metric

Item No.	Style	D1	D2	D4	H1	H2	T1	For grub screws with trust point DIN 6332
K0392.06	S	12	4,6	10	7	2,5	4	M6
K0392.08	S	16	6,1	12	9	4	5	M8
K0392.10	S	20	8,1	15	11	5	6	M10
K0392.12	S	25	8,1	18	13	7	7	M12
K0392.16	S	32	12,1	22	15	7	7,5	M16
K0392.20	S	40	15,6	28	16	9	8	M20
K0392.108	T	25	6,1	12	8	4	4,5	M8
K0392.110	T	32	8,1	18	10	6	6	M10 / M12
K0392.116	T	40	12,1	22	12	7	7	M16

Thrust Pads

METRIC
Parts

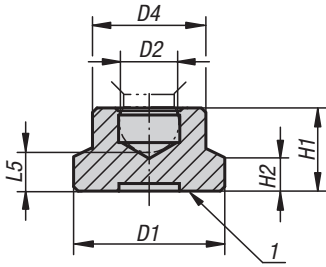

Material:
Steel.
PA 6 plastic.

Type:
Black oxide finish.
Black plastic.

Part Number Example:
K0393.08

Drawing reference:
1) thrust face



KIPP Thrust Pads, metric

Item No.	Style	Base material	D1	D2	D4	H1	H2	L5	Suitable for Grub Screws
K0393.06	A	Steel	15	4,4	8,6	7,6	2,5	3,8	M6
K0393.08	A	Steel	18	5,9	12	9	3,5	4,4	M8
K0393.10	A	Steel	21	7,9	15	11	4	5	M10
K0393.12	A	Steel	25	7,9	18	13	5	6,9	M12
K0393.206	A	Polyamide	15	4,4	8,6	7,6	2,5	3,8	M6
K0393.208	B	Polyamide	18	5,9	12	9	3,5	4,4	M8
K0393.210	C	Polyamide	21	7,9	15	11	4	5	M10
K0393.212	C	Polyamide	25	7,9	18	13	5	6,9	M12

Ball head position adjusters



METRIC
Parts

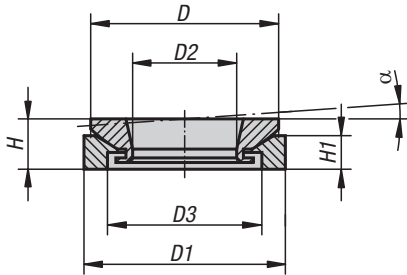

Material:

Steel 1.7225.
Stainless steel 1.4305.

Type:

Steel blue chromate.
Stainless steel natural finish.

Part Number Example:

K0691.151

Note:

The Ball head position adjuster allows exact positioning when assembling sloping bases up to approx. 4° angle of inclination. A further Ball head position adjuster is recommended as a base in sloped positions of $D3 > 1^\circ$ for evenly positioning the bolts. Top and bottom can not fall apart as they are secured.

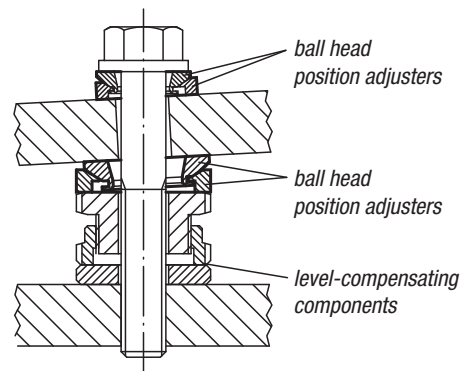

KIPP Ball head position adjusters, metric

Item No. Steel	Item No. Stainless steel	H	H1	D	D1	D2	D3	α
K0691.151	K0691.152	8	5,5	23	25	8,5	15	4°
K0691.201	K0691.202	10	6,2	30	32	13	20	4°
K0691.301	K0691.302	12,5	9	40	45	20	30	4°
K0691.401	K0691.402	16	13	52	58	29	38	4°
K0691.501	K0691.502	20	14	65	70	36	48	4°

Notes:

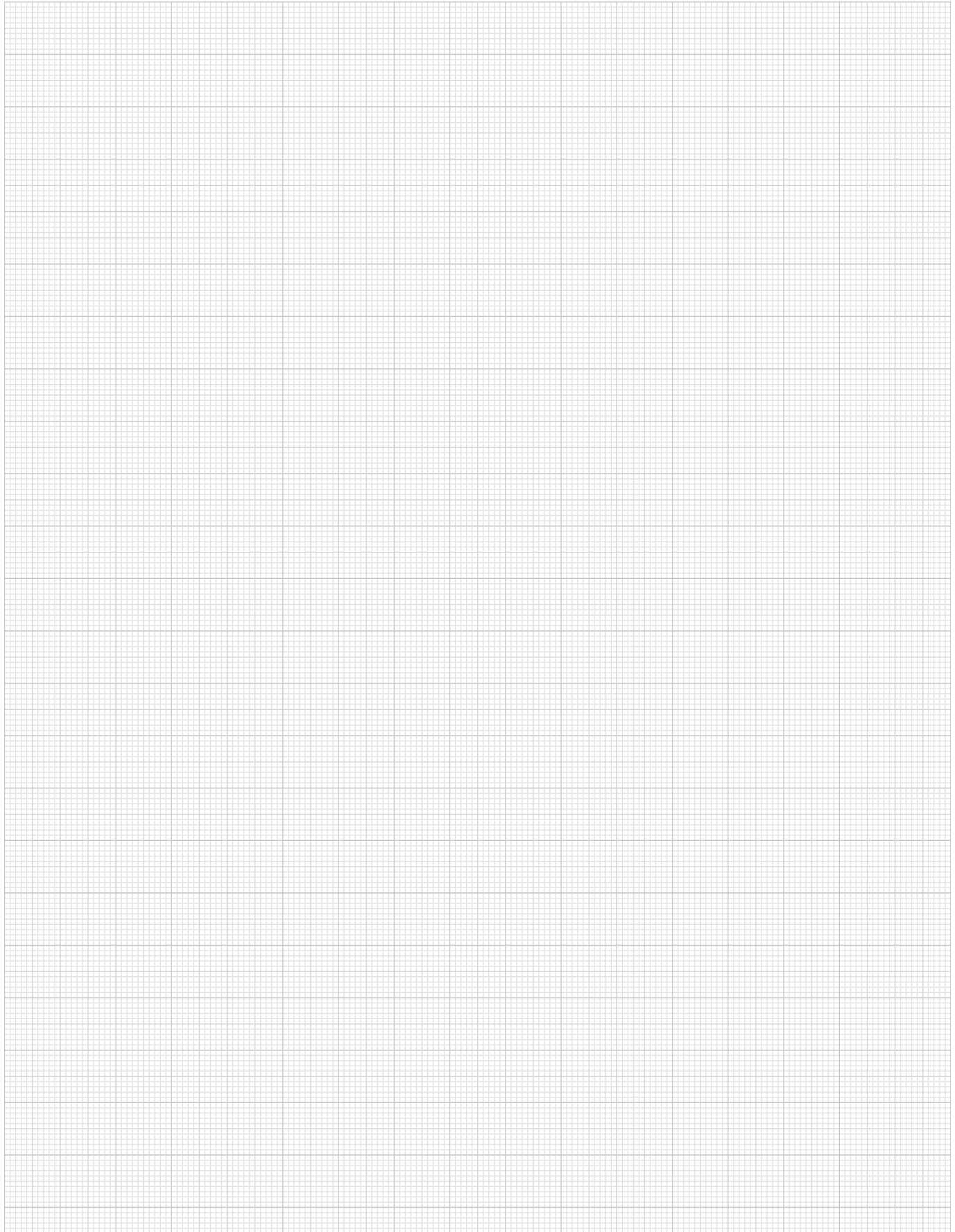

Reference Table - Conversion of Measurements



Pressure		
From	To	Conversion
psi	Kilopond/cm ² (kp/cm ²)	psi x 0.07031 = kp/cm ²
Kilopond/cm ² (kp/cm ²)	psi	kp/cm ² x 14.22 = psi
psi	Bar	psi x 0.07 = Bar
Bar	psi	Bar x 14.29 = psi

Linear Measure		
From	To	Conversion
Inch (in)	Millimeter (mm)	in x 25.4 = mm
Millimeter (mm)	Inch (in)	mm x 0.03937 = in
Inch	Millimeter (mm)	Inch x 25.4 = mm
Millimeter (mm)	Inch	mm x 0.03937 = Inch
Foot	Meter (m)	Foot x 0.3048 = m
Meter (m)	Foot	m x 3.281 = Foot
Yard	Meter (m)	Yard x 0.9144 = m
Meter (m)	Yard	m x 1.0936 = Yard
Miles (mils)	Kilometer (km)	mils x 1.609 = km
Kilometer (km)	Miles (mils)	km x 0.622 = mils

Forces		
From	To	Conversion
Pounds (lbs)	Newton (N)	lbs x 4.45 = N
Newton (N)	Pounds (lbs)	N x 0.225 = lbs
PS (horsepower)	Kilowatt (kW)	PS x 0.735 = kW
Kilowatt (kW)	PS (horsepower)	kW x 1.36 = PS

Weights		
From	To	Conversion
Pounds (lbs)	Kilopond/cm ² (kp/cm ²)	lbs x 0.45 = kp/cm ²
Kilopond/cm ² (kp/cm ²)	Pounds (lbs)	kp/cm ² x 2.2 = lbs
Ounces (oz)	Gramm (g)	oz x 28 = g
Gramm (g)	Ounces (oz)	g x 0.035 = oz
Pounds (lbs)	Kilogramm (kg)	lbs x 0.4536 = kg
Kilogramm (kg)	Pounds (lbs)	kg x 2.205 = lbs

Torque		
From	To	Conversion
Foot-pounds (ft-lbs)	Newton-Meter (Nm)	ft/lbs x 1.35 = Nm
Newton-Meter (Nm)	Foot-pounds (ft-lbs)	Nm x 0.74 = ft/lbs
Newton-Meter (Nm)	Kilopond/cm (kp/cm)	Nm x 0.102 = kp/cm

General Information about:

KIPP Clamping Tools

KIPP Operating Parts

Novo-Grip

Sympa Touch

KIPP Machine and Jig Devices



Materials:

POM = Polyoxymethylene - Delrin®

Deviating from the standard design, other materials and quality classes are available on request.

Surface finishes:

Other surface finishes are available at additional cost, e.g. matte-finished or high-polish chromium-plated steel parts.

Other colors are also available on request for plastic coatings or molded plastic parts.

Threads:

Threads are manufactured to ISO DIN 13 medium tolerance class, i.e. 6H for nut threads and 6g for bolt threads. External threads up to 60 mm are generally supplied fully threaded. Screw lengths of 70 mm and more are supplied with 60 mm long threads.

Threads of aluminum grips:

Especially threads of aluminum grips cannot be true to gauge size due to final surface finish refinement and the removal of material during related pretreatment.

The majority of these threads are moulded in order to strengthen the material. As a result, the tearing resistance of aluminum for a thread with M5x10 is higher than 2000 N.

Special versions:

KIPP Clamp and Tension Levers can also be supplied on request with predrilled inserts, locating holes, locating bolts for pinning and other thread ends to DIN 78 (except for flat point) and to DIN 6332.

As a basic rule, you can rely on us as a competent partner for your daily clamping needs. We are always happy to advise you.

Thread Pitch Chart:

Metric Coarse Thread:

M3 X 0.5
M4 X 0.7
M5 X 0.8
M6 X 1.0
M8 X 1.25
M10 X 1.5
M12 X 1.75
M14 X 2.00
M16 X 2.00
M18 X 2.50
M20 X 2.50
M22 X 2.50
M24 X 3.00

Metric Fine Thread:

M3 X 0.35
M4 X 0.50
M5 X 0.50
M6 X 0.75
M8 X 1.00
M10 X 1.25
M12 X 1.50
M14 X 1.50
M16 X 1.50
M18 X 1.5
M20 X 1.5
M24 X 1.5
M24 X 2.0

Conversion Chart:

10mm = .39"
12mm = .47"
15mm = .59"
20mm = .79"
25mm = .98"
30mm = 1.18"
25mm = 1.38"
40mm = 1.57"
45mm = 1.77"
50mm = 1.97"
55mm = 2.17"
60mm = 2.36"
70mm = 2.76"
80mm = 3.15"
90mm = 3.54"

General Terms and Conditions



Kipp Inc. ("Kipp") is pleased to present its products to industry. All products are sold under our standard terms and conditions of sale, which include an express warranty, warranty disclaimers, and limitations of remedies and responsibilities. Kipp reserves the right to delete products and to make improvements, changes or modifications to all products manufactured or sold by Kipp, without incurring any liability to incorporate these changes in any part or component - past, present or future. Any specifications, guidelines, technical data and other information provided herein supersede all previous similar information published by Kipp unless specifically provided in writing by Kipp pursuant to a specific inquiry. All information provided by Kipp, regardless of nature or form, is prepared in good faith based upon our experience, mathematical models, and/or scientific models as general information only. Any suggestion or projections offered in writing, by phone, in person, or in any other form are provided in good faith, but since the functionality and reliability of Kipp products can vary with the application and with the equipment and other components with which it is used, and user skills, all warranties (other than the Kipp non-assignable standard express written warranty given to direct purchasers from Kipp), such as any implied warranty or merchantability or fitness for a particular purpose, are disclaimed.

Kipp products are generally sold through distributors and Kipp disclaims all warranties to indirect purchasers of Kipp product. Purchasers should contact their sellers with any claims related to Kipp products. Kipp is not responsible in contract, tort, or otherwise for any inaccuracies or for any direct, incidental or consequential damages resulting therefrom or from the purchase, use, storage or sale of Kipp products. Any suggestion or projection should be fully analyzed and/or tested by the customer before selecting any Kipp product or taking any action based thereon. Kipp products are often used in specialized complex applications. Post delivery field engineering and changes may be required by users to obtain the best results possible in any particular application. Please call our Engineering Department or Sales Department at (866) 547-7166 if you have further questions. All information furnished is subject to the foregoing disclaimers and limitations.

The publication of this catalog renders all earlier publications invalid. Dimensions and other information is correct at the time of printing.

We reserve the right to make technical changes. We also cannot be held liable for printing errors that may occur in this publication.

Reprint and reproduction, even excerpts, are only allowed with KIPP Inc. permission.

KIPP Inc.

Copyright KIPP Inc.

WE01USCAT1707